



Z1000SX
Z1000SX ABS
Ninja 1000
Ninja 1000 ABS



Motorcycle Service Manual

Quick Reference Guide

General Information	1
Periodic Maintenance	2
Fuel System (DFI)	3
Cooling System	4
Engine Top End	5
Clutch	6
Engine Lubrication System	7
Engine Removal/Installation	8
Crankshaft/Transmission	9
Wheels/Tires	10
Final Drive	11
Brakes	12
Suspension	13
Steering	14
Frame	15
Electrical System	16
Appendix	17

This quick reference guide will assist you in locating a desired topic or procedure.

- Bend the pages back to match the black tab of the desired chapter number with the black tab on the edge at each table of contents page.
- Refer to the sectional table of contents for the exact pages to locate the specific topic required.

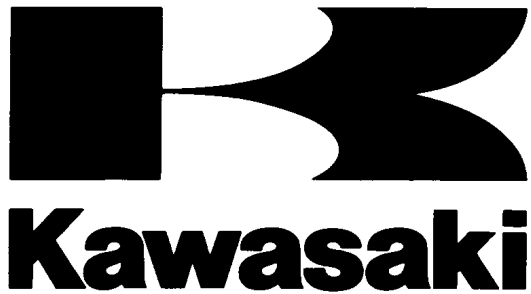

Z1000SX
Z1000SX ABS
Ninja 1000
Ninja 1000 ABS

Motorcycle Service Manual

All rights reserved. No parts of this publication may be reproduced, stored in a retrieval system, or transmitted in any form or by any means, electronic mechanical photocopying, recording or otherwise, without the prior written permission of Quality Assurance Division/Motorcycle & Engine Company/Kawasaki Heavy Industries, Ltd., Japan.

No liability can be accepted for any inaccuracies or omissions in this publication, although every possible care has been taken to make it as complete and accurate as possible.

The right is reserved to make changes at any time without prior notice and without incurring an obligation to make such changes to products manufactured previously. See your Motorcycle dealer for the latest information on product improvements incorporated after this publication.

All information contained in this publication is based on the latest product information available at the time of publication. Illustrations and photographs in this publication are intended for reference use only and may not depict actual model component parts.

LIST OF ABBREVIATIONS

A	ampere(s)	lb	pound(s)
ABDC	after bottom dead center	m	meter(s)
AC	alternating current	min	minute(s)
ATDC	after top dead center	N	newton(s)
BBDC	before bottom dead center	Pa	pascal(s)
BDC	bottom dead center	PS	horsepower
BTDC	before top dead center	psi	pound(s) per square inch
°C	degree(s) Celsius	r	revolution
DC	direct current	rpm	revolution(s) per minute
F	farad(s)	TDC	top dead center
°F	degree(s) Fahrenheit	TIR	total indicator reading
ft	foot, feet	V	volt(s)
g	gram(s)	W	watt(s)
h	hour(s)	Ω	ohm(s)
L	liter(s)		

COUNTRY AND AREA CODES

AT	Austria	GB	United Kingdom
AU	Australia	SEA-B1	Southeast Asia B1 (with Evaporative Emission Control System)
BR	Brazil	SEA-B2	Southeast Asia B2
CA	Canada	US	United States
CAL	California	WVTA (FULL H)	WVTA Model with Honeycomb Catalytic Converter (Full Power)
CH	Switzerland	GB WVTA (FULL H)	WVTA Model with Honeycomb Catalytic Converter (Left Side Traffic, Full Power)
DE	Germany	WVTA (78.2 H)	WVTA Model with Honeycomb Catalytic Converter (78.2 Kw Power)

EMISSION CONTROL INFORMATION

To protect the environment in which we all live, Kawasaki has incorporated crankcase emission (1) and exhaust emission (2) control systems in compliance with applicable regulations of the United States Environmental Protection Agency and California Air Resources Board. Additionally, Kawasaki has incorporated an evaporative emission control system (3) in compliance with applicable regulations of the California Air Resources Board on vehicles sold in California only.

1. Crankcase Emission Control System

This system eliminates the release of crankcase vapors into the atmosphere. Instead, the vapors are routed through an oil separator to the intake side of the engine. While the engine is operating, the vapors are drawn into combustion chamber, where they are burned along with the fuel and air supplied by the fuel injection system.

2. Exhaust Emission Control System

This system reduces the amount of pollutants discharged into the atmosphere by the exhaust of this motorcycle. The fuel, ignition, and exhaust systems of this motorcycle have been carefully designed and constructed to ensure an efficient engine with low exhaust pollutant levels.

The exhaust system of this model motorcycle manufactured primarily for sale in California includes a catalytic converter system.

3. Evaporative Emission Control System

Vapors caused by fuel evaporation in the fuel system are not vented into the atmosphere. Instead, fuel vapors are routed into the running engine to be burned, or stored in a canister when the engine is stopped. Liquid fuel is caught by a vapor separator and returned to the fuel tank.

The Clean Air Act, which is the Federal law covering motor vehicle pollution, contains what is commonly referred to as the Act's "tampering provisions".

"Sec. 203(a) The following acts and the causing thereof are prohibited.

(3)(A) for any person to remove or render inoperative any device or element of design installed on or in a motor vehicle or motor vehicle engine in compliance with regulations under this title prior to its sale and delivery to the ultimate purchaser, or for any manufacturer or dealer knowingly to remove or render inoperative any such device or element of design after such sale and delivery to the ultimate purchaser.

(3)(B) for any person engaged in the business of repairing, servicing, selling, leasing, or trading motor vehicles or motor vehicle engines, or who operates a fleet of motor vehicles knowingly to remove or render inoperative any device or element of design installed on or in a motor vehicle or motor vehicle engine in compliance with regulations under this title following its sale and delivery to the ultimate purchaser..."

NOTE

○ *The phrase "remove or render inoperative any device or element of design" has been generally interpreted as follows.*

1. *Tampering does not include the temporary removal or rendering inoperative of devices or elements of design in order to perform maintenance.*
2. *Tampering could include.*
 - a. *Maladjustment of vehicle components such that the emission standards are exceeded.*
 - b. *Use of replacement parts or accessories which adversely affect the performance or durability of the motorcycle.*
 - c. *Addition of components or accessories that result in the vehicle exceeding the standards.*
 - d. *Permanently removing, disconnecting, or rendering inoperative any component or element of design of the emission control systems.*

WE RECOMMEND THAT ALL DEALERS OBSERVE THESE PROVISIONS OF FEDERAL LAW, THE VIOLATION OF WHICH IS PUNISHABLE BY CIVIL PENALTIES NOT EXCEEDING \$10 000 PER VIOLATION.

TAMPERING WITH NOISE CONTROL SYSTEM PROHIBITED

Federal law prohibits the following acts or the causing thereof. (1) The removal or rendering inoperative by any person other than for purposes of maintenance, repair, or replacement, of any device or element of design incorporated into any new vehicle for the purpose of noise control prior to its sale or delivery to the ultimate purchaser or while it is in use, or (2) the use of the vehicle after such device or element of design has been removed or rendered inoperative by any person.

Among those acts presumed to constitute tampering are the acts listed below.

- Replacement of the original exhaust system or muffler with a component not in compliance with Federal regulations.
- Removal of the muffler(s) or any internal portion of the muffler(s).
- Removal of the air box or air box cover.
- Modifications to the muffler(s) or air intake system by cutting, drilling, or other means if such modifications result in increased noise levels.

Foreword

This manual is designed primarily for use by trained mechanics in a properly equipped shop. However, it contains enough detail and basic information to make it useful to the owner who desires to perform his own basic maintenance and repair work. A basic knowledge of mechanics, the proper use of tools, and workshop procedures must be understood in order to carry out maintenance and repair satisfactorily. Whenever the owner has insufficient experience or doubts his ability to do the work, all adjustments, maintenance, and repair should be carried out only by qualified mechanics.

In order to perform the work efficiently and to avoid costly mistakes, read the text, thoroughly familiarize yourself with the procedures before starting work, and then do the work carefully in a clean area. Whenever special tools or equipment are specified, do not use makeshift tools or equipment. Precision measurements can only be made if the proper instruments are used, and the use of substitute tools may adversely affect safe operation.

For the duration of the warranty period, we recommend that all repairs and scheduled maintenance be performed in accordance with this service manual. Any owner maintenance or repair procedure not performed in accordance with this manual may void the warranty.

To get the longest life out of your vehicle.

- Follow the Periodic Maintenance Chart in the Service Manual.
- Be alert for problems and non-scheduled maintenance.
- Use proper tools and genuine Kawasaki Motorcycle parts. Special tools, gauges, and testers that are necessary when servicing Kawasaki motorcycles are introduced by the Service Manual. Genuine parts provided as spare parts are listed in the Parts Catalog.
- Follow the procedures in this manual carefully. Don't take shortcuts.
- Remember to keep complete records of maintenance and repair with dates and any new parts installed.

How to Use This Manual

In this manual, the product is divided into its major systems and these systems make up the manual's chapters. The Quick Reference

Guide shows you all of the product's system and assists in locating their chapters. Each chapter in turn has its own comprehensive Table of Contents.

For example, if you want ignition coil information, use the Quick Reference Guide to locate the Electrical System chapter. Then, use the Table of Contents on the first page of the chapter to find the Ignition Coil section.

Whenever you see symbols, heed their instructions! Always follow safe operating and maintenance practices.

DANGER

DANGER indicates a hazardous situation which, if not avoided, will result in death or serious injury.

WARNING

WARNING indicates a hazardous situation which, if not avoided, could result in death or serious injury.

NOTICE

NOTICE is used to address practices not related to personal injury.

This manual contains four more symbols which will help you distinguish different types of information.

NOTE

○ *This note symbol indicates points of particular interest for more efficient and convenient operation.*

- Indicates a procedural step or work to be done.
- Indicates a procedural sub-step or how to do the work of the procedural step it follows. It also precedes the text of a NOTE.
- ★ Indicates a conditional step or what action to take based on the results of the test or inspection in the procedural step or sub-step it follows.

In most chapters an exploded view illustration of the system components follows the Table of Contents. In these illustrations you will find the instructions indicating which parts require specified tightening torque, oil, grease or a locking agent during assembly.

General Information

Table of Contents

Before Servicing	1-2
Model Identification.....	1-7
General Specifications.....	1-10
Unit Conversion Table	1-13

1-2 GENERAL INFORMATION

Before Servicing

Before starting to perform an inspection service or carry out a disassembly and reassembly operation on a motorcycle, read the precautions given below. To facilitate actual operations, notes, illustrations, photographs, cautions, and detailed descriptions have been included in each chapter wherever necessary. This section explains the items that require particular attention during the removal and reinstallation or disassembly and reassembly of general parts.

Especially note the following.

Battery Ground

Before completing any service on the motorcycle, disconnect the battery cables from the battery to prevent the engine from accidentally turning over. Disconnect the ground cable (-) first and then the positive (+). When completed with the service, first connect the positive (+) cable to the positive (+) terminal of the battery then the negative (-) cable to the negative terminal.

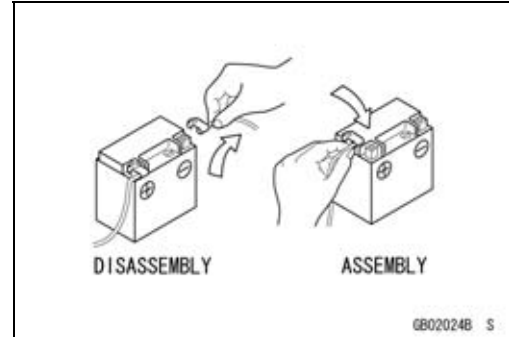

Edges of Parts

Lift large or heavy parts wearing gloves to prevent injury from possible sharp edges on the parts.

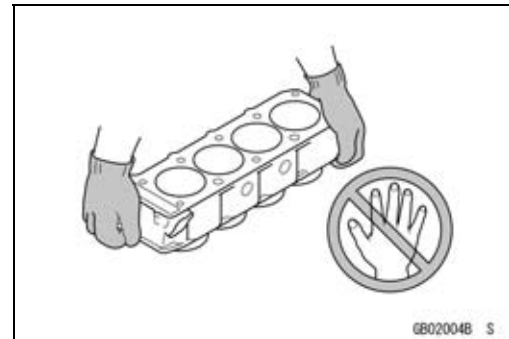

Solvent

Use a high-flash point solvent when cleaning parts. High-flash point solvent should be used according to directions of the solvent manufacturer.

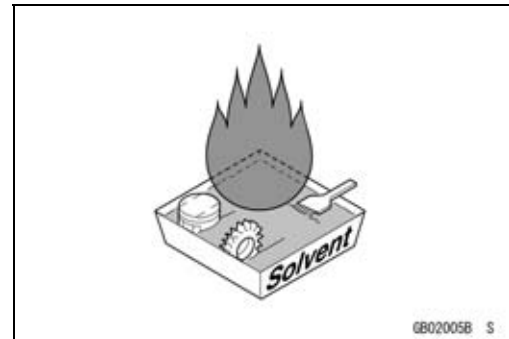

Cleaning Vehicle before Disassembly

Clean the vehicle thoroughly before disassembly. Dirt or other foreign materials entering into sealed areas during vehicle disassembly can cause excessive wear and decrease performance of the vehicle.

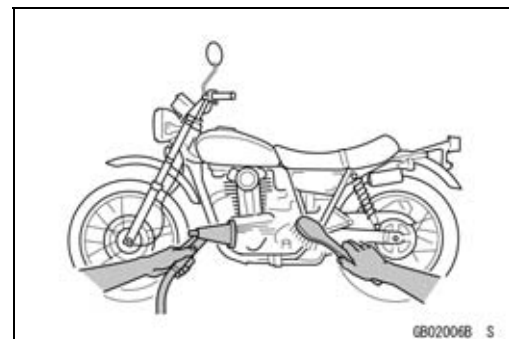

Before Servicing

Arrangement and Cleaning of Removed Parts

Disassembled parts are easy to confuse. Arrange the parts according to the order the parts were disassembled and clean the parts in order prior to assembly.

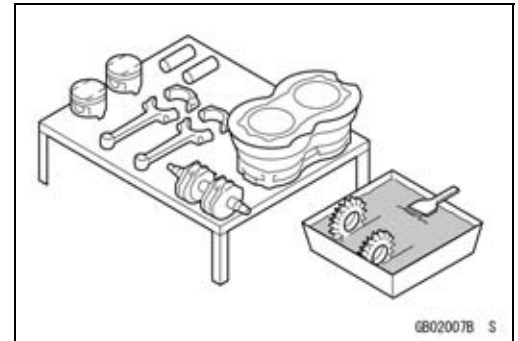

Storage of Removed Parts

After all the parts including subassembly parts have been cleaned, store the parts in a clean area. Put a clean cloth or plastic sheet over the parts to protect from any foreign materials that may collect before re-assembly.

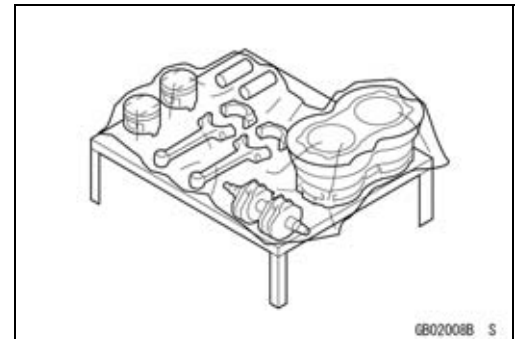

Inspection

Reuse of worn or damaged parts may lead to serious accident. Visually inspect removed parts for corrosion, discoloration, or other damage. Refer to the appropriate sections of this manual for service limits on individual parts. Replace the parts if any damage has been found or if the part is beyond its service limit.

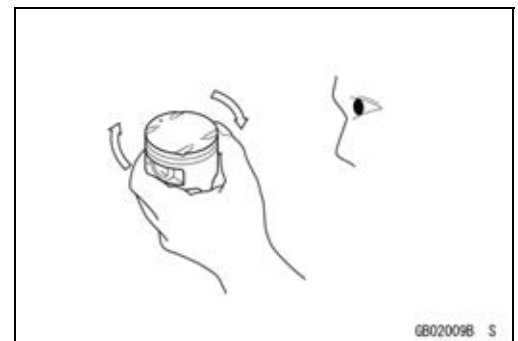

Replacement Parts

Replacement parts must be KAWASAKI genuine or recommended by KAWASAKI. Gaskets, O-rings, oil seals, grease seals, circlips, cotter pins or self-locking nuts must be replaced with new ones whenever disassembled.

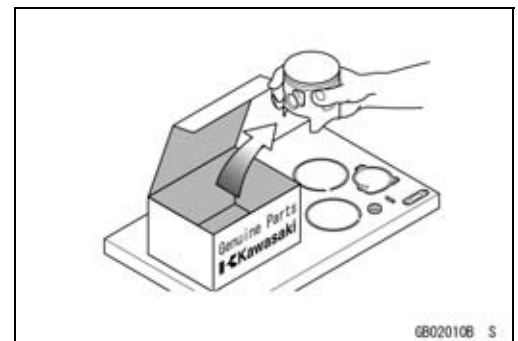

Assembly Order

In most cases assembly order is the reverse of disassembly, however, if assembly order is provided in this Service Manual, follow the procedures given.

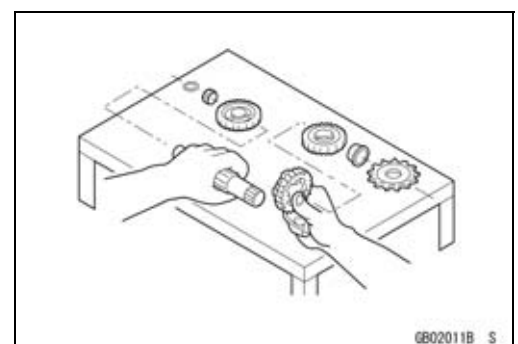

1-4 GENERAL INFORMATION

Before Servicing

Tightening Sequence

Generally, when installing a part with several bolts, nuts, or screws, start them all in their holes and tighten them to a snug fit. Then tighten them according to the specified sequence to prevent case warpage or deformation which can lead to malfunction. Conversely when loosening the bolts, nuts, or screws, first loosen all of them by about a quarter turn and then remove them. If the specified tightening sequence is not indicated, tighten the fasteners alternating diagonally.

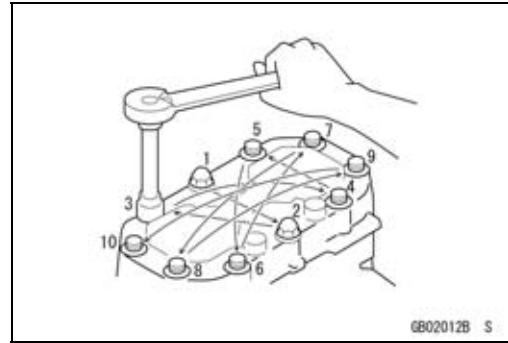

Tightening Torque

Incorrect torque applied to a bolt, nut, or screw may lead to serious damage. Tighten fasteners to the specified torque using a good quality torque wrench.

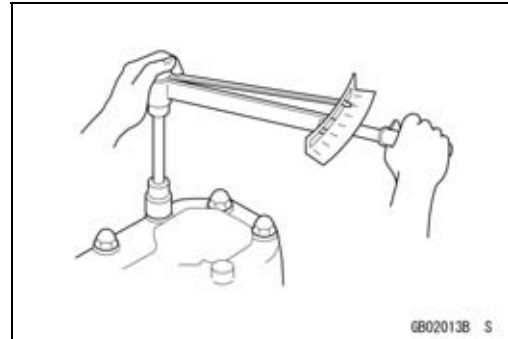

Force

Use common sense during disassembly and assembly, excessive force can cause expensive or hard to repair damage. When necessary, remove screws that have a non-permanent locking agent applied using an impact driver. Use a plastic-faced mallet whenever tapping is necessary.

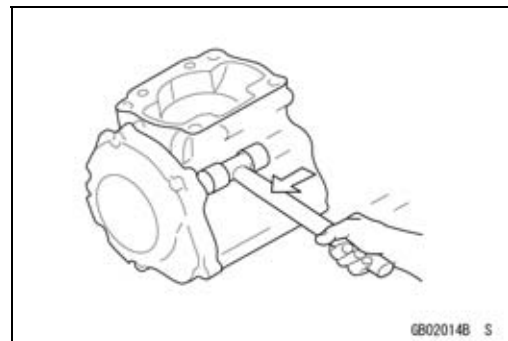

Gasket, O-ring

Hardening, shrinkage, or damage of both gaskets and O-rings after disassembly can reduce sealing performance. Remove old gaskets and clean the sealing surfaces thoroughly so that no gasket material or other material remains. Install the new gaskets and replace the used O-rings when re-assembling.

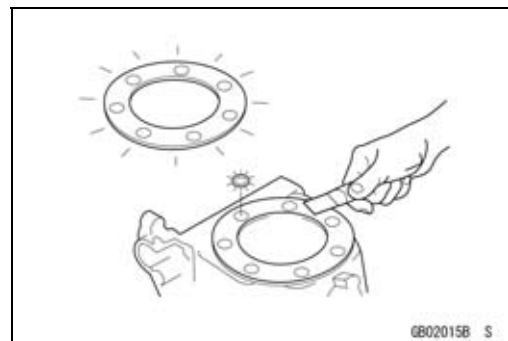

Liquid Gasket, Non-permanent Locking Agent

For applications that require Liquid Gasket or a Non-permanent Locking Agent, clean the surfaces so that no oil residue remains before applying liquid gasket or non-permanent locking agent. Do not apply them excessively. Excessive application can clog oil passages and cause serious damage.



Before Servicing

Press

For items such as bearings or oil seals that must be pressed into place, apply small amount of oil to the contact area. Be sure to maintain proper alignment and use smooth movements when installing.

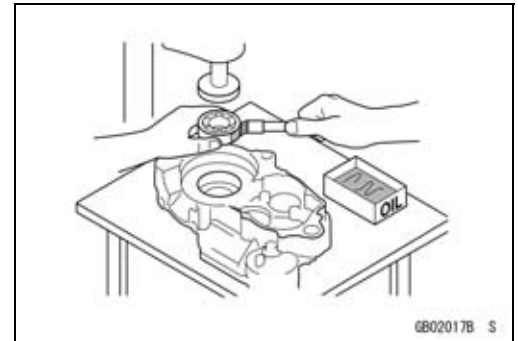

Ball Bearing and Needle Bearing

Do not remove pressed ball or needle unless removal is absolutely necessary. Replace with new ones whenever removed. Press bearings with the manufacturer and size marks facing out. Press the bearing into place by putting pressure on the correct bearing race as shown.

Pressing the incorrect race can cause pressure between the inner and outer race and result in bearing damage.

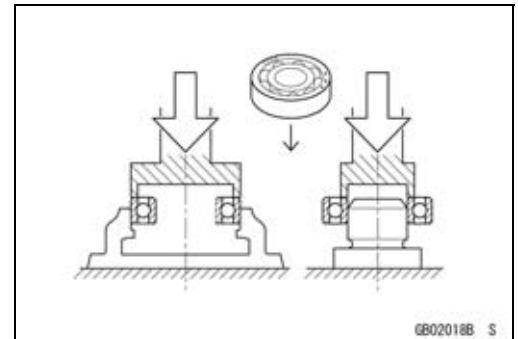

Oil Seal, Grease Seal

Do not remove pressed oil or grease seals unless removal is necessary. Replace with new ones whenever removed. Press new oil seals with manufacture and size marks facing out. Make sure the seal is aligned properly when installing.

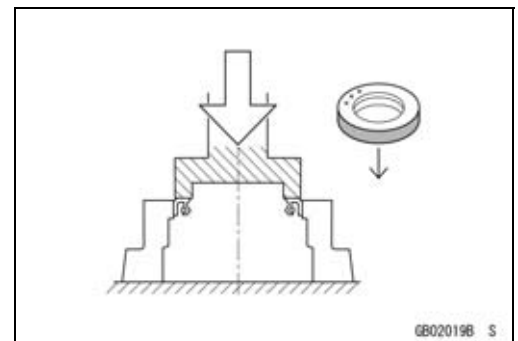

Apply specified grease to the lip of seal before installing the seal.

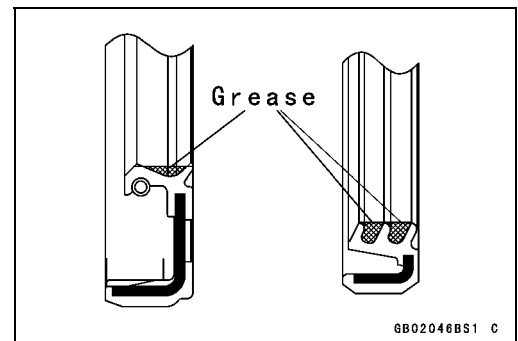

Circlips, Cotter Pins

Replace the circlips or cotter pins that were removed with new ones. Take care not to open the clip excessively when installing to prevent deformation.

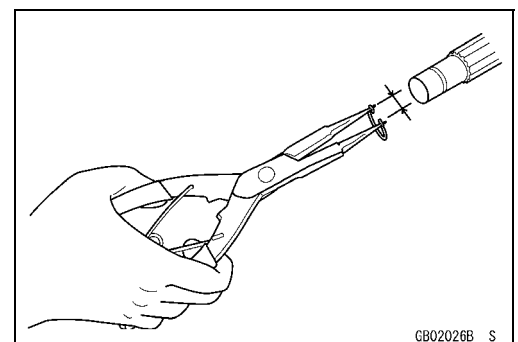

1-6 GENERAL INFORMATION

Before Servicing

Lubrication

It is important to lubricate rotating or sliding parts during assembly to minimize wear during initial operation. Lubrication points are called out throughout this manual, apply the specific oil or grease as specified.

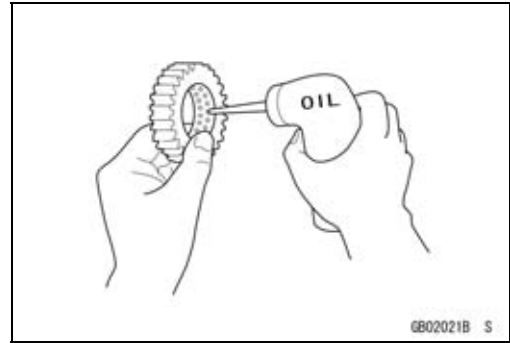

Direction of Engine Rotation

When rotating the crankshaft by hand, the free play amount of rotating direction will affect the adjustment. Rotate the crankshaft to positive direction (clockwise viewed from output side).

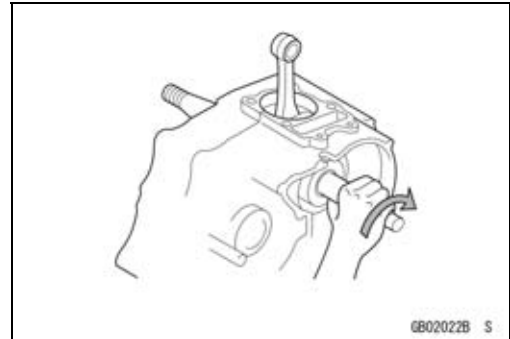

Electrical Wires

A two-color wire is identified first by the primary color and then the stripe color. Unless instructed otherwise, electrical wires must be connected to those of the same color.

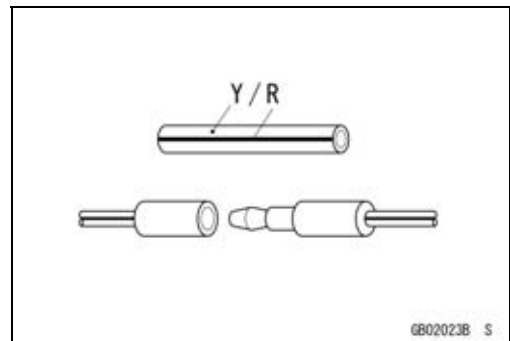

Instrument

Use a meter that has enough accuracy for an accurate measurement. Read the manufacture's instructions thoroughly before using the meter. Incorrect values may lead to improper adjustments.

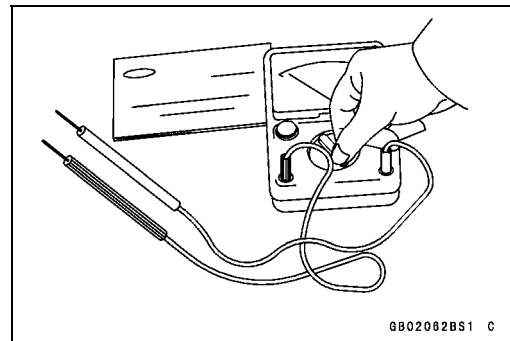

Model Identification

ZX1000GB (United States and Canada) Left Side View



ZX1000GB (United States and Canada) Right Side View



Frame Number



Engine Number



1-8 GENERAL INFORMATION

Model Identification

ZX1000GB (Europe) Left Side View



ZX1000GB (Europe) Right Side View



Model Identification

ZX1000HB Left Side View



ZX1000HB Right Side View



1-10 GENERAL INFORMATION

General Specifications

Items	ZX1000GB ~ GC/HB ~ HC
Dimensions Overall Length Overall Width Overall Height/High Position Wheelbase Road Clearance Seat Height Curb Mass: ZX1000G ZX1000H Front: ZX1000G ZX1000H Rear: ZX1000G ZX1000H Fuel Tank Capacity	2 105 mm (82.87 in.) 790 mm (31.1 in.) 1 170 mm (40.06 in.)/1 230 mm (48.43 in.) 1 445 mm (56.89 in.) 135 mm (5.31 in.) 820 mm (32.28 in.) 228 kg (503 lb) 231 kg (509 lb) 117 kg (258 lb) 118 kg (260 lb) 111 kg (245 lb) 113 kg (249 lb) 19 L (5.0 US gal.)
Performance Minimum Turning Radius	3.1 m (10.1 ft)
Engine Type Cooling System Bore and Stroke Displacement Compression Ratio Maximum Horsepower Maximum Torque Carburetion System Starting System Ignition System Timing Advance Ignition Timing Spark Plug Cylinder Numbering Method Firing Order Valve Timing: Intake: Open Close	4-stroke, DOHC, 4-cylinder Liquid-cooled 77.0 x 56.0 mm (3.03 x 2.20 in.) 1 043 cm ³ (63.64 cu in.) 11.8 : 1 101.5 kW (138 PS) @9 600 r/min (rpm) (SEA-B1/B2) 100 kW (136 PS) @9 000 r/min (rpm) (WVTA (78.2 H)) 78.2 kW (106 PS) @9 100 r/min (rpm) (CA, US) – – – 110 N·m (11.2 kgf·m, 81.1 ft·lb) @7 800 r/min (rpm) (WVTA (78.2 H)) 95 N·m (9.7 kgf·m, 70 ft·lb) @7 500 r/min (rpm) (CA, US) – – – FI (Fuel Injection) KEIHIN TTK38 x 4 Electric starter Battery and coil (transistorized) Electronically advanced (digital igniter) From 10° BTDC @1 100 r/min (rpm) to 40.2° BTDC @5 200 r/min (rpm) NGK CR9EIA-9 Left to right, 1-2-3-4 1-2-4-3 31° BTDC 65° ABDC

General Specifications

Items	ZX1000GB ~ GC/HB ~ HC
Duration Exhaust: Open Close Duration Lubrication System Engine Oil: Type Viscosity Capacity	276° 58° BBDC 18° ATDC 256° Forced lubrication (wet sump) API SG, SH, SJ, SL or SM with JASO MA, MA1 or MA2 SAE 10W-40 4.0 L (4.2 US qt)
Drive Train Primary Reduction System: Type Reduction Ratio Clutch Type Transmission: Type Gear Ratios: 1st 2nd 3rd 4th 5th 6th Final Drive System: Type Reduction Ratio Overall Drive Ratio	Gear 1.627 (83/51) Wet multi disc 6-speed, constant mesh, return shift 2.600 (39/15) 1.950 (39/20) 1.600 (24/15) 1.389 (25/18) 1.238 (26/21) 1.136 (25/22) Chain drive 2.733 (41/15) 5.055 @Top gear
Frame Type Caster (Rake Angle) Trail Front Tire: Type Size Rim Size Rear Tire: Type Size Rim Size Front Suspension: Type Wheel Travel	Tubular, diamond 24.5° 102 mm (4.02 in.) Tubeless 120/70 ZR17 M/C (58W) J17M/C × MT3.50 Tubeless 190/50 ZR17 M/C (73W) J17M/C × MT6.00 Telescopic fork (upside-down) 120 mm (4.72 in.)

1-12 GENERAL INFORMATION

General Specifications

Items	ZX1000GB ~ GC/HB ~ HC
Rear Suspension: Type Wheel Travel Brake Type: Front Rear	Swingarm 138 mm (5.43 in.) Dual discs Single disc
Electrical Equipment Battery Headlight: Type High Beam Low Beam Tail/Brake Light Alternator: Type	12 V 8 Ah Semi-sealed beam 12 V 55 W 12 V 55 W LED Three-phase AC

Specifications are subject to change without notice, and may not apply to every country.

Unit Conversion Table

Prefixes for Units:

Prefix	Symbol	Power
mega	M	× 1 000 000
kilo	k	× 1 000
centi	c	× 0.01
milli	m	× 0.001
micro	μ	× 0.000001

Units of Mass:

kg	×	2.205	=	lb
g	×	0.03527	=	oz

Units of Volume:

L	×	0.2642	=	gal (US)
L	×	0.2200	=	gal (IMP)
L	×	1.057	=	qt (US)
L	×	0.8799	=	qt (IMP)
L	×	2.113	=	pint (US)
L	×	1.816	=	pint (IMP)
mL	×	0.03381	=	oz (US)
mL	×	0.02816	=	oz (IMP)
mL	×	0.06102	=	cu in

Units of Force:

N	×	0.1020	=	kg
N	×	0.2248	=	lb

kg	×	9.807	=	N
kg	×	2.205	=	lb

Units of Length:

km	×	0.6214	=	mile
m	×	3.281	=	ft
mm	×	0.03937	=	in

Units of Torque:

N·m	×	0.1020	=	kgf·m
N·m	×	0.7376	=	ft·lb
N·m	×	8.851	=	in·lb

kgf·m	×	9.807	=	N·m
kgf·m	×	7.233	=	ft·lb
kgf·m	×	86.80	=	in·lb

Units of Pressure:

kPa	×	0.01020	=	kgf/cm ²
kPa	×	0.1450	=	psi
kPa	×	0.7501	=	cmHg

kgf/cm ²	×	98.07	=	kPa
kgf/cm ²	×	14.22	=	psi
cmHg	×	1.333	=	kPa

Units of Speed:

km/h	×	0.6214	=	mph
------	---	--------	---	-----

Units of Power:

kW	×	1.360	=	PS
kW	×	1.341	=	HP

PS	×	0.7355	=	kW
PS	×	0.9863	=	HP

Units of Temperature:

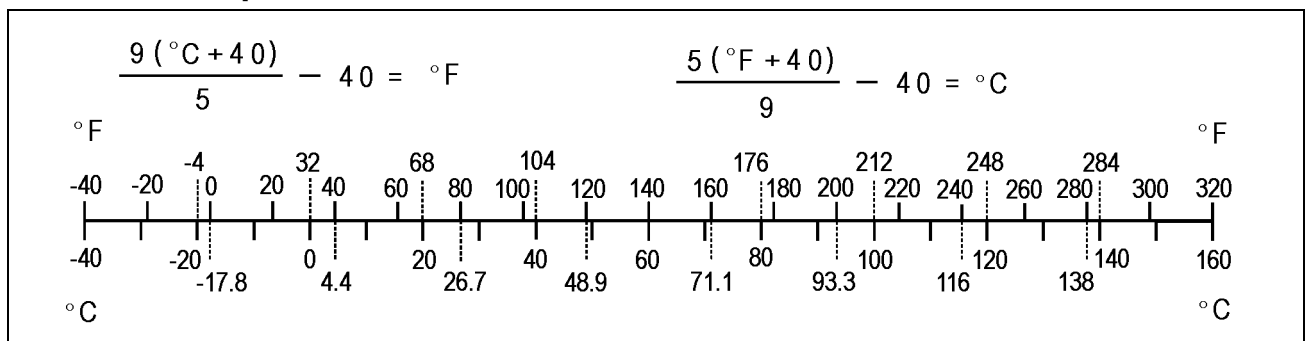

Periodic Maintenance

Table of Contents

Periodic Maintenance Chart	2-3
Torque and Locking Agent	2-7
Specifications	2-13
Special Tools	2-15
Periodic Maintenance Procedures.....	2-17
Fuel System (DFI).....	2-17
Throttle Control System Inspection.....	2-17
Engine Vacuum Synchronization Inspection.....	2-17
Idle Speed Inspection	2-21
Idle Speed Adjustment.....	2-22
Fuel Hose Inspection (fuel leak, damage, installation condition)	2-22
Evaporative Emission Control System (CAL and SEA-B1 Models) Inspection.....	2-23
Cooling System.....	2-24
Coolant Level Inspection.....	2-24
Radiator Hose and Pipe Inspection (coolant leak, damage, installation condition)	2-24
Engine Top End	2-24
Valve Clearance Inspection	2-24
Valve Clearance Adjustment.....	2-26
Air Suction System Damage Inspection.....	2-29
Clutch.....	2-30
Clutch Operation Inspection.....	2-30
Wheels/Tires.....	2-31
Air Pressure Inspection.....	2-31
Wheel/Tire Damage Inspection.....	2-31
Tire Tread Wear Inspection.....	2-31
Wheel Bearing Damage Inspection	2-32
Final Drive.....	2-33
Drive Chain Lubrication Condition Inspection	2-33
Drive Chain Slack Inspection	2-33
Drive Chain Slack Adjustment	2-34
Wheel Alignment Inspection	2-34
Wheel Alignment Adjustment.....	2-34
Drive Chain Wear Inspection	2-35
Chain Guide Wear Inspection	2-35
Brakes.....	2-36
Brake Fluid Leak (Brake Hose and Pipe) Inspection	2-36
Brake Hose and Pipe Damage and Installation Condition.....	2-37
Brake Operation Inspection	2-37
Brake Fluid Level Inspection.....	2-37
Brake Pad Wear Inspection	2-38
Brake Light Switch Operation Inspection	2-39
Suspension.....	2-40
Front Forks/Rear Shock Absorber Operation Inspection	2-40
Front Fork Oil Leak Inspection.....	2-40
Rear Shock Absorber Oil Leak Inspection	2-40
Rocker Arm Operation Inspection.....	2-40
Tie-Rod Operation Inspection	2-41
Steering	2-41
Steering Play Inspection	2-41
Steering Play Adjustment.....	2-41

2-2 PERIODIC MAINTENANCE

Steering Stem Bearing Lubrication	2-43
Electrical System	2-44
Lights and Switches Operation Inspection.....	2-44
Headlight Aiming Inspection	2-46
Sidestand Switch Operation Inspection	2-47
Engine Stop Switch Operation Inspection.....	2-48
Others	2-49
Chassis Parts Lubrication	2-49
Bolts, Nuts and Fasteners Tightness Inspection.....	2-51
Replacement Parts	2-52
Air Cleaner Element Replacement.....	2-52
Fuel Hose Replacement	2-52
Coolant Change	2-54
Radiator Hose and O-ring Replacement.....	2-56
Engine Oil Change.....	2-57
Oil Filter Replacement	2-57
Brake Hose Replacement.....	2-58
Brake Fluid Change	2-59
Master Cylinder Rubber Parts Replacement	2-61
Caliper Rubber Parts Replacement	2-62
Spark Plug Replacement	2-66

Periodic Maintenance Chart

The scheduled maintenance must be done in accordance with this chart to keep the motorcycle in good running condition. **The initial maintenance is vitally important and must not be neglected.**

Periodic Inspection

ITEM	FREQUENCY	* ODOMETER READING × 1 000 km (× 1 000 mile)							See Page
	Whichever comes first ↓	1 (0.6)	6 (3.75)	12 (7.5)	18 (11.25)	24 (15)	30 (18.75)	36 (22.5)	
Fuel System									
Throttle control system (play, smooth return, no drag) - inspect	year	●		●		●		●	2-17
Engine vacuum synchronization - inspect				●		●		●	2-17
Idle speed - inspect		●		●		●		●	2-21
Fuel leak (fuel hose and pipe) - inspect	year	●		●		●		●	2-22
Fuel hose and pipe damage - inspect	year	●		●		●		●	2-22
Fuel hose and pipe installation condition - inspect	year	●		●		●		●	2-22
Evaporative emission control system function (CAL), (SEA-B1) - inspect		●	●	●	●	●	●	●	2-23
Cooling System									
Coolant level - inspect		●		●		●		●	2-24
Coolant leak (water hose and pipe) - inspect	year	●		●		●		●	2-24
Water hose damage - inspect	year	●		●		●		●	2-24
Water hose installation condition - inspect	year	●		●		●		●	2-24
Engine Top End									
Valve clearance - inspect	US, CA, CAL Model					●			2-24
	Other than US, CA, CAL Models	Every 42 000 km (26 250 mile)							2-24
Air suction system damage - inspect				●		●		●	2-29
Clutch									
Clutch operation (play, disengagement, engagement) - inspect		●		●		●		●	2-30
Wheels and Tires									
Tire air pressure - inspect	year			●		●		●	2-31
Wheel/tire damage - inspect				●		●		●	2-31
Tire tread wear, abnormal wear - inspect				●		●		●	2-31
Wheel bearing damage - inspect	year			●		●		●	2-32

2-4 PERIODIC MAINTENANCE

Periodic Maintenance Chart

ITEM	FREQUENCY	* ODOMETER READING × 1 000 km (× 1 000 mile)							See Page
		Whichever comes first ↓ Every	1 (0.6)	6 (3.75)	12 (7.5)	18 (11.25)	24 (15)	30 (18.75)	
Final Drive									
Drive chain lubrication condition - inspect #		Every 600 km (400 mile)							2-33
Drive chain slack - inspect #		Every 1 000 km (600 mile)							2-33
Drive chain wear - inspect #				●		●		●	2-35
Drive chain guide wear - inspect				●		●		●	2-35
Brakes									
Brake fluid leak (brake hose and pipe) - inspect	year	●	●	●	●	●	●	●	2-36
Brake hose and pipe damage - inspect	year	●	●	●	●	●	●	●	2-37
Brake hose and pipe installation condition - inspect	year	●	●	●	●	●	●	●	2-37
Brake operation (effectiveness, play, no drag) - inspect	year	●	●	●	●	●	●	●	2-37
Brake fluid level - inspect	6 months	●	●	●	●	●	●	●	2-37
Brake pad wear - inspect #			●	●	●	●	●	●	2-38
Brake light switch operation - inspect		●	●	●	●	●	●	●	2-39
Suspension									
Front forks/rear shock absorber operation (damping and smooth stroke) - inspect				●		●		●	2-40
Front forks/rear shock absorber oil leak - inspect	year			●		●		●	2-40
Rocker arm operation - inspect				●		●		●	2-40
Tie-rods operation - inspect				●		●		●	2-41
Steering									
Steering play - inspect	year	●		●		●		●	2-41
Steering stem bearings - lubricate	2 years					●			2-43
Electrical System									
Lights and switches operation - inspect	year			●		●		●	2-44
Headlight aiming - inspect	year			●		●		●	2-46
Sidestand switch operation - inspect	year			●		●		●	2-47
Engine stop switch operation - inspect	year			●		●		●	2-48
Others									
Chassis parts - lubricate	year			●		●		●	2-49
Bolts and nuts tightness - inspect		●		●		●		●	2-51

Periodic Maintenance Chart

- #: Service more frequently when operating in severe conditions; dusty, wet, muddy, high speed or frequent starting/stopping.
- *: For higher odometer readings, repeat at the frequency interval established here.

2-6 PERIODIC MAINTENANCE

Periodic Maintenance Chart

Periodic Replacement Parts

ITEM	FREQUENCY	Whichever comes first ↓ Every	* ODOMETER READING × 1 000 km (× 1 000 mile)					See Page
			1 (0.6)	12 (7.5)	24 (15)	36 (22.5)	48 (30)	
Air cleaner element # - replace		Every 18 000 km (11 250 mile)						2-52
Fuel hose - replace	5 years							2-52
Coolant - change	3 years				●			2-54
Radiator hose and O-ring - replace	3 years				●			2-56
Engine oil # - change	year	●	●	●	●	●		2-57
Oil filter - replace	year	●	●	●	●	●		2-57
Brake hose - replace	4 years					●		2-58
Brake fluid - change	2 years			●		●		2-59
Rubber parts of master cylinder and caliper - replace	4 years					●		2-61, 2-62
Spark plug - replace			●	●	●	●		2-66

#: Service more frequently when operating in severe conditions; dusty, wet, muddy, high speed or frequent starting/stopping.

*: For higher odometer readings, repeat at the frequency interval established here.

Torque and Locking Agent

The following tables list the tightening torque for the major fasteners requiring use of a non-permanent locking agent or silicone sealant etc.

Letters used in the “Remarks” column mean:

AL: Tighten the two clamp bolts alternately two times to ensure even tightening torque.

G: Apply grease.

L: Apply a non-permanent locking agent.

MO: Apply molybdenum disulfide oil solution.

(mixture of the engine oil and molybdenum disulfide grease in a weight ratio 10 : 1)

R: Replacement Parts

S: Follow the specified tightening sequence.

Si: Apply silicone grease (ex. PBC grease).

SS: Apply silicone sealant.

Fastener	Torque			Remarks
	N·m	kgf·m	ft·lb	
Fuel System (DFI)				
Upper Air Cleaner Housing Screws	1.1	0.11	9.7 in·lb	
Throttle Body Assy Holder Clamp Bolts	2.9	0.30	26 in·lb	
Air Cleaner Duct Clamp Bolts	2.0	0.20	18 in·lb	
Delivery Pipe Assy Mounting Screws	3.4	0.35	30 in·lb	
Oxygen Sensor (Equipped Models)	44	4.5	32	
Intake Air Temperature Sensor Mounting Screw	1.2	0.12	11 in·lb	
Water Temperature Sensor	30	3.0	22	
Exhaust Butterfly Valve Actuator Pulley Bolt	5.0	0.51	44 in·lb	
Exhaust Butterfly Valve Actuator Mounting Screws	1.2	0.12	11 in·lb	
Fuel Pump Bolts	9.8	1.0	87 in·lb	L
Cooling System				
Hot Windshield Mounting Bolts	9.8	1.0	87 in·lb	
Coolant By-pass Fitting Bolt	8.8	0.90	78 in·lb	L
Thermostat Housing Bolts	5.9	0.60	52 in·lb	L
Radiator (Water) Hose Clamp Screws	2.9	0.30	26 in·lb	
Water Pipe Bolts	12	1.2	106 in·lb	L
Water Pump Impeller Bolt	9.8	1.0	87 in·lb	
Water Pump Cover Bolts	11	1.1	97 in·lb	
Coolant Drain Bolt	11	1.1	97 in·lb	
Engine Top End				
Air Suction Valve Cover Bolts	9.8	1.0	87 in·lb	L
Spark Plugs	13	1.3	115 in·lb	
Cylinder Head Cover Bolts	9.8	1.0	87 in·lb	S
Hot Windshield Mounting Bolts	9.8	1.0	87 in·lb	
Camshaft Sprocket Bolts	15	1.5	11	L
Front Camshaft Chain Guide Bolt (Upper)	25	2.5	18	
Rear Camshaft Chain Guide Bolt	25	2.5	18	
Front Camshaft Chain Guide Bolt (Lower)	12	1.2	106 in·lb	
Throttle Body Assy Holder Bolts	12	1.2	106 in·lb	L

2-8 PERIODIC MAINTENANCE

Torque and Locking Agent

Fastener	Torque			Remarks
	N·m	kgf·m	ft·lb	
Cylinder Head Bolts (M6)	12	1.2	106 in·lb	S
Upper Camshaft Chain Guide Bolts	12	1.2	106 in·lb	S
Plugs	19.6	2.0	14	L
Camshaft Cap Bolts	12	1.2	106 in·lb	S
Cylinder Head Bolts (M10) (First)	20	2.0	15	S, MO
Cylinder Head Bolts (M10) (Final)	54	5.5	40	S, MO
Camshaft Chain Tensioner Mounting Bolts	11	1.1	97 in·lb	
Camshaft Chain Tensioner Cap Bolt	20	2.0	15	
Exhaust Butterfly Valve Actuator Pulley Bolt	5.0	0.51	44 in·lb	
Exhaust Butterfly Valve Actuator Bolts	1.2	0.12	11 in·lb	
Muffler Body Mounting Bolts	34	3.5	25	
Premuffler Chamber Mounting Bolt	34	3.5	25	
Muffler Body Clamp Bolts	21	2.1	15	
Clutch				
Clutch Lever Assembly Clamp Bolts	7.8	0.80	69 in·lb	S
Clutch Cover Bolts	9.8	1.0	87 in·lb	
Oil Filler Plug	2.0	0.20	18 in·lb	
Clutch Spring Bolts	9.0	0.90	80 in·lb	
Clutch Hub Nut	135	13.8	99.6	R
Engine Lubrication System				
Oil Filler Plug	2.0	0.20	18 in·lb	
Oil Cooler Bolts	12	1.2	106 in·lb	
Oil Passage Plug	20	2.0	15	L
Radiator (Water) Hose Clamp Screws	3.0	0.31	27 in·lb	
Oil Pressure Switch	15	1.5	11	SS
Oil Pressure Relief Valve	15	1.5	11	L
Oil Filter	17	1.7	13	G, R
Oil Filter Pipe	25	2.5	18	L
Oil Pan Bolts	12	1.2	106 in·lb	S
Engine Oil Drain Bolt	29	3.0	21	
Engine Removal/Installation				
Upper Engine Bracket Bolts	44	4.5	32	S
Lower Engine Bracket Bolts	59	6.0	44	S
Upper Adjusting Collar	9.8	1.0	87 in·lb	S
Upper Engine Mounting Bolt (L = 65)	44	4.5	32	S
Upper Adjusting Collar Locknut	49	5.0	36	S
Upper Engine Mounting Bolt (L = 40)	44	4.5	32	S
Lower Engine Mounting Nut	44	4.5	32	S
Lower Adjusting Collar Locknut	49	5.0	36	S
Middle Engine Bracket Bolts	25	2.5	18	L, S
Middle Engine Mounting Nut	44	4.5	32	S
Lower Adjusting Collar	9.8	1.0	87 in·lb	S

Torque and Locking Agent

Fastener	Torque			Remarks
	N-m	kgf-m	ft-lb	
Crankshaft/Transmission				
Balancer Shaft Clamp Bolt	9.8	1.0	87 in-lb	
Balancer Shaft Lever Bolt	25	2.5	18	L
Breather Side Plate Bolt	5.9	0.60	52 in-lb	L
Connecting Rod Big End Nuts	see the text	←	←	MO
Breather Plate Bolts	9.8	1.0	87 in-lb	L
Shift Drum Bearing Holder Bolts	12	1.2	106 in-lb	L
Oil Passage Plugs	20	2.0	15	L
Oil Passage Plug	9.8	1.0	87 in-lb	
Starter Motor Clutch Bolts	12	1.2	106 in-lb	L
Crankcase Bolts (M7)	20	2.0	15	S
Crankcase Bolts (M9)	42	4.2	31	S, MO
Crankcase Bolts (M6)	20	2.0	15	S
Crankcase Bolts (M8)	27	2.8	20	S
Gear Positioning Lever Bolt	12	1.2	106 in-lb	
Shift Drum Cam Bolt	12	1.2	106 in-lb	L
Neutral Switch	15	1.5	11	
Shift Shaft Return Spring Pin	39	4.0	29	L
Shift Pedal Mounting Bolt	25	2.5	18	
Wheels/Tires				
Front Axle Clamp Bolt	20	2.0	15	AL
Front Axle	108	11.0	79.7	
Rear Axle Nut	98	10	72	
Final Drive				
Engine Sprocket Nut	125	12.7	92.2	MO
Drive Chain Guide Bolts	9.8	1.0	87 in-lb	
Speed Sensor Mounting Bolt	6.9	0.70	61 in-lb	L
Chain Adjuster Clamp Bolts	64	6.5	47	
Rear Sprocket Nuts	59	6.0	44	
Brakes				
Front Master Cylinder Reservoir Cap Stopper Screw	1.2	0.12	11 in-lb	
Brake Lever Pivot Bolt	1.0	0.10	8.8 in-lb	Si
Front Master Cylinder Bleed Valve	5.4	0.55	48 in-lb	
Front Master Cylinder Clamp Bolts	11	1.1	97 in-lb	S
Brake Lever Pivot Bolt Locknut	5.9	0.60	52 in-lb	
Front Brake Light Switch Screw	1.2	0.12	11 in-lb	
Brake Hose Banjo Bolts	25	2.5	18	
Front Caliper Assembly Bolts	22	2.2	16	
Front Caliper Mounting Bolts	34	3.5	25	
Bleed Valves	7.8	0.80	69 in-lb	
Front Brake Pad Pins	15	1.5	11	
Front Brake Disc Mounting Bolts	27	2.8	20	L

2-10 PERIODIC MAINTENANCE

Torque and Locking Agent

Fastener	Torque			Remarks
	N-m	kgf-m	ft-lb	
Rear Master Cylinder Mounting Bolts	25	2.5	18	
Brake Pedal Bolt	8.8	0.90	78 in-lb	L
Rear Master Cylinder Push Rod Locknut	17	1.7	12	
Rear Brake Disc Mounting Bolts	27	2.8	20	L
Rear Caliper Mounting Bolts	25	2.5	18	
Brake Pipe Joint Nuts	18	1.8	13	
Rear Brake Disc Mounting Bolts (ABS Equipped Models)	27	2.8	20	L
Suspension				
Upper Front Fork Clamp Bolts	20	2.0	15	
Lower Front Fork Clamp Bolts	25	2.5	18	AL
Piston Rod Nuts	20	2.0	15	
Front Fork Top Plugs	34	3.5	25	
Front Axle Clump Bolts	20	2.0	15	AL
Front Fork Bottom Allen Bolts	35	3.6	26	
Rear Shock Absorber Bolt (Upper)	34	3.5	25	
Tie-rod Nuts	34	3.5	25	R
Rear Shock Absorber Nut (Lower)	34	3.5	25	R
Rocker Arm Nut	34	3.5	25	R
Swingarm Pivot Adjusting Collar Locknut	98	10	72	
Swingarm Pivot Shaft Nut	108	11.0	79.7	
Torque Link Nuts	34	3.5	25	
Steering				
Left Switch Housing Screws	3.5	0.36	31 in-lb	
Upper Front Fork Clamp Bolts	25	2.5	18	
Handlebar Holder Bolts	25	2.5	18	
Handlebar Bolts	34	3.5	25	L
Right Switch Housing Screws	3.5	0.36	31 in-lb	
Steering Stem Head Bolt	108	11.0	79.7	
Steering Stem Nut	25	2.5	18	
Lower Front Fork Clamp Bolts	20	2.0	15	AL
Frame				
Lower Fairing Upper Assembly Screws	1.2	0.12	11 in-lb	
Lower Fairing Lower Assembly Screws	1.2	0.12	11 in-lb	
Front Fender Mounting Bolts	3.9	0.40	35 in-lb	
Stay Assembly Mounting Bolts	6.9	0.70	61 in-lb	
Stopper Mounting Bolts	4.2	0.42	37 in-lb	L
Rear Frame Bracket Bolts	44	4.5	32	
Front Footpeg Bracket Bolts	25	2.5	18	
Rear Footpeg Bracket Bolts	25	2.5	18	
Rear Frame Bolts	25	2.5	18	L
Sidestand Switch Bolt	8.8	0.90	78 in-lb	L
Sidestand Bracket Bolts	49	5.0	36	L

Torque and Locking Agent

Fastener	Torque			Remarks
	N-m	kgf-m	ft-lb	
Sidestand Bolt	44	4.5	32	
Grab Rail Mounting Bolts	25	2.5	18 ft-lb	
Electrical System				
Switch Housing Screws	3.5	0.36	31 in-lb	
Oxygen Sensor (Equipped Models)	44	4.5	32	
Front Brake Light Switch Screw	1.2	0.12	11 in-lb	
Front Turn Signal Light Mounting Screws	1.2	0.12	11 in-lb	
Licence Plate Light Mounting Screws	1.2	0.12	11 in-lb	
Intake Air Temperature Sensor Mounting Screw	1.2	0.12	11 in-lb	
Spark Plugs	13	1.3	115 in-lb	
Crankshaft Sensor Cover Bolts	12	1.2	106 in-lb	
Water Temperature Sensor	30	3.0	22	
Timing Rotor Bolt	39	4.0	29	
Crankshaft Sensor Bolts	5.9	0.60	52 in-lb	
Starter Motor Cable Terminal Nut	5.9	0.60	52 in-lb	
Starter Motor Terminal Locknut	11	1.1	97 in-lb	
Starter Motor Mounting Bolts	9.8	1.0	87 in-lb	
Alternator Rotor Bolt	155	15.8	114	
Stator Coil Bolts	12	1.2	106 in-lb	L
Starter Motor Through Bolts	4.9	0.50	43 in-lb	
Brush Holder Screw	3.8	0.39	34 in-lb	
Oil Pressure Switch	15	1.5	11	SS
Oil Pressure Switch Terminal Bolt	2.0	0.20	18 in-lb	G
Alternator Cover Bolts	12	1.2	106 in-lb	
Alternator Lead Holding Plate Bolt	12	1.2	106 in-lb	L
Neutral Switch	15	1.5	11	
Engine Ground Cable Terminal Bolt	9.8	1.0	87 in-lb	
Sidestand Switch Bolt	8.8	0.90	78 in-lb	L
Speed Sensor Mounting Bolt	6.9	0.70	61 in-lb	L

2-12 PERIODIC MAINTENANCE

Torque and Locking Agent

The table below, relating tightening torque to thread diameter, lists the basic torque for the bolts and nuts. Use this table for only the bolts and nuts which do not require a specific torque value. All of the values are for use with dry solvent-cleaned threads.

Basic Torque for General Fasteners

Threads Diameter (mm)	Torque		
	N·m	kgf·m	ft·lb
5	3.4 ~ 4.9	0.35 ~ 0.50	30 ~ 43 in·lb
6	5.9 ~ 7.8	0.60 ~ 0.80	52 ~ 69 in·lb
8	14 ~ 19	1.4 ~ 1.9	10.0 ~ 13.5
10	25 ~ 34	2.6 ~ 3.5	19.0 ~ 25
12	44 ~ 61	4.5 ~ 6.2	33 ~ 45
14	73 ~ 98	7.4 ~ 10.0	54 ~ 72
16	115 ~ 155	11.5 ~ 16.0	83 ~ 115
18	165 ~ 225	17.0 ~ 23.0	125 ~ 165
20	225 ~ 325	23.0 ~ 33.0	165 ~ 240

Specifications

Item	Standard	Service Limit
Fuel System (DFI)		
Throttle Grip Free Play	2 ~ 3 mm (0.08 ~ 0.12 in.)	- - -
Idle Speed	1 100 ±50 r/min (rpm)	- - -
Bypass Screws (Turn Out)	2 1/2 (for reference)	- - -
Throttle Body Vacuum	40.7 ±1.3 kPa (305 ±10 mmHg) at idle speed	- - -
Air Cleaner Element	Viscous paper element	- - -
Cooling System		
Coolant:		
Type (Recommended)	Permanent type of antifreeze	- - -
Color	Green	- - -
Mixed Ratio	Soft water 50%, Coolant 50%	- - -
Freezing Point	-35°C (-31°F)	- - -
Total Amount	2.9 L (3.1 US qt)	- - -
Engine Top End		
Valve Clearance:		
Exhaust	0.22 ~ 0.31 mm (0.0087 ~ 0.0122 in.)	- - -
Intake	0.15 ~ 0.24 mm (0.0059 ~ 0.0094 in.)	- - -
Clutch		
Clutch Lever Free Play	2 ~ 3 mm (0.08 ~ 0.12 in.)	- - -
Engine Lubrication System		
Engine Oil:		
Type	API SG, SH, SJ, SL or SM with JASO MA, MA1 or MA2	- - -
Viscosity	SAE 10W-40	- - -
Capacity	3.2 L (3.4 US qt) (when filter is not removed)	- - -
	3.8 L (4.0 US qt) (when filter is removed)	- - -
	4.0 L (4.2 US qt) (when engine is completely dry)	- - -
Wheels/Tires		
Tread Depth:		
Front	3.6 mm (0.14 in.)	1 mm (0.04 in.), (AT, CH, DE) 1.6 mm (0.06 in.)
Rear	5.3 mm (0.21 in.)	Up to 130 km/h (80 mph): 2 mm (0.08 in.), Over 130 km/h (80 mph): 3 mm (0.12 in.)
Air Pressure (when Cold):		
Front	Up to 180 kg (397 lb) load: 250 kPa (2.5 kgf/cm ² , 36 psi)	- - -
Rear	Up to 180 kg (397 lb) load: 290 kPa (2.9 kgf/cm ² , 42 psi)	- - -
Final Drive		
Drive Chain Slack	20 ~ 30 mm (0.8 ~ 1.2 in.)	- - -

2-14 PERIODIC MAINTENANCE

Specifications

Item	Standard	Service Limit
Drive Chain Wear (20-link Length) Standard Chain: Make Type Link	317.5 ~ 318.2 mm (12.50 ~ 12.53 in.) ENUMA EK525ZX 112 Links	319 mm (12.56 in.) - - - - - - - - -
Brakes Brake Fluid: Grade Brake Pad Lining Thickness: Front Rear Brake Light Timing: Front Rear	DOT4 4.0 mm (0.16 in.) 5.0 mm (0.20 in.) Pulled ON ON after about 10 mm (0.39 in.) of pedal travel	- - - 1 mm (0.04 in.) 1 mm (0.04 in.) - - - - - -
Electrical System Spark Plug: Type	NGK CR9EIA-9	- - -

Special Tools

Inside Circlip Pliers:
57001-143

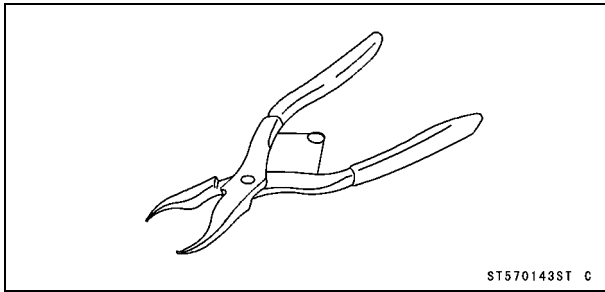

Attachment Jack:
57001-1252

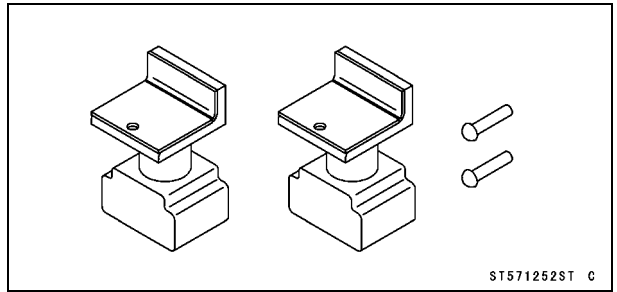

Steering Stem Nut Wrench:
57001-1100

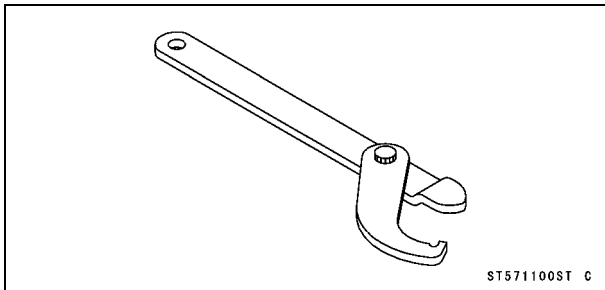

Spark Plug Wrench, Hex 16:
57001-1262

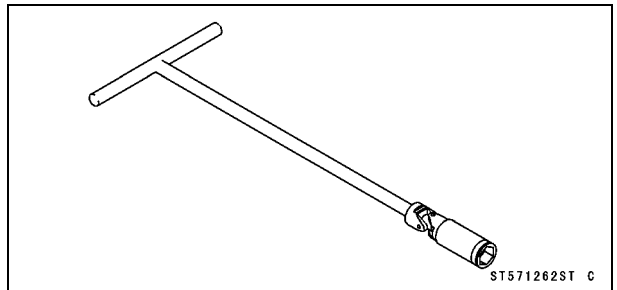

Jack:
57001-1238

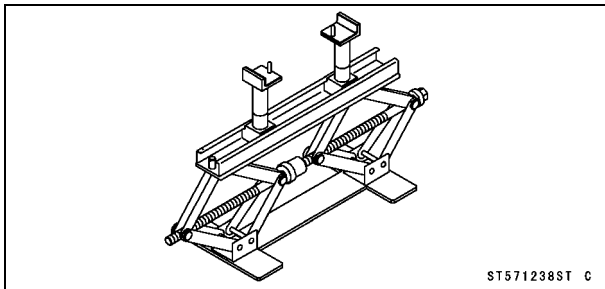

Vacuum Gauge:
57001-1369

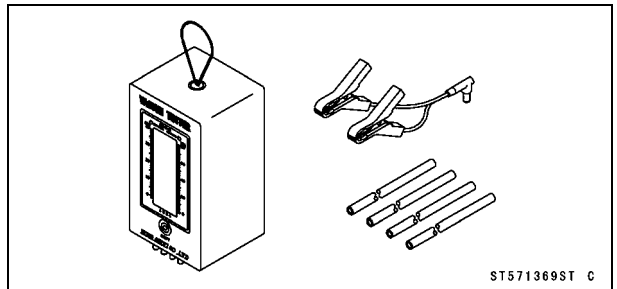

Pilot Screw Adjuster, A:
57001-1239

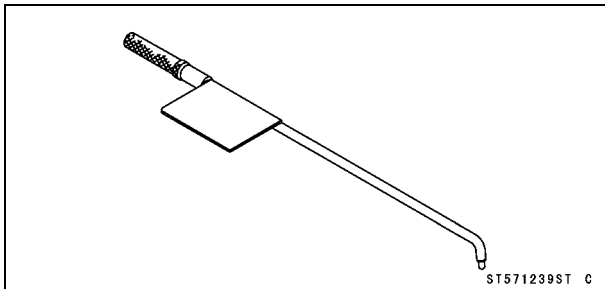

Throttle Sensor Setting Adapter:
57001-1538

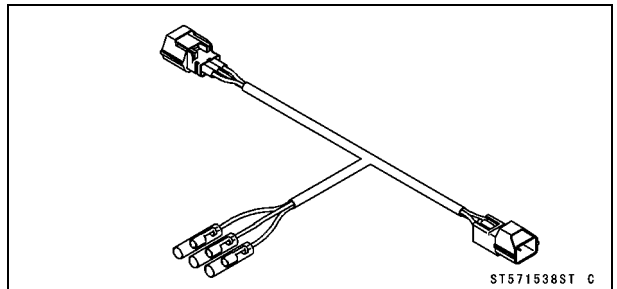

Oil Filter Wrench:
57001-1249

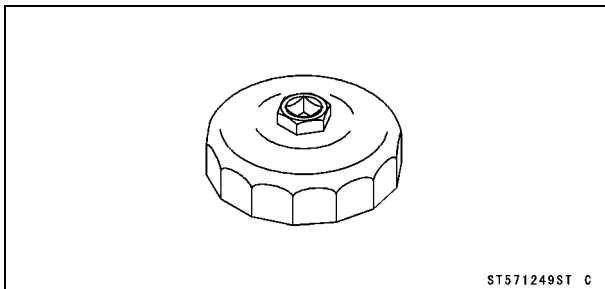

Fuel Hose:
57001-1607

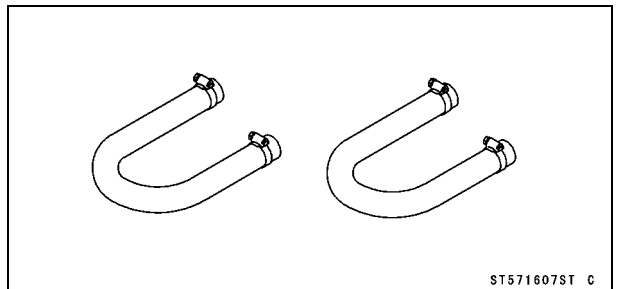

2-16 PERIODIC MAINTENANCE

Special Tools

Jack Attachment:

57001-1608

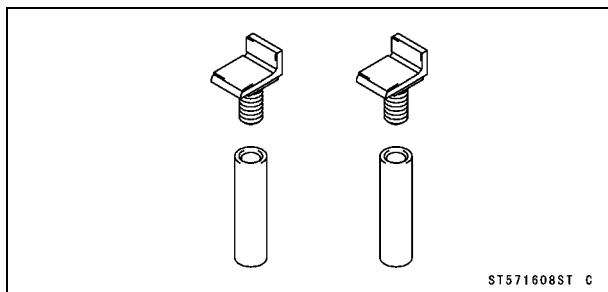

Periodic Maintenance Procedures

Fuel System (DFI)

Throttle Control System Inspection

- Check that the throttle grip [A] moves smoothly from full open to close, and the throttle closes quickly and completely by the return spring in all steering positions.
- ★ If the throttle grip does not return properly, check the throttle cable routing, grip free play, and cable damage. Then lubricate the throttle cable.
- Check the throttle grip free play [B].

Throttle Grip Free Play

Standard: 2 ~ 3 mm (0.08 ~ 0.12 in.)

- ★ If the free play is incorrect, adjust the throttle cable as follows.

- Loosen the locknuts [A] [B].
- Screw both throttle cable adjusters [C] [D] to give the throttle grip plenty of play.
- Turn the decelerator cable adjuster [C] until 2 ~ 3 mm (0.08 ~ 0.12 in.) of throttle grip play is obtained.
- Tighten the locknut [A].
- Turn the accelerator cable adjuster [D] until 2 ~ 3 mm (0.08 ~ 0.12 in.) of throttle grip play is obtained.
- Tighten the locknut [B].
- ★ If the free play can not be adjusted with the adjusters, replace the cable.

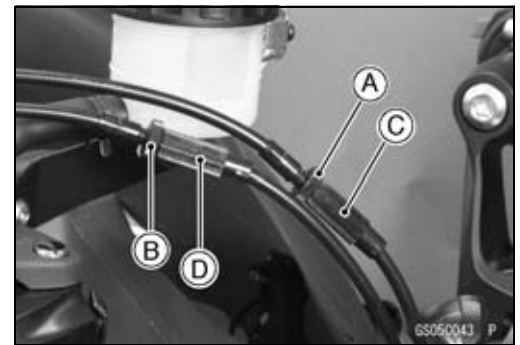
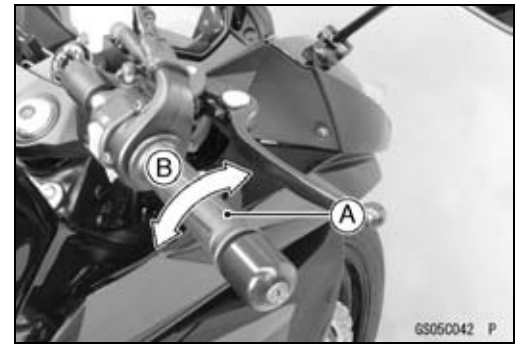

Engine Vacuum Synchronization Inspection

NOTE

○ These procedures are explained on the assumption that the intake and exhaust systems of the engine are in good condition.

- Situate the motorcycle so that it is vertical.
- Remove the air cleaner housing (see Air Cleaner Housing Removal in the Fuel System (DFI) chapter).
- Pull off the rubber caps [A] and vacuum hose [B] from the fittings of each throttle body.
- For the California and Southeast Asia Models, pull off the vacuum hose [A].

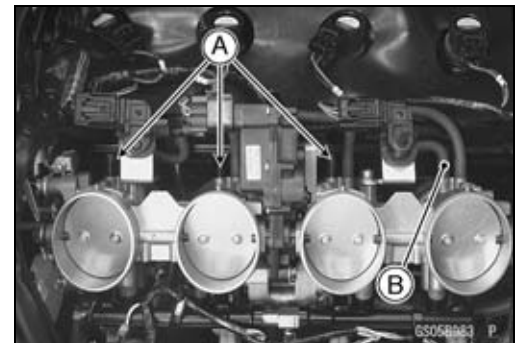

2-18 PERIODIC MAINTENANCE

Periodic Maintenance Procedures

- Plug the vacuum hose end [A].

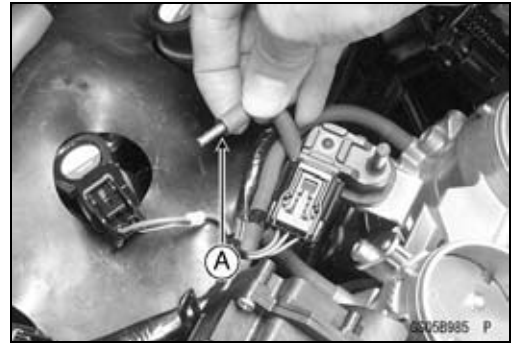

- Connect a vacuum gauge (special tool) and hoses [A] to the fittings on the throttle body.

Special Tool - Vacuum Gauge: 57001-1369

- Connect a highly accurate tachometer [B] to one of the stick coil primary leads.

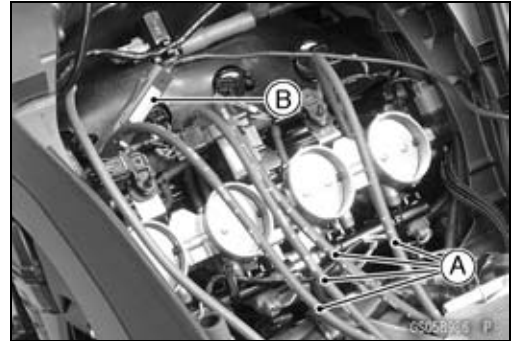

- Plug the air switching valve hose end [A] and air cleaner housing fitting [B].
- Install the air cleaner housing (see Air Cleaner Housing Installation in the Fuel System (DFI) chapter).



- Remove the fuel hose (see Fuel Hose Replacement).
- Connect the following parts temporary.
 - Fuel Pump Lead Connector [A]
 - Fuel Hose [B]

Special Tool - Fuel Hose: 57001-1607

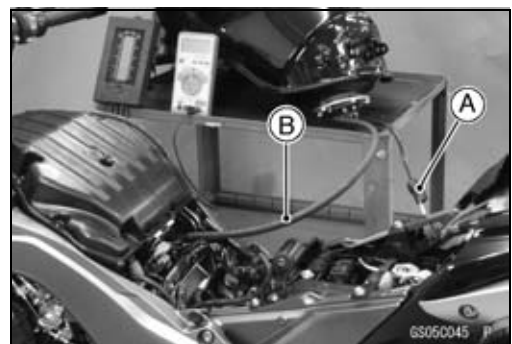

Periodic Maintenance Procedures

- Start the engine and warm it up thoroughly.
- Check the idle speed, using a highly accurate tachometer [A].

Idle Speed

Standard: 1 100 ±50 r/min (rpm)

- ★ If the idle speed is out of the specified range, adjust it with the adjusting screw (see Idle Speed Adjustment).

NOTICE

Do not measure the idle speed by the tachometer of the meter unit.

- While idling the engine, inspect the throttle body vacuum, using the vacuum gauge [B].

Throttle Body Vacuum

Standard: 40.7 ±1.3 kPa (305 ±10 mmHg) at idle speed

- ★ If any vacuum is not within specifications, first synchronize the balance of the left (#1, #2 throttle valves) and right (#3, #4 throttle valves) assemblies.

Example:

- #1: 260 mmHg
- #2: 300 mmHg
- #3: 250 mmHg
- #4: 280 mmHg

- With the engine at the correct idle speed, equalize higher vacuum of #1 or #2 (for example 300 mmHg) to higher vacuum of #3 or #4 (for example 280 mmHg) by turning the center adjusting screw [A].

NOTE

○ After adjustment, the final vacuum measurement between the highest throttle valves may not be 290 mmHg (for example). The goal is to have the highest two vacuums between the left (#1 and #2) and right (#3 and #4) banks be the same.

- Open and close the throttle after each measurement, and adjust the idle speed as necessary.
- Once the throttle valves have been synchronized, inspect output voltage of the main throttle sensor to ensure proper operation (procedure is explained at the end of this section).

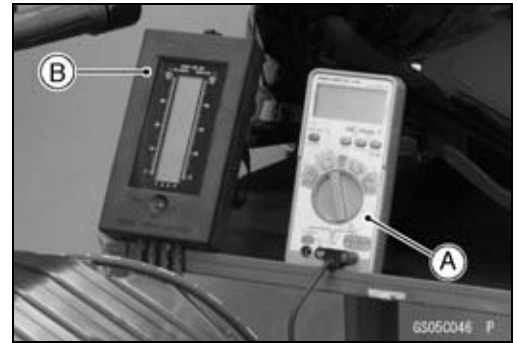

2-20 PERIODIC MAINTENANCE

Periodic Maintenance Procedures

★ If any one vacuum measurement is out of the specified range after left (#1, #2) and right (#2, #3) synchronization, adjust the bypass screws [A].

Special Tool - Pilot Screw Adjuster, A [B]: 57001-1239

- Adjust the lower vacuum between #1 and #2 to the higher vacuum of #1 and #2.
- Adjust the lower vacuum between #3 and #4 to the higher vacuum of #3 and #4.
- Open and close the throttle valves after each measurement, and adjust the idle speed as necessary.
- Check the vacuums as before.
- ★ If all vacuums are within the specification range, finish the engine vacuum synchronization.
- ★ If any vacuum can not be adjusted within the specification, remove the bypass screws #1 ~ #4 and clean them.

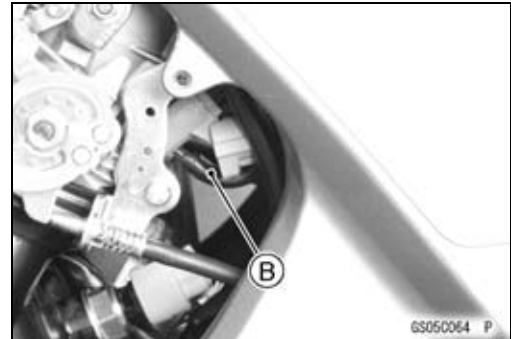
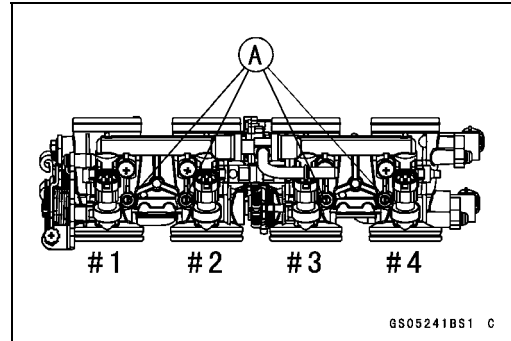

- Turn in the bypass screw [A] with counting the number of turns until it seals fully but not tightly. Record the number of turns.

NOTICE

Do not over tighten them. They could be damaged, requiring replacement.

- Remove:
 - Bypass Screw
 - Spring [B]
 - Washer [C]
 - O-ring [D]
- Check the bypass screw and its hole for carbon deposits.
- ★ If any carbons accumulate, wipe the carbons off from the bypass screw and the hole, using a cotton pad penetrated with a high-flash point solvent.
- Replace the O-ring with a new one.
- Check the tapered portion [E] of the bypass screw for wear or damage.
- ★ If the bypass screw is worn or damaged, replace it.
- Turn in the bypass screw until it seats fully but not tightly.

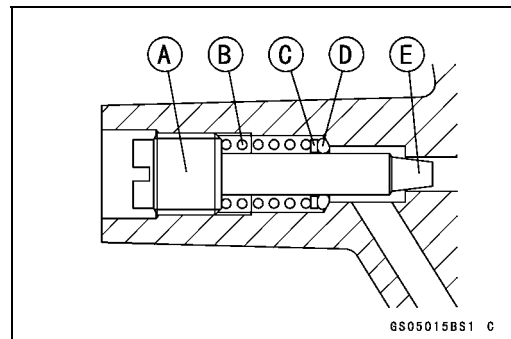

Periodic Maintenance Procedures

- Back out the same number of turns counted when first turned in. This is to set the screw to its original position.

NOTE

○ A throttle body has different “turns out” of the bypass screw for each individual unit. On setting the bypass screw, use the “turns out” determined during disassembly.

- Repeat the same procedure for other bypass screws.
- Repeat the synchronization.
- ★ If the vacuums are correct, check the output voltage of the main throttle sensor (see Main Throttle Sensor Output Voltage Inspection in the Fuel System (DFI) chapter).

Special Tool - Throttle Sensor Setting Adapter: 57001-1538

Main Throttle Sensor Output Voltage

Connections to Adapter:

Digital Meter (+) → W (sensor BL/W) lead

Digital Meter (–) → BK (sensor BR/BK) lead

Standard: DC 0.985 ~ 1.015 V at idle throttle opening

- ★ If the output voltage is out of the standard, check the input voltage of the main throttle sensor (see Main Throttle Sensor Input Voltage Inspection in the Fuel System (DFI) chapter).
- Remove the vacuum gauge hoses and install the rubber caps on the original position.
- For the California and Southeast Asia Models, install the vacuum hoses.
- Run the vacuum hoses according to Cable, Wire, and Hose Routing section in the Appendix chapter. Refer to the diagram of the evaporative emission control system in the Fuel System (DFI) chapter too.

Idle Speed Inspection

- Start the engine and warm it up thoroughly.
- With the engine idling, turn the handlebar to both sides [A].
- ★ If handlebar movement changes the idle speed, the throttle cables may be improperly adjusted or incorrectly routed or damaged. Be sure to correct any of these conditions before riding (see Throttle Control System Inspection and Cable, Wire, and Hose Routing section in the Appendix chapter).



⚠ WARNING

Operation with improperly adjusted, incorrectly routed or damaged cables could result in an unsafe riding condition. Follow the service manual to be make sure to correct any of these conditions.

- Check the idle speed.

Idle Speed

Standard: 1 100 ±50 r/min (rpm)

- ★ If the idle speed is out of the specified range, adjust it.

2-22 PERIODIC MAINTENANCE

Periodic Maintenance Procedures

Idle Speed Adjustment

- Start the engine and warm it up thoroughly.
- Turn the adjusting screw [A] until the idle speed is correct.
- Open and close the throttle a few times to make sure that the idle speed is within the specified range. Readjust if necessary.



Fuel Hose Inspection (fuel leak, damage, installation condition)

- If the motorcycle is not properly handled, the high pressure inside the fuel line can cause fuel to leak [A] or the hose to burst. Support the fuel tank with a suitable bar (see Fuel Hose Replacement) and check the fuel hoses.
- ★ Replace the hose if any fraying, cracks [B] or bulges [C] are noticed.

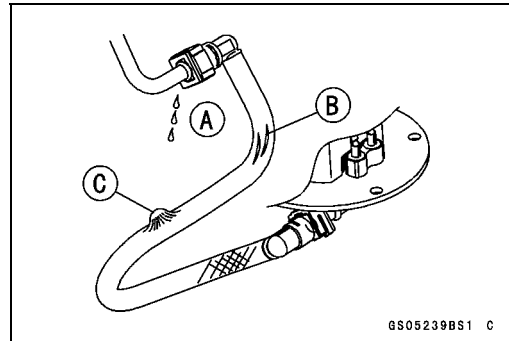

- Check that the hoses are routed according to Cable, Wire, and Hose Routing section in the Appendix chapter.
 - ★ Replace the hose if it has been sharply bent or kinked.
- Hose Joints [A]
Fuel Hose [B]

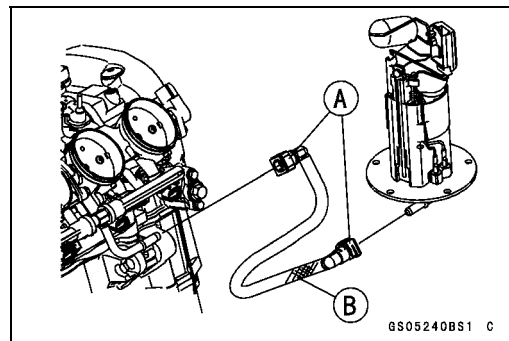

- Check that the hose joints are securely connected.
 - Push and pull [A] the hose joint [B] back and forth more than two times, and make sure it is locked and does not come off.
- Fuel Pump Side [C]
Throttle Body Assy Side [D]

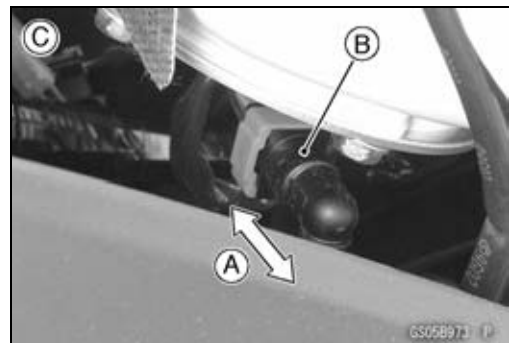

⚠ WARNING

Leaking fuel can cause a fire or explosion resulting in serious burns. Make sure the hose joint is installed correctly on the delivery pipe.

- ★ If it comes off, reinstall the hose joint.

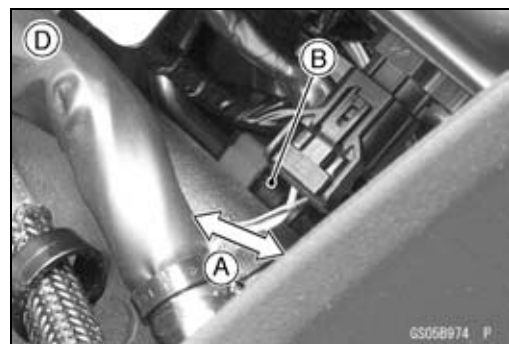

Periodic Maintenance Procedures

Evaporative Emission Control System (CAL and SEA-B1 Models) Inspection

- Inspect the canister as follows.
 - Remove the front seat (see Front Seat Removal in the Frame chapter).
 - Remove the canister [A], and disconnect the hoses from the canister.
 - Visually inspect the canister for cracks or other damage.
 - ★ If the canister has any cracks or bad damage, replace it with a new one.



NOTE

- *The canister is designed to work well through the motorcycle's life without any maintenance if it is used under normal conditions.*

- Check the liquid/vapor separator as follows.
 - Lift up the fuel tank front side, and support the fuel tank with the suitable bar (see Fuel Hose Replacement).
 - Disconnect the hoses from the separator, and remove the separator [A] from the motorcycle right side.
 - Visually inspect the separator for cracks and other damage.
 - ★ If the separator has any cracks or damage, replace it with a new one.
 - To prevent the gasoline from flowing into or out of the canister, hold the separator perpendicular to the ground.
- Check the hoses of the evaporative emission control system as follows.
 - Check that the hoses are securely connected and clips are in position.
 - Replace any kinked, deteriorated or damaged hoses.
 - Run the hoses according to Cable, Wire, and Hose Routing section in the Appendix chapter. Refer to the diagram of the evaporative emission control system in the Fuel System (DFI) chapter too.
 - When installing the hoses, avoid sharp bending, kinking, flattening or twisting, and route the hoses with a minimum of bending so that the emission flow will not be obstructed.

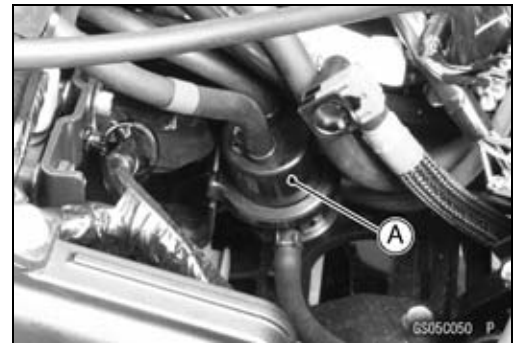

2-24 PERIODIC MAINTENANCE

Periodic Maintenance Procedures

Cooling System

Coolant Level Inspection

NOTE

○ Check the level when the engine is cold (room or ambient temperature).

● Check the coolant level in the reserve tank [A] with the motorcycle held perpendicular (Do not use the side-stand.).

★ If the coolant level is lower than the “L” level line [B], unscrew the reserve tank cap and add coolant to the “F” level line [C].

“L”: low

“F”: full

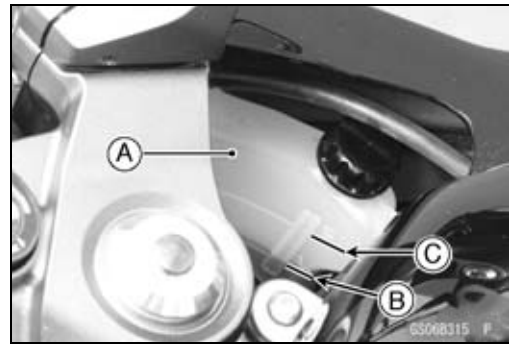

NOTICE

For refilling, add the specified mixture of coolant and soft water. Adding water alone dilutes the coolant and degrades its anticorrosion properties. The diluted coolant can attack the aluminum engine parts. In an emergency, soft water alone can be added. But the diluted coolant must be returned to the correct mixture ratio within a few days.

If coolant must be added often or the reservoir tank has run completely dry, there is probably leakage in the cooling system. Check the system for leaks.

Coolant ruins painted surfaces. Immediately wash away any coolant that spills on the frame, engine, wheels or other painted parts.

Radiator Hose and Pipe Inspection (coolant leak, damage, installation condition)

○ The high pressure inside the radiator hose can cause coolant to leak [A] or the hose to burst if the line is not properly maintained.

● Visually inspect the hoses for signs of deterioration. Squeeze the hoses. A hose should not be hard and brittle, nor should it be soft or swollen.

★ Replace the hose if any fraying, cracks [B] or bulges [C] are noticed.

● Check that the hoses are securely connected and clamps are tightened correctly.

Torque - Radiator (Water) Hose Clamp Screws: 2.9 N·m (0.30 kgf·m, 26 in·lb)

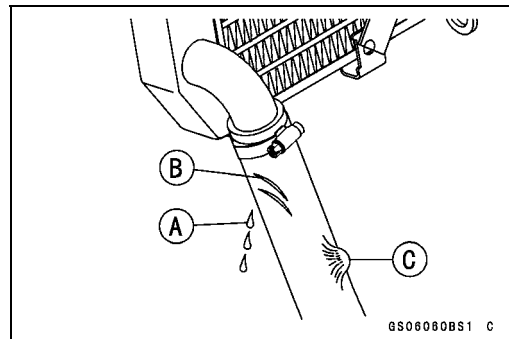

Engine Top End

Valve Clearance Inspection

NOTE

○ Valve clearance must be checked and adjusted when the engine is cold (room temperature).

● Remove:

Crankshaft Sensor Cover (see Crankshaft Sensor Removal in the Electrical System chapter)

Cylinder Head Cover (see Cylinder Head Cover Removal in the Engine Top End chapter)

Periodic Maintenance Procedures

- Turn the crankshaft, align the #1, 4 mark on the timing rotor with the crankcase timing mark.
 TDC Mark [A] for #1, 4 Pistons
 Timing Mark [B] (Crankcase Halves Mating Surface)

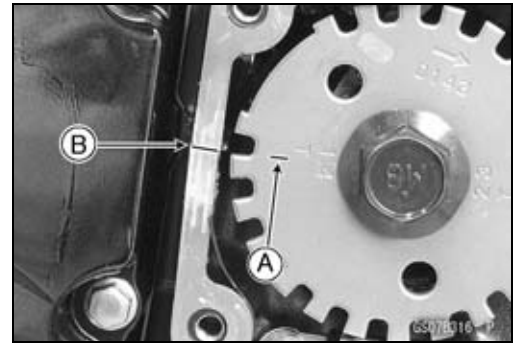

- Using the thickness gauge [A], measure the valve clearance between the cam and the valve lifter.



Valve Clearance

Standard:

Exhaust	0.22 ~ 0.31 mm (0.0087 ~ 0.0122 in.)
Intake	0.15 ~ 0.24 mm (0.0059 ~ 0.0094 in.)

NOTE

- Thickness gauge is horizontally inserted on the valve lifter.

- Appropriateness [A]
- Inadequacy [B]
- Thickness Gauge [C]
- Horizontally Inserts [D]
- Cam [E]
- Valve Lifter [F]
- Hits the Valve Lifter Ahead [G]

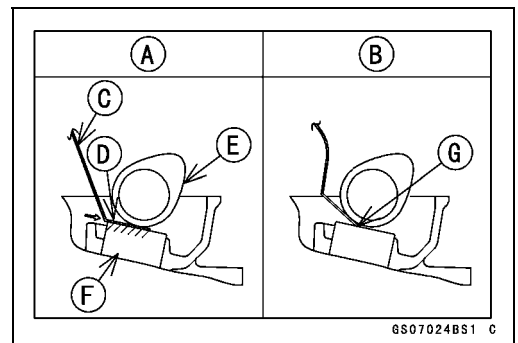

- When positioning #4 piston TDC at the end of the compression stroke:

- Intake Valve Clearance of #2 and #4 Cylinders
- Exhaust Valve Clearance of #3 and #4 Cylinders
- Measuring Valve [A]

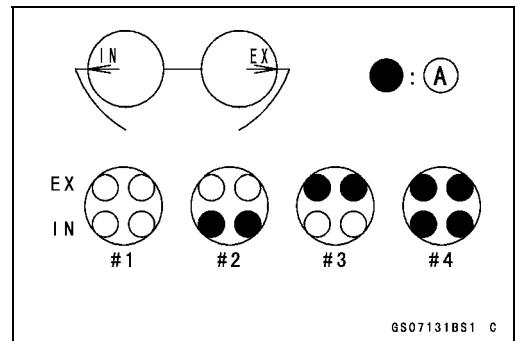

- When positioning #1 piston TDC at the end of the compression stroke:

- Intake Valve Clearance of #1 and #3 Cylinders
- Exhaust Valve Clearance of #1 and #2 Cylinders
- Measuring Valve [A]

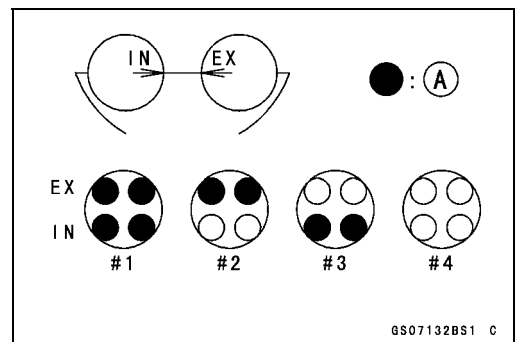

- ★ If the valve clearance is not within the specified range, first record the clearance, and then adjust it.

2-26 PERIODIC MAINTENANCE

Periodic Maintenance Procedures

Valve Clearance Adjustment

- To change the valve clearance, remove the camshaft chain tensioner, camshafts and valve lifters. Replace the shim with one of a different thickness.

NOTE

- Mark and record the locations of the valve lifters and shims so that they can be reinstalled in their original positions.

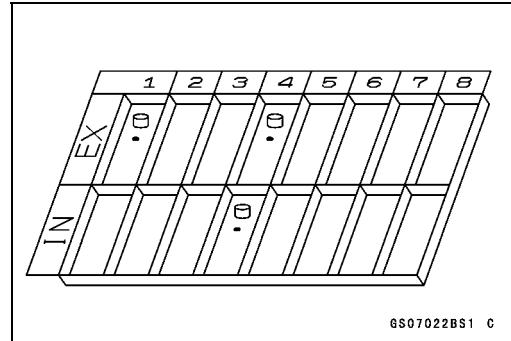

- Besides the standard shims in the valve clearance adjustment charts, the following shims may be installed at the factory. Although they are not available as spare parts, they can be used to adjust valve clearance.

Adjustment Shims

Thickness
3.225 mm
3.275 mm
3.325 mm
2.675 mm
2.725 mm
2.775 mm
2.825 mm
2.875 mm
2.925 mm
2.975 mm
3.025 mm
3.075 mm
3.125 mm
3.175 mm

- Clean the shim to remove any dust or oil.
- Measure the thickness of the removed shim [A].



Periodic Maintenance Procedures

VALVE CLEARANCE ADJUSTMENT CHART INTAKE VALVE

		PRESENT SHIM																			Example		
PART No. (92180-)		1014	1016	1018	1020	1022	1024	1026	1028	1030	1032	1034	1036	1038	1040	1042	1044	1046	1048	1050	1052	1054	
MARK		50	55	60	65	70	75	80	85	90	95	00	05	10	15	20	25	30	35	40	45	50	
THICKNESS (mm)		2.50	2.55	2.60	2.65	2.70	2.75	2.80	2.85	2.90	2.95	3.00	3.05	3.10	3.15	3.20	3.25	3.30	3.35	3.40	3.45	3.50	
VALVE CLEARANCE MEASUREMENT	Example	0.00~0.02	-	-	-	-	2.50	2.55	2.60	2.65	2.70	2.75	2.80	2.85	2.90	2.95	3.00	3.05	3.10	3.15	3.20	3.25	3.30
	0.03~0.07	-	-	-	2.50	2.55	2.60	2.65	2.70	2.75	2.80	2.85	2.90	2.95	3.00	3.05	3.10	3.15	3.20	3.25	3.30	3.35	
	0.08~0.12	-	-	2.50	2.55	2.60	2.65	2.70	2.75	2.80	2.85	2.90	2.95	3.00	3.05	3.10	3.15	3.20	3.25	3.30	3.35	3.40	
	0.13~0.14	-	2.50	2.55	2.60	2.65	2.70	2.75	2.80	2.85	2.90	2.95	3.00	3.05	3.10	3.15	3.20	3.25	3.30	3.35	3.40	3.45	
	0.15~0.24	SPECIFIED CLEARANCE/NO CHANGE REQUIRED																					
	0.25~0.27	2.55	2.60	2.65	2.70	2.75	2.80	2.85	2.90	2.95	3.00	3.05	3.10	3.15	3.20	3.25	3.30	3.35	3.40	3.45	3.50		
	0.28~0.32	2.60	2.65	2.70	2.75	2.80	2.85	2.90	2.95	3.00	3.05	3.10	3.15	3.20	3.25	3.30	3.35	3.40	3.45	3.50			
	0.33~0.37	2.65	2.70	2.75	2.80	2.85	2.90	2.95	3.00	3.05	3.10	3.15	3.20	3.25	3.30	3.35	3.40	3.45	3.50				
	0.38~0.42	2.70	2.75	2.80	2.85	2.90	2.95	3.00	3.05	3.10	3.15	3.20	3.25	3.30	3.35	3.40	3.45	3.50					
	0.43~0.47	2.75	2.80	2.85	2.90	2.95	3.00	3.05	3.10	3.15	3.20	3.25	3.30	3.35	3.40	3.45	3.50						
	0.48~0.52	2.80	2.85	2.90	2.95	3.00	3.05	3.10	3.15	3.20	3.25	3.30	3.35	3.40	3.45	3.50							
	0.53~0.57	2.85	2.90	2.95	3.00	3.05	3.10	3.15	3.20	3.25	3.30	3.35	3.40	3.45	3.50								
	0.58~0.62	2.90	2.95	3.00	3.05	3.10	3.15	3.20	3.25	3.30	3.35	3.40	3.45	3.50									
	0.63~0.67	2.95	3.00	3.05	3.10	3.15	3.20	3.25	3.30	3.35	3.40	3.45	3.50										
	0.68~0.72	3.00	3.05	3.10	3.15	3.20	3.25	3.30	3.35	3.40	3.45	3.50											
	0.73~0.77	3.05	3.10	3.15	3.20	3.25	3.30	3.35	3.40	3.45	3.50												
	0.78~0.82	3.10	3.15	3.20	3.25	3.30	3.35	3.40	3.45	3.50													
	0.83~0.87	3.15	3.20	3.25	3.30	3.35	3.40	3.45	3.50														
	0.88~0.92	3.20	3.25	3.30	3.35	3.40	3.45	3.50															
	0.93~0.97	3.25	3.30	3.35	3.40	3.45	3.50																
0.98~1.02	3.30	3.35	3.40	3.45	3.50																		
1.03~1.07	3.35	3.40	3.45	3.50																			
1.08~1.12	3.40	3.45	3.50																				
1.13~1.17	3.45	3.50																					
1.18~1.22	3.50																						

INSTALL THE SHIM OF THIS THICKNESS (mm)

GS07122BW3 G

1. Measure the clearance (when engine is cold).
2. Check present shim size.
3. Match clearance in vertical column with present shim size in horizontal column.
4. Install the shim specified where the lines intersect. This shim will give the proper clearance.

Example: Present shim is **2.95 mm**
 Measured clearance is **0.45 mm**
 Replace **2.95 mm** shim with **3.20 mm** shim.

5. Remeasure the valve clearance and readjust if necessary.

2-28 PERIODIC MAINTENANCE

Periodic Maintenance Procedures

VALVE CLEARANCE ADJUSTMENT CHART EXHAUST VALVE

		PRESENT SHIM															Example						
PART No. (92180-)		1014	1016	1018	1020	1022	1024	1026	1028	1030	1032	1034	1036	1038	1040	1042	1044	1046	1048	1050	1052	1054	
MARK		50	55	60	65	70	75	80	85	90	95	00	05	10	15	20	25	30	35	40	45	50	
THICKNESS (mm)		2.50	2.55	2.60	2.65	2.70	2.75	2.80	2.85	2.90	2.95	3.00	3.05	3.10	3.15	3.20	3.25	3.30	3.35	3.40	3.45	3.50	
VALVE CLEARANCE MEASUREMENT	Example	0.00~0.04	-	-	-	-	2.50	2.55	2.60	2.65	2.70	2.75	2.80	2.85	2.90	2.95	3.00	3.05	3.10	3.15	3.20	3.25	
	0.05~0.09	-	-	-	-	2.50	2.55	2.60	2.65	2.70	2.75	2.80	2.85	2.90	2.95	3.00	3.05	3.10	3.15	3.20	3.25	3.30	
	0.10~0.14	-	-	-	2.50	2.55	2.60	2.65	2.70	2.75	2.80	2.85	2.90	2.95	3.00	3.05	3.10	3.15	3.20	3.25	3.30	3.35	
	0.15~0.19	-	-	2.50	2.55	2.60	2.65	2.70	2.75	2.80	2.85	2.90	2.95	3.00	3.05	3.10	3.15	3.20	3.25	3.30	3.35	3.40	
	0.20~0.21	-	2.50	2.55	2.60	2.65	2.70	2.75	2.80	2.85	2.90	2.95	3.00	3.05	3.10	3.15	3.20	3.25	3.30	3.35	3.40	3.45	
	0.22~0.31	SPECIFIED CLEARANCE/NO CHANGE REQUIRED																					
	0.32~0.34	2.55	2.60	2.65	2.70	2.75	2.80	2.85	2.90	2.95	3.00	3.05	3.10	3.15	3.20	3.25	3.30	3.35	3.40	3.45	3.50		
	0.35~0.39	2.60	2.65	2.70	2.75	2.80	2.85	2.90	2.95	3.00	3.05	3.10	3.15	3.20	3.25	3.30	3.35	3.40	3.45	3.50			
	0.40~0.44	2.65	2.70	2.75	2.80	2.85	2.90	2.95	3.00	3.05	3.10	3.15	3.20	3.25	3.30	3.35	3.40	3.45	3.50				
	0.45~0.49	2.70	2.75	2.80	2.85	2.90	2.95	3.00	3.05	3.10	3.15	3.20	3.25	3.30	3.35	3.40	3.45	3.50					
	0.50~0.54	2.75	2.80	2.85	2.90	2.95	3.00	3.05	3.10	3.15	3.20	3.25	3.30	3.35	3.40	3.45	3.50						
	0.55~0.59	2.80	2.85	2.90	2.95	3.00	3.05	3.10	3.15	3.20	3.25	3.30	3.35	3.40	3.45	3.50							
	0.60~0.64	2.85	2.90	2.95	3.00	3.05	3.10	3.15	3.20	3.25	3.30	3.35	3.40	3.45	3.50								
	0.65~0.69	2.90	2.95	3.00	3.05	3.10	3.15	3.20	3.25	3.30	3.35	3.40	3.45	3.50									
	0.70~0.74	2.95	3.00	3.05	3.10	3.15	3.20	3.25	3.30	3.35	3.40	3.45	3.50										
	0.75~0.79	3.00	3.05	3.10	3.15	3.20	3.25	3.30	3.35	3.40	3.45	3.50											
	0.80~0.84	3.05	3.10	3.15	3.20	3.25	3.30	3.35	3.40	3.45	3.50												
	0.85~0.89	3.10	3.15	3.20	3.25	3.30	3.35	3.40	3.45	3.50													
	0.90~0.94	3.15	3.20	3.25	3.30	3.35	3.40	3.45	3.50														
	0.95~0.99	3.20	3.25	3.30	3.35	3.40	3.45	3.50															
	1.00~1.04	3.25	3.30	3.35	3.40	3.45	3.50																
	1.05~1.09	3.30	3.35	3.40	3.45	3.50																	
	1.10~1.14	3.35	3.40	3.45	3.50																		
	1.15~1.19	3.40	3.45	3.50																			
	1.20~1.24	3.45	3.50																				
1.25~1.29	3.50																						

INSTALL THE SHIM OF THIS THICKNESS (mm)

GS071208W3 C

1. Measure the clearance (when engine is cold).
2. Check present shim size.
3. Match clearance in vertical column with present shim size in horizontal column.
4. Install the shim specified where the lines intersect. This shim will give the proper clearance.

Example: Present shim is **2.95 mm**.
 Measured clearance is **0.47 mm**.
 Replace **2.95 mm** shim with **3.15 mm** shim.

5. Remeasure the valve clearance and readjust if necessary.

Periodic Maintenance Procedures

NOTICE

Be sure to remeasure the clearance after selecting a shim according to the table. If the clearance is out of the specified range, use the additional shim.

- If there is no valve clearance, use a shim that is a few sizes smaller, and remeasure the valve clearance.
- When installing the shim, face the marked side toward the valve lifter.

NOTICE

Do not put shim stock under the shim. This may cause the shim to pop out at high rpm, causing extensive engine damage.
Do not grind the shim. This may cause it to fracture, causing extensive engine damage.

- Apply engine oil to the valve lifter surface and install the lifter.
- Install the camshaft (see Camshaft Installation in the Engine Top End chapter).
- Recheck the valve clearance and readjust if necessary.
- Install the removed parts (see appropriate chapters).

Air Suction System Damage Inspection

- Pull the air switching valve hose [A] out of the air cleaner housing.
- Start the engine and run it at idle speed.

- Plug [A] the air switching valve hose end with your finger and feel vacuum pulsing in the hose.
- ★ If there is no vacuum pulsation, check the hose line for leak. If there is no leak, check the air switching valve (see Air Switching Valve Unit Test in the Electrical System chapter) or air suction valve (see Air Suction Valve Inspection in the Engine Top End chapter).



2-30 PERIODIC MAINTENANCE

Periodic Maintenance Procedures

Clutch

Clutch Operation Inspection

- Pull the clutch lever just enough to take up the free play [A].
- Measure the gap between the lever and the lever holder.
- ★ If the gap is too wide, the clutch may not release fully. If the gap is too narrow, the clutch may not engage fully. In either case, adjust it.

Clutch Lever Free Play

Standard: 2 ~ 3 mm (0.08 ~ 0.12 in.)

⚠ WARNING

The engine and exhaust system get extremely hot during normal operation and can cause serious burns. Never touch the engine or exhaust pipe during clutch adjustment.

- Turn the adjuster [A] so that 5 ~ 6 mm (0.20 ~ 0.24 in.) [B] of threads are visible.
- Slide the dust cover [A] at the clutch cable lower end out of place.
- Loosen both adjusting nuts [B] at the clutch cover as far as they will go.
- Pull the clutch outer cable [C] tight and tighten the adjusting nuts against the clutch cover [D].
- Slip the dust cover back onto place.
- Turn the adjuster at the clutch lever until the free play is correct.
- Push the release lever [A] toward the front of the motorcycle until it becomes hard to turn.
- At this time, the release lever should have the proper angle shown.
60° [B]
- ★ If the angle is wrong, check the clutch and release parts for wear.

⚠ WARNING

Too much cable play can prevent clutch disengagement and cause an accident resulting in serious injury or death. When adjusting the clutch or replacing the cable, be sure the upper end of the clutch outer cable is fully seated in its fitting, or it could slip into place later, creating enough cable play to prevent clutch disengagement.

- After the adjustment, start the engine and check that the clutch does not slip and that it releases properly.

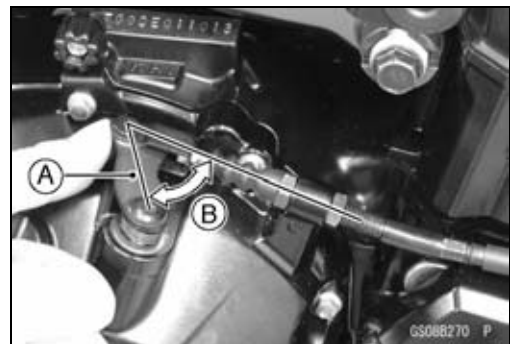
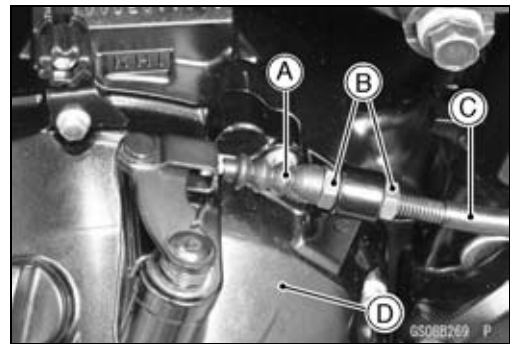
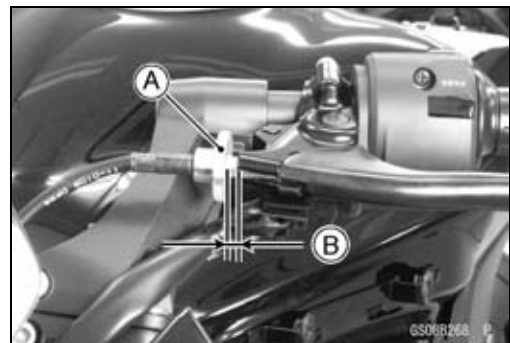
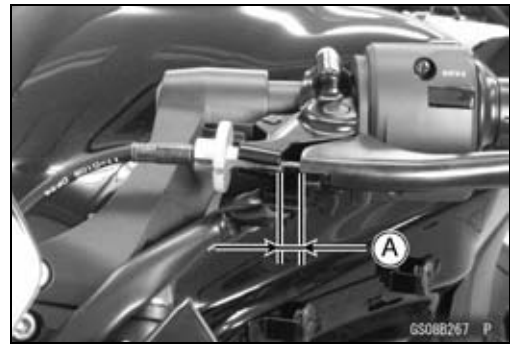

Periodic Maintenance Procedures

Wheels/Tires

Air Pressure Inspection

- Remove the air valve cap.
- Measure the tire air pressure with an air pressure gauge [A] when the tires are cold (that is, when the motorcycle has not been ridden more than a mile during the past 3 hours).
- Install the air valve cap.
- ★ Adjust the tire air pressure according to the specifications if necessary.

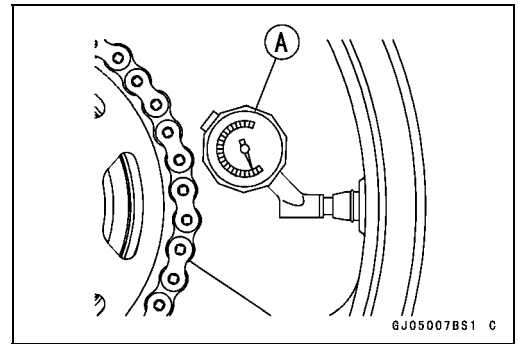

Air Pressure (when Cold)

- Front:** Up to 180 kg (397 lb)
250 kPa (2.5 kgf/cm², 36 psi)
- Rear:** Up to 180 kg (397 lb)
290 kPa (2.9 kgf/cm², 42 psi)

Wheel/Tire Damage Inspection

- Remove any imbedded stones [A] or other foreign particles [B] from tread.
- Visually inspect the tire for cracks and cuts, and replace the tire if necessary. Swelling or high spots indicate internal damage, requiring tire replacement.
- Visually inspect the wheel for cracks, cuts and dents damage.
- ★ If any damage is found, replace the wheel if necessary.

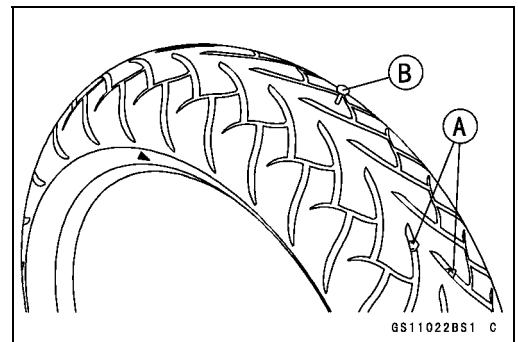

Tire Tread Wear Inspection

As the tire tread wears down, the tire becomes more susceptible to puncture and failure. An accepted estimate is that 90% of all tire failures occur during the last 10% of tread life (90% worn). So it is false economy and unsafe to use the tires until they are bald.

- Measure the tread depth at the center of the tread with a depth gauge [A]. Since the tire may wear unevenly, take measurement at several places.
- ★ If any measurement is less than the service limit, replace the tire (see Tire Removal/Installation in the Wheels/Tires chapter).

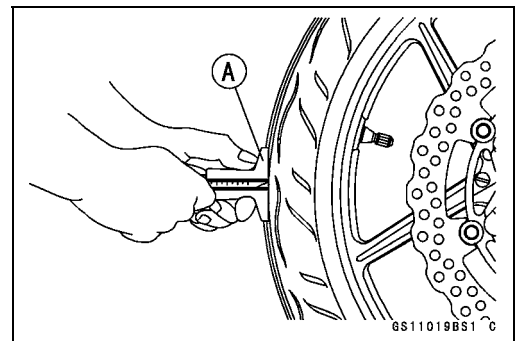

2-32 PERIODIC MAINTENANCE

Periodic Maintenance Procedures

Tread Depth

Standard:

Front 3.6 mm (0.14 in.)

Rear 5.3 mm (0.21 in.)

Service Limit:

Front 1 mm (0.04 in.)

(AT, CH, DE) 1.6 mm (0.06 in.)

Rear 2 mm (0.08 in.)

Up to 130 km/h (80 mph)

3 mm (0.12 in.)

Over 130 km/h (80 mph)

⚠ WARNING

Some replacement tires may adversely affect handling and cause an accident resulting in serious injury or death. To ensure proper handling and stability, use only the recommended standard tires for replacement, inflated to the standard pressure.

NOTE

○Most countries may have their own regulations a minimum tire tread depth: be sure to follow them.

○Check and balance the wheel when a tire is replaced with a new one.

Wheel Bearing Damage Inspection

- Raise the front wheel off the ground with the jack (see Front Wheel Removal in the Wheels/Tires chapter).
 - Turn the handlebar all the way to the right or left.
 - Inspect the roughness of the front wheel bearing by pushing and pulling [A] the wheel.
 - Spin [B] the front wheel lightly, and check for smoothly turn, roughness, binding or noise.
 - ★ If roughness, binding or noise is found, remove the front wheel and inspect the wheel bearing (see Front Wheel Removal, Hub Bearing Inspection in the Wheels/Tires chapter).
-
- Raise the rear wheel off the ground with the stand (see Rear Wheel Removal in the Wheels/Tires chapter).
 - Inspect the roughness of the rear wheel bearing by pushing and pulling [A] the wheel.
 - Spin [B] the rear wheel lightly, and check for smoothly turn, roughness, binding or noise.
 - ★ If roughness, binding or noise is found, remove the rear wheel and inspect the wheel bearing (see Rear Wheel Removal, Hub Bearing Inspection in the Wheels/Tires chapter) and coupling (see Coupling Bearing Inspection in the Final Drive chapter).

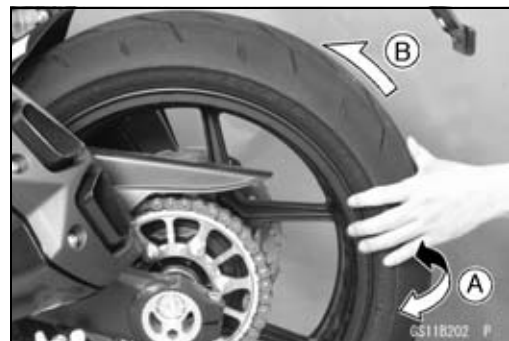
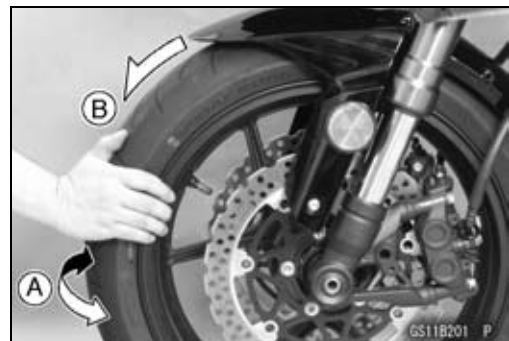

Periodic Maintenance Procedures

Final Drive

Drive Chain Lubrication Condition Inspection

- If a special lubricant is not available, a heavy oil such as SAE 90 is preferred to a lighter oil because it will stay on the chain longer and provide better lubrication.
- If the chain appears especially dirty, clean it before lubrication.

NOTICE

The O-rings between the side plates seal in the lubricant between the pin and the bushing. To avoid damaging the O-rings and resultant loss of lubricant, observe the following rules.

Use only kerosene or diesel oil for cleaning of the O-ring of the drive chain. Any other cleaning solution such as gasoline or trichloroethylene will cause deterioration and swelling of the O-ring. Immediately blow the chain dry with compressed air after cleaning. Complete cleaning and drying the chain within 10 minutes.

- Apply oil to the sides of the rollers so that oil will penetrate to the rollers and bushings. Apply the oil to the O-rings so that the O-rings will be coated with oil.
- Wipe off any excess oil.
 - Oil Applied Areas [A]
 - O-rings [B]

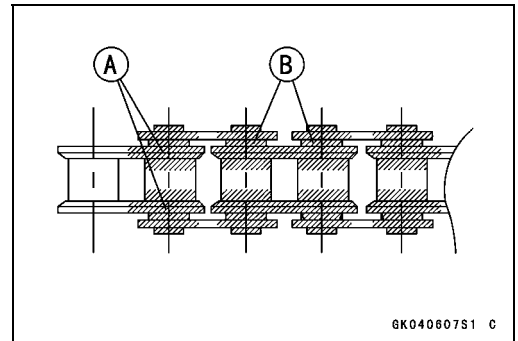

Drive Chain Slack Inspection

NOTE

- Check the slack with the motorcycle setting on its side-stand.
- Clean the chain if it is dirty, and lubricate it if it appears dry.

- Check the wheel alignment (see Wheel Alignment Inspection).
- Rotate the rear wheel to find the position where the chain is tightest.
- Measure the vertical movement (chain slack) [A] midway between the sprockets.
- ★ If the chain slack exceeds the standard, adjust it.

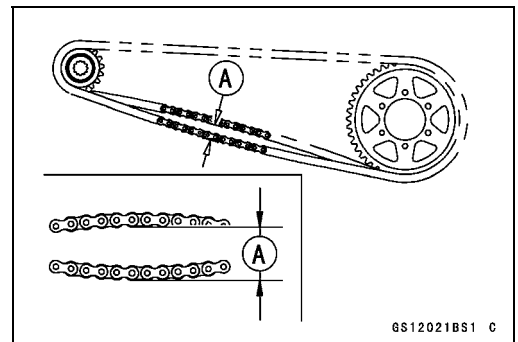

Chain Slack

Standard: 20 ~ 30 mm (0.8 ~ 1.2 in.)

2-34 PERIODIC MAINTENANCE

Periodic Maintenance Procedures

Drive Chain Slack Adjustment

- Loosen the left and right chain adjuster clamp bolts [A].
- Using an Allen wrench [B], turn the adjusters [C] forward or rearward until the drive chain has the correct amount of chain slack.
- Tighten:

Torque - Chain Adjuster Clamp Bolts: 64 N·m (6.5 kgf·m, 47 ft·lb)

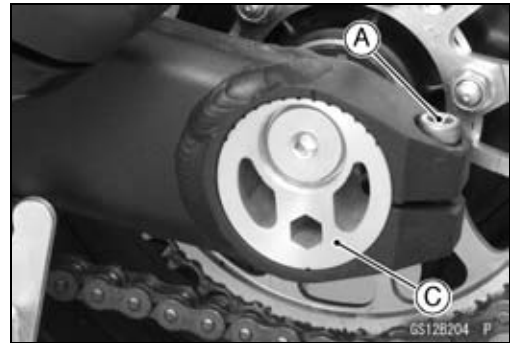

Wheel Alignment Inspection

- Check that the left and right notches [A] the swingarm should point to the same marks or positions [B] on the left and right adjuster.
- ★ If they do not, adjust the chain slack (see Drive Chain Slack Adjustment) and align the wheel alignment.

⚠ WARNING

Misalignment of the wheel will result in abnormal wear and may result in an unsafe riding condition. Be sure the wheel is properly aligned.

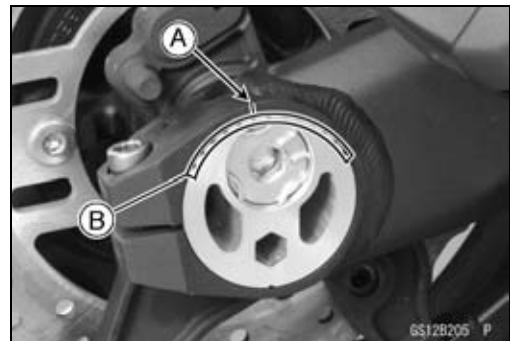

Wheel Alignment Adjustment

- Remove the right retaining ring [A] from the axle shaft.
- Loosen the axle nut [B].
- Loosen the right chain adjuster clamp bolt [C], and turn the right chain adjuster [D] so that the left and right notches on the swingarm may point to the same marks or positions on the left and right adjusters.
- Tighten:

Torque - Chain Adjuster Clamp Bolt: 64 N·m (6.5 kgf·m, 47 ft·lb)

Rear Axle Nut: 98 N·m (10 kgf·m, 72 ft·lb)

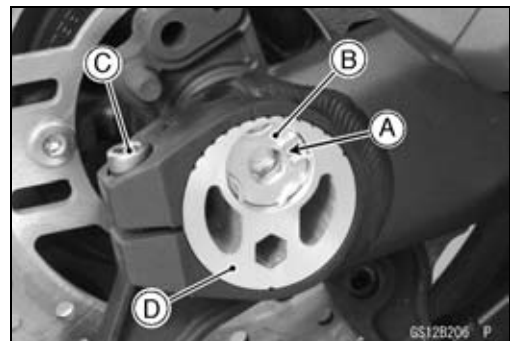

Periodic Maintenance Procedures

Drive Chain Wear Inspection

- Remove the chain cover (see Drive Chain Removal in the Final Drive chapter).
- Rotate the rear wheel to inspect the drive chain for damaged rollers, and loose pins and links.
- ★ If there is any irregularity, replace the drive chain.
- ★ Lubricate the drive chain if it appears dry.
- Stretch the chain taut by hanging a 98 N (10 kg, 20 lb) weight [A] on the chain.
- Measure the length of 20 links [B] on the straight part [C] of the chain from the pin center of the 1st pin to the pin center of the 21st pin. Since the chain may wear unevenly, take measurements at several places.
- ★ If any measurements exceed the service limit, replace the chain. Also, replace the front and rear sprockets when the drive chain is replaced.

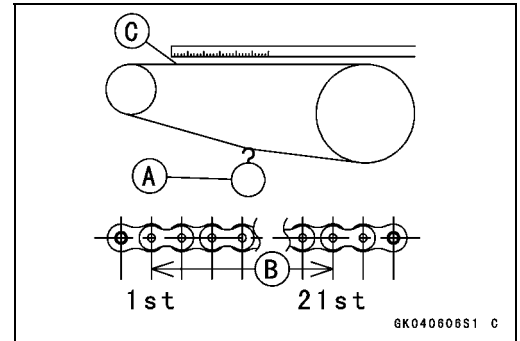

Drive Chain 20-link Length

Standard: 317.5 ~ 318.2 mm (12.50 ~ 12.53 in.)

Service Limit: 319 mm (12.56 in.)

⚠ WARNING

A chain that breaks or jumps off the sprockets could snag on the engine sprocket or lock the rear wheel, severely damaging the motorcycle and causing it to go out of control. Inspect the chain for damage and proper adjustment before each ride. If chain wear exceeds the service limit, replace it with the standard chain.

Standard Chain

Make: ENUMA

Type: EK525ZX

Link: 112 Links

Chain Guide Wear Inspection

- Remove the swingarm (see Swingarm Removal in the Suspension chapter).
- Visually inspect the chain guide [A].
- ★ Replace the chain guide if it shows any signs of abnormal wear or damage.

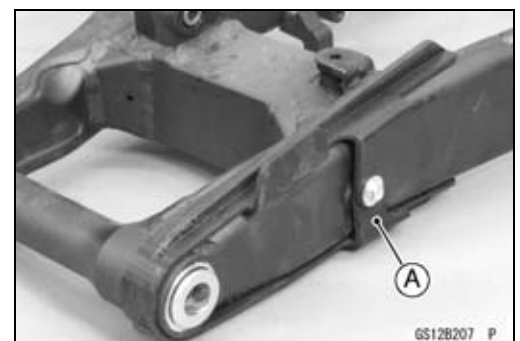

2-36 PERIODIC MAINTENANCE

Periodic Maintenance Procedures

Brakes

Brake Fluid Leak (Brake Hose and Pipe) Inspection

- For ABS equipped models, remove the fuel tank (see Fuel Tank Removal in the Fuel System (DFI) chapter).
- Apply the brake lever or pedal and inspect the brake fluid leak from the brake hoses [A], pipes (ABS equipped models) [B] and fittings [C].
- ★ If the brake fluid leaked from any position, inspect or replace the problem part.

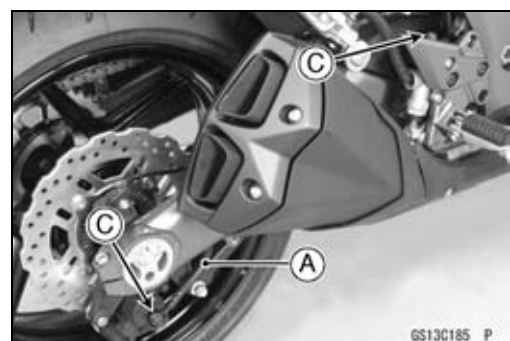
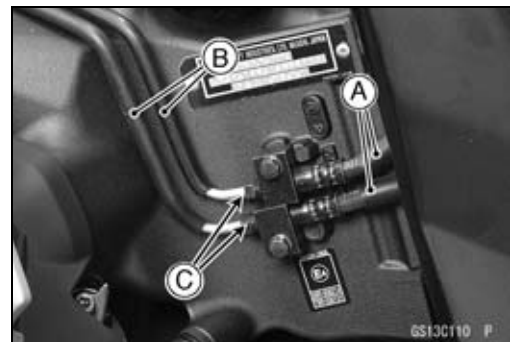
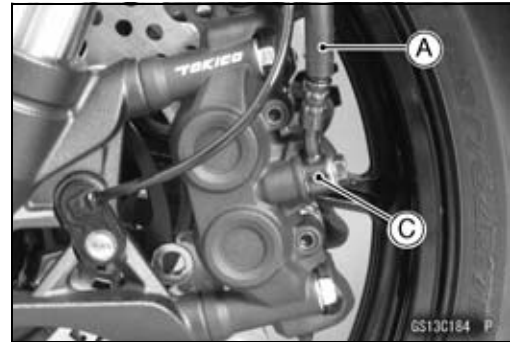
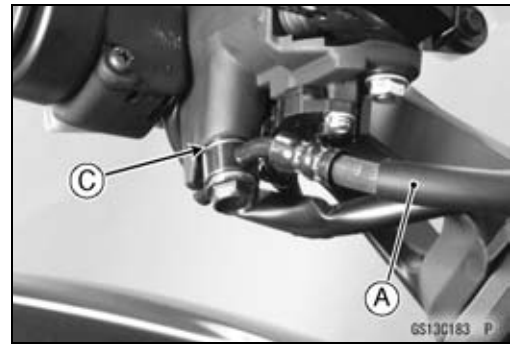

Periodic Maintenance Procedures

Brake Hose and Pipe Damage and Installation Condition Inspection

- For ABS equipped models, remove the fuel tank (see Fuel Tank Removal in the Fuel System (DFI) chapter).
- Inspect the brake hoses and fittings for deterioration, cracks and signs of leakage.
- The high pressure inside the brake line can cause fluid to leak [A] or the hose, pipe (ABS equipped models) to burst if the line is not properly maintained. Bend and twist the rubber hose while examining it.
- ★ Replace the hose and pipe (ABS equipped models) if any crack [B], bulge [C] or leakage is noticed.
- ★ Tighten any brake hose banjo bolts and brake pipe joint nuts.

Torque - Brake Hose Banjo Bolts: 25 N·m (2.5 kgf·m, 18 ft·lb)

**Brake Pipe Joint Nuts: 18 N·m (1.8 kgf·m, 13 ft·lb)
(ABS Equipped Models)**

- Inspect the brake hose routing.
- ★ If any brake hose routing is incorrect, route the brake hose according to Cable, Wire, and Hose Routing section in the Appendix chapter.

Brake Operation Inspection

- Inspect the operation of the front and rear brake by running the vehicle on the dry road.
- ★ If the brake operation is insufficiency, inspect the brake system.

⚠ WARNING
When test riding the vehicle, be aware of surrounding traffic for your safety.

Brake Fluid Level Inspection

- Check that the brake fluid level in the front brake reservoir [A] is above the lower level line [B].

NOTE

○ Hold the reservoir horizontal by turning the handlebar when checking brake fluid level.

- ★ If the fluid level is lower than the lower level line, fill the reservoir to the upper level line [C].
- Remove the stopper [D].
- Tighten:

Torque - Front Master Cylinder Reservoir Cap Stopper Screw: 1.2 N·m (0.12 kgf·m, 11 in·lb)

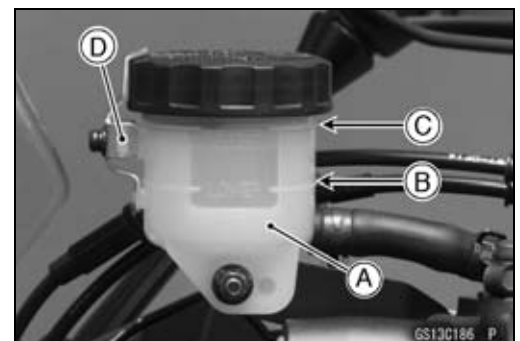
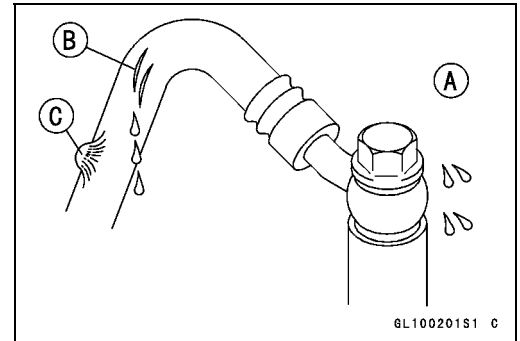

2-38 PERIODIC MAINTENANCE

Periodic Maintenance Procedures

- Check that the brake fluid level in the rear brake reservoir [A] is above the lower level line [B].
- ★ If the fluid level is lower than the lower level line, fill the reservoir to the upper level line [C].
- Remove the stopper [D].

⚠ WARNING

Mixing brands and types of brake fluid can reduce the brake system's effectiveness and cause an accident resulting in injury or death. Do not mix two brands of brake fluid. Change the brake fluid in the brake line completely if the brake fluid must be re-filled but the type and brand of the brake fluid that is already in the reservoir are unidentified.

Recommended Disc Brake Fluid

Grade: DOT4

- Follow procedure below to install the front/rear brake fluid reservoir cap correctly.
- First, tighten the rear brake fluid reservoir cap [B] clockwise [C] by hand until slight resistance is felt indicating that the cap is seated on the reservoir body, then tighten the cap an additional 1/6 turn [D] while holding the brake fluid reservoir body [A].

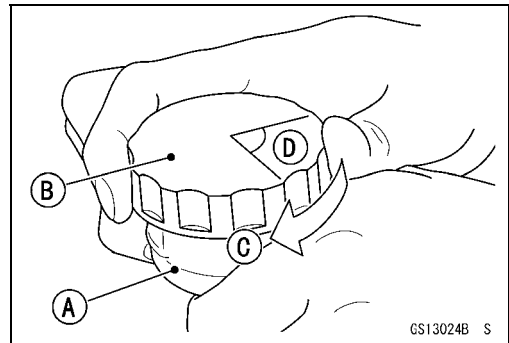
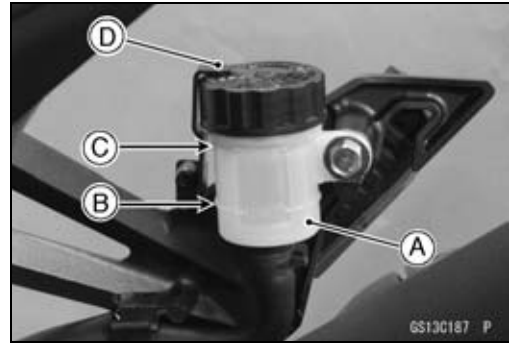

Brake Pad Wear Inspection

- Remove the brake pads (see Front/Rear Brake Pad Removal in the Brakes chapter).
- Check the lining thickness [A] of the pads in each caliper.
- ★ If the lining thickness of either pad is less than the service limit [B], replace both pads in the caliper as a set.
 - [C] Front Brake Pad
 - [D] Rear Brake Pad

Pad Lining Thickness

Standard:

Front 4.0 mm (0.16 in.)

Rear 5.0 mm (0.20 in.)

Service Limit: 1 mm (0.04 in.)

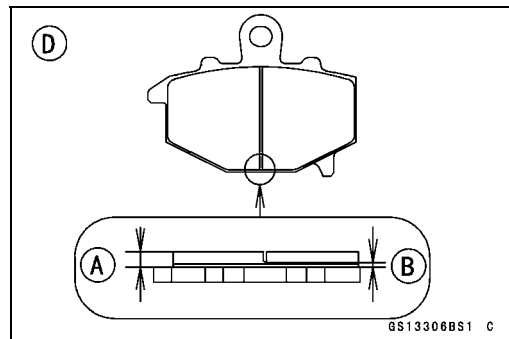
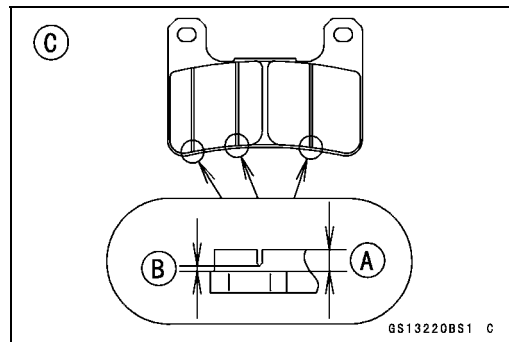

Periodic Maintenance Procedures

Brake Light Switch Operation Inspection

- Turn on the ignition switch.
- The brake light [A] should go on when the brake lever is applied or after the brake pedal is depressed about 10 mm (0.39 in.).



★ If it does not, adjust the brake light switch as follows.

- Remove:
 - Rear Lower Fairing (see Rear Lower Fairing Removal in the Frame chapter)
 - Rear Master Cylinder Mounting Bolts [A]
 - Footpeg Bracket Bolts [B]
 - Footpeg Bracket [C]

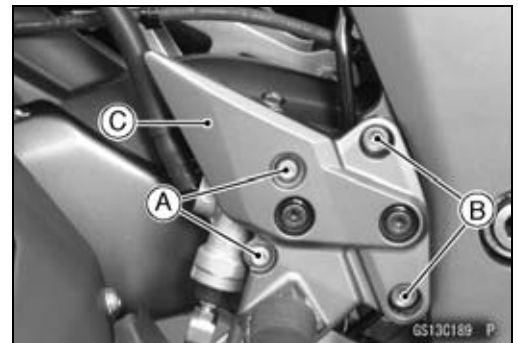

- While holding the switch body, turn the adjusting nut to adjust the switch.
 - Switch Body [A]
 - Adjusting Nut [B]
 - Light sooner as the body rises [C]
 - Light later as the body lowers [D]

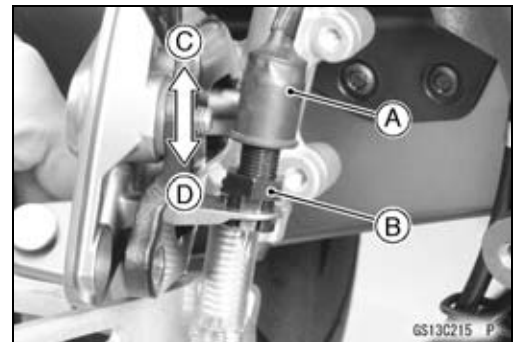

NOTICE

To avoid damaging the electrical connections inside the switch, be sure that the switch body does not turn during adjustment.

- ★ If it does not go on, inspect or replace the following items.
 - Battery (see Charging Condition Inspection in the Electrical System chapter)
 - Brake Light (see Tail/Brake Light Removal in the Electrical System chapter)
 - Main Fuse 30 A and Taillight Fuse 10 A (see Fuse Inspection in the Electrical System chapter)
 - Front Brake Light Switch [A] (see Switch Inspection in the Electrical System chapter)
 - Rear Brake Light Switch (see Switch Inspection in the Electrical System chapter)
 - Harness (see Wiring Inspection in the Electrical System chapter)

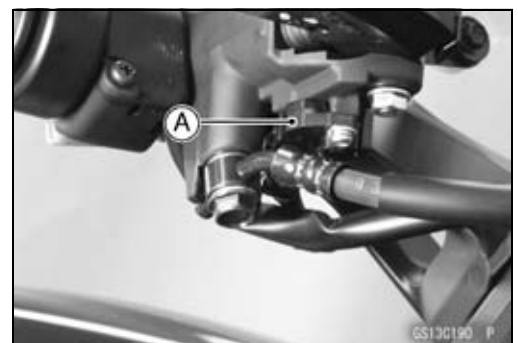

- Tighten:
 - Torque - Front Footpeg Bracket Bolt: 25 N·m (2.5 kgf·m, 18 ft·lb)**
 - Rear Master Cylinder Mounting Bolts: 25 N·m (2.5 kgf·m, 18 ft·lb)**

2-40 PERIODIC MAINTENANCE

Periodic Maintenance Procedures

Suspension

Front Forks/Rear Shock Absorber Operation Inspection

- Pump the forks down and up [A] 4 or 5 times, and inspect the smooth stroke.
- ★ If the forks do not smoothly or noise is found, inspect the fork oil level or fork clamps (see Front Fork Oil Change in the Suspension chapter).



- Pump the seat down and up [A] 4 or 5 times, and inspect the smooth stroke.
- ★ If the shock absorber does not smoothly stroke or noise is found, inspect the oil leak (see Rear Shock Absorber Oil Leak Inspection).

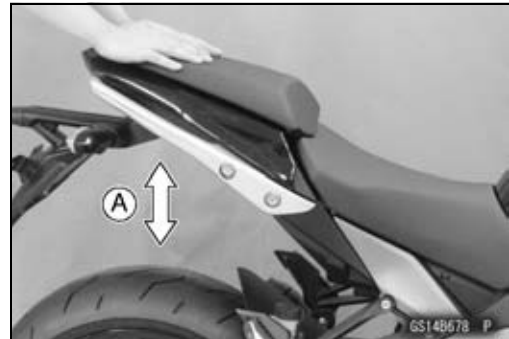

Front Fork Oil Leak Inspection

- Visually inspect the front forks [A] for oil leakage.
- ★ Replace or repair any defective parts, if necessary.

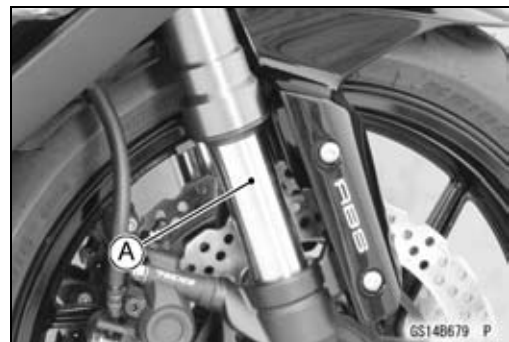

Rear Shock Absorber Oil Leak Inspection

- Visually inspect the shock absorber [A] for oil leakage.
- ★ If the oil leakage is found on it, replace the shock absorber with a new one.



Rocker Arm Operation Inspection

- Pump the seat down and up 4 or 5 times, and inspect the smooth stroke.
- ★ If the rocker arms [A] do not smoothly stroke or noise is found, inspect the fasteners and bearings (see Rocker Arm/Tie-Rod Bearing, Sleeve Inspection in the Suspension chapter).

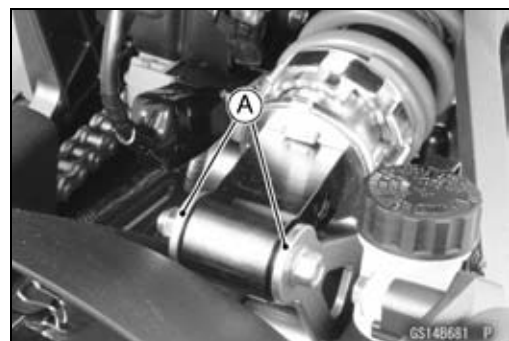

Periodic Maintenance Procedures

Tie-Rod Operation Inspection

- Pump the seat down and up 4 or 5 times, and inspect the smooth stroke.
- ★ If the tie-rod [A] does not smoothly stroke or noise is found, inspect the fasteners and tie-rod bearings (see Rocker Arm/Tie-Rod Bearing, Sleeve Inspection in the Suspension chapter).

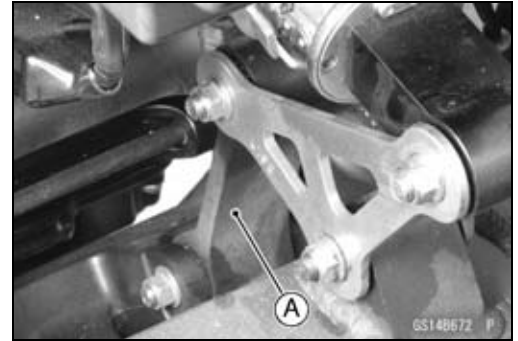

Steering

Steering Play Inspection

- Remove the lower fairing (see Lower Fairing Removal in the Frame chapter).
- Raise the front wheel off the ground with the jack (see Front Wheel Removal in the Wheels/Tires chapter).
- With the front wheel pointing straight ahead, alternately tap each end of the handlebar. The front wheel should swing fully left and right from the force of gravity until the fork hits the stop.
- ★ If the wheel binds or catches before the stop, the steering is too tight.
- Feel for steering looseness by pushing and pulling [A] the forks.
- ★ If you feel looseness, the steering is too loose.

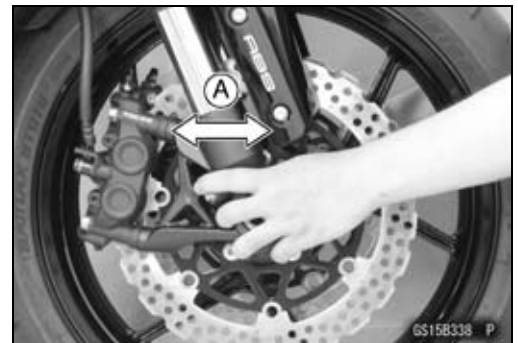

NOTE

- The cables and wiring will have some effect on the motion of the fork which must be taken into account.
- Be sure the leads and cables are properly routed.
- The bearings must be in good condition and properly lubricated in order for any test to be valid.

Steering Play Adjustment

- Remove:
 - Upper Fairing Bracket (see Upper Fairing Bracket Removal in the Frame chapter)
 - Handlebar (see Handlebar Removal in the Steering chapter)
 - Steering Stem Head Bolt Plug [A]
 - Steering Stem Head Bolt [B]
 - Upper Front Fork Clamp Bolts [C] (Loosen)
 - Stem Head [D]

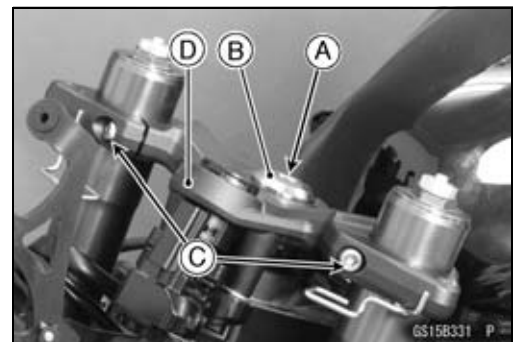

2-42 PERIODIC MAINTENANCE

Periodic Maintenance Procedures

- Bend the claws [A] of the claw washer back.
- Remove the steering stem locknut [B] and claw washer [C].

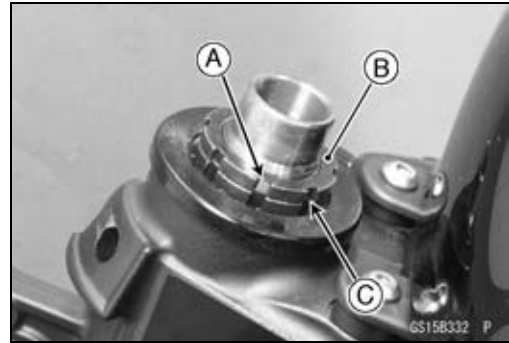

- Adjust the steering.

Special Tool - Steering Stem Nut Wrench [A]: 57001-1100

- ★ If the steering is too tight, loosen the stem nut a fraction of a turn.
- ★ If the steering is too loose, tighten the stem nut a fraction of a turn.

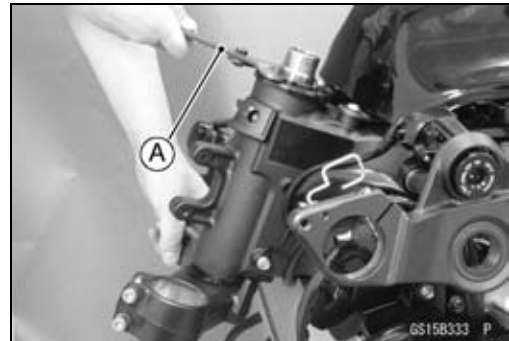

NOTE

○ Turn the stem nut 1/8 turn at time maximum.

- Install the claw washer [A] so that its bent side [B] faces upward, and engage the bent claws with the grooves of stem locknut [C].
- Hand tighten the stem locknut until the claw washer touches the steering stem nut.
- Tighten the stem locknut clockwise until the claws are aligned with the grooves (ranging from 2nd to 4th) of stem nut [D], and bend the 2 claws downward [E].
- Install the stem head.
- Tighten:

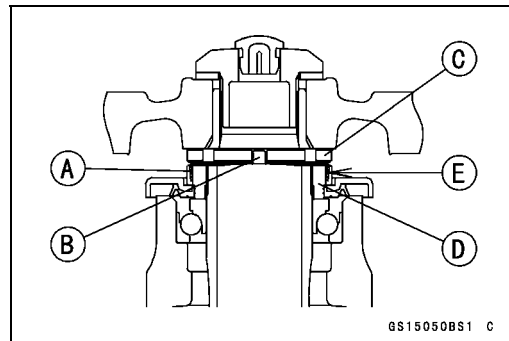

Torque - Steering Stem Head Bolt: 108 N·m (11.0 kgf·m, 79.7 ft·lb)

Upper Front Fork Clamp Bolts: 20 N·m (2.0 kgf·m, 15 ft·lb)

- Check the steering again.
- ★ If the steering is still too tight or too loose, repeat the adjustment.
- Install the removed parts (see appropriate chapters).

Periodic Maintenance Procedures

Steering Stem Bearing Lubrication

- Remove the steering stem (see Stem, Stem Bearing Removal in the Steering chapter).
- Using a high-flash point solvent, wash the upper and lower ball bearings in the cages, and wipe the upper and lower outer races, which are press-fitted into the frame head pipe, clean off grease and dirt.
- Visually check the outer races and the ball bearings.
- ★ Replace the bearing assemblies if they show wear or damage.
- Pack the upper and lower ball bearings [A] in the cages with grease, and apply a light coat of grease to the upper and lower outer races.
- Install the steering stem (see Stem, Stem Bearing Installation in the Steering chapter).
- Adjust the steering (see Steering Play Adjustment).

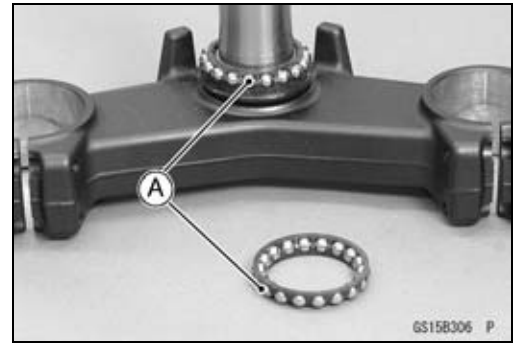

2-44 PERIODIC MAINTENANCE

Periodic Maintenance Procedures

Electrical System

Lights and Switches Operation Inspection

First Step

- Turn on the ignition switch.
- The following lights should go on according to below table.

City Lights [A]	goes on
Taillight [B]	goes on
License Plate Light [C]	goes on
Meter Panel LCD [D]	goes on
Neutral Indicator Light (LED) [E]	goes on
Warning Symbol and Warning Indicator Light (LED) [F]	goes on
ABS Indicator Light (LED) [G] (ABS Equipped Models)	goes on

- ★ If the light does not go on, inspect or replace the following item.

Battery (see Charging Condition Inspection in the Electrical System chapter)

Main Fuse 30 A and Taillight Fuse 10 A (see Fuse Inspection in the Electrical System chapter)

Applicable Bulb (see Wiring Diagram in the Electrical System chapter)

Meter Unit for Meter Panel LCD (see Electronic Combination Meter Unit Inspection in the Electrical System chapter)

Meter Unit for Neutral Indicator Light (LED) (see Meter Unit Inspection in the Electrical System chapter)

Meter Unit for Warning Indicator Light (LED) (see Meter Unit Inspection in the Electrical System chapter)

ECU (see ECU Power Supply Inspection in the Fuel System (DFI) chapter)

Ignition Switch (see Switch Inspection in the Electrical System chapter)

Neutral Switch (see Switch Inspection in the Electrical System chapter)

Harness (see Wiring Inspection in the Electrical System chapter)

ABS Indicator Light (LED) (ABS Equipped Models) (see ABS Indicator Light (LED) Inspection in the Brakes chapter)

- Turn off the ignition switch.
- The all lights should go off.
- ★ If the light does not go off, replace the ignition switch.

Second Step

- Turn the ignition switch to P (Park) position.
- The city light, taillight and license plate light should go on.
- ★ If the light does not go on, inspect or replace the following item.
 - Ignition Switch (see Switch Inspection in the Electrical System chapter)

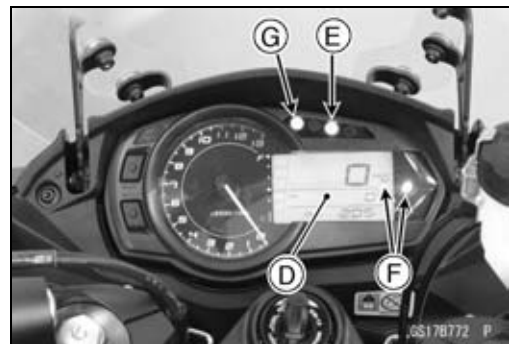
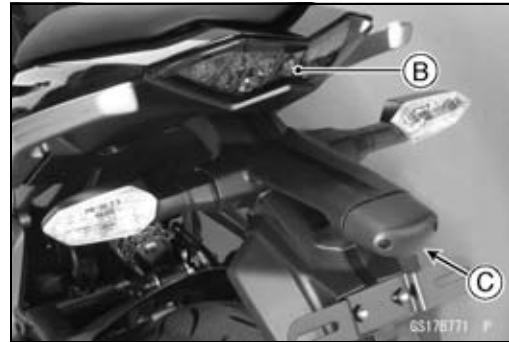

Periodic Maintenance Procedures

Third Step

- Turn on the turn signal switch [A] (left or right position).
- The left or right turn signal lights [B] (front and rear) according to the switch position should flash.
- The turn signal indicator light (LED) [C] in the meter unit should flash.

★ If the each light does not flash, inspect or replace the following item.

Turn Signal Light Bulb (see Turn Signal Light Bulb Replacement in the Electrical System chapter)

Meter Unit for Turn Signal Indicator Light (LED) (see Meter Unit Inspection in the Electrical System chapter)

Turn Signal Relay Fuse 10 A (see Fuse Inspection in the Electrical System chapter)

Turn Signal Switch (see Switch Inspection in the Electrical System chapter)

Turn Signal Relay (see Turn Signal Relay Inspection in the Electrical System chapter)

Harness (see Wiring Inspection in the Electrical System chapter)

- Push the turn signal switch.
- The turn signal lights and indicator light (LED) should go off.

★ If the light does not go off, inspect or replace the following item.

Turn Signal Switch (see Switch Inspection in the Electrical System chapter)

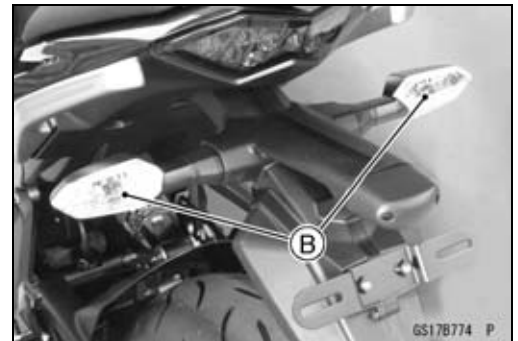

Fourth Step

- Set the dimmer switch [A] to low beam position.
- Start the engine.
- The low beam headlight should go on.

★ If the low beam headlight does not go on, inspect or replace the following item.

Headlight Low Beam Bulb (see Headlight Bulb Replacement in the Electrical System chapter)

Headlight Fuse 10 A (see Fuse Inspection in the Electrical System chapter)

Dimmer Switch (see Switch Inspection in the Electrical System chapter)

Headlight Relay in Relay Box (see Relay Circuit Inspection in the Electrical System chapter)

Harness (see Wiring Inspection in the Electrical System chapter)

2-46 PERIODIC MAINTENANCE

Periodic Maintenance Procedures

- Set the dimmer switch to high beam position.
- The low beam [A] and high beam [B] headlights should go on.
- The high beam indicator light (LED) [C] should go on.
- ★ If the high beam headlight and/or high beam indicator light (LED) does not go on, inspect or replace the following item.
 - Headlight High Beam Bulb (see Headlight Bulb Replacement in the Electrical System chapter)
 - Meter Unit for High Beam Indicator Light (LED) (see Meter Unit Inspection in the Electrical System chapter)
 - Dimmer Switch (see Switch Inspection in the Electrical System chapter)
- Turn off the engine stop switch.
- The low beam and high beam headlights should stay going on.
- ★ If the headlights and high beam indicator light (LED) does go off, inspect or replace the following item.
 - Headlight Relay in Relay Box (see Relay Circuit Inspection in the Electrical System chapter)
- Turn off the ignition switch.
- The headlights and high beam indicator light (LED) should go off.

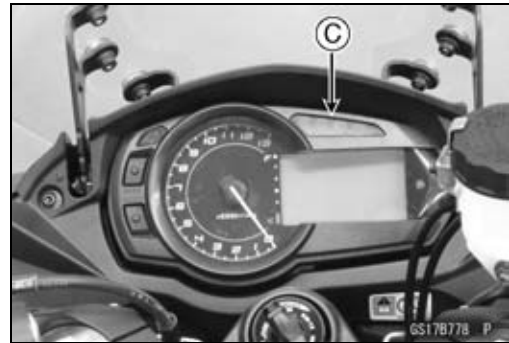
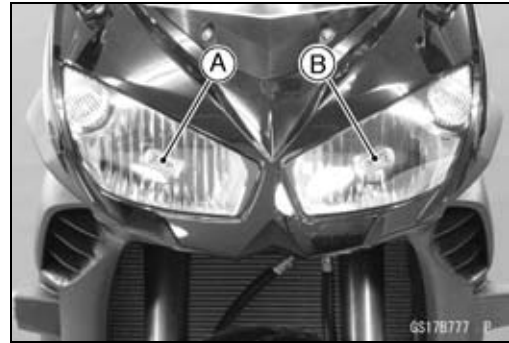

Headlight Aiming Inspection

- Inspect the headlight beam for aiming.
- ★ If the headlight beam is off the point, adjust the headlight aiming.

Headlight Beam Horizontal Adjustment

- Remove the meter cover (see Upper Fairing Removal in the Frame chapter.)
- Turn the horizontal adjuster [A] in both headlights with the screwdriver in or out until the beam points straight ahead.
- ★ If the headlight beam points too low or high, adjust the vertical beam.

Headlight Beam Vertical Adjustment

- Turn the vertical adjuster [B] in both headlights in or out to adjust the headlight vertically.

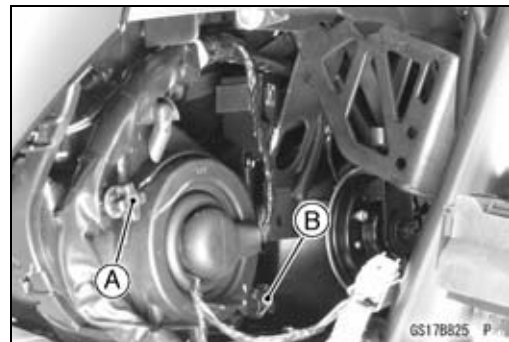

NOTE

- On high beam, the brightest points should be slightly below horizontal with the motorcycle on its wheels and the rider seated. Adjust the headlight to the proper angle according to local regulations.

Periodic Maintenance Procedures

NOTE

○ For US model, the proper angle is 0.4 degrees below horizontal. This is 50 mm (2 in.) drop at 7.6 m (25 ft) measured from the center of the headlight with the motorcycle on its wheels and the rider seated.

50 mm (2 in.) [A]

Center of Brightest Spot [B]

7.6 m (25 ft) [C]

Height of Headlight Center [D]

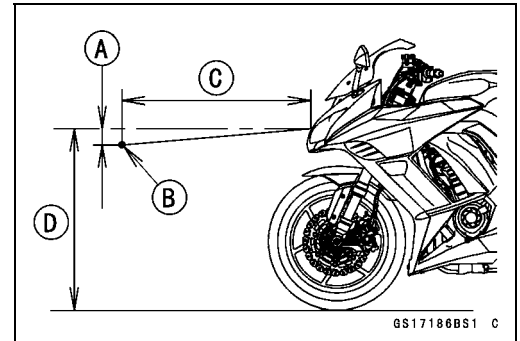

Sidestand Switch Operation Inspection

● Inspect the sidestand switch [A] operation accordance to the following table.

Sidestand Switch Operation

Sidestand	Gear Position	Clutch Lever	Engine Start	Engine Run
Up	Neutral	Released	Starts	Continue running
Up	Neutral	Pulled in	Starts	Continue running
Up	In Gear	Released	Doesn't start	Continue running
Up	In Gear	Pulled in	Starts	Continue running
Down	Neutral	Released	Starts	Continue running
Down	Neutral	Pulled in	Starts	Continue running
Down	In Gear	Released	Doesn't start	Stops
Down	In Gear	Pulled in	Doesn't start	Stops

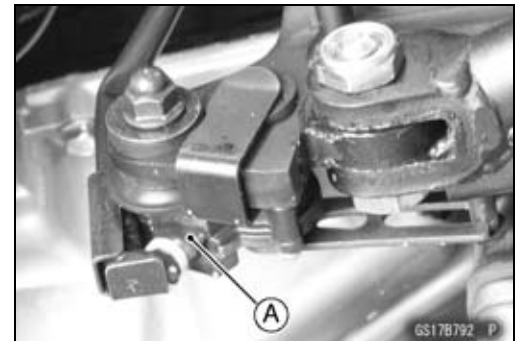

2-48 PERIODIC MAINTENANCE

Periodic Maintenance Procedures

- ★ If the sidestand switch operation does not work, inspect or replace the following item.
 - Battery (see Charging Condition Inspection in the Electrical System chapter)
 - Main Fuse 30 A (see Fuse Inspection in the Electrical System chapter)
 - Ignition Fuse 15 A (see Fuse Inspection in the Electrical System chapter)
 - Ignition Switch (see Switch Inspection in the Electrical System chapter)
 - Sidestand Switch (see Switch Inspection in the Electrical System chapter)
 - Engine Stop Switch (see Switch Inspection in the Electrical System chapter)
 - Starter Button (see Switch Inspection in the Electrical System chapter)
 - Neutral Switch (see Switch Inspection in the Electrical System chapter)
 - Starter Relay (see Starter Relay Inspection in the Electrical System chapter)
 - Relay Box (see Relay Circuit Inspection in the Electrical System chapter)
 - Harness (see Wiring Inspection in the Electrical System chapter)
- ★ If the all parts are good condition, replace the ECU (see ECU Removal/Installation in the Fuel System (DFI) chapter).

Engine Stop Switch Operation Inspection

First Step

- Turn on the ignition switch.
- Set the neutral position.
- Turn the engine stop switch to stop position [A].
- Push the starter button.
- The engine does not start.
- ★ If the engine starts, inspect or replace the following item.
 - Engine Stop Switch (see Switch Inspection in the Electrical System chapter)

Second Step

- Turn on the ignition switch.
- Set the neutral position.
- Turn the engine stop switch to run position [A].
- Push the starter button and run the engine.
- Turn the engine stop switch to stop position.
- Immediately the engine should be stop.
- ★ If the engine does not stop, inspect or replace the following item.
 - Engine Stop Switch (see Switch Inspection in the Electrical System chapter)

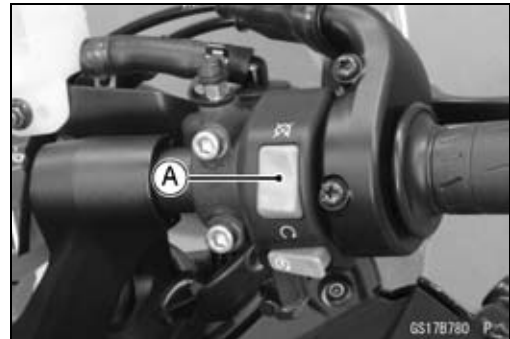

Periodic Maintenance Procedures

Others

Chassis Parts Lubrication

- Before lubricating each part, clean off any rusty spots with rust remover and wipe off any grease, oil, dirt, or grime.
- Lubricate the points listed below with indicated lubricant.

NOTE

○ *Whenever the vehicle has been operated under wet or rainy conditions, or especially after using a high-pressure water spray, perform the general lubrication.*

Pivots: Lubricate with Grease.

- Brake Lever
- Brake Pedal
- Clutch Lever
- Rear Brake Joint Pin
- Sidestand

Points: Lubricate with Grease.

- Clutch Inner Cable Upper and Lower Ends [A]
- Throttle Inner Cable Upper and Lower Ends

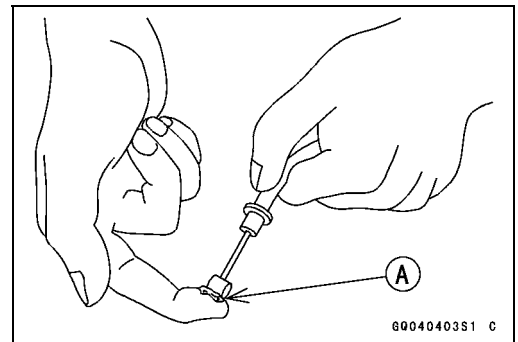

Cables: Lubricate with Rust Inhibitor.

- Clutch Cable
- Throttle Cables

- Lubricate the cables by seeping the oil between the cable and housing.
- The cable may be lubricated by using a commercially available pressure cable lubricator with an aerosol cable lubricant.

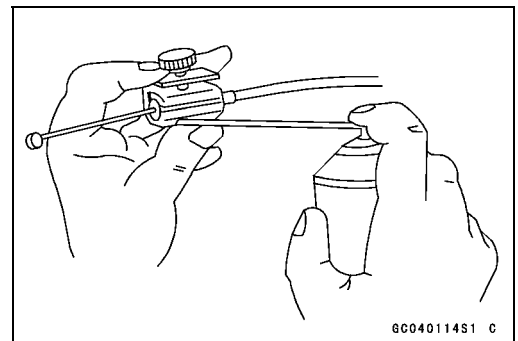

2-50 PERIODIC MAINTENANCE

Periodic Maintenance Procedures

- With the cable disconnected at both ends, the cable should move freely [A] within the cable housing.
- ★ If cable movement is not free after lubricating, if the cable is frayed [B], or if the cable housing is kinked [C], replace the cable.

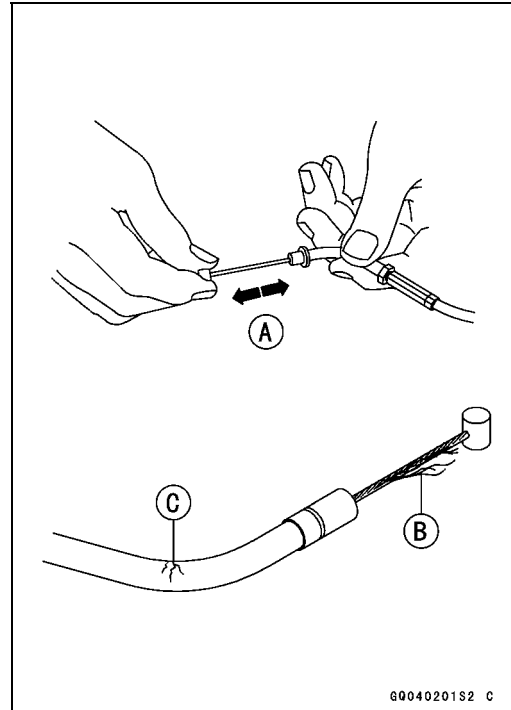

Periodic Maintenance Procedures

Bolts, Nuts and Fasteners Tightness Inspection

- Check the tightness of the bolts and nuts listed here. Also, check to see that each cotter pin is in place and in good condition.

NOTE

○ *For the engine fasteners, check the tightness of them when the engine is cold (at room temperature).*

- ★ If there are loose fasteners, retighten them to the specified torque following the specified tightening sequence. Refer to the appropriate chapter for torque specifications. If torque specifications are not in the appropriate chapter, see the Standard Torque Table. For each fastener, first loosen it by 1/2 turn, then tighten it.
- ★ If cotter pins are removed, replace them with new ones.

Bolt, Nut and Fastener to be checked

Engine:

- Clutch Lever Pivot Bolt Locknut
- Engine Mounting Bolts and Nuts
- Exhaust Pipe Manifold Holder Nuts
- Exhaust Pipe Mounting Bolt
- Muffler Body Clamp Bolts
- Muffler Body Mounting Bolt and Nuts
- Radiator Upper and Lower Bolts
- Subframe Bolts

Wheels:

- Front Axle
- Front Axle Clamp Bolt
- Rear Axle Nut

Brakes:

- Brake Lever Pivot Nut
- Brake Pedal Bolt
- Brake Rod Joint Cotter Pin
- Caliper Mounting Bolts
- Front Master Cylinder Clamp Bolts
- Rear Master Cylinder Mounting Bolts

Suspension:

- Front Fork Clamp Bolts
- Rear Shock Absorber Bolt and Nut
- Swingarm Pivot Shaft Locknut
- Swingarm Pivot Shaft Nut
- Tie-Rod Nuts
- Rocker Arm Nut

Steering:

- Handlebar Holder Bolts
- Steering Stem Head Bolt

Others:

- Footpeg Bracket Bolts
- Front Fender Bolts
- Sidestand Bolt

2-52 PERIODIC MAINTENANCE

Periodic Maintenance Procedures

Replacement Parts

Air Cleaner Element Replacement

NOTE

○ In dusty areas, the element should be replaced more frequently than the recommended interval.

⚠ WARNING

If dirt or dust is allowed to pass through into the throttle body assy, the throttle may become stuck, possibly causing accident. Replace the air cleaner element according to the maintenance chart.

NOTICE

If dirt gets through into the engine, excessive engine wear and possibly engine damage will occur.

- Remove:
 - Fuel Tank (see Fuel Tank Removal in the Fuel System (DFI) chapter)
 - Connector Bracket [A]
 - Screws [B]
 - Upper Air Cleaner Housing [C]



- Discard the air cleaner element [A].



- Install a new element so that flat side faces forward.
- Tighten:
 - Torque - Upper Air Cleaner Housing Screws: 1.1 N·m (0.11 kgf·m, 9.7 in·lb)

Fuel Hose Replacement

- Remove the fuel tank (see Fuel Tank Removal in the Fuel System (DFI) chapter).

Periodic Maintenance Procedures

- Be sure to place a piece of cloth [A] around the fuel hose joint.
- Insert a thin blade screwdriver [B] into the slit [C] on the joint lock [D].
- Turn the driver to disconnect the joint lock.

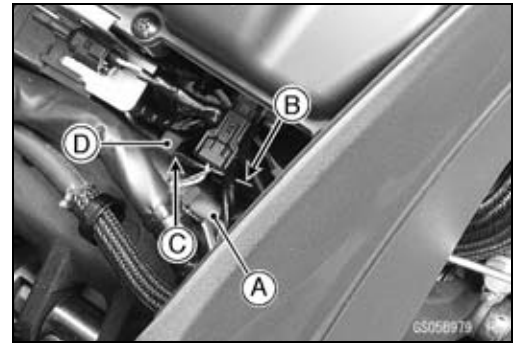

- Pull the fuel hose joint [A] out of the delivery pipe.

⚠ WARNING

Fuel is flammable and explosive under certain conditions and can cause severe burns. Be prepared for fuel spillage; any spilled fuel must be completely wiped up immediately. When the fuel hose is disconnected, fuel spills out from the hose and the pipe. Cover the hose connection with a clean shop towel to prevent fuel spillage.



- Replace the fuel hose with a new one.
- Run the fuel hose correctly (see Cable, Wire, and Hose Routing section in the Appendix chapter).
- Insert the fuel hose joint [A] straight onto the delivery pipe until the hose joint clicks.
- Push [B] the joint lock [C].

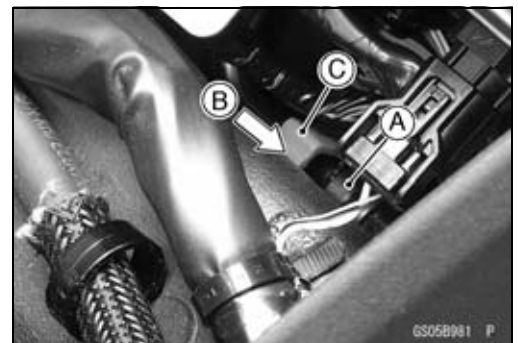

- Push and pull [A] the fuel hose joint [B] back and forth more than two times and make sure it is locked and does not come off.

⚠ WARNING

Leaking fuel can cause a fire or explosion resulting in severe burns. Make sure the fuel hose joint is installed correctly on the delivery pipe and that it doesn't leak.

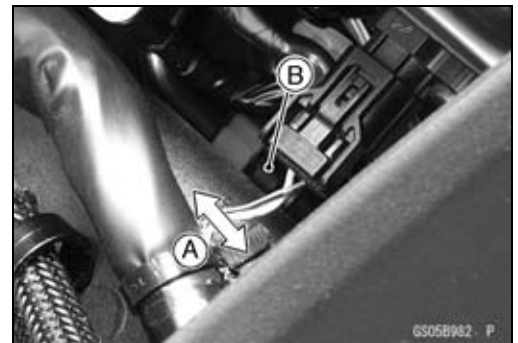

★ If it comes off, reinstall the hose joint.

- Run the fuel hose correctly (see Cable, Wire, and Hose Routing section in the Appendix chapter).
- Install the fuel tank (see Fuel Tank Installation in the Fuel System (DFI) chapter).
- Start the engine and check the fuel hose for leaks.

2-54 PERIODIC MAINTENANCE

Periodic Maintenance Procedures

Coolant Change

⚠ WARNING

Coolant can be extremely hot and cause severe burns, is toxic and very slippery. Do not remove the radiator cap or attempt to change the coolant when the engine is hot; allow it cool completely. Immediately wipe any spilled coolant from tires, frame, engine or other painted parts. Do not ingest coolant.

- Remove the left lower fairing (see Lower Fairing Removal in the Frame chapter).
- Place a container under the coolant drain bolt [A], then remove the drain bolt.



- Remove the right center fairing (see Center Fairing Removal in the Frame chapter).
- Remove the radiator cap [A] in two steps. First turn the cap counterclockwise to the first stop. Then push and turn it further in the same direction and remove the cap.
- The coolant will drain from the radiator and engine.



- Remove:
 - Right Lower Fairing Assembly (see Lower Fairing Assembly Removal in the Frame chapter)
 - Hose [A]
 - Reserve Tank Bolts [B]
- Turn over the reserve tank, remove the cap, and pour the coolant into a suitable container.
- Install the reserve tank.
- Replace the drain bolt gasket with a new one.
- Tighten the drain bolt with the gasket.

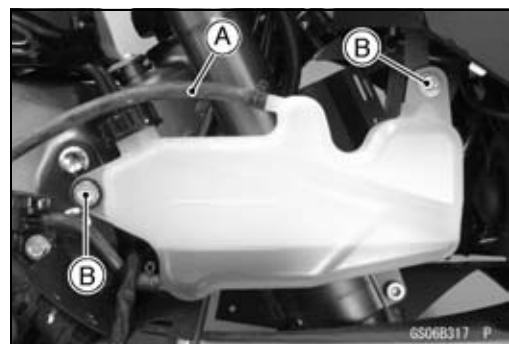

Torque - Coolant Drain Bolt: 11 N·m (1.1 kgf·m, 97 in·lb)

Periodic Maintenance Procedures

- When filling the coolant, choose a suitable mixture ratio by referring to the coolant manufacturer's directions.

NOTICE

Soft or distilled water must be used with the antifreeze in the cooling system. If hard water is used in the system, it causes scales accumulation in the water passages, and considerably reduces the efficiency of the cooling system.

Water and Coolant Mixture Ratio (Recommended)

- Soft Water: 50%**
- Coolant: 50%**
- Freezing Point: -35°C (-31°F)**
- Total Amount: 2.9 L (3.1 US qt)**

- Fill the radiator up to the filler neck [A] with coolant.

NOTE

○ Pour in the coolant slowly so that it can expel the air from the engine and radiator.

- Check the cooling system for leaks.
- Tap the radiator hoses to force any air bubbles caught inside.
- Fill the radiator up to the filler neck with coolant.

- Fill the reserve tank up to the "F" (full) level line [A] with coolant and install the cap [B].
- Start the engine, warm it up thoroughly until the radiator fan turns on and then stop the engine.
- Check the coolant level in the reserve tank after the engine cools down.
- ★ If the coolant level is lower than the "L" (low) level line [C], add coolant to the "F" level line.

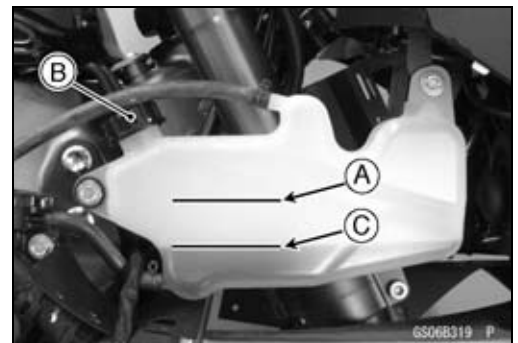

NOTICE

Do not add more coolant above the "F" level line.

2-56 PERIODIC MAINTENANCE

Periodic Maintenance Procedures

Radiator Hose and O-ring Replacement

- Drain the coolant (see Coolant Change).
- Remove:
 - Thermostat Housing [A] (see Thermostat Removal in the Cooling System chapter)
 - Water Pump Cover [B] (see Water Pump Removal in the Cooling System chapter)
 - Oil Cooler [C] (see Oil Cooler Removal in the Engine Lubrication System chapter)
- Replace the hoses [D] and O-rings [E] with new ones.
- Apply grease to the O-rings and install them.
- Install the hoses and tighten the clamps securely.

**Torque - Radiator (Water) Hose Clamp Screws: 2.9 N·m
(0.30 kgf·m, 26 in·lb)**

- Fill the coolant (see Coolant Change).
- Check the cooling system for leaks.

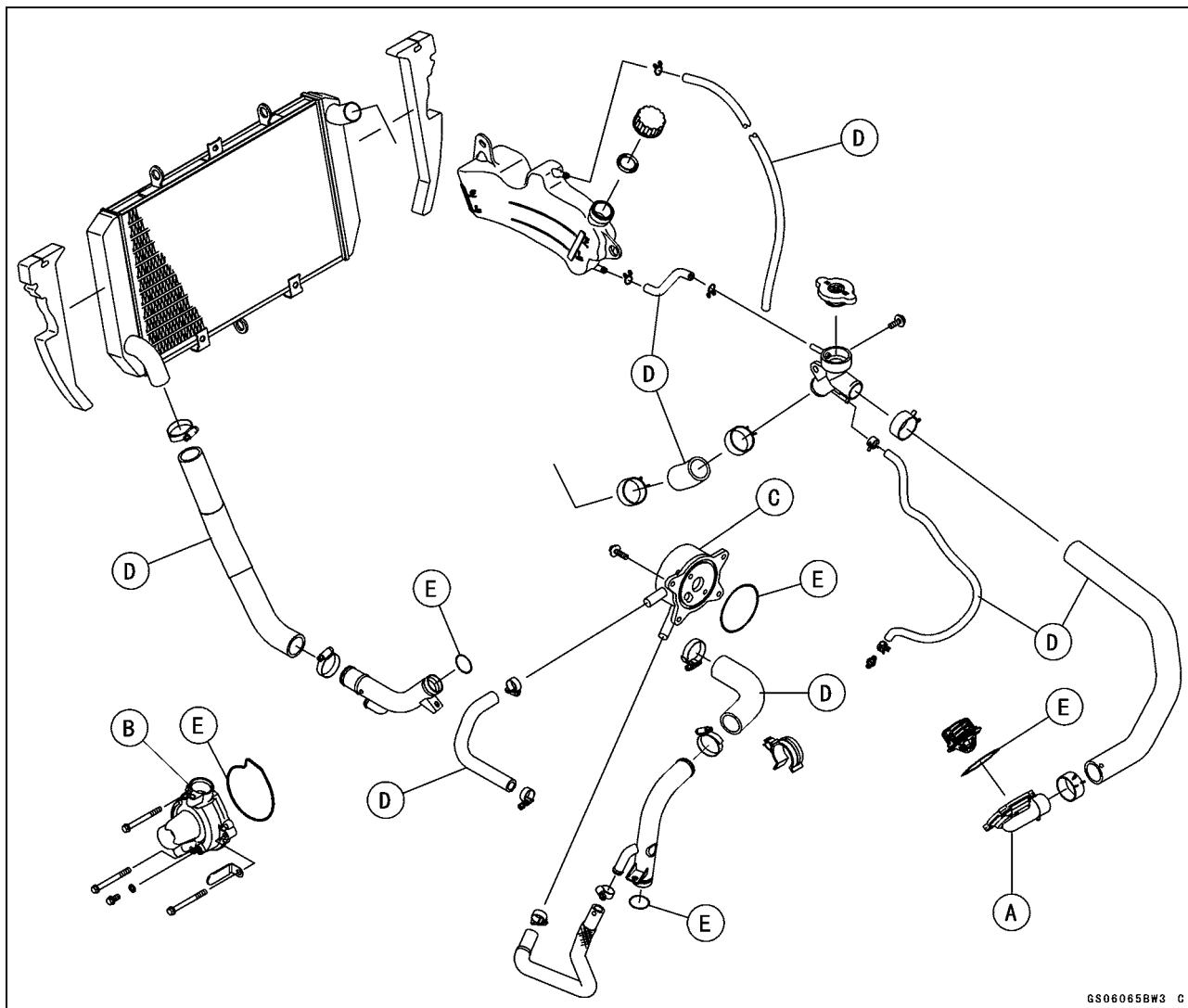

Periodic Maintenance Procedures

Engine Oil Change

- Situate the motorcycle so that it is vertical after warming up the engine.
- Remove the engine oil drain bolt [A] to drain the oil.
- The oil in the oil filter can be drained by removing the filter (see Oil Filter Replacement).
- Replace the drain bolt gasket with a new one.
- Tighten:
 - Torque - Engine Oil Drain Bolt: 29 N·m (3.0 kgf·m, 21 ft·lb)**
- Pour in the specified type and amount of oil.

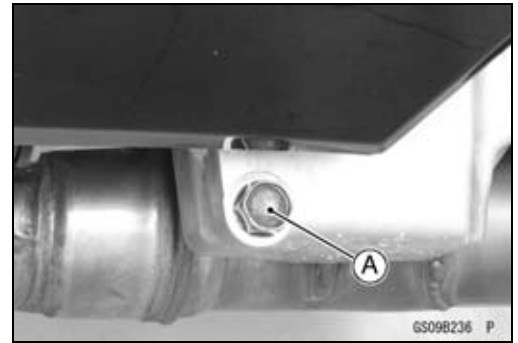

Recommended Engine Oil

- Type:** API SG, SH, SJ, SL or SM with JASO MA, MA1 or MA2
- Viscosity:** SAE 10W-40
- Capacity:** 3.2 L (3.4 US qt) (when filter is not removed)
3.8 L (4.0 US qt) (when filter is removed)
4.0 L (4.2 US qt) (when engine is completely dry)

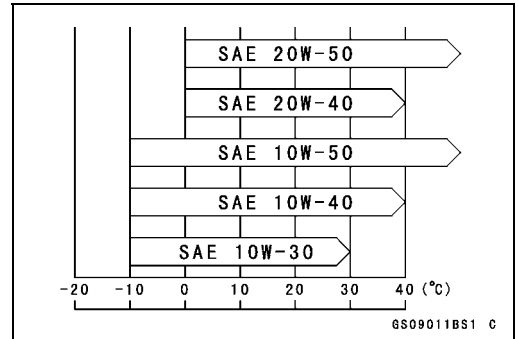

NOTE

- Do not add any chemical additive to the oil. Oils fulfilling the above requirements are fully formulated and provide adequate lubrication for both the engine and the clutch.
- Although 10W-40 engine oil is the recommended oil for most conditions, the oil viscosity may need to be changed to accommodate atmospheric conditions in your riding area.
- Check the oil level (see Oil Level Inspection in the Engine Lubrication System chapter).

Oil Filter Replacement

- Drain the engine oil (see Engine Oil Change).
- Remove the oil filter with the oil filter wrench [A].
- Special Tool - Oil Filter Wrench: 57001-1249**

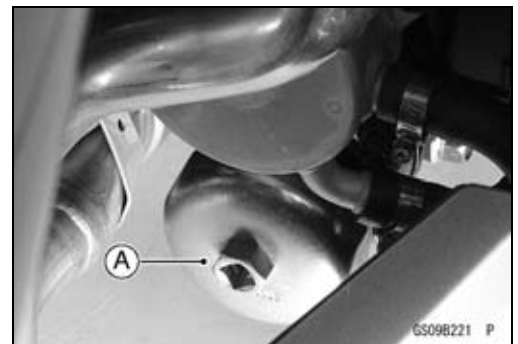

- Replace the filter with a new one.
- Apply grease to the gasket [A] before installation.
- Tighten the filter with the oil filter wrench.
- Torque - Oil Filter: 17 N·m (1.7 kgf·m, 13 ft·lb)**

NOTE

- Hand tightening of the oil filter can not be allowed since it does not reach to this tightening torque.
- Pour in the specified type and amount of oil (see Engine Oil Change).

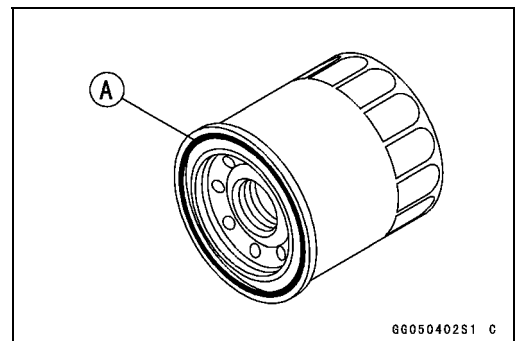

2-58 PERIODIC MAINTENANCE

Periodic Maintenance Procedures

Brake Hose Replacement

- Remove:
 - Upper Fairing (see Upper Fairing Removal in the Frame chapter)
 - Brake Hose Fitting Bolt [A]

NOTICE

Brake fluid quickly ruins painted plastic surfaces; any spilled fluid should be completely washed away immediately.

- Remove the brake hose banjo bolts [A].
- When removing the brake hose, take care not to spill the brake fluid on the painted or plastic parts.
- When removing the brake hoses [B], temporarily secure the end of the brake hose to some high place to keep fluid loss to a minimum.
- Immediately wash away any brake fluid that spills.
- There are washers on each side of the brake hose fitting.
- Replace them with new ones when installing.
- Fit the projection of the brake hose end to the calipers and master cylinders, and tighten the brake hose banjo bolts to the specified torque.

Torque - Brake Hose Banjo Bolts: 25 N·m (2.5 kgf·m, 18 ft·lb)

- When installing the hoses, avoid sharp bending, kinking, flattening or twisting, and route the hoses according to Cable, Wire, and Hose Routing section in the Appendix chapter.
- Fill the brake line after installing the brake hose (see Brake Fluid Change).

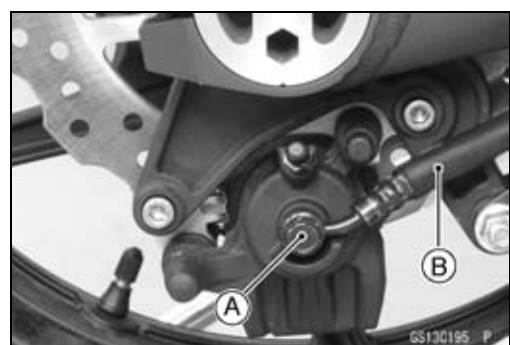
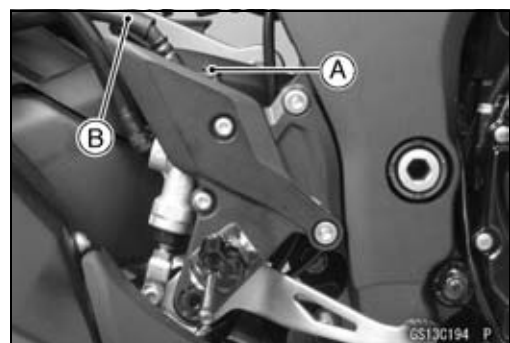
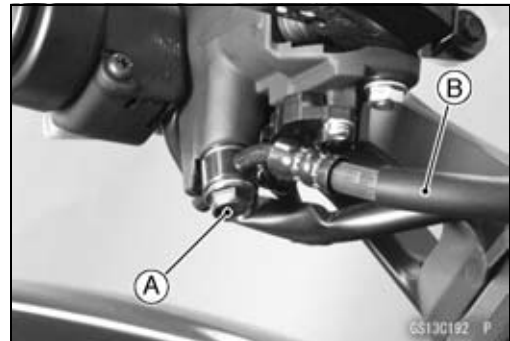

Periodic Maintenance Procedures

- For ABS equipped models; note the following.
- Remove:
 - Air Cleaner Housing (see Air Cleaner Housing Removal in the Fuel System (DFI) chapter)
 - Battery Case (see Battery Case Removal in the Frame chapter)
 - Brake Pipe Joint Nuts [A]
 - Bolts [B]
 - Clamps [C]
- Open the band [D].
- Clear the brake pipe from the holder [E].
- Remove the exhaust butterfly valve cable clamp [F].
- There are washers on each side of the brake hose fitting. Replace them with new ones when installing.
- Before installing the brake pipe, check to see that there is no damage on the threads of the brake pipe joint nut.
- ★ If there is any damage, replace the damaged parts with new ones.

NOTE

- Hand tighten the brake pipe joint nuts at both ends of the brake pipe temporarily and then tighten them to the specified torque.
- Tighten the brake pipe joint nuts with the flare nut wrench.

- Tighten:
 - Torque - Brake Hose Banjo Bolts: 25 N·m (2.5 kgf·m, 18 ft·lb)**
 - Brake Pipe Joint Nuts: 18 N·m (1.8 kgf·m, 13 ft·lb)**
- When installing the hoses, avoid sharp bending, kinking, flattening or twisting, and route the hoses according to Cable, Wire, and Hose Routing section in the Appendix chapter.
- Fill the brake line after installing the brake hose (see Brake Fluid Change).

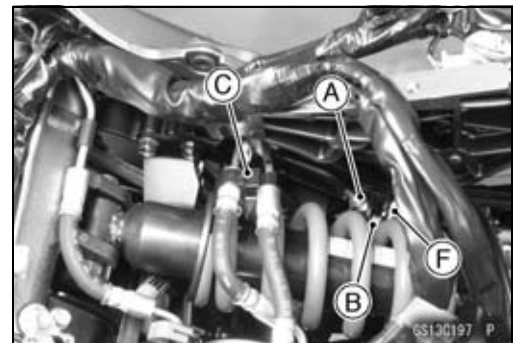
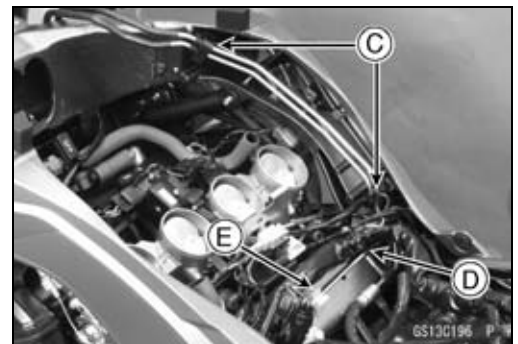
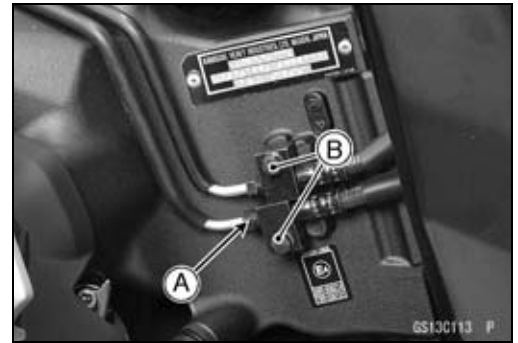

Brake Fluid Change

NOTE

- The procedure to change the front brake fluid is as follows. Changing the rear brake fluid is the same as for the front brake.

2-60 PERIODIC MAINTENANCE

Periodic Maintenance Procedures

- Level the brake fluid reservoir.
- Remove the reservoir cap.
- Remove the rubber cap from the bleed valve [A] on the caliper.
- Attach a clear plastic hose [B] to the bleed valve, and run the other end of the hose into a container.
- Fill the reservoir with fresh specified brake fluid.

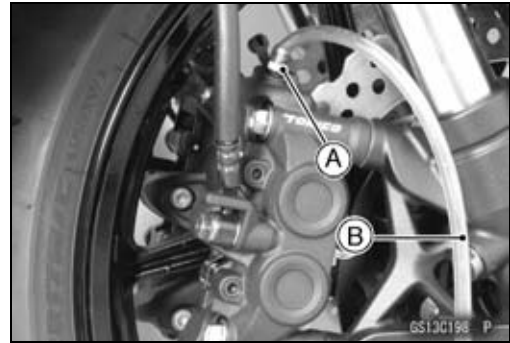

- Change the brake fluid.
- Repeat this operation until fresh brake fluid comes out from the plastic hose or the color of the fluid changes.
- 1. Open the bleed valve [A].
- 2. Apply the brake and hold it [B].
- 3. Close the bleed valve [C].
- 4. Release the brake [D].



NOTE

○ The fluid level must be checked often during the changing operation and replenished with fresh brake fluid. If the fluid in the reservoir runs out any time during the changing operation, the brakes will need to be bled since air will have entered the brake line.

○ Front Brake: Repeat the above steps for the other caliper.

- Tighten:

**Torque - Front Master Cylinder Reservoir Stopper Screw:
1.2 N·m (0.12 kgf·m, 11 in·lb)**

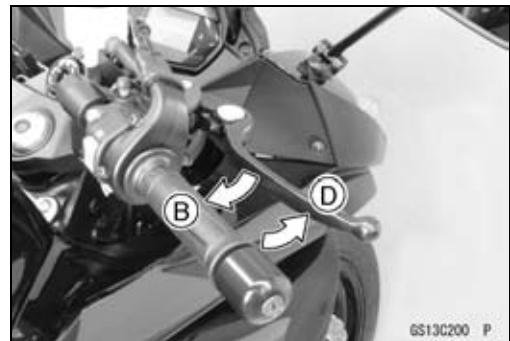

- Follow the procedure below to install the front/rear brake fluid reservoir cap correctly.
- First, tighten the rear brake fluid reservoir cap [B] clockwise [C] by hand until slight resistance is felt indicating that the cap is seated on the reservoir body, then tighten the cap an additional 1/6 turn [D] while holding the brake fluid reservoir body [A].

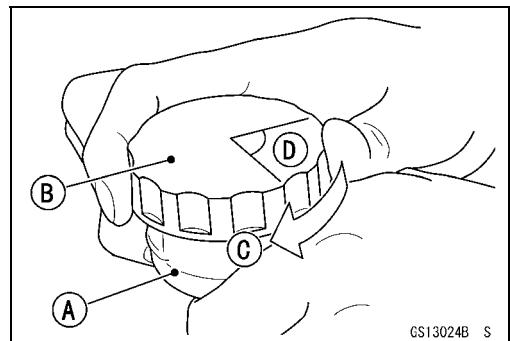

- Tighten the bleed valve, and install the rubber cap.
- Torque - Bleed Valves: 7.8 N·m (0.80 kgf·m, 69 in·lb)**
- After changing the fluid, check the brake for good braking power, no brake drag, and no fluid leakage.
- ★ If necessary, bleed the air from the lines.

Periodic Maintenance Procedures

**Master Cylinder Rubber Parts Replacement
Front Master Cylinder Disassembly**

- Remove the front master cylinder (see Front Master Cylinder Removal in the Brakes chapter).
- Remove the seal cover [A], circlip [B], connector [C] and O-ring [D].

Special Tool - Inside Circlip Pliers: 57001-143

- Unscrew the locknut [E] and pivot bolt [F], and remove the brake lever.
- Remove the bleed valve [G] and rubber cap [H].
- Remove the piston assembly [I] as follows.
 - Remove the dust cover and push rod.
 - Remove the circlip [J].
 - Pull out the piston (with primary cup and secondary cup).
 - Remove the return spring and spring guide.
- Replace:
 - Seal Cover [A]
 - Circlip [B]
 - O-ring [D]
 - Rubber Cap [H]
 - Piston Assembly [I]
 - Circlip [J]
 - Diaphragm [K]

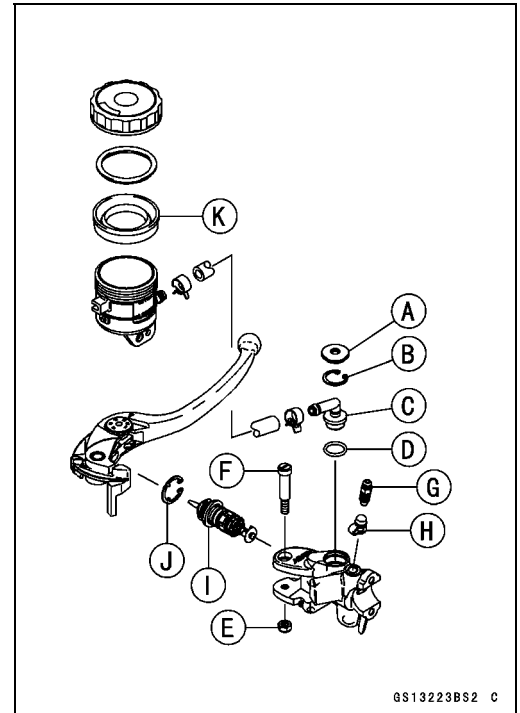

GS13223BS2 C

Rear Master Cylinder Disassembly

- Remove the rear master cylinder (see Rear Master Cylinder Removal in the Brakes chapter).
- Remove the circlip [A], connector [B] and O-ring [C].

Special Tool - Inside Circlip Pliers: 57001-143

- Slide the dust cover [D] out of place, and remove the circlip [E].
- Pull out the push rod assy [F].
- Take off the piston assy [G] and return spring [H].

NOTICE

Do not remove the secondary cup from the piston since removal will damage it.

- Replace:
 - Circlip [A]
 - O-ring [C]
 - Circlip [E]
 - Push Rod Assy [F]
 - Piston Assy [G]
 - Diaphragm [I]

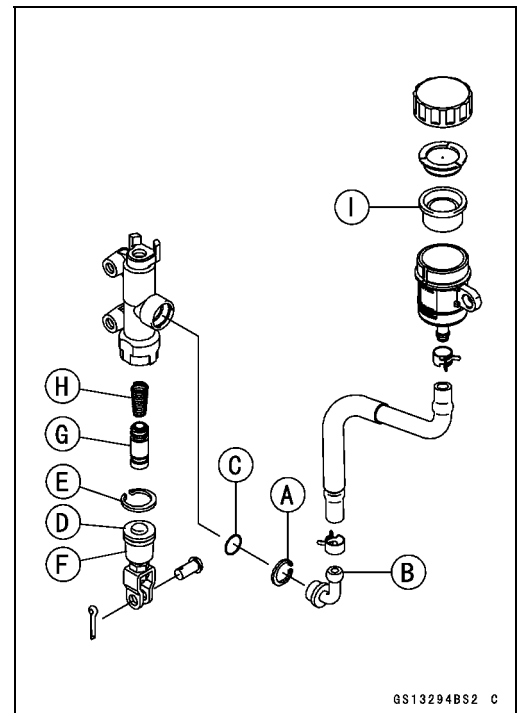

GS13294BS2 C

2-62 PERIODIC MAINTENANCE

Periodic Maintenance Procedures

Master Cylinder Assembly

- Before assembly, clean all parts including the master cylinder with brake fluid or alcohol.

NOTICE

Except for the disc pads and disc, use only disc brake fluid, isopropyl alcohol, or ethyl alcohol for cleaning brake parts. Do not use any other fluid for cleaning these parts. Gasoline, engine oil, or any other petroleum distillate will cause deterioration of the rubber parts. Oil spilled on any part will be difficult to wash off completely, and will eventually deteriorate the rubber used in the disc brake.

- Apply brake fluid to the new parts and to the inner wall of the cylinder.
- Take care not to scratch the piston or the inner wall of the cylinder.
- For the front master cylinder, apply a non-permanent locking agent to the reservoir screw and bolt.
- Apply silicone grease to the contact portion of the push rod and brake lever pivot bolt.
- Tighten:

Torque - Brake Lever Pivot Bolt: 1.0 N·m (0.10 kgf·m, 8.8 in·lb)

Brake Lever Pivot Bolt Locknut: 5.9 N·m (0.60 kgf·m, 52 in·lb)

Caliper Rubber Parts Replacement

Front Caliper Disassembly

- Loosen the front caliper pad pins [A] and banjo bolt [B] and tighten them loosely.
- Remove:
 - Front Caliper (see Front Caliper Removal in the Brakes chapter)
 - Brake Pads (see Front Brake Pad Removal in the brakes chapter)
- Remove:
 - Front Caliper Assembly Bolts [A]
- Split the front caliper.

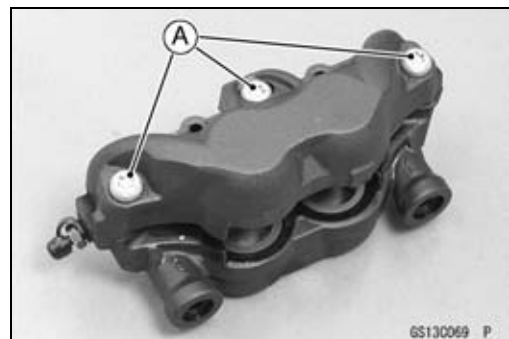
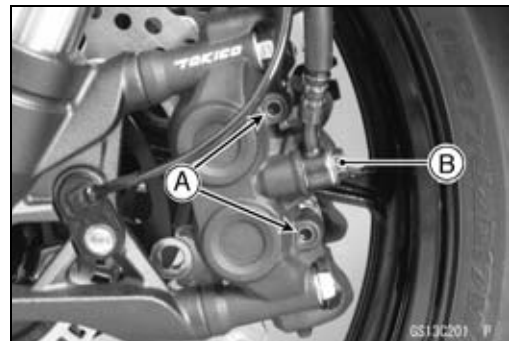

Periodic Maintenance Procedures

- Remove:
 - Pad Spring
 - O-ring [A]

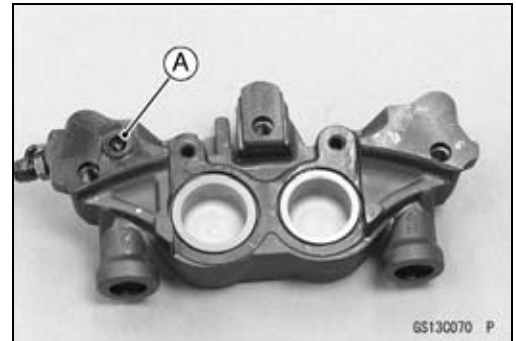

- Using compressed air, remove the pistons. One way to remove the pistons is as follows.
 - Install a rubber gasket [A] and a wooden board [B] more than 10 mm (0.4 in.) thick on the caliper half.
 - For inside caliper half [C], fasten them together with a suitable bolt and nut [D] as shown. Leave one of the oil passage [E] open.
 - Lightly apply compressed air [F] to the oil passage until the pistons hit the rubber gasket. Push down [G]

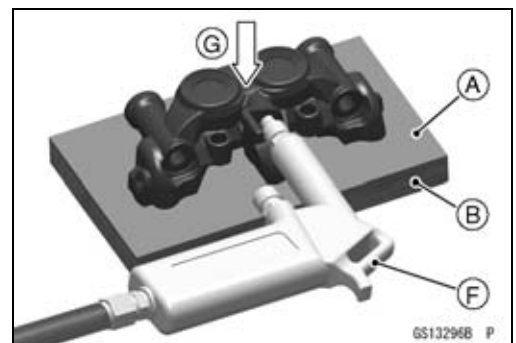
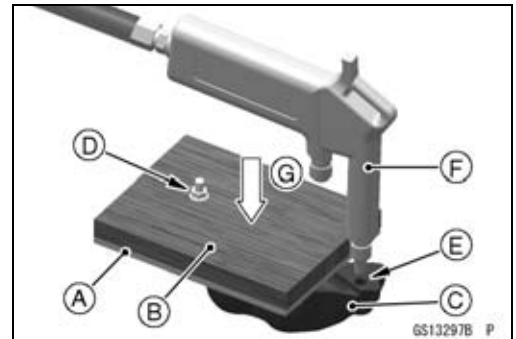

WARNING
<p>The piston in the brake caliper can crush hands and fingers. Never place your hand or fingers in front of the piston.</p>

- Pull out the pistons by hand.
- Remove the dust seals [A] and fluid seals [B].
- Remove the bleed valve [C] and rubber cap [D].
- Repeat the previous step to remove the pistons from the other side of the caliper body.

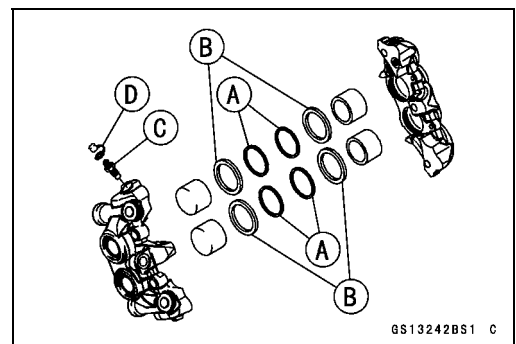

NOTE

- If compressed air is not available, do as follows for both calipers coincidentally, with the brake hose connected to the caliper.
- Prepare a container for brake fluid, and perform the work above it.
- Remove the pad springs and pads (see *Front Brake Pad Removal in the Brakes chapter*).
- Pump the brake lever until the pistons come out of the cylinders, and then disassemble the caliper.

2-64 PERIODIC MAINTENANCE

Periodic Maintenance Procedures

Front Caliper Assembly

- Clean the caliper parts except for the pads.

NOTICE

For cleaning the parts, use only disc brake fluid, isopropyl alcohol, or ethyl alcohol.

- Install the bleed valve and rubber cap.
Torque - Bleed Valves: 7.8 N·m (0.80 kgf·m, 69 in·lb)
- Replace the fluid seals [A] with new ones.
 - Apply silicone grease to the fluid seals, and install them into the cylinders by hand.
- Replace the dust seals [B] with new ones if they are damaged.
 - Apply silicone grease to the dust seals, and install them into the cylinders by hand.

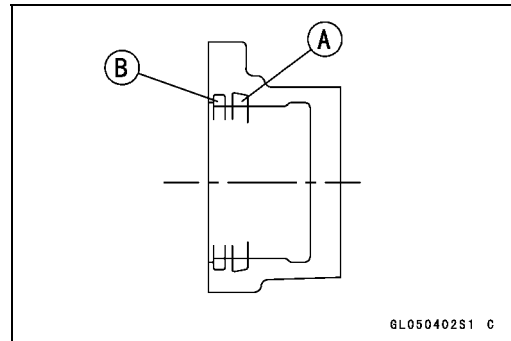

- Replace the O-ring [A] and install it.
- Apply brake fluid to the outside of the pistons, and push them into each cylinder by hand.
- Be sure to install the O-ring.
- Tighten:
Torque - Front Caliper Assembly Bolts: 22 N·m (2.2 kgf·m, 16 ft·lb)

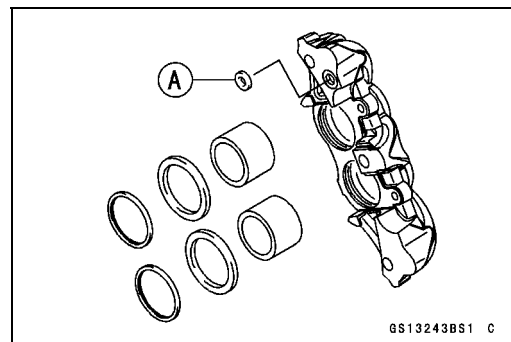

- Install the pad spring [A] as shown.
- Install the brake pads (see Front Brake Pad Installation in the Brakes chapter).
- Wipe up any spilled brake fluid on the caliper with wet cloth.

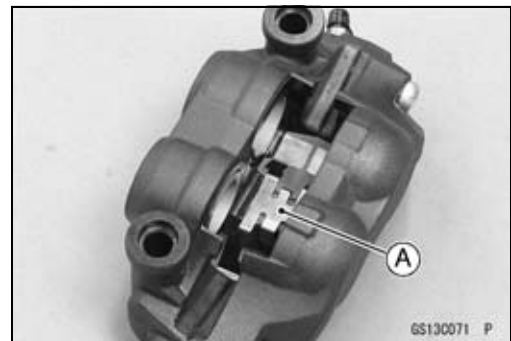

Rear Caliper Disassembly

- Remove:
 - Rear Caliper (see Rear Caliper Removal in the Brakes chapter)
 - Brake Pads (see Rear Brake Pad Removal in the Brakes chapter)
 - Caliper Holder

Periodic Maintenance Procedures

- Using a rear caliper mounting bolt [A], screw the thread hole for banjo bolt to remove the piston [B].
- Remove the pad spring [C].

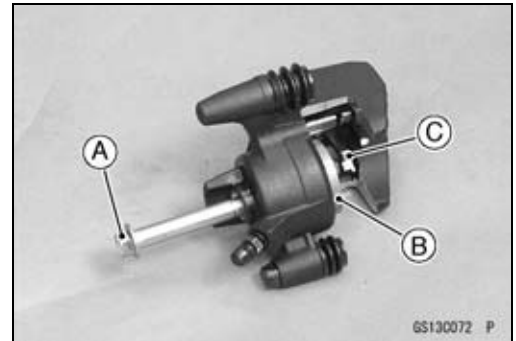

- Remove:
 - Dust Seal [A] and Fluid Seal [B]
 - Bleed Valve [C] and Rubber Cap [D]
 - Dust Boot [E]
 - Friction Boot [F]

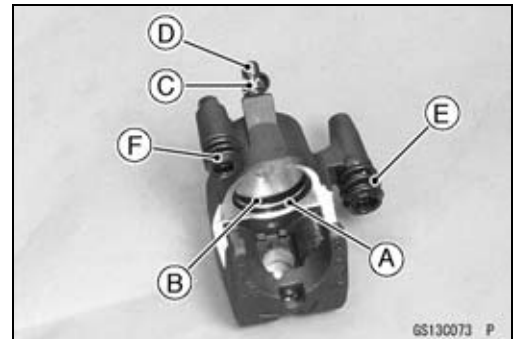

Rear Caliper Assembly

- Clean the caliper parts except for the pads.

NOTICE

For cleaning the parts, use only disc brake fluid, isopropyl alcohol, or ethyl alcohol.

- Install the bleed valve and rubber cap.
 - Torque - Bleed Valve: 7.8 N·m (0.80 kgf·m, 69 in·lb)**
- Apply brake fluid to the cylinder bore.
- Replace the fluid seal [A] with a new one.
- Apply silicone grease to the fluid seal, and install it into the cylinder by hand.
- Replace the dust seal [B] with a new one.
- Apply brake fluid to the outside of the piston, and push it into the cylinder by hand as far as it will go.
- Replace the friction boot [C] and dust boot [D] with new ones.
- Apply silicone grease to the sliding surface of the caliper holder shafts [E].
- Check that the guide [F] is in place on the caliper holder.
- Install the pad spring [G].
- Install the pads (see Rear Brake Pad Installation in the Brakes chapter).
- Wipe up any spilled brake fluid on the caliper with wet cloth.

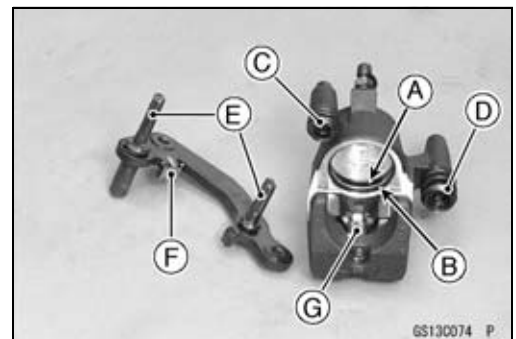

2-66 PERIODIC MAINTENANCE

Periodic Maintenance Procedures

Spark Plug Replacement

- Remove the stick coils (see Stick Coil Removal in the Electrical System chapter).
- Remove the spark plugs [A] using the plug wrench [B] vertically.

Special Tool - Spark Plug Wrench, Hex 16: 57001-1262

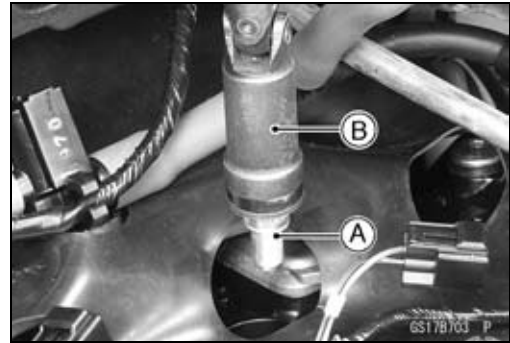

- Replace the spark plug with a new one.

Standard Spark Plug

Type: NGK CR9EIA-9

- Insert new spark plug in the plug wrench.
- Using the plug wrench vertically, tighten the plug.

NOTICE

The insulator of the spark plug may break if when the wrench is inclined during tightening.

Torque - Spark Plugs: 13 N·m (1.3 kgf·m, 115 in·lb)

- Install the stick coils securely.
- Be sure the stick coils are installed by pulling up it lightly.

Fuel System (DFI)

Table of Contents

Exploded View.....	3-4
DFI System.....	3-10
DFI Parts Location.....	3-16
Specifications	3-18
Special Tools and Sealant	3-20
DFI Servicing Precautions.....	3-22
DFI Servicing Precautions	3-22
Troubleshooting the DFI System.....	3-24
Outline	3-24
Inquiries to Rider.....	3-28
DFI System Troubleshooting Guide	3-31
Self-Diagnosis	3-36
Self-diagnosis Outline.....	3-36
Self-diagnosis Procedures.....	3-37
Service Code Reading	3-40
Service Code Erasing	3-41
Backups.....	3-42
Main Throttle Sensor (Service Code 11)	3-45
Main Throttle Sensor Removal/Adjustment	3-45
Main Throttle Sensor Input Voltage Inspection	3-45
Main Throttle Sensor Output Voltage Inspection	3-46
Main Throttle Sensor Resistance Inspection	3-48
Intake Air Pressure Sensor #1 (Service Code 12).....	3-49
Intake Air Pressure Sensor #1 Removal.....	3-49
Intake Air Pressure Sensor #1 Installation.....	3-49
Intake Air Pressure Sensor #1 Input Voltage Inspection.....	3-50
Intake Air Pressure Sensor #1 Output Voltage Inspection.....	3-51
Intake Air Temperature Sensor (Service Code 13).....	3-55
Intake Air Temperature Sensor Removal/Installation.....	3-55
Intake Air Temperature Sensor Output Voltage Inspection.....	3-55
Intake Air Temperature Sensor Resistance Inspection	3-56
Water Temperature Sensor (Service Code 14)	3-58
Water Temperature Sensor Removal/Installation	3-58
Water Temperature Sensor Output Voltage Inspection.....	3-59
Water Temperature Sensor Resistance Inspection.....	3-60
Intake Air Pressure Sensor #2 (Service Code 16).....	3-61
Intake Air Pressure Sensor #2 Removal.....	3-61
Intake Air Pressure Sensor #2 Installation.....	3-61
Intake Air Pressure Sensor #2 Input Voltage Inspection.....	3-62
Intake Air Pressure Sensor #2 Output Voltage Inspection.....	3-63
Crankshaft Sensor (Service Code 21).....	3-65
Crankshaft Sensor Removal/Installation.....	3-65
Crankshaft Sensor Resistance Inspection	3-65
Crankshaft Sensor Peak Voltage Inspection.....	3-65
Speed Sensor (Service Code 24, 25).....	3-66
Speed Sensor Removal/Installation.....	3-66
Speed Sensor Inspection.....	3-66
Speed Sensor Input Voltage Inspection.....	3-66
Speed Sensor Output Voltage Inspection	3-67
Vehicle-down Sensor (Service Code 31).....	3-69

3-2 FUEL SYSTEM (DFI)

Vehicle-down Sensor Removal	3-69
Vehicle-down Sensor Installation	3-70
Vehicle-down Sensor Input Voltage Inspection	3-70
Vehicle-down Sensor Output Voltage Inspection	3-71
Subthrottle Sensor (Service Code 32)	3-74
Subthrottle Sensor Removal/Adjustment	3-74
Subthrottle Sensor Input Voltage Inspection	3-74
Subthrottle Sensor Output Voltage Inspection	3-75
Subthrottle Sensor Resistance Inspection	3-77
Oxygen Sensor - not activated (Service Code 33, Equipped Models)	3-78
Oxygen Sensor Removal/Installation	3-78
Oxygen Sensor Inspection	3-78
Exhaust Butterfly Valve Actuator Sensor (Service Code 34)	3-81
Exhaust Butterfly Valve Actuator Sensor Removal/Installation	3-81
Exhaust Butterfly Valve Actuator Sensor Input Voltage Inspection	3-81
Exhaust Butterfly Valve Actuator Sensor Output Voltage Inspection	3-82
Exhaust Butterfly Valve Actuator Sensor Resistance Inspection	3-83
Immobilizer Amplifier (Service Code 35, Equipped Models)	3-84
Antenna Resistance Inspection	3-84
Amplifier Input Voltage Inspection	3-85
Blank Key Detection (Service Code 36, Equipped Models)	3-86
Ignition Key Inspection	3-86
ECU Communication Error (Service Code 39)	3-87
ECU Communication Line Inspection	3-87
Stick Coils #1, #2, #3, #4 (Service Code 51, 52, 53, 54)	3-88
Stick Coil Removal/Installation	3-88
Stick Coil Primary Winding Resistance Inspection	3-88
Stick Coil Input Voltage Inspection	3-88
Radiator Fan Relay (Service Code 56)	3-90
Radiator Fan Relay Removal/Installation	3-90
Radiator Fan Relay Inspection	3-90
Subthrottle Valve Actuator (Service Code 62)	3-91
Subthrottle Valve Actuator Removal	3-91
Subthrottle Valve Actuator Inspection	3-91
Subthrottle Valve Actuator Resistance Inspection	3-91
Subthrottle Valve Actuator Input Voltage Inspection	3-92
Exhaust Butterfly Valve Actuator (Service Code 63)	3-94
Exhaust Butterfly Valve Actuator Removal	3-94
Exhaust Butterfly Valve Actuator Installation	3-94
Exhaust Butterfly Valve Actuator Inspection	3-96
Exhaust Butterfly Valve Actuator Resistance Inspection	3-96
Air Switching Valve (Service Code 64)	3-98
Air Switching Valve Removal/Installation	3-98
Air Switching Valve Inspection	3-98
Oxygen Sensor Heater (Service Code 67, Equipped Models)	3-99
Oxygen Sensor Heater Removal/Installation	3-99
Oxygen Sensor Heater Resistance Inspection	3-99
Oxygen Sensor Heater Power Source Voltage Inspection	3-100
Oxygen Sensor - Incorrect Output Voltage (Service Code 94, Equipped Models)	3-102
Oxygen Sensor Removal/Installation	3-102
Oxygen Sensor Inspection	3-102
Warning Indicator Light (LED)	3-105
Light (LED) Inspection	3-105
ECU	3-106
ECU Identification	3-106
ECU Removal	3-106
ECU Installation	3-106

ECU Power Supply Inspection	3-107
DFI Power Source	3-110
ECU Fuse Removal	3-110
ECU Fuse Installation	3-110
ECU Fuse Inspection	3-110
ECU Main Relay Removal/Installation	3-110
ECU Main Relay Inspection	3-110
Fuel Line.....	3-111
Fuel Pressure Inspection	3-111
Fuel Flow Rate Inspection	3-112
Fuel Pump	3-114
Fuel Pump Removal	3-114
Fuel Pump Installation	3-115
Fuel Pump Operation Inspection	3-115
Fuel Pump Operating Voltage Inspection	3-116
Pressure Regulator Removal.....	3-116
Pump Screen, Fuel Filter Cleaning.....	3-117
Fuel Pump Relay Removal/Installation.....	3-117
Fuel Pump Relay Inspection.....	3-117
Fuel Injectors.....	3-119
Fuel Injector Removal/Installation.....	3-119
Fuel Injector Audible Inspection.....	3-119
Fuel Injector Resistance Inspection.....	3-119
Fuel Injector Power Source Voltage Inspection	3-120
Fuel Injector Output Voltage Inspection.....	3-121
Fuel Injector Fuel Line Inspection	3-122
Throttle Grip and Cables	3-124
Free Play Inspection	3-124
Free Play Adjustment.....	3-124
Cable Installation	3-124
Cable Lubrication.....	3-124
Throttle Body Assy	3-125
Idle Speed Inspection/Adjustment	3-125
Synchronization Inspection/Adjustment.....	3-125
Throttle Body Assy Removal.....	3-125
Throttle Body Assy Installation.....	3-127
Throttle Body Assy Disassembly	3-128
Throttle Body Assy Assembly	3-129
Air Cleaner.....	3-130
Air Cleaner Element Removal/Installation	3-130
Air Cleaner Element Inspection	3-130
Air Cleaner Oil Draining	3-130
Air Cleaner Housing Removal.....	3-130
Air Cleaner Housing Installation.....	3-131
Fuel Tank.....	3-132
Fuel Tank Removal	3-132
Fuel Tank Installation	3-135
Fuel Tank and Cap Inspection	3-137
Fuel Tank Cleaning	3-137
Evaporative Emission Control System (CAL and SEA-B1 Models).....	3-138
Parts Removal/Installation	3-138
Hose Inspection	3-138
Separator Inspection.....	3-138
Separator Operation Test.....	3-139
Canister Inspection	3-139

3-4 FUEL SYSTEM (DFI)

Exploded View

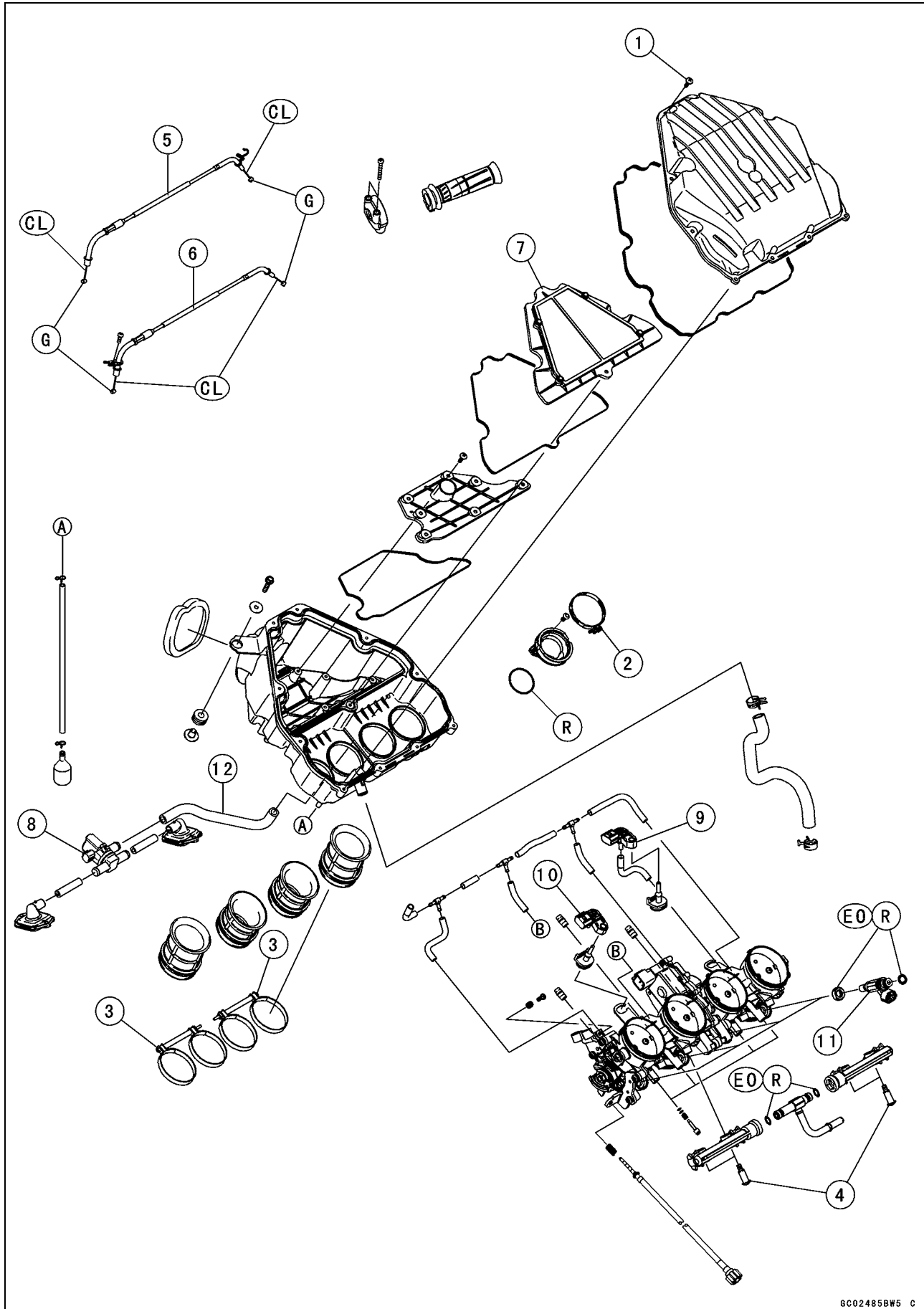

Exploded View

No.	Fastener	Torque			Remarks
		N·m	kgf·m	ft·lb	
1	Upper Air Cleaner Housing Screws	1.1	0.11	9.7 in·lb	
2	Throttle Body Assy Holder Clamp Bolts	2.9	0.30	26 in·lb	
3	Air Cleaner Duct Clamp Bolts	2.0	0.20	18 in·lb	
4	Delivery Pipe Assy Mounting Screws	3.4	0.35	30 in·lb	

- 5. Throttle Cable (Accelerator)
 - 6. Throttle Cable (Decelerator)
 - 7. Air Cleaner Element
 - 8. Air Switching Valve
 - 9. Intake Air Pressure Sensor #2
 - 10. Intake Air Pressure Sensor #1
 - 11. Fuel Injectors
 - 12. other than CAL and SEA-B1 Models
- CL: Apply cable lubricant.
 EO: Apply engine oil
 G: Apply grease.
 R: Replacement Parts

3-6 FUEL SYSTEM (DFI)

Exploded View

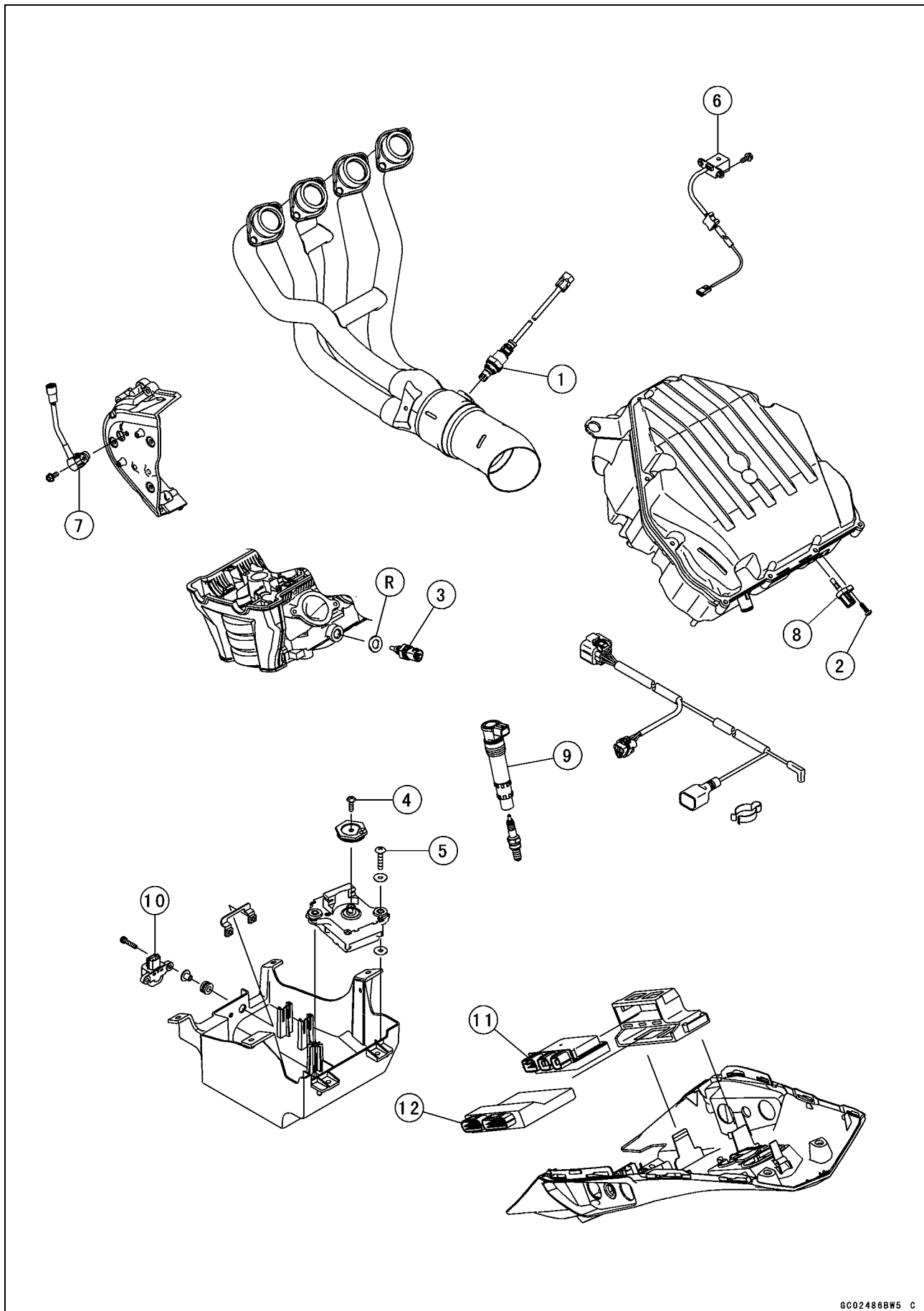

Exploded View

No.	Fastener	Torque			Remarks
		N·m	kgf·m	ft·lb	
1	Oxygen Sensor (Equipped Models)	44	4.5	32	
2	Intake Air Temperature Sensor Mounting Screw	1.2	0.12	11 in·lb	
3	Water Temperature Sensor	30	3.0	22	
4	Exhaust Butterfly Valve Actuator Pulley Bolt	5.0	0.51	44 in·lb	
5	Exhaust Butterfly Valve Actuator Mounting Screws	1.2	0.12	11 in·lb	

- 6. Crankshaft Sensor
 - 7. Speed Sensor
 - 8. Intake Air Temperature Sensor
 - 9. Stick Coils
 - 10. Vehicle-down Sensor
 - 11. Relay Box
 - 12. ECU
- R: Replacement Parts

3-8 FUEL SYSTEM (DFI)

Exploded View

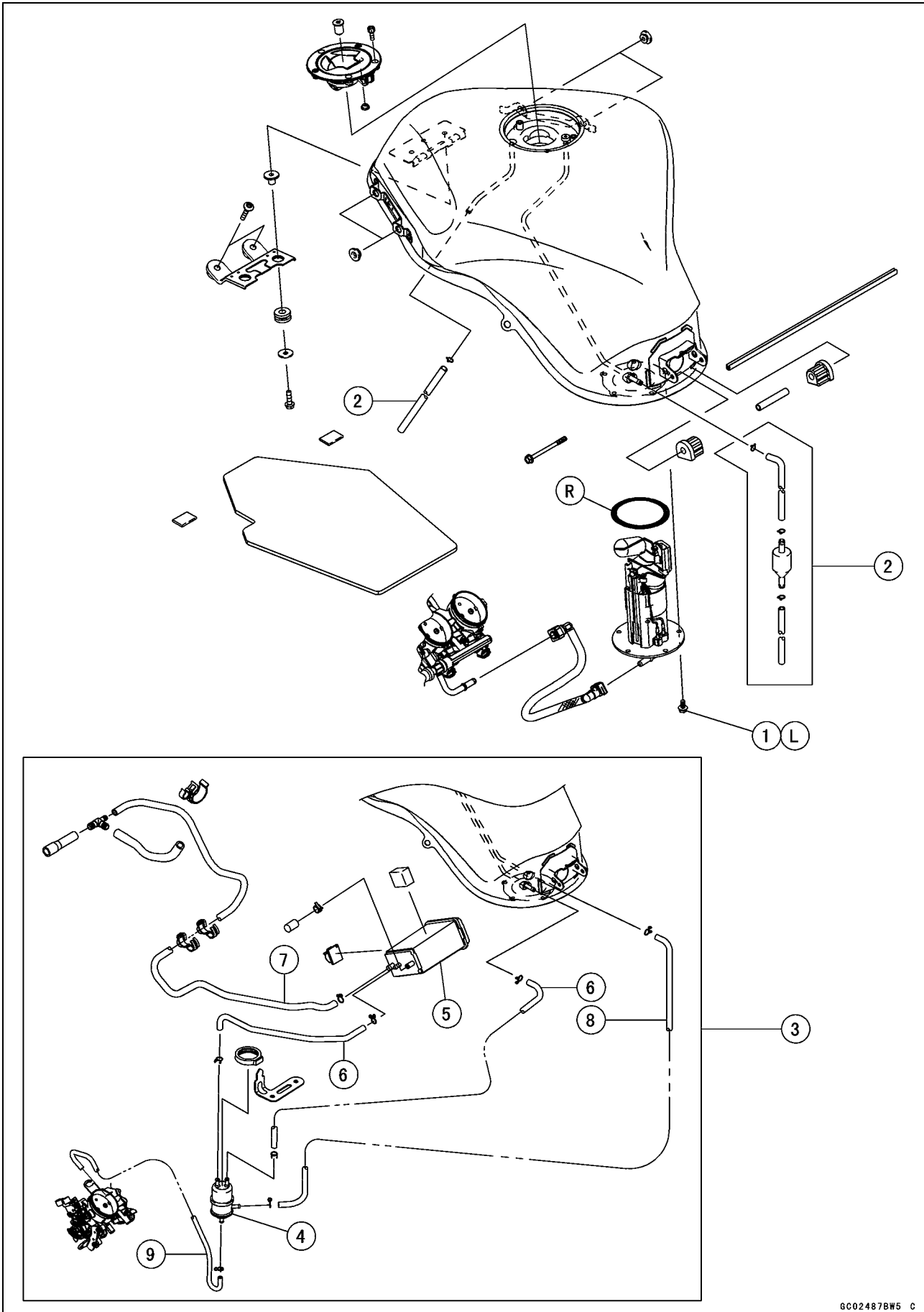

Exploded View

No.	Fastener	Torque			Remarks
		N·m	kgf·m	ft·lb	
1	Fuel Pump Bolts	9.8	1.0	87 in·lb	L

- 2. Other than CAL and SEA-B1 Models
 - 3. CAL and SEA-B1 Models
 - 4. Separator
 - 5. Canister
 - 6. Blue Hose (Breather)
 - 7. Green Hose (Purge)
 - 8. Red Hose (Return)
 - 9. White Hose (Vacuum)
- L: Apply a non-permanent locking agent.
R: Replacement Parts

3-10 FUEL SYSTEM (DFI)

DFI System

DFI System

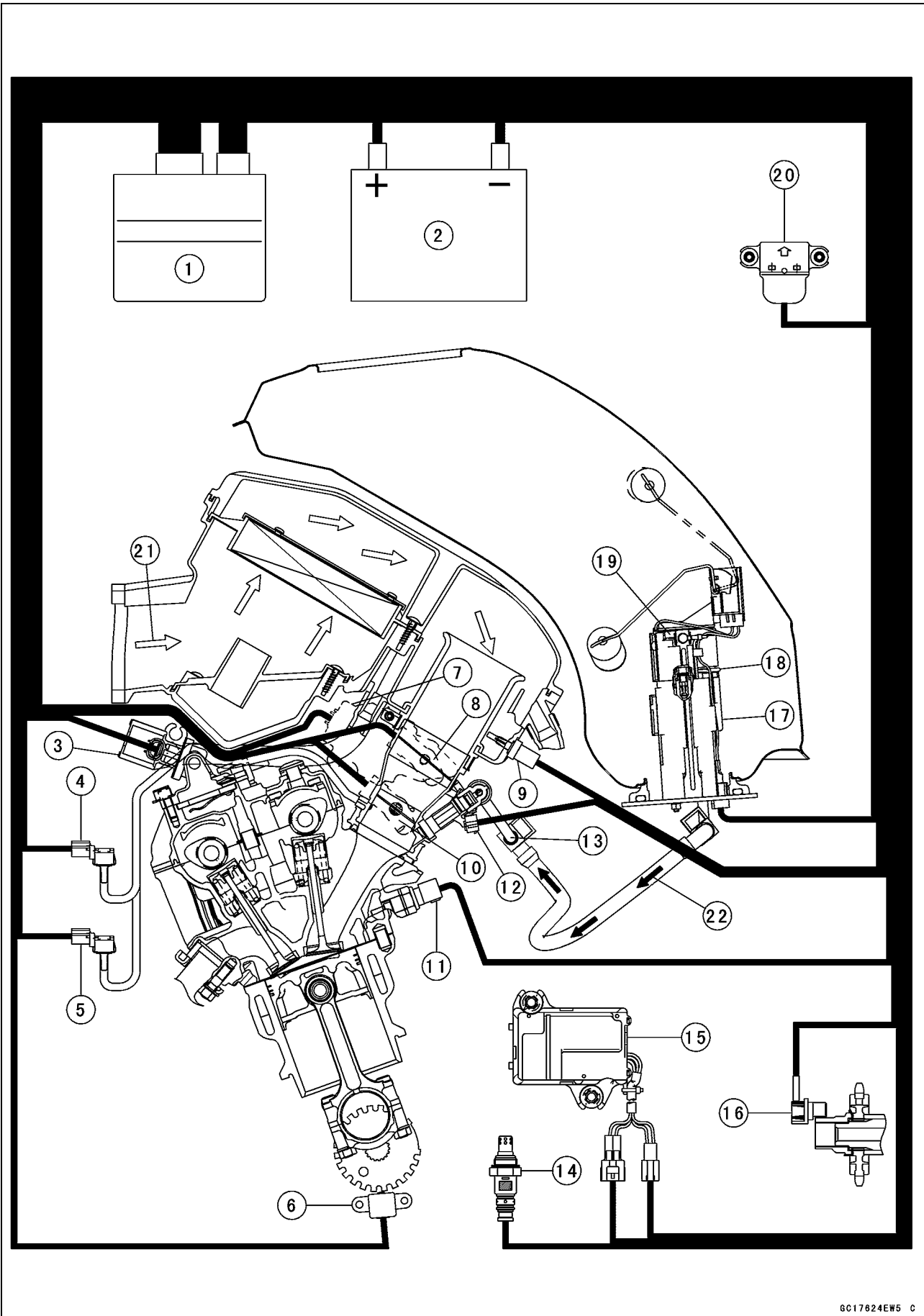

DFI System

1. ECU
2. Battery 12 V 8 Ah
3. Air Switching Valve
4. Intake Air Pressure Sensor #1
5. Intake Air Pressure Sensor #2
6. Crankshaft Sensor
7. Subthrottle Valve Actuator
8. Subthrottle Sensor
9. Intake Air Temperature Sensor
10. Main Throttle Sensor
11. Water Temperature Sensor
12. Fuel Injectors
13. Delivery Pipe Assy
14. Oxygen Sensor (Equipped Models)
15. Exhaust Butterfly Valve Actuator
16. Speed Sensor
17. Fuel Pump
18. Pressure Regulator
19. Fuel Filter
20. Vehicle-down Sensor
21. Air Flow
22. Fuel Flow

3-12 FUEL SYSTEM (DFI)

DFI System

DFI System Wiring Diagram

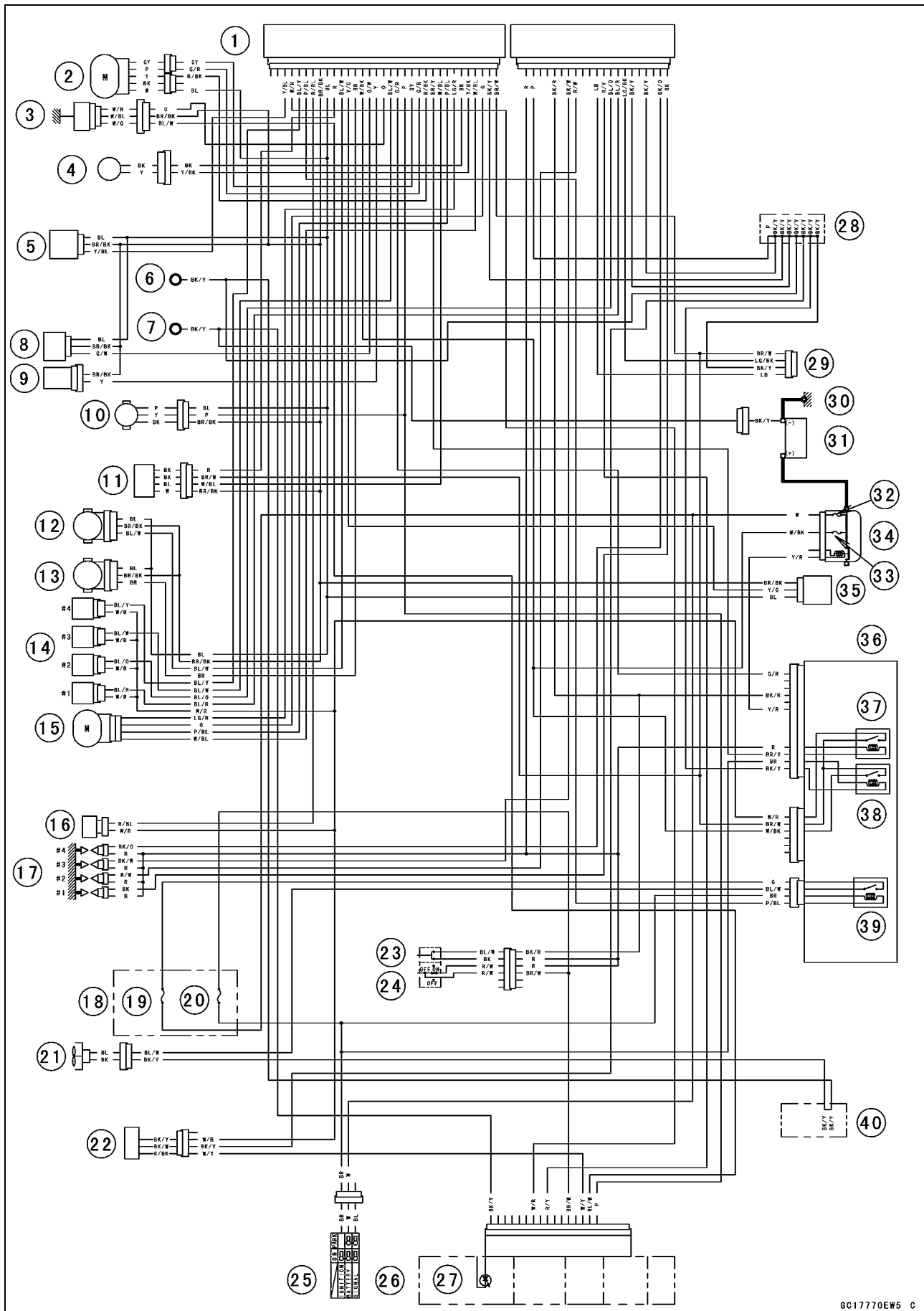

DFI System

Part Names

1. ECU
2. Exhaust Butterfly Valve Actuator
3. Water Temperature Sensor
4. Crankshaft Sensor
5. Intake Air Pressure Sensor #1
6. Frame Ground
7. Meter Ground
8. Intake Air Pressure Sensor #2
9. Intake Air Temperature Sensor
10. Speed Sensor
11. Oxygen Sensor
12. Main Throttle Sensor
13. Subthrottle Sensor
14. Fuel Injectors
15. Subthrottle Valve Actuator
16. Air Switching Valve
17. Stick Coils
18. Fuse Box 2
19. Fan Fuse 15 A
20. Ignition Fuse 15 A
21. Radiator Fan Motor
22. Fuel Pump/Fuel Level Sensor
23. Starter Button
24. Engine Stop Switch
25. Ignition Switch
26. Meter Unit
27. Oil Pressure/FI/Immobilizer Warning Indicator Light (LED)
28. Water-proof Joint C
29. Immobilizer (Equipped Models)/Kawasaki Diagnostic System Connector
30. Engine Ground
31. Battery 12 V 8 Ah
32. Main Fuse 30 A
33. FI Fuse 15 A
34. Starter Relay
35. Vehicle-down Sensor
36. Relay Box
37. Fuel Pump Relay
38. ECU Main Relay
39. Radiator Fan Relay
40. Water-proof Joint A

○Color Codes:

BK: Black	GY: Gray	PU: Purple
BL: Blue	LB: Light Blue	R: Red
BR: Brown	LG: Light Green	V: Violet
CH: Chocolate	O: Orange	W: White
DG: Dark Green	P: Pink	Y: Yellow
G: Green		

3-14 FUEL SYSTEM (DFI)

DFI System

Terminal Numbers of ECU Connectors

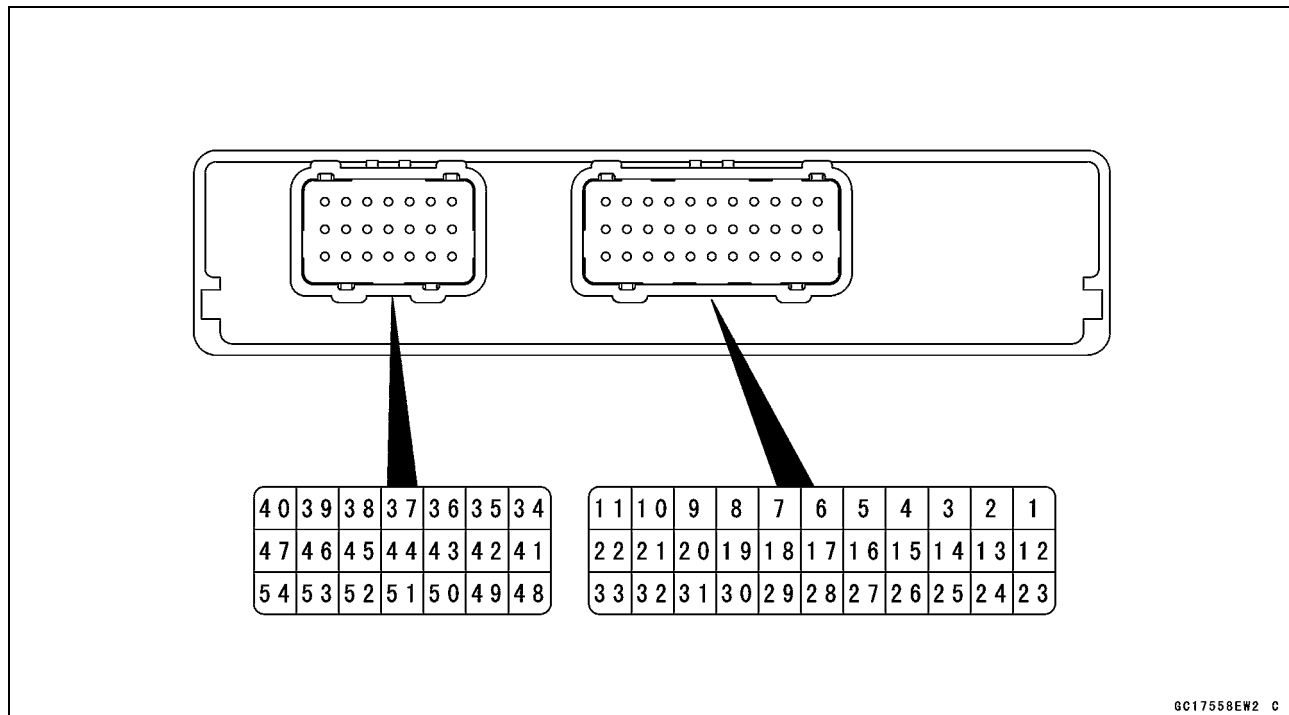

Terminal Names

1. Subthrottle Valve Actuator: LG/R
2. Exhaust Butterfly Valve Actuator (-): GY
3. Exhaust Butterfly Valve Actuator (+): G/R
4. Fuel Pump Relay: BR/Y
5. Power Supply to Sensors: BL
6. Power Supply to ECU (from ECU Main Relay): BR/W
7. Air Switching Valve: R/BL
8. Power Supply to ECU (from Battery): W/BK
9. Oxygen Sensor Heater (Equipped Models): R
10. Fuel Injector #4: BL/Y
11. Fuel Injector #3: BL/W
12. Subthrottle Valve Actuator: P/BL
13. Unused
14. Unused
15. Intake Air Temperature Sensor: Y
16. Intake Air Pressure Sensor #2: G/W
17. Intake Air Pressure Sensor #1: Y/BL
18. Radiator Fan Relay: P/BL
19. Vehicle-down Sensor: Y/G
20. Crankshaft Sensor (+): Y/BK
21. Crankshaft Sensor (-): BK
22. Speed Sensor: P
23. Subthrottle Valve Actuator: G
24. Subthrottle Valve Actuator: W/BL
25. Sidestand Switch: G/R
26. Main Throttle Sensor: BL/W
27. Subthrottle Sensor: BR
28. Exhaust Butterfly Valve Actuator Sensor: R/BK
29. Water Temperature Sensor: O
30. Ground for ECU: BK/Y
31. Warning Indicator Light (LED) (Meter Unit): W/R
32. Oxygen Sensor (Equipped Models): W/BL
33. Ground for Sensors: BR/BK
34. Fuel Injector #2: BL/O

DFI System

- 35. Starter Button: BK/R
 - 36. Fuel Injector #1: BL/R
 - 37. Engine Stop Switch: R
 - 38. Stick Coil #4: BK/O
 - 39. Stick Coil #3: BK/W
 - 40. Stick Coil #1: BK
 - 41. External Communication Line (Immobilizer System, Equipped Models/*KDS): LG/BK
 - 42. Unused
 - 43. Neutral Switch: LG
 - 44. Starter Lockout Switch: R/G
 - 45. Immobilizer Amplifier (Equipped Models): V
 - 46. Unused
 - 47. Stick Coil #2: R/W
 - 48. Ground: P
 - 49. Unused
 - 50. External Communication Line (Immobilizer System, Equipped Models/*KDS): LB
 - 51. Meter Unit (Tachometer): R/Y
 - 52. Immobilizer Amplifier (Equipped Models): P/BK
 - 53. Ground for Fuel System: BK/Y
 - 54. Ground for Ignition System: BK/Y
- *: KDS (Kawasaki Diagnostic System)

3-16 FUEL SYSTEM (DFI)

DFI Parts Location

Main Throttle Sensor [A]
Subthrottle Sensor [B]

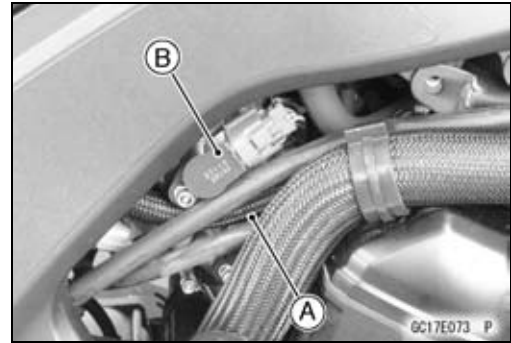

Crankshaft Sensor [A]
Oxygen Sensor [B] (Equipped Models)

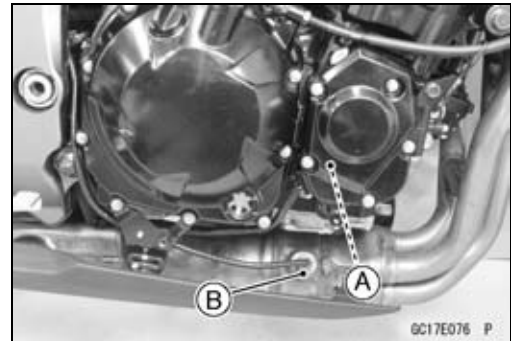

Ignition Key (Transponder, Equipped Models) [A]
Ignition Switch [B]
Immobilizer Antenna [C] (Equipped Models)
Warning Indicator Light (LED) [D]

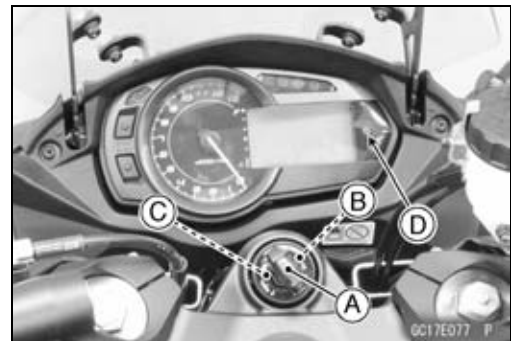

Stick Coils [A]
Air Switching Valve [B]
Intake Air Pressure Sensor #1 [C]
Intake Air Pressure Sensor #2 [D]
Subthrottle Valve Actuator [E]
Fuel Injectors [F]

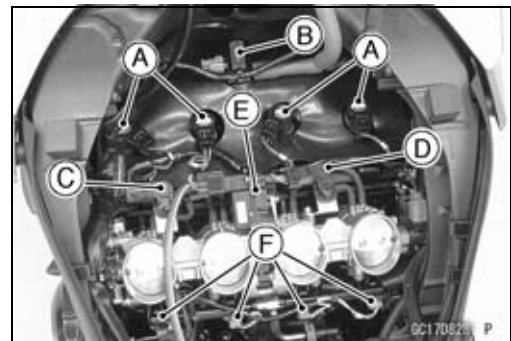

Water Temperature Sensor [A]
Speed Sensor [B]
Engine Ground [C]

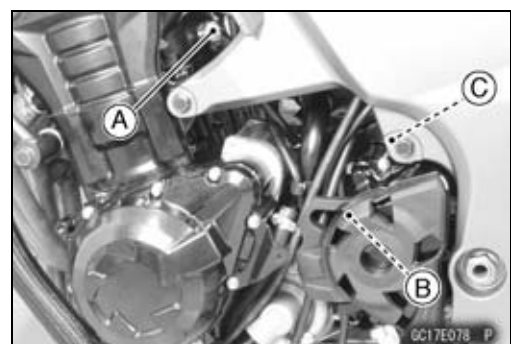

DFI Parts Location

Immobilizer Amplifier [A] (Equipped Models)

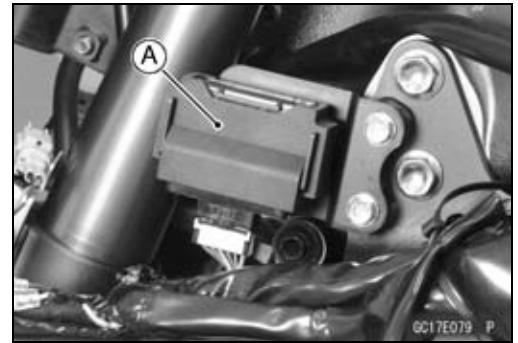

Intake Air Temperature Sensor [A]
Frame Ground [B]

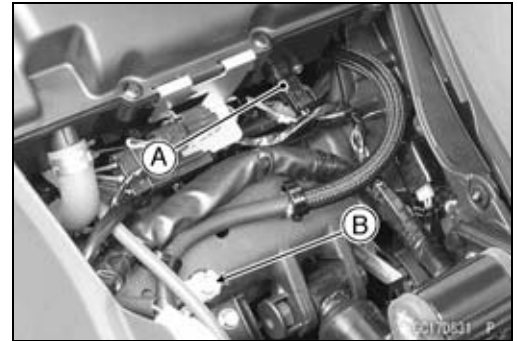

Exhaust Butterfly Valve Actuator [A]
Battery 12 V 8 Ah [B]
Vehicle-down Sensor [C]
FI Fuse 15 A [D]

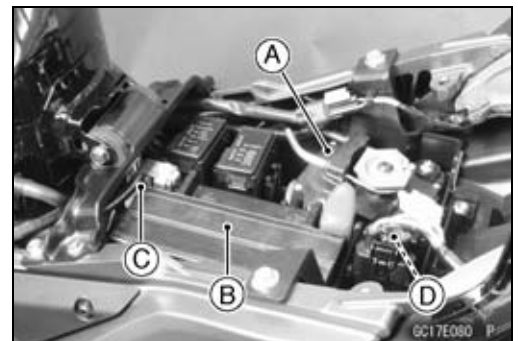

Relay Box (ECU Main Relay, Radiator Fan Relay, Fuel Pump Relay) [A]
ECU [B]
Immobilizer (Equipped Models)/Kawasaki Diagnostic System Connector [C]

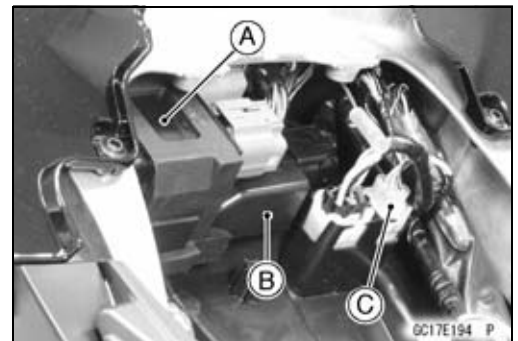

Fuel Pump [A]



3-18 FUEL SYSTEM (DFI)

Specifications

Item	Standard
Digital Fuel Injection System	
Idle Speed	1 100 ±50 r/min (rpm)
Throttle Body Assy:	
Throttle Valve	Dual throttle
Bore	φ38 mm (1.42 in.)
Throttle Body Vacuum	40.7 ±1.3 kPa (305 ±10 mmHg)
Bypass Screws (Turn Out)	2 1/2 (for reference)
ECU:	
Make	DENSO
Type	Digital memory type, with built in IC igniter, sealed with resin
Fuel Pressure (High Pressure Line)	294 kPa (3.0 kgf/cm ² , 43 psi) with engine idling
Fuel Pump:	
Type	In-tank friction pump
Discharge	50 mL (1.7 US oz.) or more for 3 seconds
Fuel Injectors:	
Type	INP-289
Nozzle Type	Fine atomizing type with 8 holes
Resistance	About 11.7 ~ 12.3 Ω at 20°C (68°F)
Main Throttle Sensor:	
Input Voltage	DC 4.75 ~ 5.25 V
Output Voltage	DC 1.02 ~ 1.06 V at idle throttle opening DC 4.22 ~ 4.42 V at full throttle opening (for reference)
Resistance	4 ~ 6 kΩ
Intake Air Pressure Sensor #1/Intake Air Pressure Sensor #2:	
Input Voltage	DC 4.75 ~ 5.25 V
Output Voltage	DC 3.80 ~ 4.20 V at standard atmospheric pressure (see this text for details)
Intake Air Temperature Sensor:	
Output Voltage	About DC 2.25 ~ 2.50 V at 20°C (68°F)
Resistance	5.4 ~ 6.6 kΩ at 0°C (32°F) 0.29 ~ 0.39 kΩ at 80°C (176°F)
Water Temperature Sensor:	
Output Voltage	About DC 2.80 ~ 2.97 V at 20°C (68°F)
Speed Sensor:	
Input Voltage	About DC 9 ~ 11 V
Output Voltage	Less than DC 0.6 V or Over than 4.8 V at ignition switch ON and 0 km/h
Vehicle-down Sensor:	
Input Voltage	DC 4.75 ~ 5.25 V
Output Voltage	With sensor tilted 60 ~ 70° or more right or left: DC 0.65 ~ 1.35 V With sensor arrow mark pointed up: DC 3.55 ~ 4.45 V

Specifications

Item	Standard
Subthrottle Sensor: Input Voltage Output Voltage Resistance Exhaust Butterfly Valve Actuator Sensor: Input Voltage Output Voltage Resistance Immobilizer Antenna (Equipped Models): Resistance Exhaust Butterfly Valve Actuator: Resistance Subthrottle Valve Actuator: Resistance Input Voltage Oxygen Sensor (Equipped Models): Output Voltage (Rich) Output Voltage (Lean) Heater Resistance	DC 4.75 ~ 5.25 V DC 1.08 ~ 1.12 V at subthrottle valve full close position DC 4.2 ~ 4.4 V at subthrottle valve full open position (for reference) 4 ~ 6 kΩ DC 4.75 ~ 5.25 V DC 3.46 ~ 3.76 V at pulley original position 4 ~ 6 kΩ About 3.0 ~ 4.6 Ω 5 ~ 200 Ω (for reference) About 5.2 ~ 7.8 Ω About DC 11.5 ~ 13.5 V DC 0.7 V or more DC 0.2 V or less 11.7 ~ 14.5 Ω at 20°C (68°F)
Throttle Grip and Cables Throttle Grip Free Play	2 ~ 3 mm (0.08 ~ 0.12 in.)
Air Cleaner Element	Viscous paper element

3-20 FUEL SYSTEM (DFI)

Special Tools and Sealant

Oil Pressure Gauge, 5 kgf/cm²:

57001-125

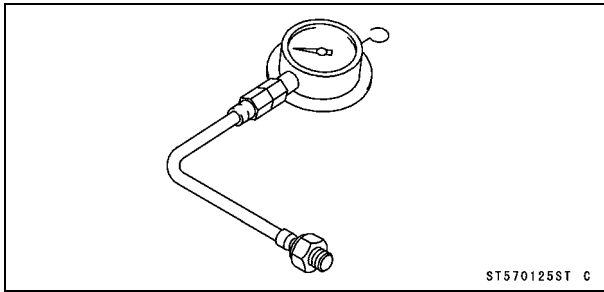

ST570125ST C

Throttle Sensor Setting Adapter #1:

57001-1400

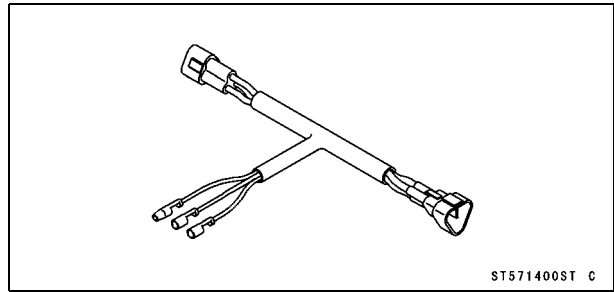

ST571400ST C

Carburetor Drain Plug Wrench, Hex 3:

57001-1269

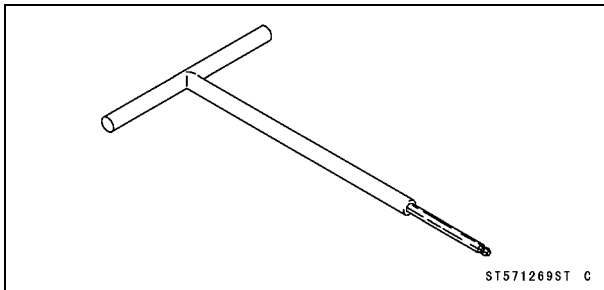

ST571269ST C

Peak Voltage Adapter:

57001-1415

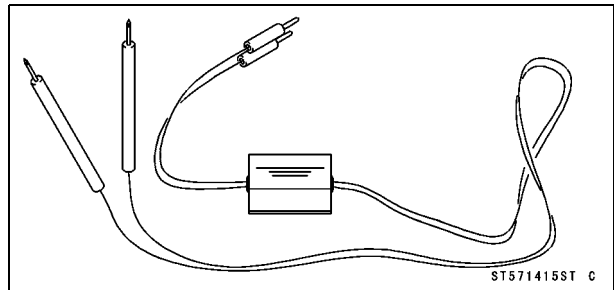

ST571415ST C

Fork Oil Level Gauge:

57001-1290

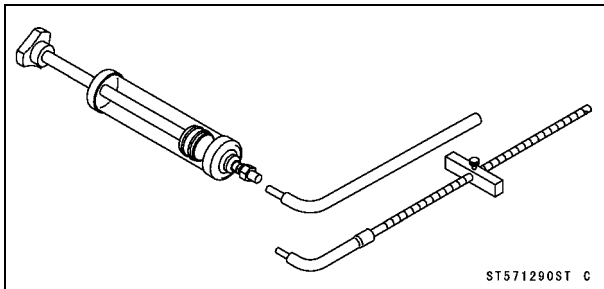

ST571290ST C

Needle Adapter Set:

57001-1457

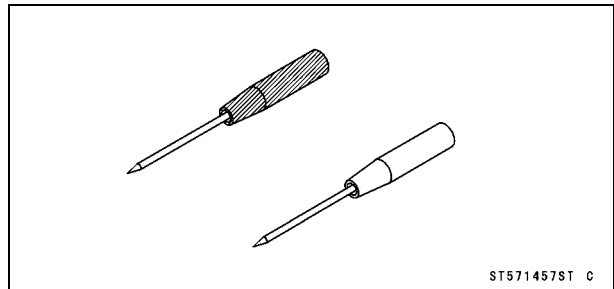

ST571457ST C

Vacuum Gauge:

57001-1369

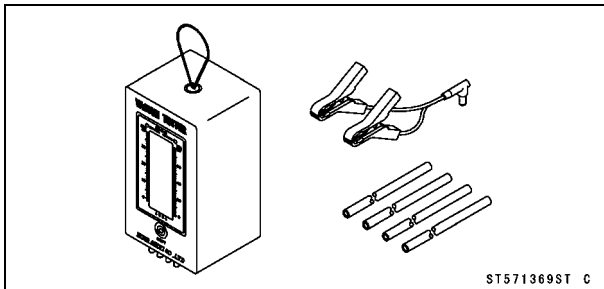

ST571369ST C

Throttle Sensor Setting Adapter:

57001-1538

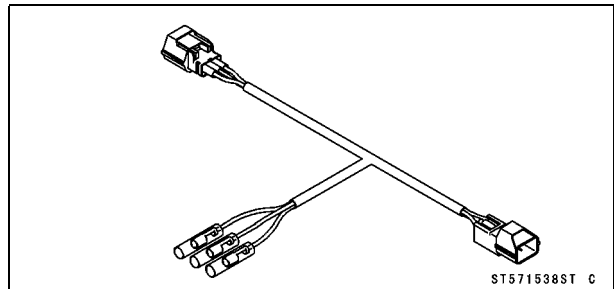

ST571538ST C

Hand Tester:

57001-1394

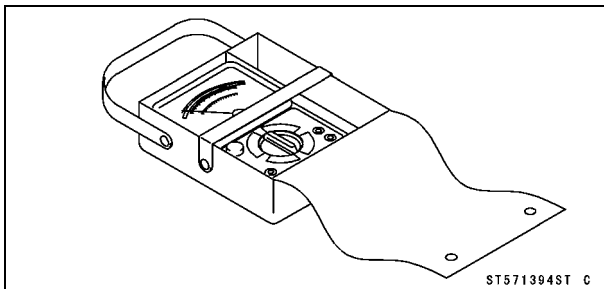

ST571394ST C

Fuel Pressure Gauge Adapter:

57001-1593

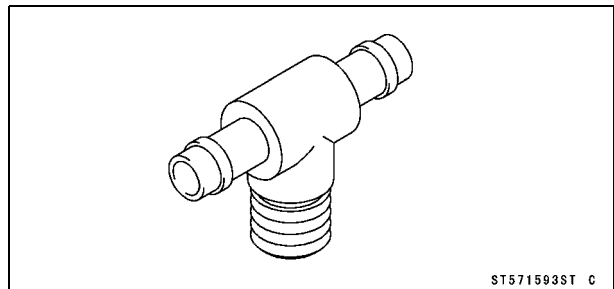

ST571593ST C

Special Tools and Sealant

Fuel Hose:
57001-1607

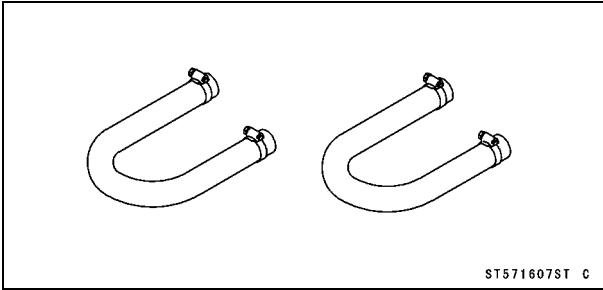

Liquid Gasket, TB1211:
56019-120

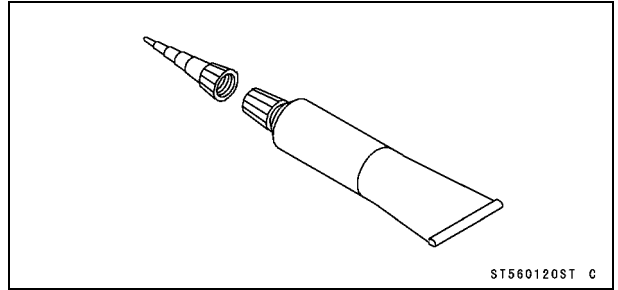

Measuring Adapter:
57001-1700

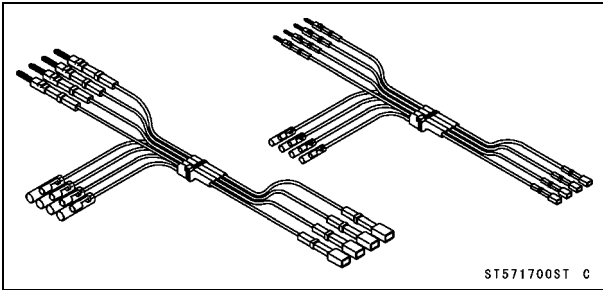

3-22 FUEL SYSTEM (DFI)

DFI Servicing Precautions

DFI Servicing Precautions

There are a number of important precautions that should be followed servicing the DFI system.

- This DFI system is designed to be used with a 12 V sealed battery as its power source. Do not use any other battery except for a 12 V sealed battery as a power source.
- Do not reverse the battery cable connections. This will damage the ECU.
- To prevent damage to the DFI parts, do not disconnect the battery cables or any other electrical connections when the ignition switch is ON, or while the engine is running.
- Take care not to short the leads that are directly connected to the battery positive (+) terminal to the chassis ground.
- When charging, remove the battery from the motorcycle. This is to prevent ECU damage by excessive voltage.
- Whenever the DFI electrical connections are to be disconnected, first turn off the ignition switch, and disconnect the battery (–) terminal. Do not pull the lead, only the connector. Conversely, make sure that all the DFI electrical connections are firmly reconnected before starting the engine.
- Connect these connectors until they click [A].

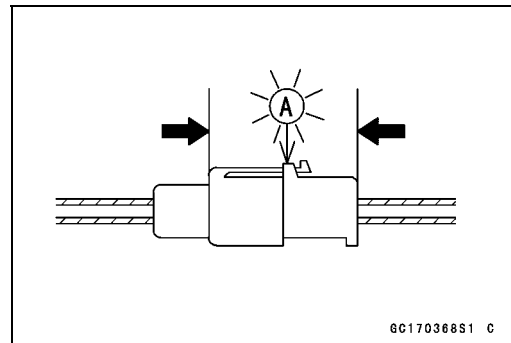

- Do not turn the ignition switch ON while any of the DFI electrical connectors are disconnected. The ECU memorizes service codes.
- Do not spray water on the electrical parts, DFI parts, connectors, leads and wiring.
- If a transceiver is installed on the motorcycle, make sure that the operation of the DFI system is not influenced by electric wave radiated from the antenna. Check operation of the system with the engine at idle. Locate the antenna as far as possible away from the ECU.
- When any fuel hose is disconnected, do not turn on the ignition switch. Otherwise, the fuel pump will operate and fuel will spout from the fuel hose.
- Do not operate the fuel pump if the pump is completely dry. This is to prevent pump seizure.
- Before removing the fuel system parts, blow the outer surfaces of these parts clean with compressed air.
- When any fuel hose is disconnected, fuel may spout out by residual pressure in the fuel line. Cover the hose joint with a piece of clean cloth to prevent fuel spillage.
- When installing the fuel hoses, avoid sharp bending, kinking, flattening or twisting, and run the fuel hoses with a minimum of bending so that the fuel flow will not be obstructed.
- Run the hoses according to Cable, Wire, and Hose Routing section in the Appendix chapter.
- To prevent corrosion and deposits in the fuel system, do not add to fuel any fuel antifreeze chemicals.

DFI Servicing Precautions

○If the motorcycle is not properly handled, the high pressure inside the fuel line can cause fuel to leak or the hose to burst. Remove the fuel tank (see Fuel Tank Removal) and check the fuel hose [A].

★Replace the fuel hose if any fraying, cracks or bulges are noticed.



○To maintain the correct fuel/air mixture (F/A), there must be no intake air leaks in the DFI system. Be sure to install the oil filler plug [A] after filling the engine oil.

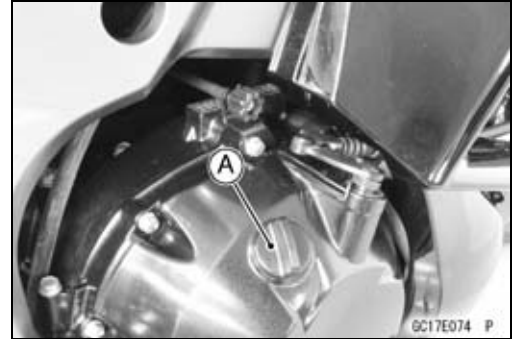

3-24 FUEL SYSTEM (DFI)

Troubleshooting the DFI System

The warning indicator light (LED) [A] is used for the FI indicator, immobilizer indicator (equipped models) and oil pressure warning indicator.

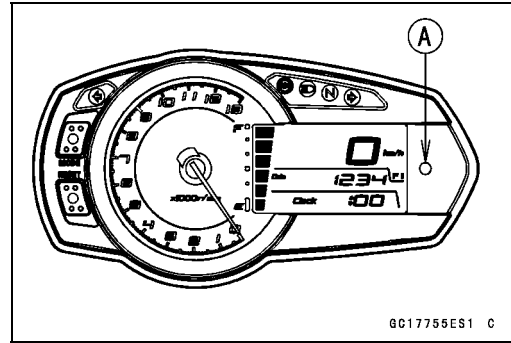

Outline

When a problem occurs with DFI system, the warning indicator light (LED) [A] and FI warning symbol [B] blinks to alert the rider. In addition, the condition of the problem is stored in the memory of the ECU. For models equipped with an immobilizer system, the warning indicator light (LED) and immobilizer warning symbol [C] blinks, when a problem occurs in the system.

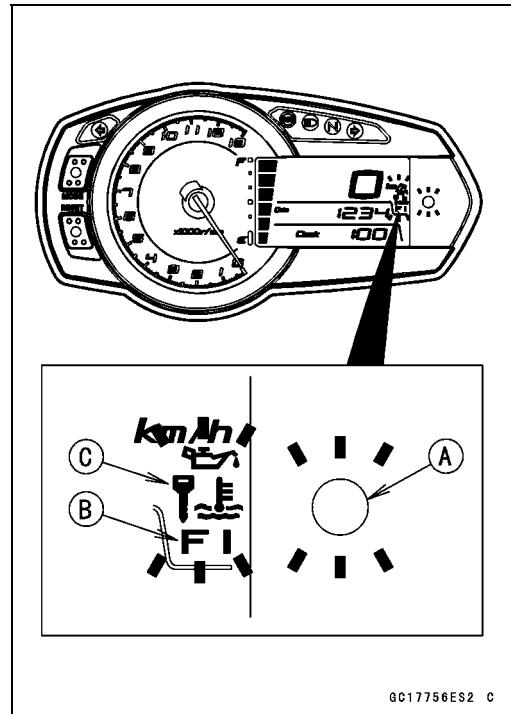

With the engine stopped and turned in the self-diagnosis mode, the service code [A] is displayed on the LCD (Liquid Crystal Display) by the number of two digits.

If the problem is with the following parts, the ECU can not recognize these problem. Therefore, the warning indicator light (LED), FI and/or immobilizer warning symbols do not blinks, and service code is not displayed.

- LCD for Meter Unit
- Fuel Pump
- Fuel Pump Relay
- Fuel Injectors
- Stick Coil Secondary Wiring and Ground Wiring
- ECU Main Relay
- ECU Power Source Wiring and Ground Wiring

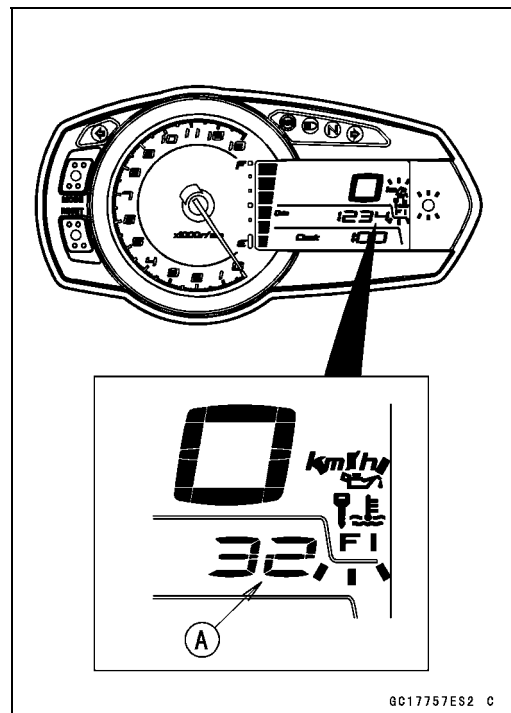

Troubleshooting the DFI System

When the service code [A] is displayed, for first ask the rider about the conditions [B] of trouble, and then start to determine the cause [C] of problem.

As a pre-diagnosis inspection, check the ECU for ground and power supply, the fuel line for no fuel leaks, and for correct pressure. The pre-diagnosis items are not indicated by the warning indicator light (LED) and FI warning symbol.

Don't rely solely on the DFI self-diagnosis function, use common sense.

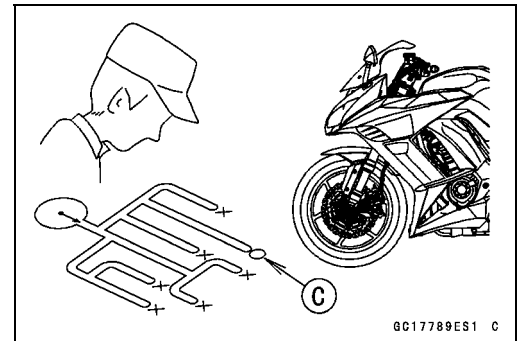
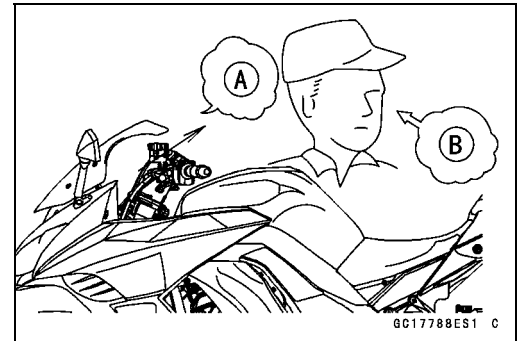

Even when the DFI system is operating normally, the warning indicator light (LED) and FI warning symbol may blink under strong electrical interference. Additional measures are not required. Turn the ignition switch OFF to stop the indicator light and symbol.

If the warning indicator light (LED) and FI warning symbol of the motorcycle brought in for repair still blinks, check the service code.

When the repair has been done, the FI warning symbol goes off. But the service codes stored in memory of the ECU are not erased to preserve the problem history. The problem history can be referred using the KDS (Kawasaki Diagnostic System) when solving unstable problems.

When the motorcycle is down, the vehicle-down sensor operates and the ECU shuts off the fuel pump relay, fuel injectors and ignition system. The ignition switch is left ON. If the starter button is pushed, the electric starter turns but the engine does not start. When the starter button is pushed, the warning indicator light (LED) and FI warning symbol blink but the service code is not displayed. To start the engine again, raise the motorcycle, turn the ignition switch OFF, and then ON.

Much of the DFI system troubleshooting work consists of confirming continuity of the wiring. The DFI parts are assembled and adjusted with precision, and it is impossible to disassemble or repair them.

3-26 FUEL SYSTEM (DFI)

Troubleshooting the DFI System

- When checking the DFI parts, use a digital meter which can be read two decimal place voltage or resistance.
- The DFI part connectors [A] have seals [B], including the ECU. When measuring the input or output voltage with the connector joined, use the needle adapter set [C]. Insert the needle adapter inside the seal until the needle adapter reaches the terminal.

Special Tool - Needle Adapter Set: 57001-1457

NOTICE

Insert the needle adapter straight along the terminal in the connector to prevent short-circuit between terminals.

- Make sure that measuring points are correct in the connector, noting the position of the lock [D] and the lead color before measurement. Do not reverse connections of a digital meter.
- Be careful not to short-circuit the leads of the DFI or electrical system parts by contact between adapters.
- Turn the ignition switch ON and measure the voltage with the connector joined.

NOTICE

Incorrect, reverse connection or short circuit by needle adapters could damage the DFI or electrical system parts.

- After measurement, remove the needle adapters and apply silicone sealant to the seals [A] of the connector [B] for waterproofing.

Sealant - Liquid Gasket, TB1211: 56019-120

- Always check battery condition before replacing the DFI parts. A fully charged battery is a must for conducting accurate tests of the DFI system.
- Trouble may involve one or in some cases all items. Never replace a defective part without determining what CAUSED the problem. If the problem was caused by some other item or items, they too must be repaired or replaced, or the new replacement part will soon fail again.
- Measure coil winding resistance when the DFI part is cold (at room temperature).
- Make sure all connectors in the circuit are clean and tight, and examine leads for signs of burning, fraying, short, etc. Deteriorated leads and bad connections can cause reappearance of problems and unstable operation of the DFI system.
- ★ If any wiring is deteriorated, replace the wiring.

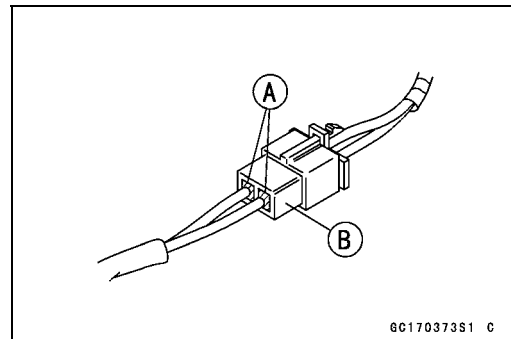
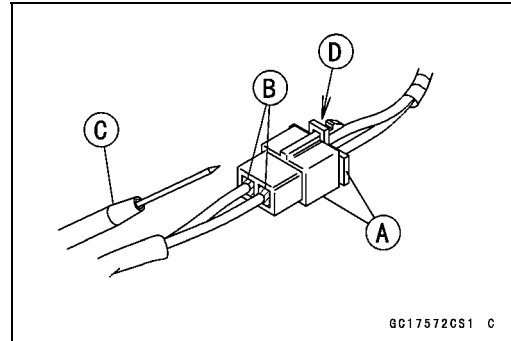

Troubleshooting the DFI System

- Pull each connector [A] apart and inspect it for corrosion, dirt, and damage.
- ★ If the connector is corroded or dirty, clean it carefully. If it is damaged, replace it. Connect the connectors securely.
- Check the wiring for continuity.
- Use the wiring diagram to find the ends of the lead which is suspected of being a problem.
- Connect the hand tester between the ends of the leads.

Special Tool - Hand Tester: 57001-1394

- Set the tester to the $\times 1 \Omega$ range, and read the tester.
- ★ If the tester does not read 0Ω , the lead is defective. Replace the lead or the main harness or the subharness.
- If both ends of a harness [A] are far apart, ground [B] the one end [C], using a jumper lead [D] and check the continuity between the end [E] and the ground [F]. This enables to check a long harness for continuity. If the harness is open, repair or replace the harness.

- When checking a harness [A] for short circuit, open one end [B] and check the continuity between the other end [C] and ground [D]. If there is continuity, the harness has a short circuit to ground, and it must be repaired or replaced.

- Narrow down suspicious locations by repeating the continuity tests from the ECU connectors.
- ★ If no abnormality is found in the wiring or connectors, the DFI parts are the next likely suspects. Check the part, starting with input and output voltages. However, there is no way to check the ECU itself.
- ★ If an abnormality is found, replace the affected DFI part.
- ★ If no abnormality is found in the wiring, connectors, and DFI parts, replace the ECU.

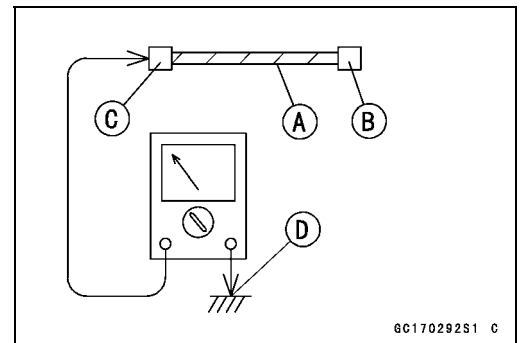
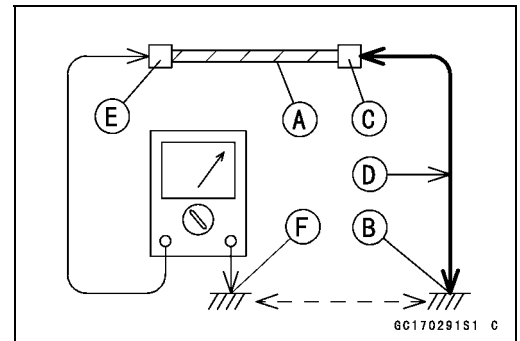
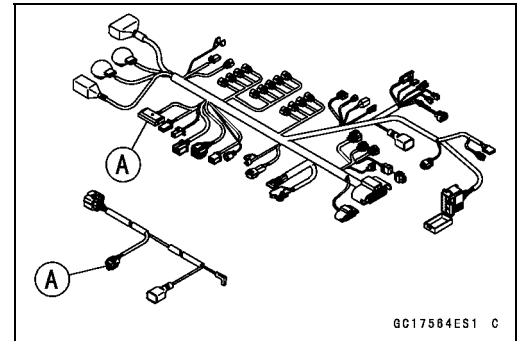

3-28 FUEL SYSTEM (DFI)

Troubleshooting the DFI System

DFI Diagnosis Flow Chart

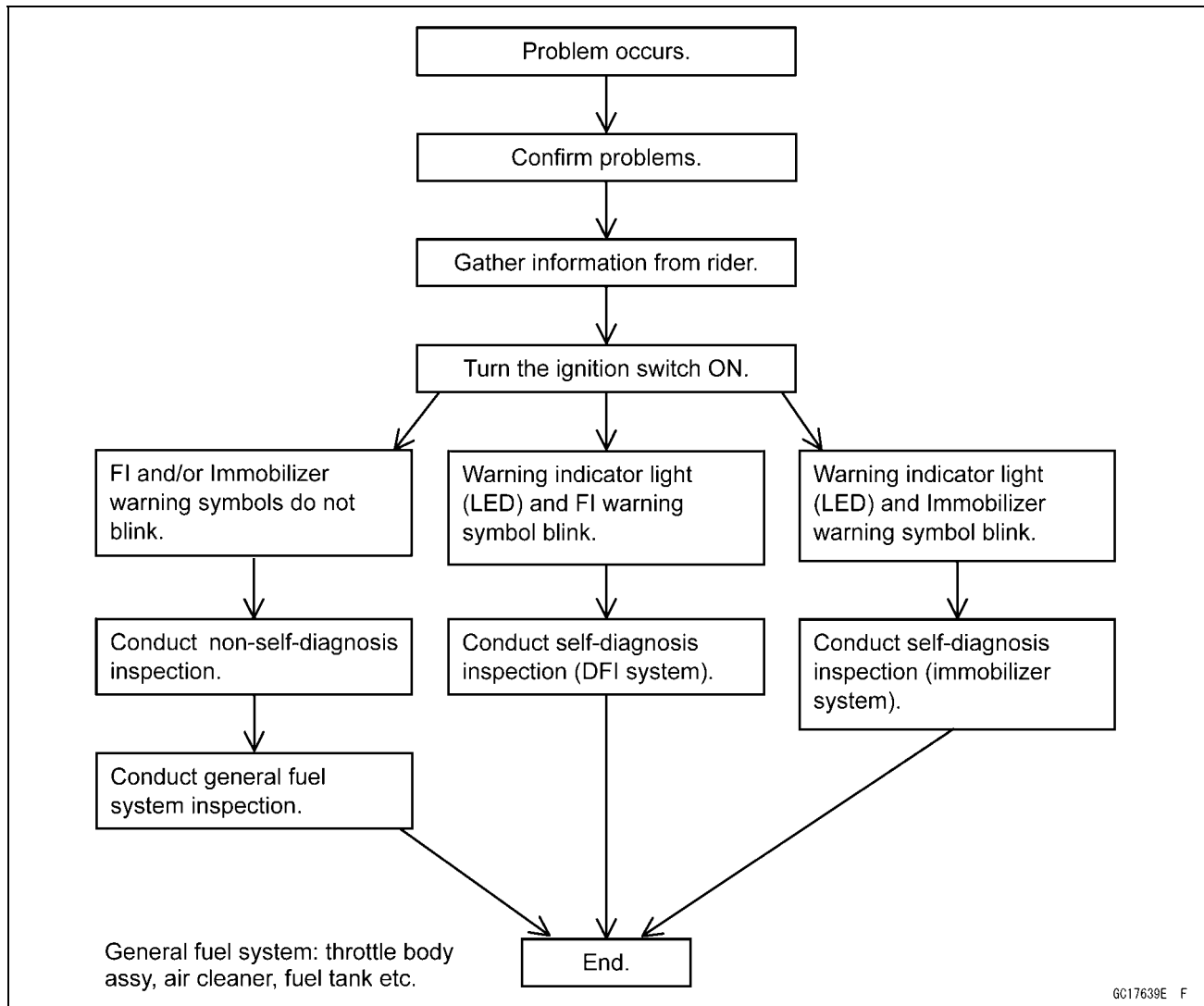

Inquiries to Rider

- Each rider reacts to problems in different ways, so it is important to confirm what kind of symptoms the rider has encountered.
- Try to find out exactly what problem occurred under exactly what conditions by asking the rider; knowing this information may help you reproduce the problem.
- The following sample diagnosis sheet will help prevent you from overlooking any areas, and will help you decide if it is a DFI system problem, or a general engine problem.

Troubleshooting the DFI System

Sample Diagnosis Sheet

Rider name:	Registration No. (license plate No.):	Year of initial registration:
Model:	Engine No.:	Frame No.:
Date problem occurred:		Mileage:
Environment when problem occurred.		
Weather	<input type="checkbox"/> fine, <input type="checkbox"/> cloudy, <input type="checkbox"/> rain, <input type="checkbox"/> snow, <input type="checkbox"/> always, <input type="checkbox"/> other:	
Temperature	<input type="checkbox"/> hot, <input type="checkbox"/> warm, <input type="checkbox"/> cold, <input type="checkbox"/> very cold, <input type="checkbox"/> always, <input type="checkbox"/> other:	
Problem frequency	<input type="checkbox"/> chronic, <input type="checkbox"/> often, <input type="checkbox"/> once	
Road	<input type="checkbox"/> street, <input type="checkbox"/> highway, <input type="checkbox"/> mountain road (<input type="checkbox"/> uphill, <input type="checkbox"/> downhill), <input type="checkbox"/> bumpy, <input type="checkbox"/> pebble	
Altitude	<input type="checkbox"/> normal, <input type="checkbox"/> high (about 1 000 m or more)	
Motorcycle conditions when problem occurred.		
Warning indicator light (LED)	<input type="checkbox"/> Starts blinking about 3 seconds after from ignition switch ON, and goes off after engine pressure becomes high enough (with engine running).	
	<input type="checkbox"/> Starts blinking about 3 seconds after from ignition switch ON, and the FI warning symbol on the LCD starts blinking (DFI system problem).	
	<input type="checkbox"/> Starts blinking about 3 seconds after from ignition switch ON, and the immobilizer warning symbol on the LCD starts blinking (immobilizer system problem).	
	<input type="checkbox"/> Starts blinking about 3 seconds after from ignition switch ON, and about 10 seconds after, the FI warning symbol on the LCD starts blinking (ECU communication error).	
	<input type="checkbox"/> Does not blink about 3 seconds after ignition switch ON.	
	<input type="checkbox"/> light up (ECU or meter unit replace).	
Starting difficulty	<input type="checkbox"/> starter motor not rotating.	
	<input type="checkbox"/> starter motor rotating but engine do not turn over.	
	<input type="checkbox"/> starter motor and engine do not turn over.	
	<input type="checkbox"/> no fuel flow (<input type="checkbox"/> no fuel in tank, <input type="checkbox"/> no fuel pump sound).	
	<input type="checkbox"/> no spark.	
	<input type="checkbox"/> other:	
Engine stalls	<input type="checkbox"/> right after starting.	
	<input type="checkbox"/> when opening throttle grip.	
	<input type="checkbox"/> when closing throttle grip.	
	<input type="checkbox"/> when moving off.	
	<input type="checkbox"/> when stopping the motorcycle.	
	<input type="checkbox"/> when cruising.	
<input type="checkbox"/> other:		

3-30 FUEL SYSTEM (DFI)

Troubleshooting the DFI System

Poor running at low speed	<input type="checkbox"/> very low idle speed, <input type="checkbox"/> very high idle speed, <input type="checkbox"/> rough idle speed.
	<input type="checkbox"/> battery voltage is low (charge the battery).
	<input type="checkbox"/> spark plug loose (tighten it).
	<input type="checkbox"/> spark plug dirty, broken, or gap maladjusted (remedy it).
	<input type="checkbox"/> backfiring.
	<input type="checkbox"/> afterfiring.
	<input type="checkbox"/> hesitation when acceleration.
	<input type="checkbox"/> engine oil viscosity too high.
	<input type="checkbox"/> brake dragging.
	<input type="checkbox"/> engine overheating.
	<input type="checkbox"/> clutch slipping.
	<input type="checkbox"/> other:
Poor running or no power at high speed	<input type="checkbox"/> spark plug loose (tighten it).
	<input type="checkbox"/> spark plug dirty, broken, or gap maladjusted (remedy it).
	<input type="checkbox"/> spark plug incorrect (replace it).
	<input type="checkbox"/> knocking (fuel poor quality or incorrect, → use high-octane gasoline).
	<input type="checkbox"/> brake dragging.
	<input type="checkbox"/> clutch slipping.
	<input type="checkbox"/> engine overheating.
	<input type="checkbox"/> engine oil level too high.
	<input type="checkbox"/> engine oil viscosity too high.
	<input type="checkbox"/> other:

DFI System Troubleshooting Guide

NOTE

- *This is not an exhaustive list, giving every possible cause for each problem listed. It is meant simply as a rough guide to assist the troubleshooting for some of the more common difficulties in DFI system.*
- *The ECU may be involved in the DFI electrical and ignition system troubles. If these parts and circuits are checked out good, be sure to check the ECU for ground and power supply. If the ground and power supply are checked good, replace the ECU.*

Engine Won't Turn Over

Symptoms or Possible Causes	Actions (chapter)
Neutral, starter lockout or sidestand switch trouble	Inspect each switch (see chapter 16).
Immobilizer system trouble	Inspect (see chapter 3).
Vehicle-down sensor operated	Turn ignition switch OFF (see chapter 3).
Vehicle-down sensor trouble	Inspect (see chapter 3).
Crankshaft sensor trouble	Inspect (see chapter 16).
Stick coil shorted or not in good contact	Inspect or Reinstall (see chapter 16).
Stick coil trouble	Inspect (see chapter 16).
Spark plug dirty, broken or gap maladjusted	Inspect and replace (see chapter 2).
Spark plug incorrect	Replace it with the correct plug (see chapter 2).
ECU ground and power supply trouble	Inspect (see chapter 3).
ECU trouble	Inspect (see chapter 3).
No or little fuel in tank	Supply fuel (see Owner's Manual).
Fuel injector trouble	Inspect and replace (see chapter 3).
Fuel pump not operating	Inspect (see chapter 3).
Fuel pump relay trouble	Inspect and replace (see chapter 16).
Fuel filter or pump screen clogged	Inspect and replace fuel pump (see chapter 3).
Fuel pressure regulator trouble	Inspect fuel pressure and replace fuel pump (see chapter 3).
Fuel line clogged	Inspect and repair (see chapter 3).

Poor Running at Low Speed

Symptoms or Possible Causes	Actions (chapter)
Spark weak:	
Stick coil shorted or not in good contact	Inspect or reinstall (see chapter 16).
Stick coil trouble	Inspect (see chapter 16).
Spark plug dirty, broken or gap maladjusted	Inspect and replace (see chapter 2).
Spark plug incorrect	Replace it with the correct plug (see chapter 2).
ECU trouble	Inspect (see chapter 3).
Fuel/air mixture incorrect:	
Little fuel in tank	Supply fuel (see Owner's Manual).
Air cleaner clogged, poorly sealed, or missing	Clean element or inspect sealing (see chapter 2).
Air duct loose	Reinstall (see chapter 3).
Throttle body assy holder loose	Reinstall (see chapter 3).
Throttle body assy dust seal damage	Replace (see chapter 3).
Fuel injector O-ring damage	Replace (see chapter 3).
Fuel filter or pump screen clogged	Inspect and replace fuel pump (see chapter 3).

3-32 FUEL SYSTEM (DFI)

DFI System Troubleshooting Guide

Symptoms or Possible Causes	Actions (chapter)
Fuel pressure regulator trouble	Inspect fuel pressure and replace fuel pump (see chapter 3).
Fuel line clogged	Inspect and repair (see chapter 3).
Intake air pressure sensor #1 trouble	Inspect (see chapter 3).
Intake air pressure sensor #2 trouble	Inspect (see chapter 3).
Water temperature sensor trouble	Inspect (see chapter 3).
Intake air temperature sensor trouble	Inspect (see chapter 3).
Main throttle sensor trouble	Inspect (see chapter 3).
Subthrottle sensor trouble	Inspect (see chapter 3).
Subthrottle valve actuator trouble	Inspect (see chapter 3).
Unstable (rough) idling:	
Fuel pressure too low or too high	Inspect (see chapter 3).
Fuel injector trouble	Inspect (see chapter 3).
Main throttle sensor trouble	Inspect (see chapter 3).
Subthrottle sensor trouble	Inspect (see chapter 3).
Subthrottle valve actuator trouble	Inspect (see chapter 3).
Engine vacuum not synchronizing	Inspect and adjust (see chapter 2).
Intake air pressure sensor #1 trouble	Inspect (see chapter 3).
Intake air pressure sensor #2 trouble	Inspect (see chapter 3).
Water temperature sensor trouble	Inspect (see chapter 3).
Intake air temperature sensor trouble	Inspect (see chapter 3).
Engine stalls easily:	
Spark plug dirty, broken or gap maladjusted	Inspect and replace (see chapter 2).
Stick coil trouble	Inspect (see chapter 16).
Main throttle sensor trouble	Inspect (see chapter 3).
Subthrottle sensor trouble	Inspect (see chapter 3).
Subthrottle valve actuator trouble	Inspect (see chapter 3).
Intake air pressure sensor #1 trouble	Inspect (see chapter 3).
Intake air pressure sensor #2 trouble	Inspect (see chapter 3).
Water temperature sensor trouble	Inspect (see chapter 3).
Intake air temperature sensor trouble	Inspect (see chapter 3).
Fuel pump trouble	Inspect (see chapter 3).
Fuel injector trouble	Inspect (see chapter 3).
Fuel pressure too low or too high	Inspect (see chapter 3).
Fuel pressure regulator trouble	Inspect fuel pressure and replace fuel pump (see chapter 3).
Fuel line clogged	Inspect and repair (see chapter 3).
Poor acceleration:	
Fuel pressure too low	Inspect (see chapter 3).
Water or foreign matter in fuel	Change fuel. Inspect and clean fuel system (see chapter 3).
Fuel filter or pump screen clogged	Inspect and replace fuel pump (see chapter 3).
Fuel pump trouble	Inspect (see chapter 3).
Fuel injector trouble	Inspect (see chapter 3).
Main throttle sensor trouble	Inspect (see chapter 3).

DFI System Troubleshooting Guide

Symptoms or Possible Causes	Actions (chapter)
Subthrottle sensor trouble	Inspect (see chapter 3).
Subthrottle valve actuator trouble	Inspect (see chapter 3).
Intake air pressure sensor #1 trouble	Inspect (see chapter 3).
Intake air pressure sensor #2 trouble	Inspect (see chapter 3).
Water temperature sensor trouble	Inspect (see chapter 3).
Intake air temperature sensor trouble	Inspect (see chapter 3).
Spark plug dirty, broken or gap maladjusted	Inspect and replace (see chapter 2).
Stick coil trouble	Inspect (see chapter 16).
Stumble:	
Fuel pressure too low	Inspect (see chapter 3).
Fuel injector trouble	Inspect (see chapter 3).
Main throttle sensor trouble	Inspect (see chapter 3).
Subthrottle sensor trouble	Inspect (see chapter 3).
Subthrottle valve actuator trouble	Inspect (see chapter 3).
Intake air pressure sensor #1 trouble	Inspect (see chapter 3).
Intake air pressure sensor #2 trouble	Inspect (see chapter 3).
Water temperature sensor trouble	Inspect (see chapter 3).
Intake air temperature sensor trouble	Inspect (see chapter 3).
Surge:	
Unstable fuel pressure	Fuel pressure regulator trouble (Inspect and replace fuel pump) or kinked fuel line (Inspect and replace fuel pump) (see chapter 3).
Fuel injector trouble	Inspect (see chapter 3).
Water temperature sensor trouble	Inspect (see chapter 3).
Backfiring when deceleration:	
Spark plug dirty, broken or gap maladjusted	Inspect and replace (see chapter 2).
Fuel pressure too low	Inspect (see chapter 3).
Fuel pump trouble	Inspect (see chapter 3).
Main throttle sensor trouble	Inspect (see chapter 3).
Subthrottle sensor trouble	Inspect (see chapter 3).
Subthrottle valve actuator trouble	Inspect (see chapter 3).
Intake air pressure sensor #1 trouble	Inspect (see chapter 3).
Intake air pressure sensor #2 trouble	Inspect (see chapter 3).
Water temperature sensor trouble	Inspect (see chapter 3).
Intake air temperature sensor trouble	Inspect (see chapter 3).
Air switching valve trouble	Inspect and replace (see chapter 16).
Air suction valve trouble	Inspect and replace (see chapter 5).
After fire:	
Spark plug burned or gap maladjusted	Replace (see chapter 2).
Fuel injector trouble	Inspect (see chapter 3).
Intake air pressure sensor #1 trouble	Inspect (see chapter 3).
Intake air pressure sensor #2 trouble	Inspect (see chapter 3).
Water temperature sensor trouble	Inspect (see chapter 3).
Intake air temperature sensor trouble	Inspect (see chapter 3).

3-34 FUEL SYSTEM (DFI)

DFI System Troubleshooting Guide

Symptoms or Possible Causes	Actions (chapter)
Other:	
Intermittent any DFI fault and its recovery	Check that DFI connectors are clean and tight, and examine leads for signs of burning or fraying (see chapter 3).

Poor Running or No Power at High Speed

Symptoms or Possible Causes	Actions (chapter)
Firing incorrect:	
Stick coil shorted or not in good contact	Inspect or Reinstall (see chapter 16).
Stick coil trouble	Inspect (see chapter 16).
Spark plug dirty, broken or gap maladjusted	Inspect and replace (see chapter 2).
Spark plug incorrect	Replace it with the correct plug (see chapter 2).
ECU trouble	Inspect (see chapter 3).
Fuel/air mixture incorrect:	
Air cleaner clogged, poorly sealed, or missing	Clean element or inspect sealing (see chapter 2).
Air duct loose	Reinstall (see chapter 3).
Throttle body assy holder loose	Reinstall (see chapter 3).
Throttle body assy dust seal damage	Replace (see chapter 3).
Water or foreign matter in fuel	Change fuel. Inspect and clean fuel system (see chapter 3).
Fuel injector O-ring damage	Replace (see chapter 3).
Fuel injector clogged	Inspect and repair (see chapter 3).
Fuel line clogged	Inspect and repair (see chapter 3).
Fuel pump operates intermittently and often DFI fuse blows.	Fuel pump bearings may wear. Replace the fuel pump (see chapter 3).
Fuel pump trouble	Inspect (see chapter 3).
Intake air pressure sensor #1 trouble	Inspect (see chapter 3).
Intake air pressure sensor #2 trouble	Inspect (see chapter 3).
Cracked or obstructed intake air pressure sensor hose	Inspect and repair or replace (see chapter 3).
Water temperature sensor trouble	Inspect (see chapter 3).
Intake air temperature sensor trouble	Inspect (see chapter 3).
Main throttle sensor trouble	Inspect (see chapter 3).
Subthrottle sensor trouble	Inspect (see chapter 3).
Subthrottle valve actuator trouble	Inspect (see chapter 3).
Knocking:	
Fuel poor quality or incorrect	Fuel change (Use the gasoline recommended in the Owner's Manual).
Spark plug incorrect	Replace it with the correct plug (see chapter 2).
Stick coil trouble	Inspect (see chapter 16).
ECU trouble	Inspect (see chapter 3).
Engine vacuum not synchronizing	Inspect and adjust (see chapter 2).
Intake air pressure sensor #1 trouble	Inspect (see chapter 3).
Intake air pressure sensor #2 trouble	Inspect (see chapter 3).
Water temperature sensor trouble	Inspect (see chapter 3).

DFI System Troubleshooting Guide

Symptoms or Possible Causes	Actions (chapter)
Intake air temperature sensor trouble	Inspect (see chapter 3).
Miscellaneous:	
Subthrottle sensor trouble	Inspect (see chapter 3).
Subthrottle valve actuator trouble	Inspect (see chapter 3).
Speed sensor trouble	Inspect (see chapter 3).
Throttle valves will not fully open	Inspect throttle cables and lever linkage (see chapter 3).
Engine overheating - Water temperature sensor, crankshaft sensor or speed sensor trouble	(see Overheating of Troubleshooting Guide in chapter 17)
Air switching valve trouble	Inspect and replace (see chapter 16).
Air suction valve trouble	Inspect and replace (see chapter 5).
Exhaust Smokes Excessively:	
(Black smoke)	
Air cleaner element clogged	Clean element (see chapter 2).
Fuel pressure too high	Inspect (see chapter 3).
Fuel injector trouble	Inspect (see chapter 3).
Water temperature sensor trouble	Inspect (see chapter 3).
Intake air temperature sensor trouble	Inspect (see chapter 3).
(Brown smoke)	
Air duct loose	Reinstall (see chapter 3).
Fuel pressure too low	Inspect (see chapter 3).
Water temperature sensor trouble	Inspect (see chapter 3).
Intake air temperature sensor trouble	Inspect (see chapter 3).

3-36 FUEL SYSTEM (DFI)

Self-Diagnosis

The warning indicator light (LED) [A] is used for the FI indicator, immobilizer indicator (equipped models) and oil pressure warning indicator.

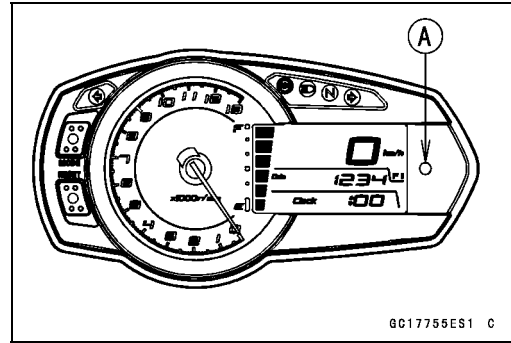

Self-diagnosis Outline

The self-diagnosis system has two modes and can be switched to another mode by operating the meter unit.

User Mode

The ECU notifies the rider of troubles in DFI system, ignition system and immobilizer system by blinking the warning indicator light (LED) [A], FI warning symbol [B] and immobilizer warning symbol [C] when DFI, ignition and immobilizer system parts are faulty, and initiates fail-safe function. In case of serious troubles ECU stops the injection and ignition operations.

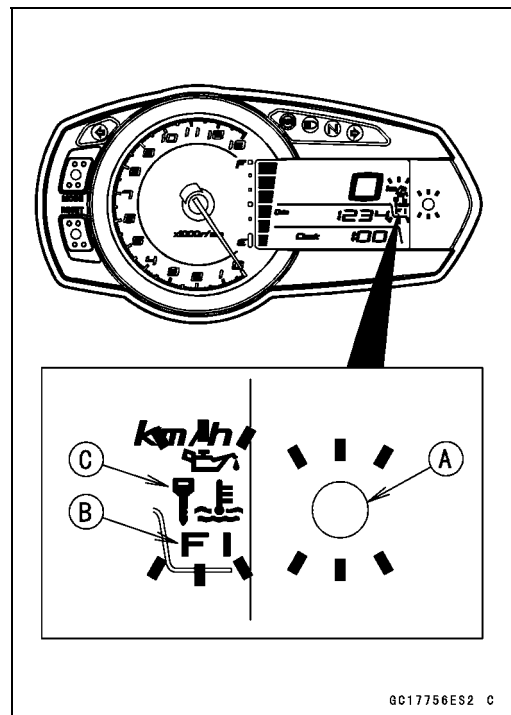

Self-Diagnosis

Dealer Mode

The LCD (Liquid Crystal Display) display the service code(s) [A] to show the problem(s) which the DFI system, ignition system and immobilizer system has at the moment of diagnosis.

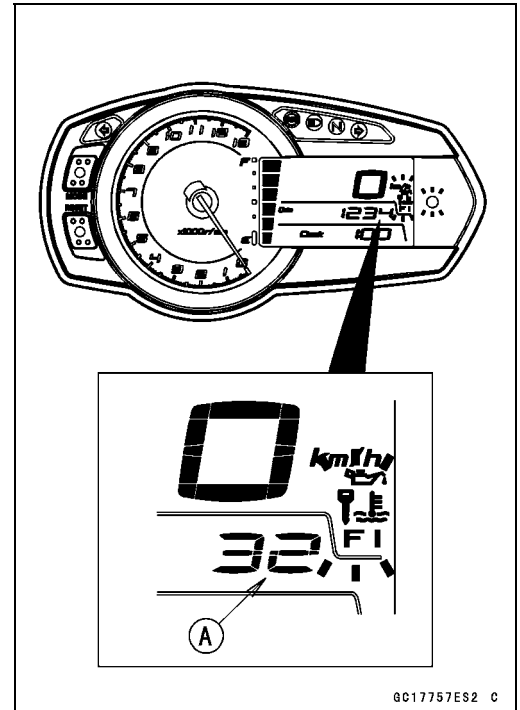

Self-diagnosis Procedures

- When a problem occurs with the DFI system and ignition system, the warning indicator light (LED) [A] and FI warning symbol [B] blink.
- For models equipped with an immobilizer system, when a problem occurs with the system, the warning indicator light (LED) and immobilizer warning symbol [C] blink.

NOTE

- Use a fully charged battery when conducting self-diagnosis. Otherwise, the light (LED) and symbol blink very slowly or do not blink.

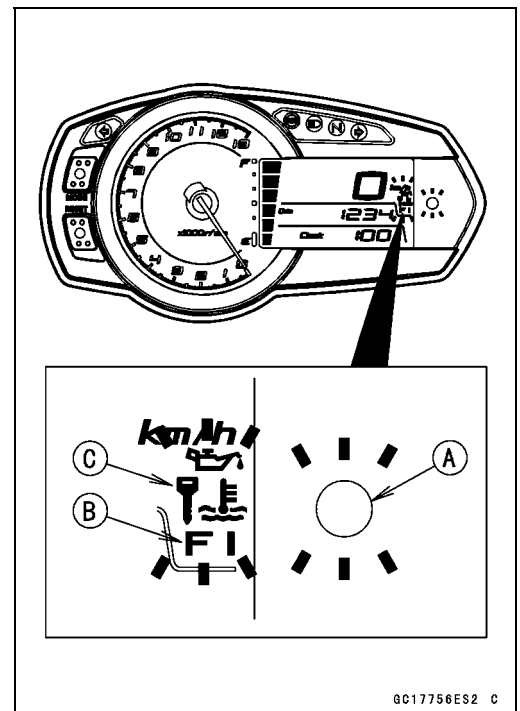

3-38 FUEL SYSTEM (DFI)

Self-Diagnosis

- Turn the ignition switch ON.
- Push the MODE button [A] to display the odometer.

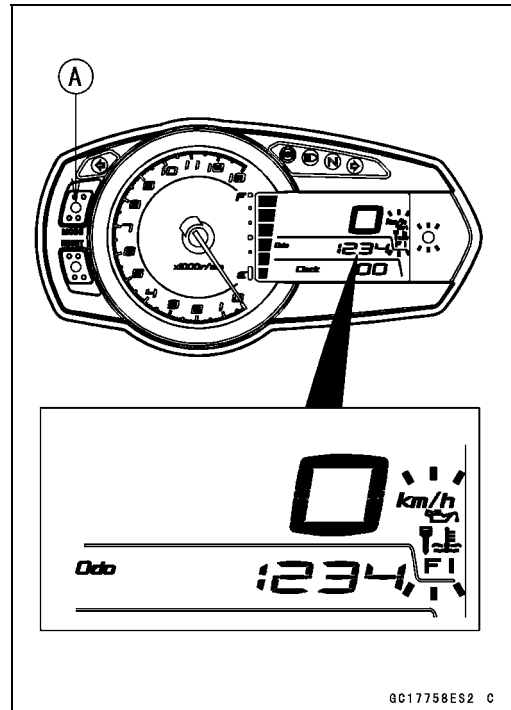

- Push the MODE button [A] for more than two seconds.
- The service code [B] is displayed on the LCD by the number of two digits.

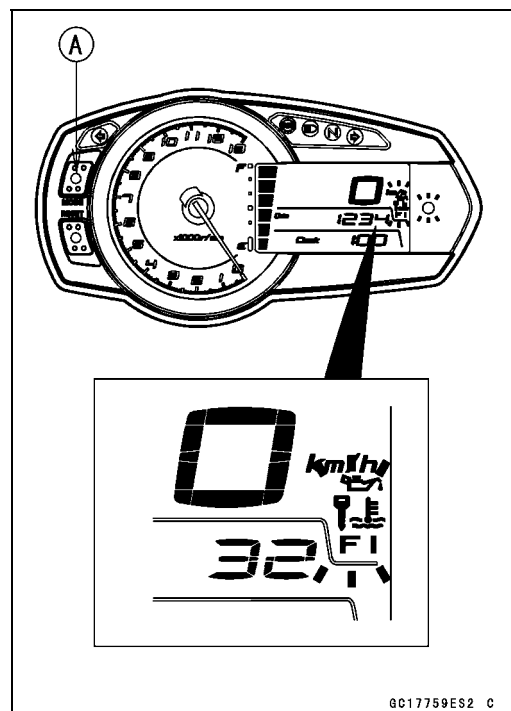

- Any of the following procedures ends self-diagnosis.
 - When the service code is displayed on the LCD, push the left button for more than two seconds.
 - When the ignition switch is turned OFF.

Self-Diagnosis

Self-Diagnosis Flow Chart

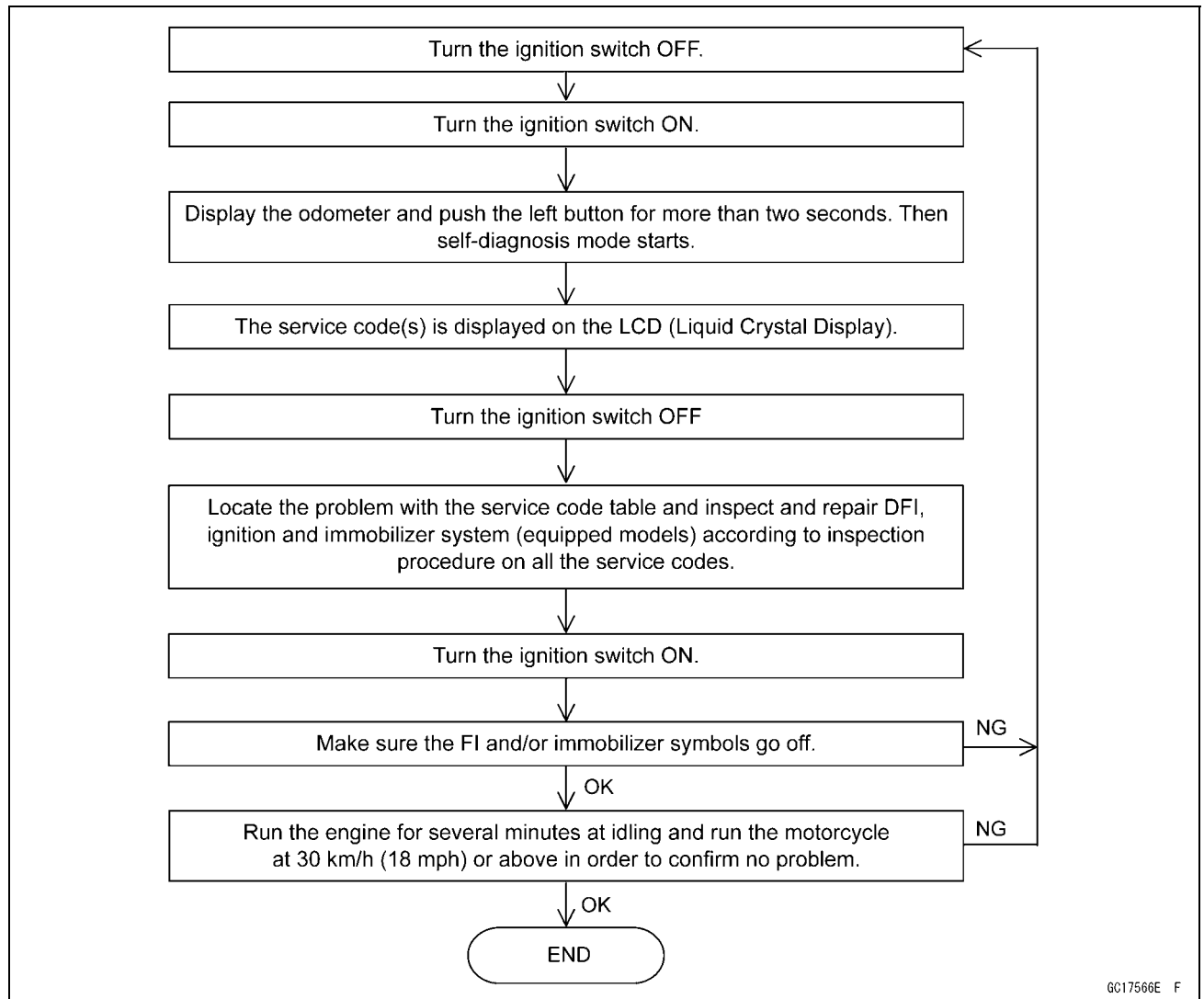

3-40 FUEL SYSTEM (DFI)

Self-Diagnosis

Service Code Reading

- The service code(s) is displayed on the LCD by the number of two digits.
- When there are a number of problems, all the service codes can be stored and the display will begin starting from the lowest number service code in the numerical order.
- Then after completing all codes, the display is repeated until the ignition switch is turned OFF or MODE button is pushed for more than two seconds.
- For example, if three problems occurred in the order of 56, 15, 35, the service codes are displayed (each two seconds) from the lowest number in the order listed as shown below. (15→35→56)→(15→35→56)→... (repeated)

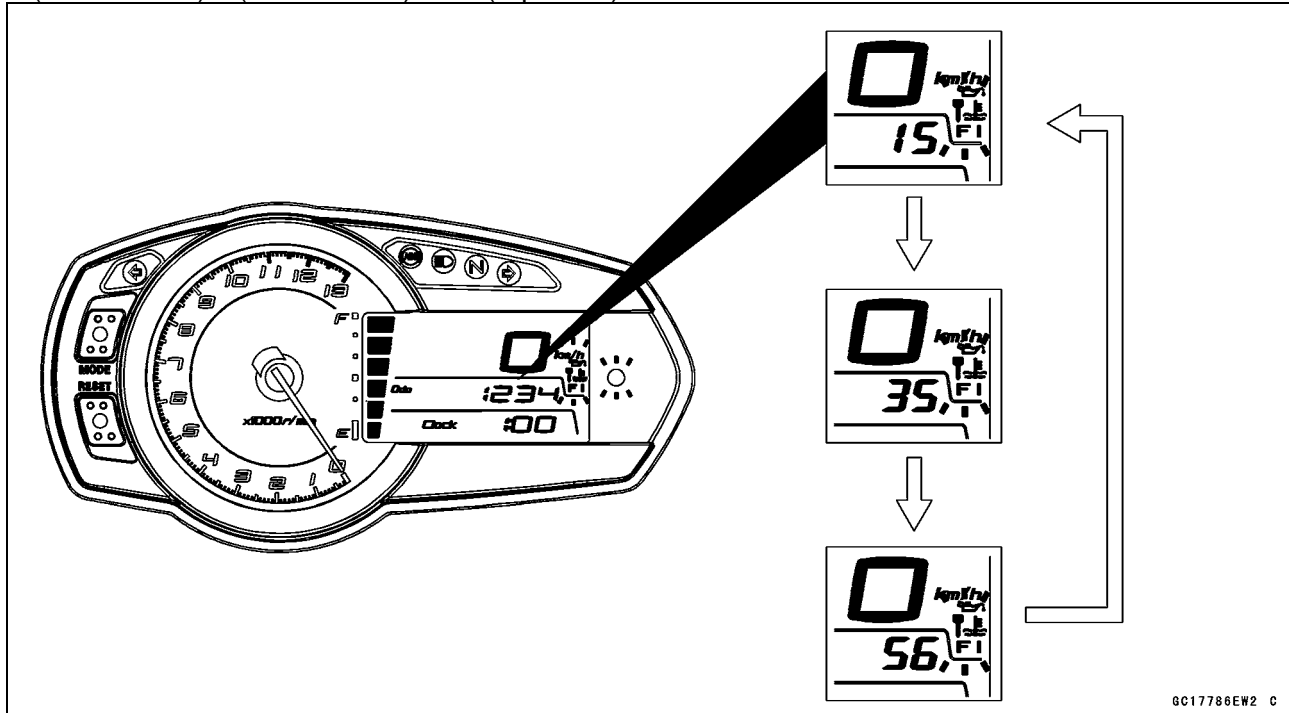

○If there is no problem or when the repair has been done, FI and/or immobilizer symbols go off and service code is not displayed.

Self-Diagnosis

Service Code Erasing

○When repair has been done, FI and/or immobilizer warning symbols go off and service code is not displayed.

★But the service codes stored in memory of the ECU are not erased to preserve the problem history. In this model, the problem history can not be erased.

Service Code Table

Service Code	Problems
11	Main throttle sensor malfunction, wiring open or short
12	Intake air pressure sensor #1 malfunction, wiring open or short
13	Intake air temperature sensor malfunction, wiring open or short
14	Water temperature sensor malfunction, wiring open or short
16	Intake air pressure sensor #2 malfunction, wiring open or short
21	Crankshaft sensor malfunction, wiring open or short
24 and 25	Speed sensor malfunction, wiring open or short First 24 is displayed and then 25, repeatedly
31	Vehicle-down sensor malfunction, wiring open or short
32	Subthrottle sensor malfunction, wiring open or short
33	Oxygen sensor inactivation, wiring open or short (Equipped Models)
34	Exhaust butterfly valve actuator sensor malfunction, wiring open or short
35	Immobilizer amplifier malfunction (Equipped Models)
36	Blank Key detection (Equipped Models)
39	ECU communication error
51	Stick coil #1 malfunction, wiring open or short
52	Stick coil #2 malfunction, wiring open or short
53	Stick coil #3 malfunction, wiring open or short
54	Stick coil #4 malfunction, wiring open or short
56	Radiator fan relay malfunction, wiring open or short
62	Subthrottle valve actuator malfunction, wiring open or short
63	Exhaust butterfly valve actuator malfunction, wiring open or short
64	Air switching valve malfunction, wiring open or short
67	Oxygen sensor heater malfunction, wiring open or short (Equipped Models)
94	Oxygen sensor malfunction, wiring open or short (Equipped Models)

Notes:

○The ECU may be involved in these problems. If all the parts and circuits checked out good, be sure to check the ECU for ground and power supply. If the ground and power supply are checked good, replace the ECU.

○When no service code is displayed, the electrical parts of the DFI system has no fault, and the mechanical parts of the DFI system and the engine are suspect.

3-42 FUEL SYSTEM (DFI)

Self-Diagnosis

Backups

○The ECU takes the following measures to prevent engine damage when the DFI, ignition or immobilizer system parts have troubles.

Service Codes	Parts	Output Signal Usable Range or Criteria	Backups by ECU
11	Main Throttle Sensor	Output Voltage 0.2 ~ 4.8 V	If the main throttle sensor system fails (the output voltage is out of the usable range, wiring short or open), the ECU locks ignition timing into the ignition timing at closed throttle position and sets the DFI in the D-J method (1).
12	Intake Air Pressure Sensor #1	Intake Air Pressure (Absolute) Pv = 100 ~ 900 mmHg	If the intake air pressure sensor #1 system fails (the signal is out of the usable range, wiring short or open), the ECU sets the DFI in the α-N method (2).
13	Intake Air Temperature Sensor	Intake Air Temperature Ta = - 47 ~ + 178°C	If the intake air temperature sensor system fails (the signal is out of the usable range, wiring short or open), the ECU sets Ta at 40°C.
14	Water Temperature Sensor	Water Temperature Tw = - 30 ~ + 120°C	If the water temperature sensor system fails (the signal is out of the usable range, wiring short or open), the ECU sets Tw at 80°C and radiator fan operates.
16	Intake Air Pressure Sensor #2	Atmospheric Pressure (Absolute) Pa = 100 ~ 900 mmHg	If the intake air pressure sensor #2 system fails (the signal is out of the usable range, wiring short or open), the ECU sets Pa at 760 mmHg (the standard atmospheric pressure).
21	Crankshaft Sensor	Crankshaft sensor must send 22 signals to the ECU at the 1 cranking.	If the crankshaft sensor generates less than 22 or more signals, the engine stops by itself.
24 and 25	Speed Sensor	Speed sensor must send 23 signals to the ECU at the one rotation of the drive shaft. The gear position is decided by the signal of the speed sensor.	If the speed sensor system fails (no signal, wiring short or open), the speedometer shows 0.
31	Vehicle-down Sensor	Output Voltage 0.10 ~ 4.84 V	If the vehicle-down sensor system has failures (the output voltage is out of the usable range, wiring short or open), the ECU shuts off the fuel pump relay, the fuel injectors and the ignition system.
32	Subthrottle Sensor	Output Voltage 0.15 ~ 4.85 V	If the subthrottle sensor system fails (the output voltage is out of the usable range, wiring short or open), the ECU drive the subthrottle valve to the full closed position, and it stops the current to the subthrottle valve actuator.
33	Oxygen Sensor (Equipped Models)	The oxygen sensor is active and sensor must send signals (output voltage) continuously to the ECU.	If the oxygen sensor is not activated, the ECU stops the feedback mode of the oxygen sensor.

Self-Diagnosis

Service Codes	Parts	Output Signal Usable Range or Criteria	Backups by ECU
34	Exhaust Butterfly Valve Actuator Sensor	Output Voltage 0.1 ~ 4.8 V	If the exhaust butterfly valve sensor system fails (the output voltage is out of the usable range, wiring short or open), the ECU locks the exhaust butterfly valve at full open position near, and it stops the current to the exhaust butterfly valve actuator.
35	Immobilizer Amplifier (Equipped Models)	—	If the immobilizer system fails (no signal, wiring short or open), the vehicle is no start and run.
36	Ignition Key (Equipped Models)	The ignition key must use register key.	If the blank key or broken key is used, the vehicle is no start and run.
39	ECU	The ECU send the data (for service code and key registration) to the meter unit.	—
51	Stick Coil #1*	The stick coil primary winding must send signals (output voltage) continuously to the ECU.	If the stick coil #1 primary winding has failures (no signal, wiring short or open), the ECU shuts off the injector #1 to stop fuel to the cylinder #1, though the engine keeps running.
52	Stick Coil #2*	The stick coil primary winding must send signals (output voltage) continuously to the ECU.	If the stick coil #2 primary winding has failures (no signal, wiring short or open), the ECU shuts off the injector #2 to stop fuel to the cylinder #2, though the engine keeps running.
53	Stick Coil #3*	The stick coil primary winding must send signals (output voltage) continuously to the ECU.	If the stick coil #3 primary winding has failures (no signal, wiring short or open), the ECU shuts off the injector #3 to stop fuel to the cylinder #3, though the engine keeps running.
54	Stick Coil #4*	The stick coil primary winding must send signals (output voltage) continuously to the ECU.	If the stick coil #4 primary winding has failures (no signal, wiring short or open), the ECU shuts off the injector #4 to stop fuel to the cylinder #4, though the engine keeps running.
56	Radiator Fan Relay	When the relay OFF condition, the fan relay is open.	—
62	Subthrottle Valve Actuator	The actuator operates open and close of the subthrottle valve by the pulse signal from the ECU.	If the subthrottle valve actuator fails (the signal is out to the usable range, wiring short or open), the ECU stops the current to the actuator.
63	Exhaust Butterfly Valve Actuator	The actuator operates open and close of the exhaust butterfly valve by the pulse signal from the ECU.	If the exhaust butterfly valve actuator fails (the signal is out to the usable range, wiring short or open), the ECU stops the current to the actuator.
64	Air Switching Valve	The air switching valve controls the flow of the secondary air by opening and shutting the solenoid valve.	—

3-44 FUEL SYSTEM (DFI)

Self-Diagnosis

Service Codes	Parts	Output Signal Usable Range or Criteria	Backups by ECU
67	Oxygen Sensor Heater (Equipped Models)	The oxygen sensor heater raise temperature of the sensor for its earlier activation.	If the oxygen sensor heater fails (wiring short or open), the ECU stops the current to the heater, and it stops the feedback mode of the oxygen sensor.
94	Oxygen Sensor (Equipped Models)	The oxygen sensor must send signals (output voltage) continuously to the ECU	If the oxygen sensor output voltage is incorrect, the ECU stops the feedback mode of the oxygen sensor.

Note:

(1) D-J Method: The DFI control method from medium to heavy engine load. When the engine load is light like at idling or low speed, the ECU determines the injection quantity by calculating from the throttle vacuum (intake air pressure sensor output voltage) and engine speed (crankshaft sensor output voltage). This method is called D-J method.

(2) α -N Method: As the engine speed increases, and the engine load turns middle to heavy, the ECU determines the injection quantity by calculating from the throttle opening (main throttle sensor output voltage) and the engine speed. This method is called α -N method.

*: This depends on the number of stopped cylinders.

Main Throttle Sensor (Service Code 11)

The main throttle sensor is a rotating variable resistor that change output voltage according to throttle operating. The ECU senses this voltage change and determines fuel injection quantity, and ignition timing according to engine rpm, and throttle opening.

Input Terminal [A]

Output Terminal [B]

Ground Terminal [C]

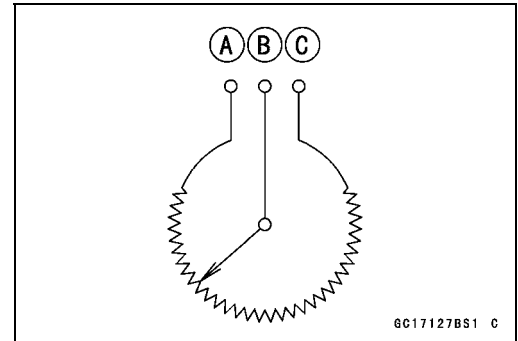

Main Throttle Sensor Removal/Adjustment

NOTICE

Do not remove or adjust the main throttle sensor [A] since it has been adjusted and set with precision at the factory.

Never drop the throttle body assy especially on a hard surface. Such a shock to the main throttle sensor can damage it.



Main Throttle Sensor Input Voltage Inspection

NOTE

○Be sure the battery is fully charged.

- Turn the ignition switch OFF.
- Remove the right lower fairing (see Lower Fairing Removal in the Frame chapter).
- Disconnect the main throttle sensor connector and connect the harness adapter [A] between these connectors.

Special Tool - Throttle Sensor Setting Adapter: 57001-1538

- Connect a digital meter to the harness adapter leads.

Main Throttle Sensor Input Voltage

Connections to Adapter:

Digital Meter (+) → W (sensor BL) lead

Digital Meter (-) → BK (sensor BR/BK) lead

- Measure the input voltage with the engine stopped and with the connector joined.
- Turn the ignition switch ON.

Input Voltage

Standard: DC 4.75 ~ 5.25 V

- Turn the ignition switch OFF.
- ★ If the reading is within the standard, check the output voltage (see Main Throttle Sensor Output Voltage Inspection).



3-46 FUEL SYSTEM (DFI)

Main Throttle Sensor (Service Code 11)

★ If the reading is out of the standard, remove the ECU and check the wiring for continuity between main harness connectors.

○ Disconnect the ECU and sensor connectors.

Wiring Inspection

ECU Connector [A] ↔

Main Throttle Sensor Connector [B]

BL lead (ECU terminal 5) [C]

BR/BK lead (ECU terminal 33) [D]

★ If the wiring is good, check the ECU for its ground and power supply (see ECU Power Supply Inspection).

★ If the ground and power supply are good, replace the ECU (see ECU Removal/Installation).

Main Throttle Sensor Output Voltage Inspection

● Measure the output voltage at the main throttle sensor in the same way as input voltage inspection, note the following.

○ Disconnect the main throttle sensor connector and connect the harness adapter [A] between these connectors.

Special Tool - Throttle Sensor Setting Adapter: 57001-1538

Main Throttle Sensor Output Voltage

Connections to Adapter:

Digital Meter (+) → R (sensor BL/W) lead

Digital Meter (-) → BK (sensor BR/BK) lead

● Start the engine and warm it up thoroughly.

● Check idle speed to ensure the throttle opening is correct.

Idle Speed

Standard: 1 100 ±50 r/min (rpm)

★ If the idle speed is out of the specified range, adjust it (see Idle Speed Inspection in the Periodic Maintenance chapter).

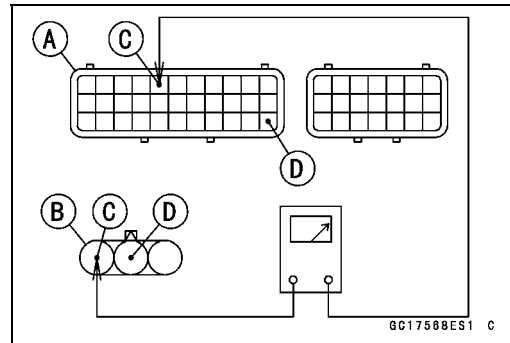

Main Throttle Sensor (Service Code 11)

- Turn the ignition switch OFF.
- Measure the output voltage with the engine stopped and with the connector joined.
- Turn the ignition switch ON.

Output Voltage

Standard: DC 1.02 ~ 1.06 V at idle throttle opening
 DC 4.22 ~ 4.42 V at full throttle opening (for reference)

NOTE

- Open the throttle, confirm the output voltage will be raise.
- The standard voltage refers to the value when the voltage reading at the Input Voltage Inspection shows 5 V exactly.
- When the input voltage reading shows other than 5 V, derive a voltage range as follows.

Example:

In the case of a input voltage of 4.75 V.

$$1.02 \times 4.75 \div 5.00 = 0.969 \text{ V}$$

$$1.06 \times 4.75 \div 5.00 = 1.007 \text{ V}$$

Thus, the valid range is 0.969 ~ 1.007 V

- Turn the ignition switch OFF.
- ★ If the reading is out of the standard, check the main throttle sensor resistance (see Main Throttle Sensor Resistance Inspection).
- ★ If the reading is within the standard, remove the ECU and check the wiring for continuity between main harness side connectors.
- Disconnect the ECU and sensor connectors.

Wiring Inspection

ECU Connector [A] ↔

Main Throttle Sensor Connector [B]

BL/W lead (ECU terminal 26) [C]

BR/BK lead (ECU terminal 33) [D]

- ★ If the wiring is good, check the ECU for its ground and power supply (see ECU Power Supply Inspection).
- ★ If the ground and power supply are good, replace the ECU (see ECU Removal/Installation).

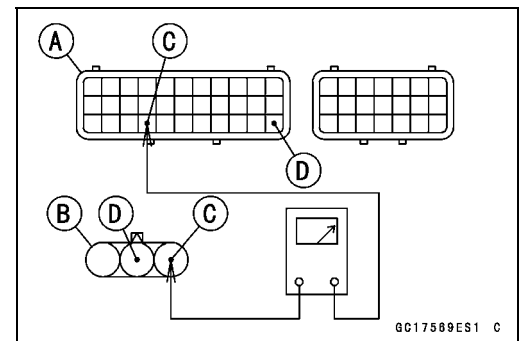

3-48 FUEL SYSTEM (DFI)

Main Throttle Sensor (Service Code 11)

Main Throttle Sensor Resistance Inspection

- Turn the ignition switch OFF.
- Disconnect the main throttle sensor connector.
- Disconnect the main throttle sensor connector and connect the harness adapter [A] to the sensor connector only.

Special Tool - Throttle Sensor Setting Adapter: 57001-1538

Main Throttle Sensor Resistance

Connections to Adapter:

Digital Meter (+) → W (sensor BL) lead

Digital Meter (-) → BK (sensor BR/BK) lead

Standard: 4 ~ 6 kΩ

- ★ If the reading is out of the standard, replace the throttle body assy.
- ★ If the reading is within the standard, but the problem still exists, replace the ECU (see ECU Removal/Installation).

Main Throttle Sensor Circuit

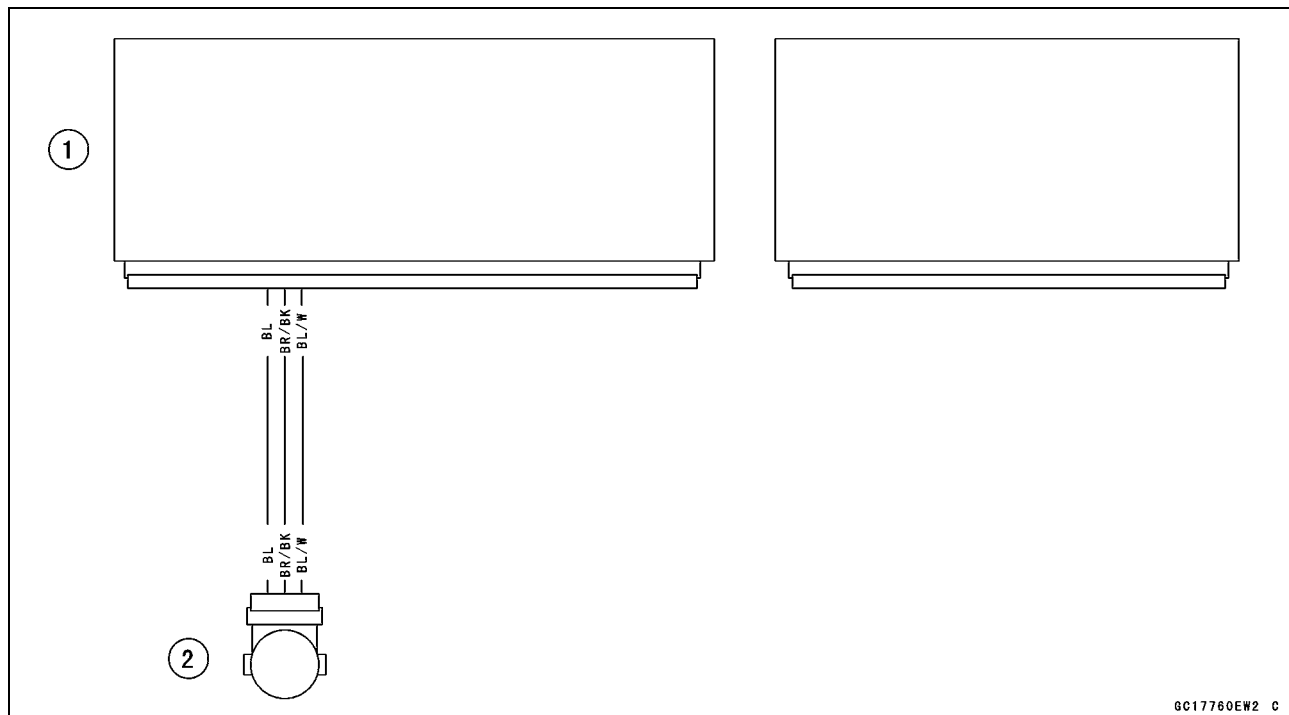

1. ECU

2. Main Throttle Sensor

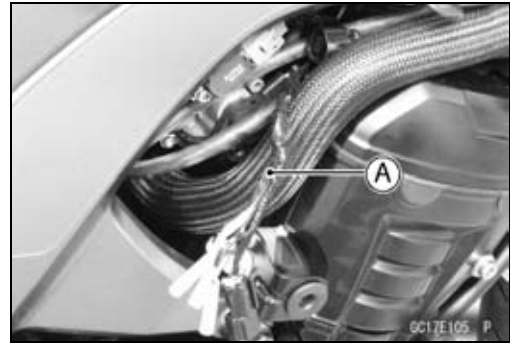

Intake Air Pressure Sensor #1 (Service Code 12)

Intake Air Pressure Sensor #1 Removal

NOTICE

Never drop the intake air pressure sensor #1 especially on a hard surface. Such a shock to the sensor can damage it.

- Remove:
 - Air Cleaner Housing (see Air Cleaner Housing Removal)
 - Intake Air Pressure Sensor #1 Connector [A]

- Remove the intake air pressure sensor #1 [A] from the rubber damper [B] in the bracket and separate the vacuum hose [C].

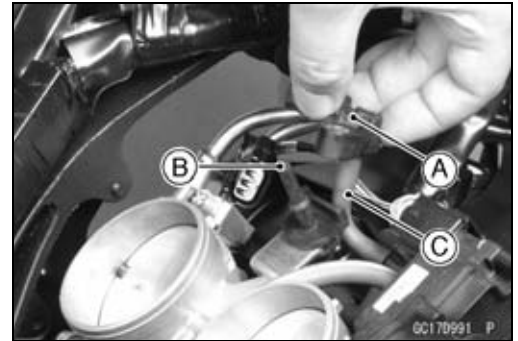

Intake Air Pressure Sensor #1 Installation

NOTE

○ The intake air pressure sensor #1 is the same part as the intake air pressure sensor #2.

- Installation is the reverse of removal.
- Position the intake air pressure sensor #1 [A] between the projections [B] on the rubber damper.

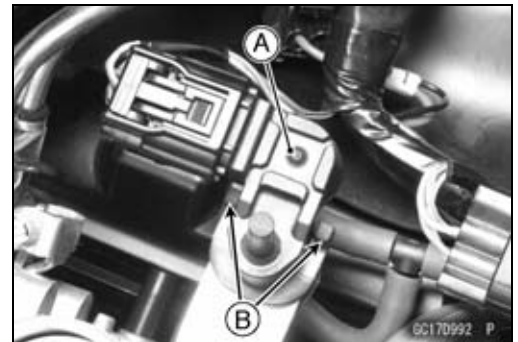

3-50 FUEL SYSTEM (DFI)

Intake Air Pressure Sensor #1 (Service Code 12)

Intake Air Pressure Sensor #1 Input Voltage Inspection

NOTE

○Be sure the battery is fully charged.

- Turn the ignition switch OFF.
- Remove the air cleaner housing (see Air Cleaner Housing Removal).
- Disconnect the intake air pressure sensor #1 connector and connect the harness adapter [A] between these connectors.

[B] Main Harness

[C] Intake Air Pressure Sensor #1

Special Tool - Measuring Adapter: 57001-1700

- Connect a digital meter [D] to the harness adapter leads.

Intake Air Pressure Sensor #1 Input Voltage Connections to Adapter:

Digital Meter (+) → R (sensor BL) lead

Digital Meter (-) → BK (sensor BR/BK) lead

- Measure the intake voltage with the engine stopped and with the connector joined.
- Turn the ignition switch ON.

Input Voltage

Standard: DC 4.75 ~ 5.25 V

- Turn the ignition switch OFF.
- ★ If the reading is within the standard, check the output voltage (see Intake Air Pressure Sensor #1 Output Voltage Inspection).
- ★ If the reading is out of the standard, remove the ECU and check the wiring for continuity between main harness connectors.

Special Tool - Hand Tester: 57001-1394

- Disconnect the ECU and sensor connectors.

Wiring Continuity Inspection

ECU Connector [A] ←→

Intake Air Pressure Sensor #1 Connector [B]

BL lead (ECU terminal 5) [C]

BR/BK lead (ECU terminal 33) [D]

- ★ If the wiring is good, check the ECU for its ground and power supply (see ECU Power Supply Inspection).
- ★ If the ground and power supply are good, replace the ECU (see ECU Removal/Installation).

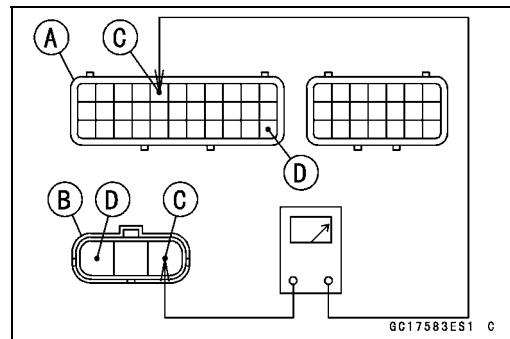
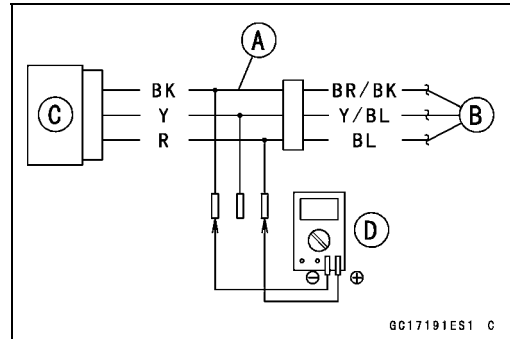

Intake Air Pressure Sensor #1 (Service Code 12)

Intake Air Pressure Sensor #1 Output Voltage Inspection

- Measure the output voltage at the intake air pressure sensor #1 in the same way as input voltage inspection, note the following.
- Disconnect the intake air pressure sensor #1 connector and connect the harness adapter [A] between these connectors.
 - [B] Main Harness
 - [C] Intake Air Pressure Sensor #1
 - [D] Digital Meter

Special Tool - Measuring Adapter: 57001-1700

Intake Air Pressure Sensor #1 Output Voltage Connections to Adapter:

- Digital Meter (+) → Y (sensor Y/BL) lead
- Digital Meter (-) → BK (sensor BR/BK) lead

- Measure the output voltage with the engine stopped and with the connector joined.
- Turn the ignition switch ON.

Output Voltage

Usable Range: DC 3.80 ~ 4.20 V at standard atmospheric pressure (101.32 kPa, 76 cmHg)

NOTE

- The output voltage changes according to local atmospheric pressure.
- Turn the ignition switch OFF.
- ★ If the reading is out of the usable range, replace the sensor.
- ★ If the reading is within the usable range, remove the ECU and check the wiring for continuity between main harness connector.

Special Tool - Hand Tester: 57001-1394

- Disconnect the ECU and sensor connectors.

Wiring Continuity Inspection

- ECU Connector [A] ↔
- Intake Air Pressure Sensor #1 Connector [B]
 - Y/BL lead (ECU terminal 17) [C]
 - BR/BK lead (ECU terminal 33) [D]

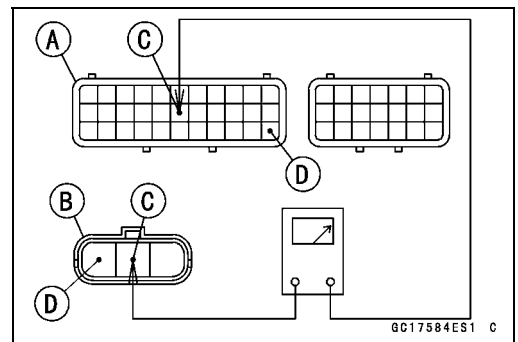
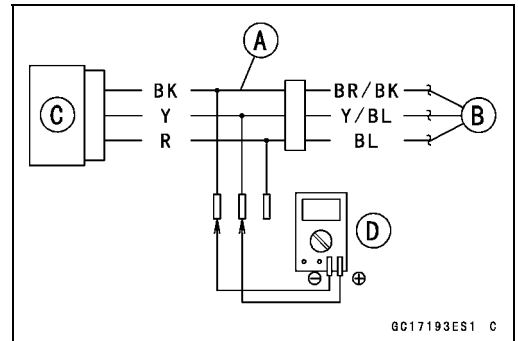

3-52 FUEL SYSTEM (DFI)

Intake Air Pressure Sensor #1 (Service Code 12)

- ★ If the wiring is good, check the sensor for various vacuum.
- Remove the intake air pressure sensor #1 [A] and disconnect the vacuum hose from the sensor.
- Connect an auxiliary hose [B] to the intake air pressure sensor #1.
- Temporarily install the intake air pressure sensor #1.
- Connect a digital meter [C], vacuum gauge [D], the fork oil level gauge [E] and the harness adapter to the intake air pressure sensor #1.

Special Tools - Fork Oil Level Gauge: 57001-1290
Vacuum Gauge: 57001-1369
Measuring Adapter: 57001-1700

Intake Air Pressure Sensor #1 Output Voltage Connections to Adapter:

- Digital Meter (+) → Y (sensor Y/BL) lead**
- Digital Meter (-) → BK (sensor BR/BK) lead**

- Turn the ignition switch ON.
- Measure the intake air pressure sensor #1 output voltage from various vacuum readings, while pulling the handle of the fork oil level gauge.
- Check the intake air pressure sensor #1 output voltage, using the following formula and chart.

Suppose:

- Pg: Vacuum Pressure (Gauge) of Throttle Body
- PI: Local Atmospheric Pressure (Absolute) measured by a barometer
- Pv: Vacuum Pressure (Absolute) of Throttle Body
- Vv: Sensor Output Voltage (V)

then

$$Pv = PI - Pg$$

For example, suppose the following data is obtained:

- Pg = 8 cmHg (Vacuum Gauge Reading)
- PI = 70 cmHg (Barometer Reading)
- Vv = 3.2 V (Digital Meter Reading)

then

$$Pv = 70 - 8 = 62 \text{ cmHg (Absolute)}$$

Plot this Pv (62 cmHg) at a point [1] on the chart and draw a vertical line through the point. Then, you can get the usable range [2] of the sensor output voltage.

$$\text{Usable range} = 3.08 \sim 3.48 \text{ V}$$

Plot Vv (3.2 V) on the vertical line. → Point [3].

Results: In the chart, Vv is within the usable range and the sensor is normal.

- ★ If the reading is out of the usable range, replace the sensor.
- ★ If the reading is within the usable range, check the ECU for its ground and power supply (see ECU Power Supply Inspection).
- ★ If the ground and power supply are good, replace the ECU (see ECU Removal/Installation).

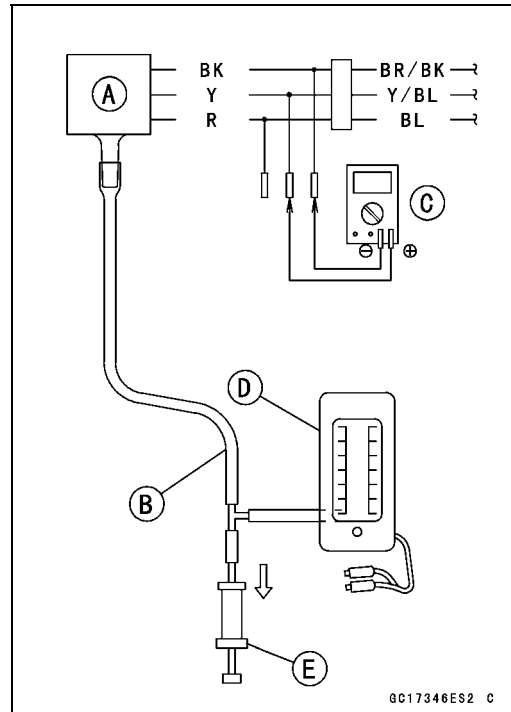

Intake Air Pressure Sensor #1 (Service Code 12)

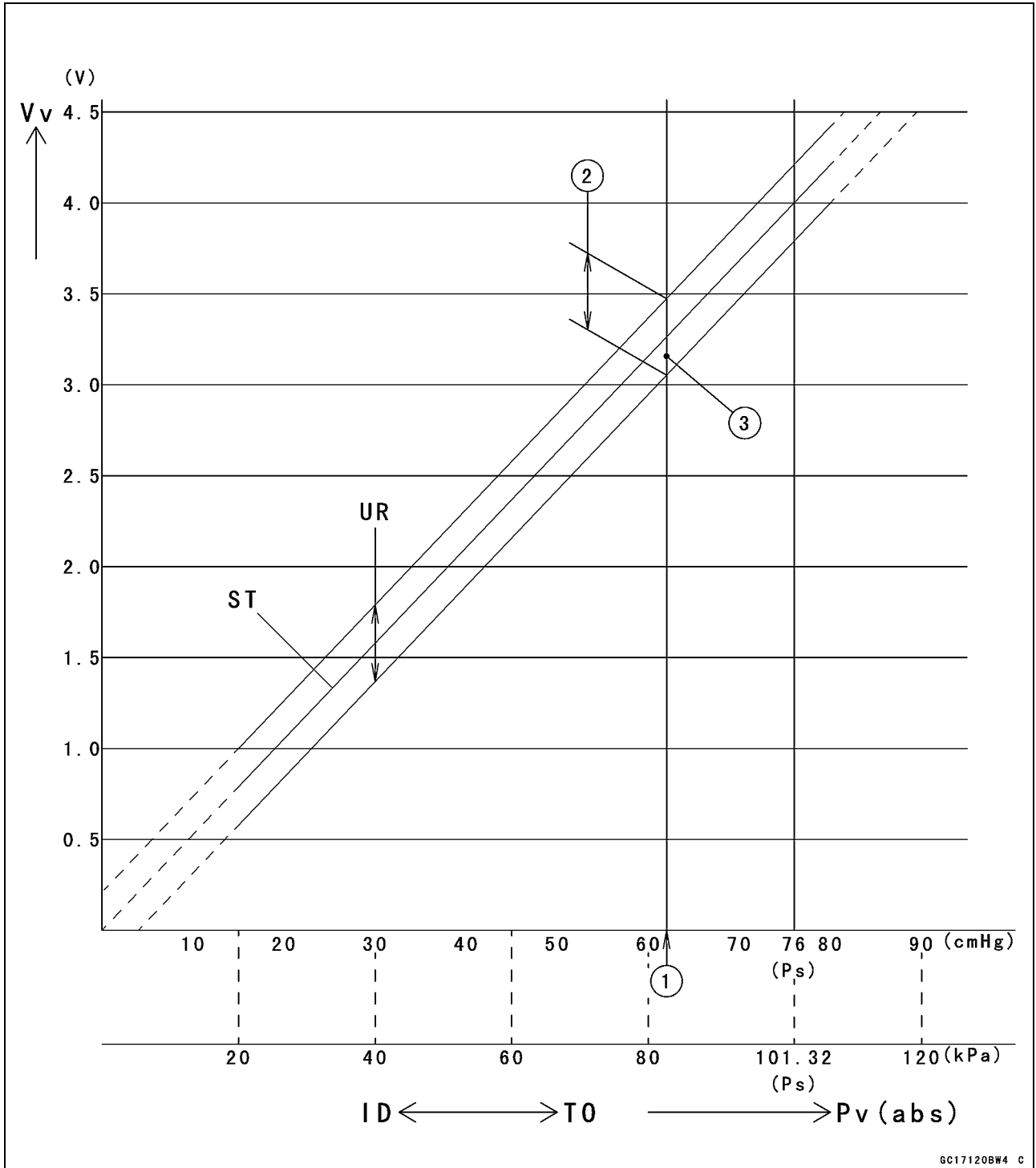

ID: Idling

Ps: Standard Atmospheric Pressure (Absolute)

Pv: Throttle Vacuum Pressure (Absolute)

ST: Standard of Sensor Output Voltage (V)

TO: Throttle Full Open

UR: Usable Range of Sensor Output Voltage (V)

Vv: Intake Air Pressure Sensor #1 Output Voltage (V) (Digital Meter Reading)

3-54 FUEL SYSTEM (DFI)

Intake Air Pressure Sensor #1 (Service Code 12)

Intake Air Pressure Sensor #1 Circuit

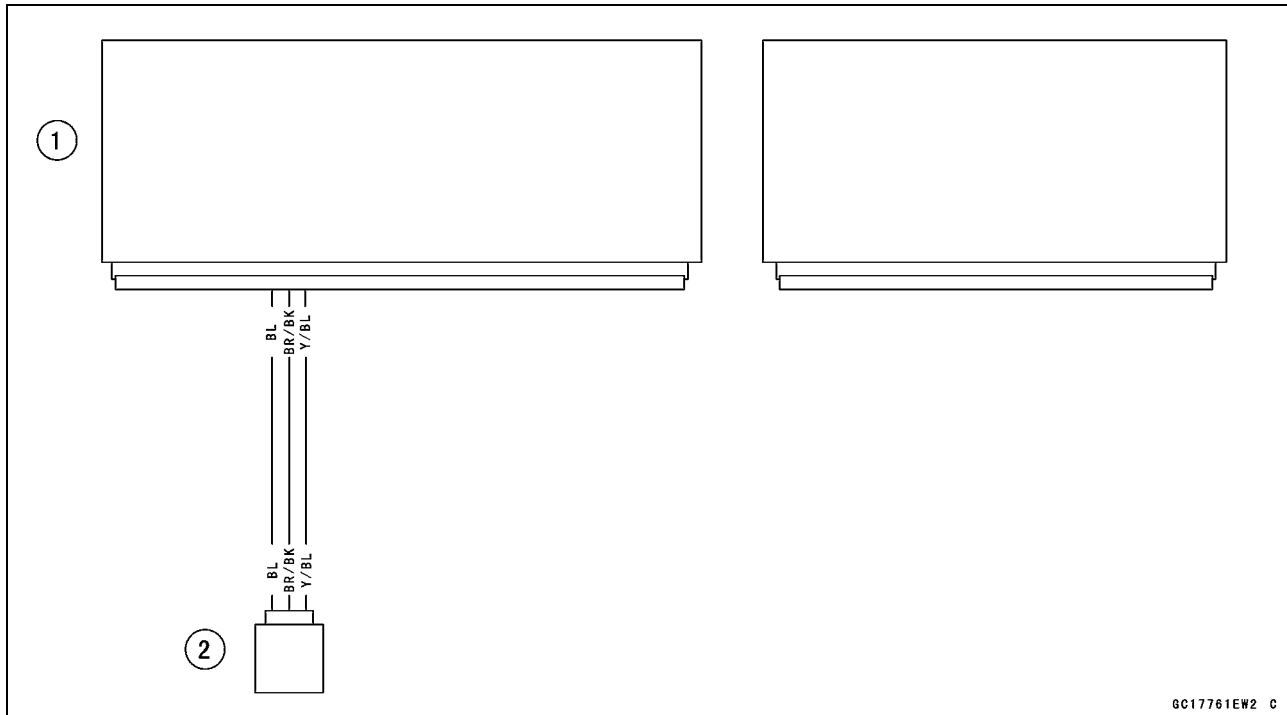

1. ECU

2. Intake Air Pressure Sensor #1

Intake Air Temperature Sensor (Service Code 13)

Intake Air Temperature Sensor Removal/Installation

NOTICE

Never drop the intake air temperature sensor especially on a hard surface. Such a shock to the sensor can damage it.

- Remove the fuel tank (see Fuel Tank Removal).
- Disconnect the connector [A] from the intake air temperature sensor [B].
- Remove:
 - Screw [C]
 - Intake Air Temperature Sensor
- Be sure to install the O-ring [A].
- Install the intake air temperature sensor.
- Tighten:
 - Torque - Intake Air Temperature Sensor Mounting Screw:**
1.2 N·m (0.12 kgf·m, 11 in·lb)

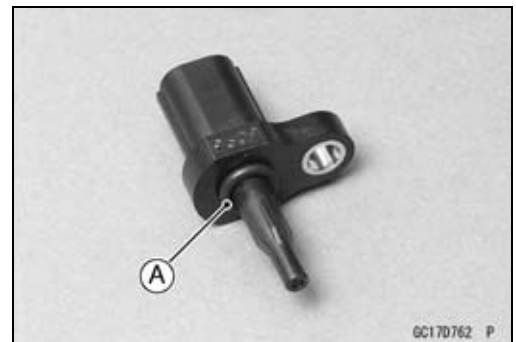
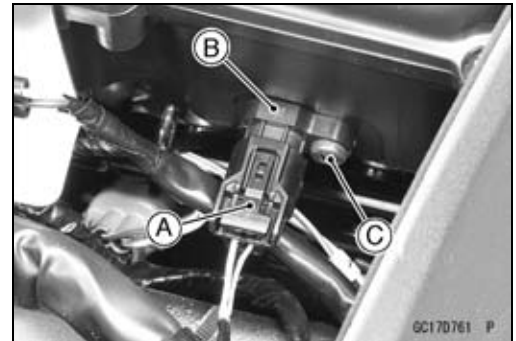

Intake Air Temperature Sensor Output Voltage Inspection

NOTE

○ Be sure the battery is fully charged.

- Turn the ignition switch OFF.
- Remove the fuel tank (see Fuel Tank Removal).
- Disconnect the intake air temperature sensor connector and connect the harness adapter [A] between these connectors as shown.
 - Main Harness [B]
 - Intake Air Temperature Sensor [C]

Special Tool - Measuring Adapter: 57001-1700

- Connect a digital meter [D] to the harness adapter leads.

Intake Air Temperature Sensor Output Voltage Connections to Adapter:

- Digital Meter (+) → R (sensor Y) lead
- Digital Meter (-) → BK (sensor BR/BK) lead

- Measure the output voltage with the engine stopped and the connector joined.
- Turn the ignition switch ON.

Output Voltage

Standard: About DC 2.25 ~ 2.50 V at 20°C (68°F)

NOTE

○ The output voltage changes according to the intake air temperature.

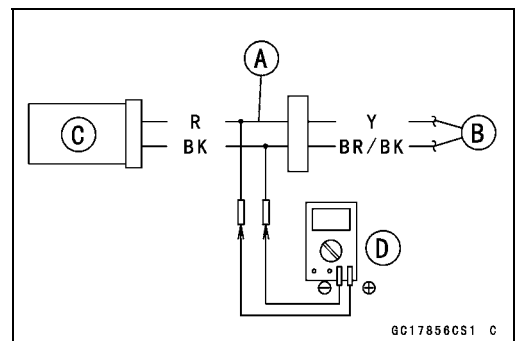
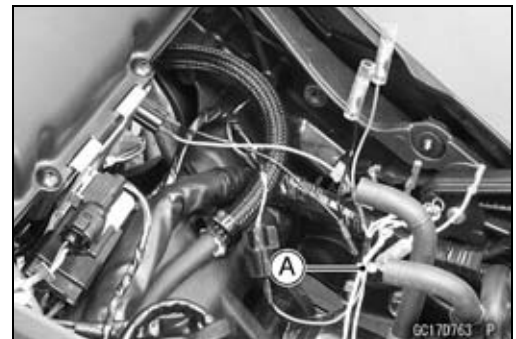

3-56 FUEL SYSTEM (DFI)

Intake Air Temperature Sensor (Service Code 13)

- Turn the ignition switch OFF.
- ★ If the reading is within the standard, check the ECU for its ground, and power supply (see ECU Power Supply Inspection).
- ★ If the ground and power supply are good, replace the ECU (see ECU Removal/Installation).
- ★ If the reading is out of the standard, remove the ECU and check the wiring for continuity between main harness connectors.
- Disconnect the ECU and sensor connectors.

Wiring Inspection

ECU Connector [A] ←→

Intake Air Temperature Sensor Connector [B]

Y lead (ECU terminal 15) [C]

BR/BK lead (ECU terminal 33) [D]

- ★ If the wiring is good, check the intake air temperature sensor resistance (see Intake Air Temperature Sensor Resistance Inspection).

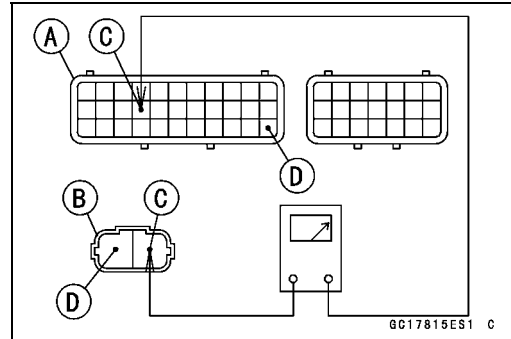

Intake Air Temperature Sensor Resistance Inspection

- Remove the intake air temperature sensor (see Intake Air Temperature Sensor Removal/Installation).
- Suspend the sensor [A] in a container of machine oil so that the heat-sensitive portion is submerged.
- Suspend a thermometer [B] with the heat-sensitive portion [C] located in almost the same depth with the sensor.

NOTE

○ The sensor and thermometer must not touch the container side or bottom.

- Place the container over a source of heat and gradually raise the temperature of the oil while stirring the oil gently for even temperature.
- Using a digital meter, measure the internal resistance of the sensor across the terminals at the temperatures shown in the following.

Intake Air Temperature Sensor Resistance

Standard: 5.4 ~ 6.6 k Ω at 0°C (32°F)

0.29 ~ 0.39 k Ω at 80°C (176°F)

- ★ If the reading is out of the standard, replace the sensor.
- ★ If the reading is within the standard, but the problem still exists, replace the ECU (see ECU Removal/Installation).

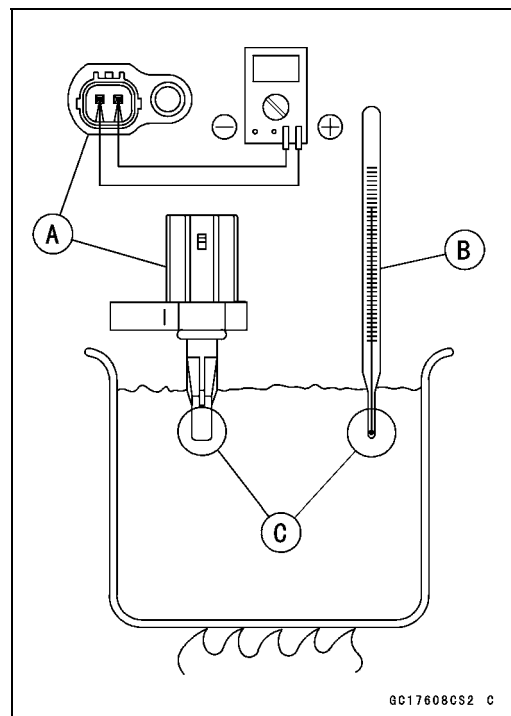

Intake Air Temperature Sensor (Service Code 13)

Intake Air Temperature Sensor Circuit

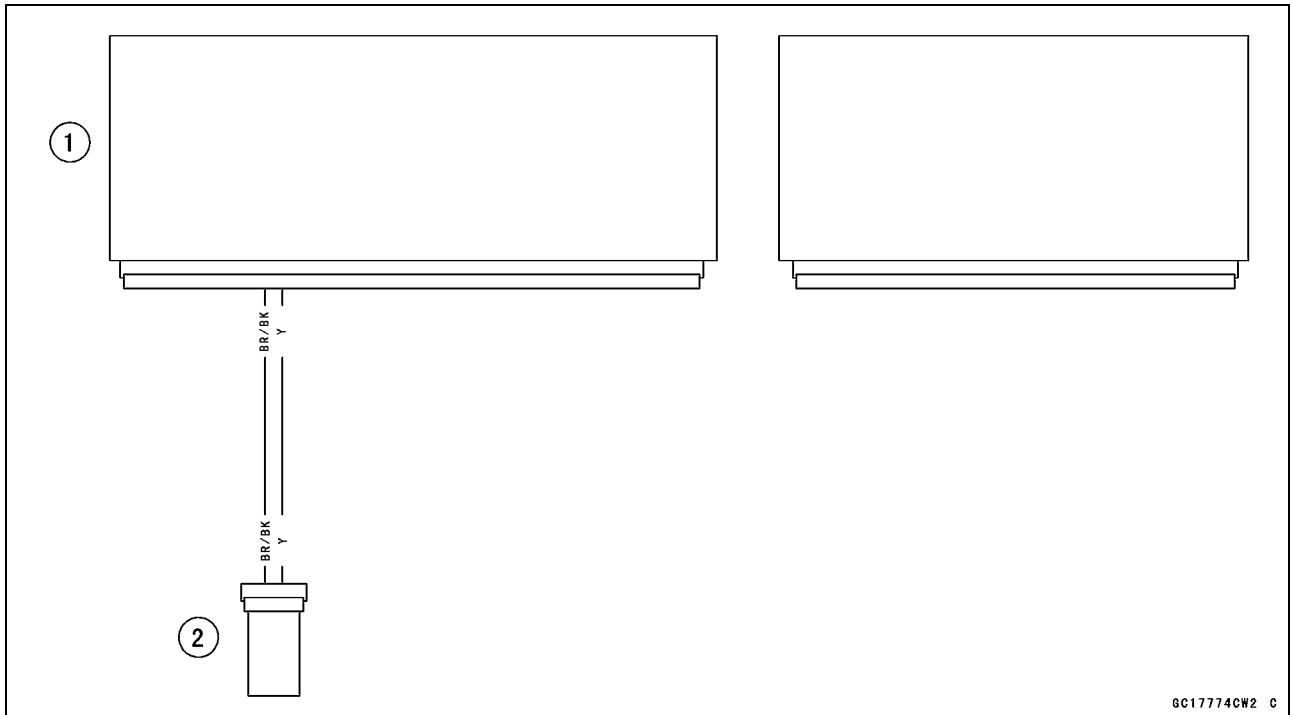

GC1774CW2 C

- 1. ECU
- 2. Intake Air Temperature Sensor

3-58 FUEL SYSTEM (DFI)

Water Temperature Sensor (Service Code 14)

Water Temperature Sensor Removal/Installation

NOTICE

Never drop the water temperature sensor especially on a hard surface. Such a shock to the sensor can damage it.

- Drain the coolant (see Coolant Change in the Periodic Maintenance chapter).
- Remove:
 - Left Lower Fairing (see Lower Fairing Removal in the Frame chapter)
 - Connector [A]
 - Water Temperature Sensor [B]
- Replace the gasket with a new one, and tighten the water temperature sensor.
Torque - Water Temperature Sensor: 30 N·m (3.0 kgf·m, 22 ft·lb)
- Fill the engine with coolant and bleed the air from the cooling system (see Coolant Change in the Periodic Maintenance chapter).

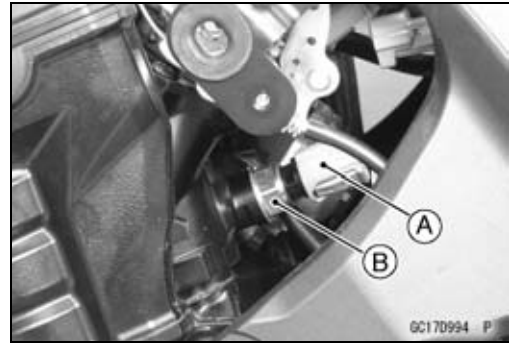

Water Temperature Sensor (Service Code 14)

Water Temperature Sensor Output Voltage Inspection

NOTE

○Be sure the battery is fully charged.

- Turn the ignition switch OFF.
- Remove the left lower fairing (see Lower Fairing Removal in the Frame chapter)
- Disconnect the water temperature sensor connector and connect the harness adapter [A] between these connectors as shown.

Sub Harness [B]
Water Temperature Sensor [C]

Special Tool - Measuring Adapter: 57001-1700

- Connect a digital meter [D] to the harness adapter leads.

Water Temperature Sensor Output Voltage Connections to Adapter:

Digital Meter (+) → R (sensor W/R) lead

Digital Meter (-) → BK (sensor W/BL) lead

- Measure the output voltage with the engine stopped and with the connector joined.
- Turn the ignition switch ON.

Output Voltage

Standard: About DC 2.80 ~ 2.97 V at 20°C (68°F)

NOTE

○The output voltage changes according to the coolant temperature in the engine.

- Turn the ignition switch OFF.
- ★ If the reading is within the standard, check the ECU for its ground and power supply (see ECU Power Supply Inspection).
- ★ If the ground and power supply are good, replace the ECU (see ECU Removal/Installation).
- ★ If the reading is out of the standard, remove the ECU and check the wiring for continuity between main and sub harness connectors.
- Disconnect the ECU and sensor connectors.

Wiring Inspection

ECU Connector [A] ↔

Sub Harness Connector [B]

O lead (ECU terminal 29) [C]

BR/BK lead (ECU terminal 33) [D]

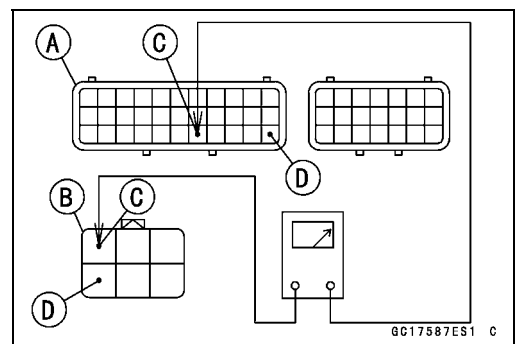
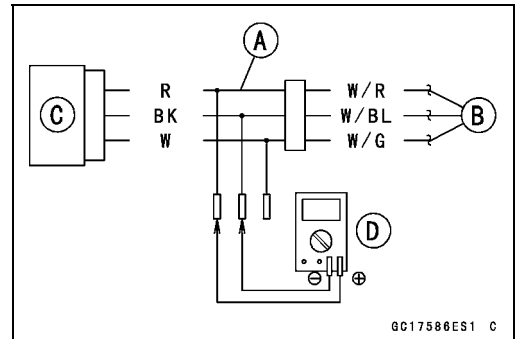
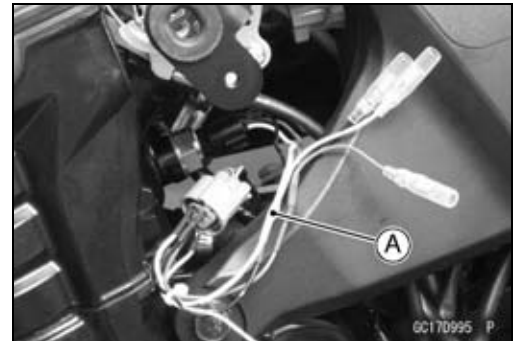

3-60 FUEL SYSTEM (DFI)

Water Temperature Sensor (Service Code 14)

Sub Harness Connector [A] ↔

Sub Harness Connector [B]

W/R lead [C]

W/BL lead [D]

★ If the wiring is good, check the water temperature sensor resistance (see Water Temperature Sensor Resistance Inspection).

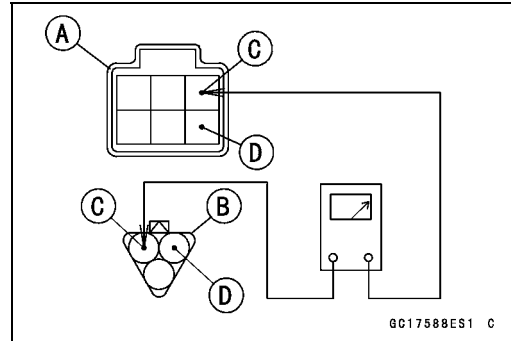

Water Temperature Sensor Resistance Inspection

- Refer to the Water Temperature Sensor Inspection in the Electrical System chapter.
- ★ If the reading is within the standard, but the problem still exists, replace the ECU (see ECU Removal/Installation).

Water Temperature Sensor Circuit

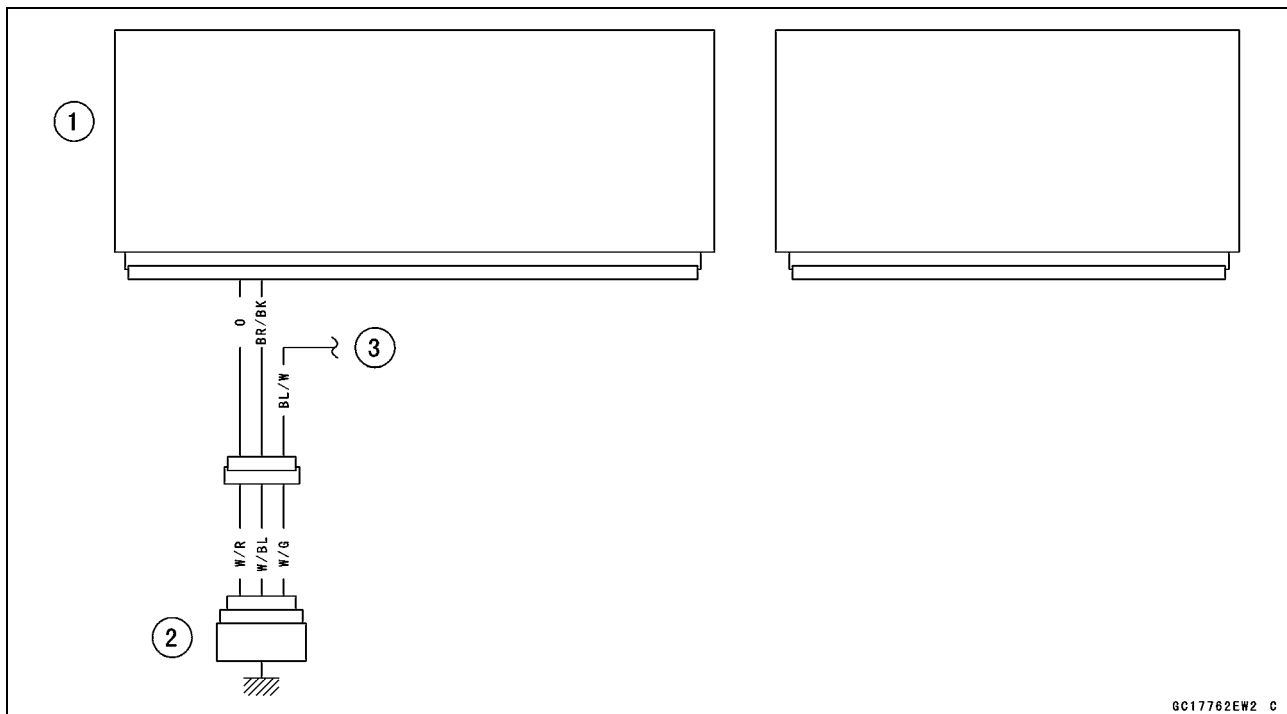

1. ECU
2. Water Temperature Sensor
3. To Meter Unit

Intake Air Pressure Sensor #2 (Service Code 16)

Intake Air Pressure Sensor #2 Removal

NOTICE

Never drop the intake air pressure sensor #2 especially on a hard surface. Such a shock to the sensor can damage it.

- Remove the air cleaner housing (see Air Cleaner Housing Removal).
- Disconnect the sensor connector [A].

- Remove the intake air pressure sensor #2 [A] from the rubber damper [B] in the bracket and separate the vacuum hose [C].

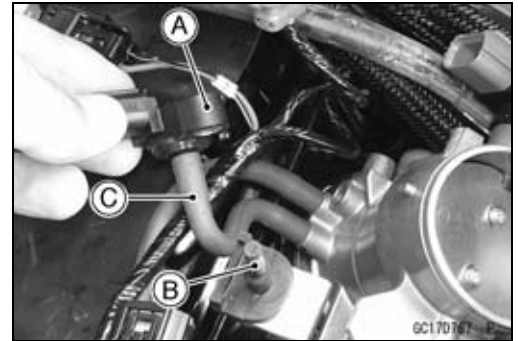

Intake Air Pressure Sensor #2 Installation

NOTE

○ The intake air pressure sensor #2 is the same part as the intake air pressure sensor #1.

- Installation is the reverse of removal.
- Position the intake air pressure sensor #2 [A] between the projection [B] on the rubber damper.

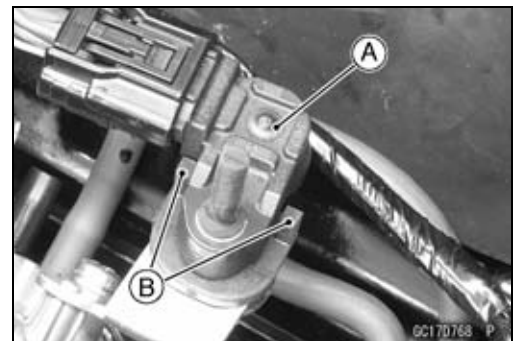

3-62 FUEL SYSTEM (DFI)

Intake Air Pressure Sensor #2 (Service Code 16)

Intake Air Pressure Sensor #2 Input Voltage Inspection

NOTE

○Be sure the battery is fully charged.

- Turn the ignition switch OFF.
- Remove the air cleaner housing (see Air Cleaner Housing Removal).
- Disconnect the intake air pressure sensor #2 connector and connect the harness adapter [A] between these connectors.

[B] Main Harness

[C] Intake Air Pressure Sensor #2

Special Tool - Measuring Adapter: 57001-1700

- Connect a digital meter [D] to the harness adapter leads.

Intake Air Pressure Sensor #2 Input Voltage Connections to Adapter:

Digital Meter (+) → R (sensor BL) lead

Digital Meter (-) → BK (sensor BR/BK) lead

- Measure the input voltage with the engine stopped and with the connector joined.
- Turn the ignition switch ON.

Input Voltage

Standard: DC 4.75 ~ 5.25 V

- Turn the ignition switch OFF.
- ★ If the reading is within the standard, check the output voltage (see Intake Air Pressure Sensor #2 Output Voltage Inspection).
- ★ If the reading is out of the standard, remove the ECU and check the wiring for continuity between main harness connectors.

Special Tool - Hand Tester: 57001-1394

- Disconnect the ECU and sensor connectors.

Wiring Continuity Inspection

ECU Connector [A] ↔

Intake Air Pressure Sensor #2 Connector [B]

BL lead (ECU terminal 5) [C]

BR/BK lead (ECU terminal 33) [D]

- ★ If the wiring is good, check the ECU for its ground and power supply (see ECU Power Supply Inspection).
- ★ If the ground and power supply are good, replace the ECU (see ECU Removal/Installation).

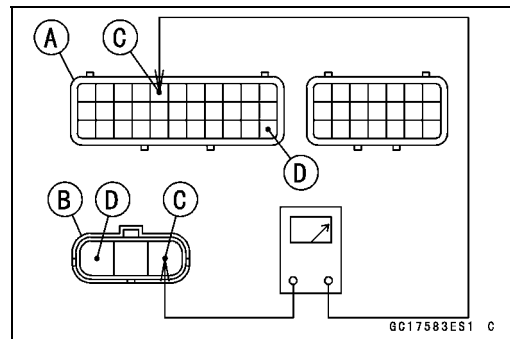
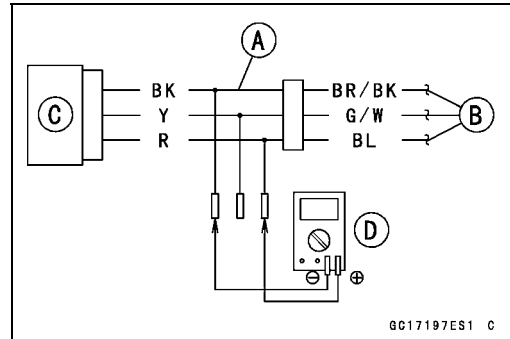

Intake Air Pressure Sensor #2 (Service Code 16)

Intake Air Pressure Sensor #2 Output Voltage Inspection

- Measure the output voltage at the intake air pressure sensor #2 in the same way as input voltage inspection, note the following.
- Disconnect the intake air pressure sensor #2 connector and connect the harness adapter [A] between these connectors.
 - [B] Main Harness
 - [C] Intake Air Pressure Sensor #2
 - [D] Digital Meter

Special Tool - Measuring Adapter: 57001-1700

Intake Air Pressure Sensor #2 Output Voltage Connections to Adapter:

- Digital Meter (+) → Y (sensor G/W) lead
- Digital Meter (-) → BK (sensor BR/BK) lead

- Measure the output voltage with the engine stopped and with the connector joined.
- Turn the ignition switch ON.

Output Voltage

Usable Range: DC 3.80 ~ 4.20 V at standard atmospheric pressure (101.32 kPa, 76 cmHg absolute)

NOTE

- The output voltage changes according to the local atmospheric pressure.
- Turn the ignition switch OFF.
- ★ If the reading is out of the usable range, replace the sensor.
- ★ If the reading is within the usable range, remove the ECU and check the wiring for continuity between main harness connector.

Special Tool - Hand Tester: 57001-1394

- Disconnect the ECU and sensor connectors.

Wiring Continuity Inspection

- ECU Connector [A] ↔
- Intake Air Pressure Sensor #2 Connector [B]
- G/W lead (ECU terminal 16) [C]
- BR/BK lead (ECU terminal 33) [D]

- ★ If the wiring is good, check the sensor for various vacuum (see Intake Air Pressure Sensor #1 Output Voltage Inspection).

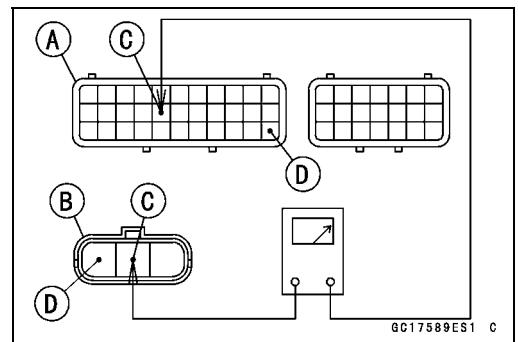
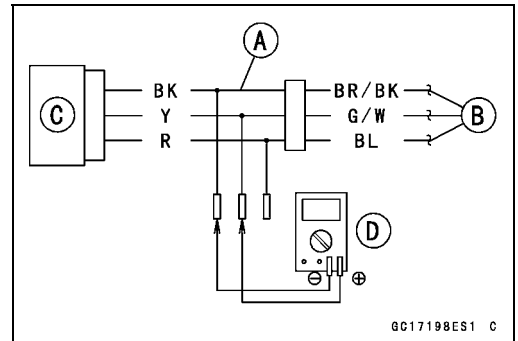

3-64 FUEL SYSTEM (DFI)

Intake Air Pressure Sensor #2 (Service Code 16)

Intake Air Pressure Sensor #2 Circuit

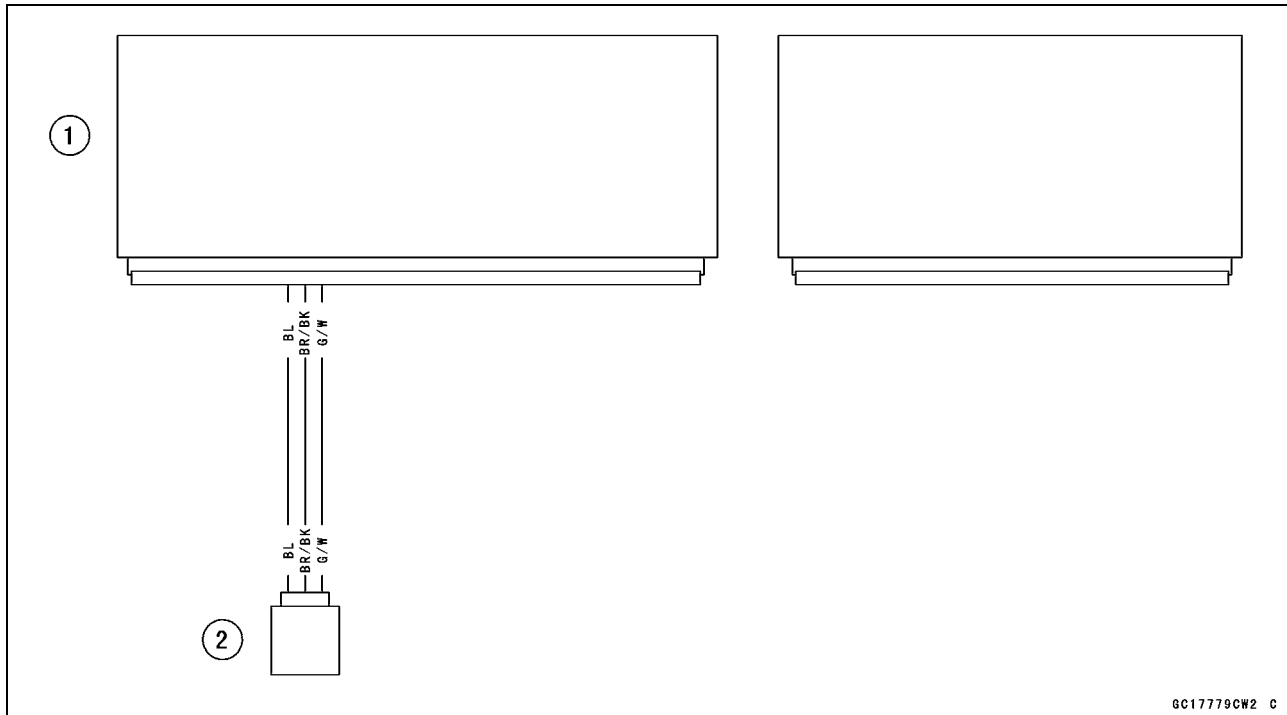

1. ECU

2. Intake Air Pressure Sensor #2

Crankshaft Sensor (Service Code 21)

The crankshaft sensor has no power source, and when the engine stops, the crankshaft sensor generates no signals.

Crankshaft Sensor Removal/Installation

- Refer to the Crankshaft Sensor Removal/Installation in the Electrical System chapter.

Crankshaft Sensor Resistance Inspection

- Refer to the Crankshaft Sensor Inspection in the Electrical System chapter.
- ★ If the reading is within the standard, check the peak voltage (see Crankshaft Sensor Peak Voltage Inspection).

Crankshaft Sensor Peak Voltage Inspection

- Refer to the Crankshaft Sensor Peak Voltage Inspection in the Electrical System chapter.
- ★ If the reading is within the standard, remove the ECU and check the wiring for continuity between main harness connectors.
- Disconnect the ECU and sensor connectors.

Wiring Inspection

ECU Connector [A] ↔

Crankshaft Sensor Connector [B]

Y/BK lead (ECU terminal 20) [C]

BK lead (ECU terminal 21) [D]

- ★ If the wiring is good, check the ECU for its ground and power supply (see ECU Power Supply Inspection).
- ★ If the ground and power supply are good, replace the ECU (see ECU Removal/Installation).

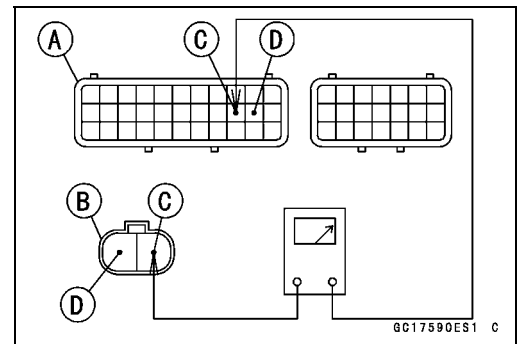

Crankshaft Sensor Circuit

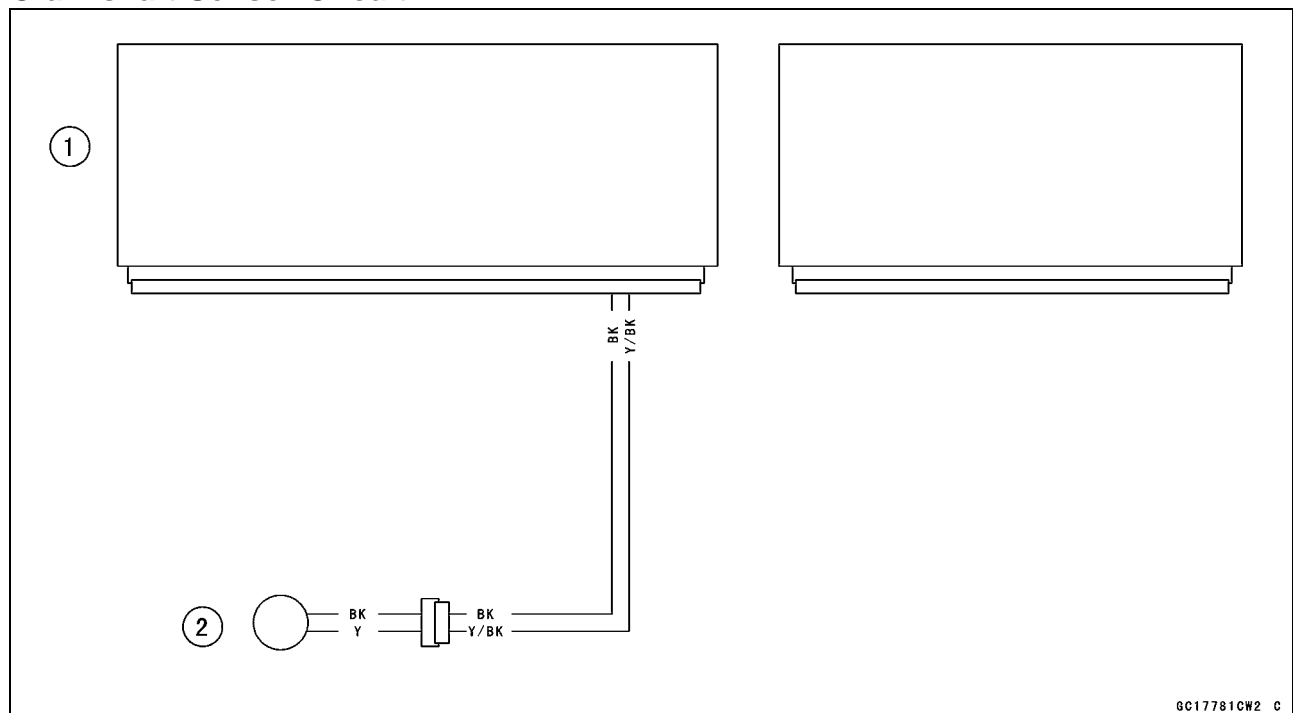

1. ECU
2. Crankshaft Sensor

3-66 FUEL SYSTEM (DFI)

Speed Sensor (Service Code 24, 25)

Speed Sensor Removal/Installation

- Refer to the Speed Sensor Removal/Installation in the Electrical System chapter.

Speed Sensor Inspection

- Refer to the Speed Sensor Inspection in the Electrical System chapter.

Speed Sensor Input Voltage Inspection

NOTE

○ Be sure the battery is fully charged.

- Turn the ignition switch OFF.
- Remove the fuel tank (see Fuel Tank Removal).
- Disconnect the speed sensor connector and connect the harness adapter [A] between these connectors.

Special Tool - Throttle Sensor Setting Adapter #1: 57001-1400

- Connect a digital meter to the harness adapter leads.

Speed Sensor Input Voltage

Connections to Adapter:

Digital Meter (+) → BL (sensor P) lead

Digital Meter (-) → BK/BL (sensor BK) lead

- Measure the input voltage with the engine stopped and with the connector joined.
- Turn the ignition switch ON.

Input Voltage

Standard: About DC 9 ~ 11 V

- Turn the ignition switch OFF.
- ★ If the reading is within the standard, check the output voltage (see Speed Sensor Output Voltage Inspection).
- ★ If the reading is out of the standard, remove the ECU and check the wiring for continuity between main harness connectors.
- Disconnect the ECU and sensor connectors.

Wiring Inspection

ECU Connector [A] ←→

Speed Sensor Connector [B]

BL lead (ECU terminal 5) [C]

BR/BK lead (ECU terminal 33) [D]

- ★ If the wiring is good, check the ECU for its ground and power supply (see ECU Power Supply Inspection).
- ★ If the ground and power supply are good, replace the ECU (see ECU Removal/Installation).

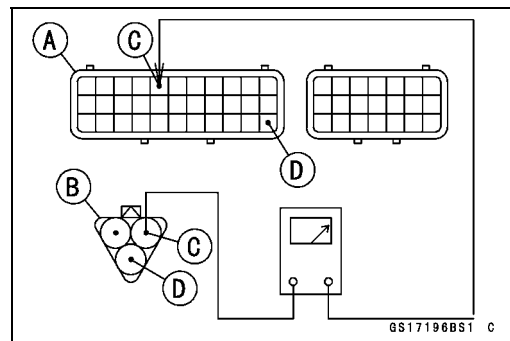

Speed Sensor (Service Code 24, 25)

Speed Sensor Output Voltage Inspection

- Using the stand, raise the rear wheel off the ground.
- Measure the output voltage at the speed sensor in the same way as input voltage inspection, note the following.
- Disconnect the speed sensor connector and connect the harness adapter [A] between these connectors.

Special Tool - Throttle Sensor Setting Adapter #1: 57001-1400

Speed Sensor Output Voltage Connections to Adapter:

Digital Meter (+) → Y/W (sensor Y) lead

Digital Meter (-) → BK/BL (sensor BK) lead

- Measure the output voltage with the engine stopped and with the connector joined.
- Turn the ignition switch ON.

Output Voltage

Standard: Less than DC 0.6 V or over than 4.8 V at ignition switch ON and 0 km/h

NOTE

○ Rotate the rear wheel by hand, confirm the output voltage will be raise or lower.

- Turn the ignition switch OFF.
- ★ If the reading is out of the standard, check the speed sensor (see Speed Sensor Inspection in the Electrical System chapter).
- ★ If the reading is within the standard, remove the ECU and check the wiring for continuity between main harness connectors.
- Disconnect the ECU and sensor connectors.

Wiring Inspection

ECU Connector [A] ↔

Speed Sensor Connector [B]

P lead (ECU terminal 22) [C]

BR/BK lead (ECU terminal 33) [D]

- ★ If the wiring is good, check the ECU for its ground and power supply (see ECU Power Supply Inspection).
- ★ If the ground and power supply are good, replace the ECU (see ECU Removal/Installation).

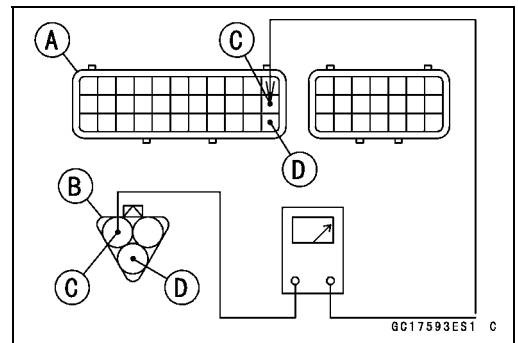

3-68 FUEL SYSTEM (DFI)

Speed Sensor (Service Code 24, 25)

Speed Sensor Circuit

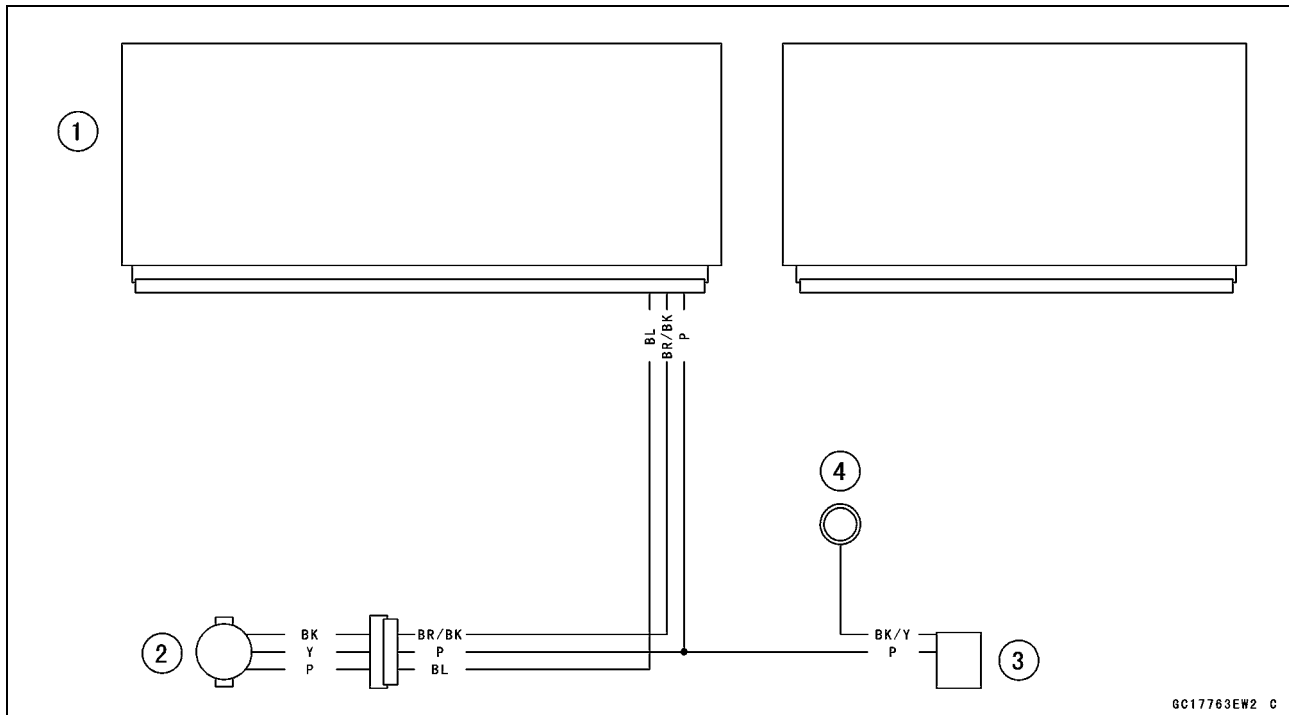

6C17763EW2 C

1. ECU
2. Speed Sensor
3. Meter Unit
4. Meter Ground

Vehicle-down Sensor (Service Code 31)

This sensor has a weight [A] with two magnets inside, and sends a signal to the ECU. But when the motorcycle banks 60 ~ 70° or more to either side (in fact falls down), the weight turns and the signal changes. The ECU senses this change, and stops the fuel pump relay, the fuel injectors and the ignition system.

Hall IC [B]

When the motorcycle is down, the ignition switch is left ON. If the starter button is pushed, the electric starter turns but the engine does not start. To start the engine again, raise the motorcycle, turn the ignition switch OFF, and then ON.

- Vehicle-down Sensor [A]
- Ground Terminal BR/BK [B]
- Output Terminal Y/G [C]
- Power Source Terminal BL [D]

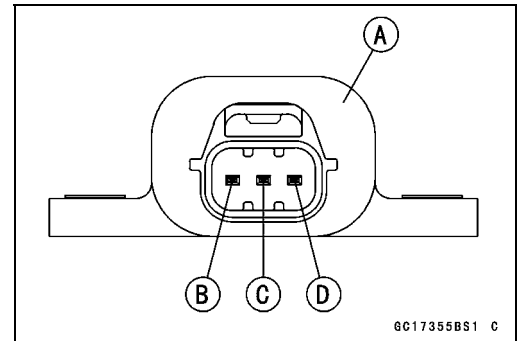
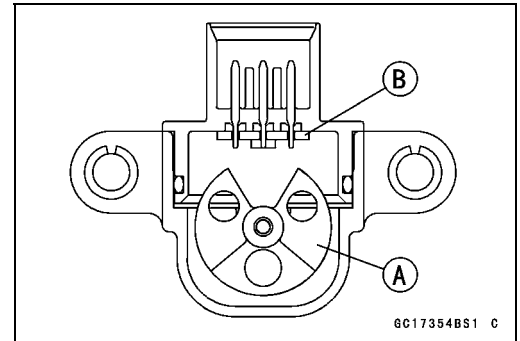

Vehicle-down Sensor Removal

NOTICE

Never drop the vehicle-down sensor especially on a hard surface. Such a shock to the sensor can damage it.

- Remove:
 - Front Seat (see Front Seat Removal in the Frame chapter)
 - Fuel Tank (See Fuel Tank Removal)
 - Bolts [A]
 - Fuel Tank Bracket [B]

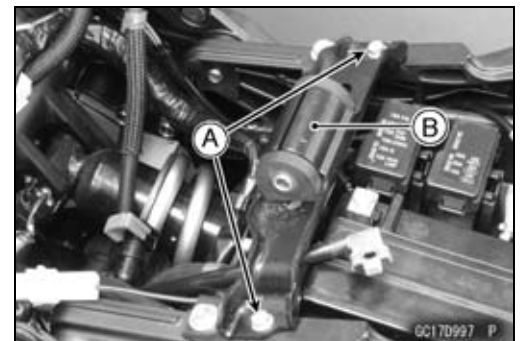

- Remove:
 - Connector [A]
 - Bolts [B] and Bracket [C]
 - Vehicle-down Sensor [D]

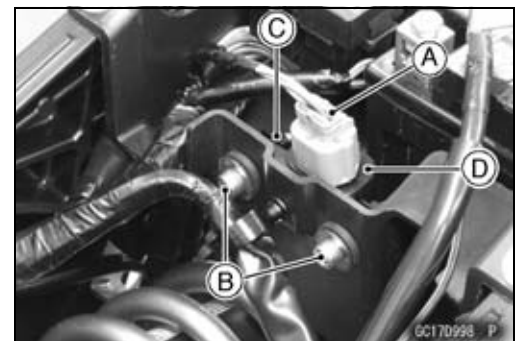

3-70 FUEL SYSTEM (DFI)

Vehicle-down Sensor (Service Code 31)

Vehicle-down Sensor Installation

- Be sure to install the rubber dampers [A] and collars [B] on the battery case.

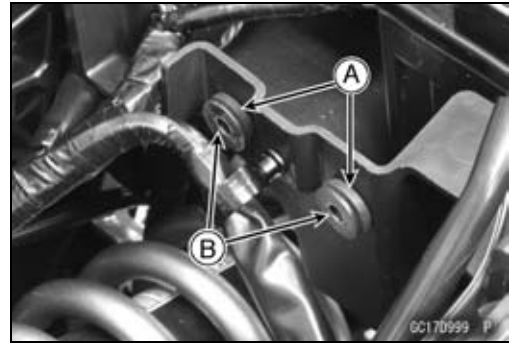

- The UP mark [A] of the sensor should face upward.

⚠ WARNING

Incorrect installation of the vehicle-down sensor could cause sudden loss of engine power. The rider could lose balance during certain riding situations for an accident resulting in injury or death. Ensure that the vehicle-down sensor is held in place by the battery case.

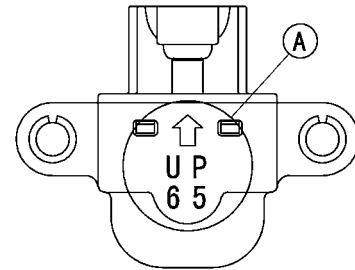

GC17358BS1 C

Vehicle-down Sensor Input Voltage Inspection

NOTE

○ Be sure the battery is fully charged.

- Turn the ignition switch OFF.
- Disconnect the vehicle-down sensor connector and connect the harness adapter [A] between these connectors as shown.

Main Harness [B]

Vehicle-down Sensor [C]

Special Tool - Measuring Adapter: 57001-1700

- Connect a digital meter [D] to the harness adapter leads.

Vehicle-down Sensor Input Voltage

Connections to Adapter:

Digital Meter (+) → R (sensor BL) lead

Digital Meter (-) → BK (sensor BR/BK) lead

- Measure the input voltage with the engine stopped and with the connector joined.
- Turn the ignition switch ON.

Input Voltage

Standard: DC 4.75 ~ 5.25 V

- Turn the ignition switch OFF.
- ★ If the reading is within the standard, check the output voltage (see Vehicle-down Sensor Output Voltage Inspection).

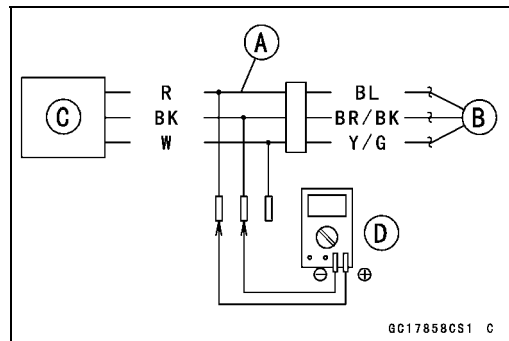
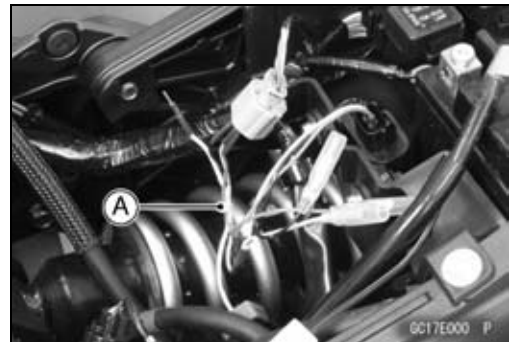

GC17858CS1 C

Vehicle-down Sensor (Service Code 31)

- ★ If the reading is out of the standard, remove the ECU and check the wiring for continuity between main harness connectors.
- Disconnect the ECU and sensor connections.

Wiring Inspection

ECU Connector [A] ←→

Vehicle-down Sensor Connector [B]

BL lead (ECU terminal 5) [C]

BR/BK lead (ECU terminal 33) [D]

- ★ If the wiring is good, check the ECU for its ground and power supply (see ECU Power Supply Inspection).
- ★ If the ground and power supply are good, replace the ECU (see ECU Removal/Installation).

Vehicle-down Sensor Output Voltage Inspection

- Remove the vehicle-down sensor (see Vehicle-down Sensor Removal).
- Connect the harness adapter [A] to the vehicle-down sensor connectors as shown.

Special Tool - Measuring Adapter: 57001-1700

Main Harness [B]

Vehicle-down Sensor [C]

- Connect a digital meter [D] to the harness adapter leads.

Vehicle-down Sensor Output Voltage

Connections to Adapter:

Digital Meter (+) → W (sensor Y/G) lead

Digital Meter (-) → BK (sensor BR/BK) lead

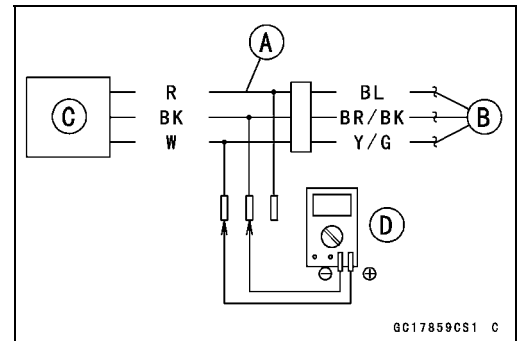
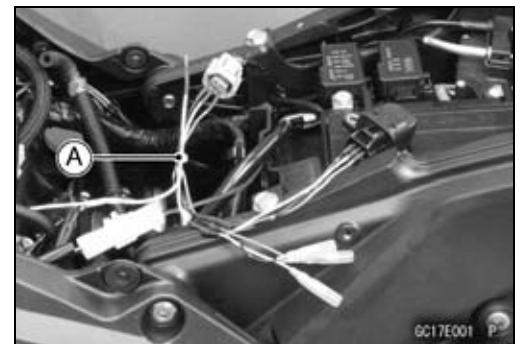
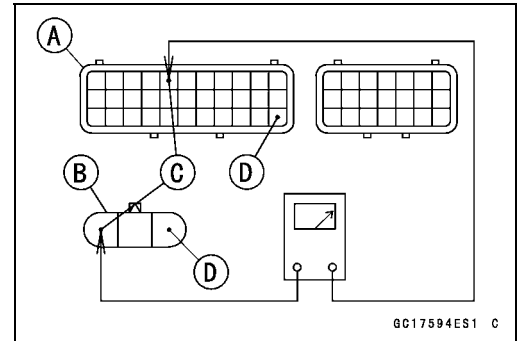

3-72 FUEL SYSTEM (DFI)

Vehicle-down Sensor (Service Code 31)

- Hold the sensor vertically.
- Measure the output voltage with the engine stopped and with the connector joined.
- Turn the ignition switch ON.
- Tilt the sensor 60 ~ 70° or more [A] right or left, then hold the sensor almost vertical with the arrow mark pointed up [B], and measure the output voltage.

Output Voltage

Standard: With sensor tilted 60 ~ 70° or more right or left: DC 0.65 ~ 1.35 V

With sensor arrow mark pointed up: DC 3.55 ~ 4.45 V

NOTE

○ If you need to test again, turn the ignition switch OFF, and then ON.

- Turn the ignition switch OFF.
- ★ If the reading is out of the standard, replace the sensor.

- ★ If the reading is within the standard, remove the ECU and check the wiring for continuity between main harness connectors.
- Disconnect the ECU and sensor connectors.

Wiring Inspection

ECU Connector [A] ←→

Vehicle-down Sensor Connector [B]

Y/G lead (ECU terminal 19) [C]

BR/BK lead (ECU terminal 33) [D]

- ★ If the wiring is good, check the ECU for its ground and power supply (see ECU Power Supply Inspection).
- ★ If the ground and power supply are good, replace the ECU (see ECU Removal/Installation).

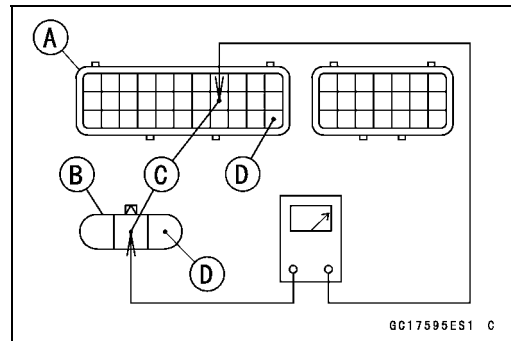
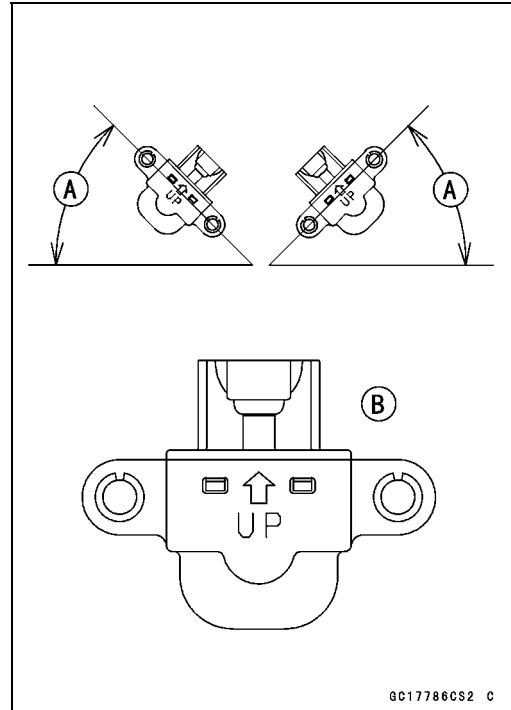

Vehicle-down Sensor (Service Code 31)

Vehicle-down Sensor Circuit

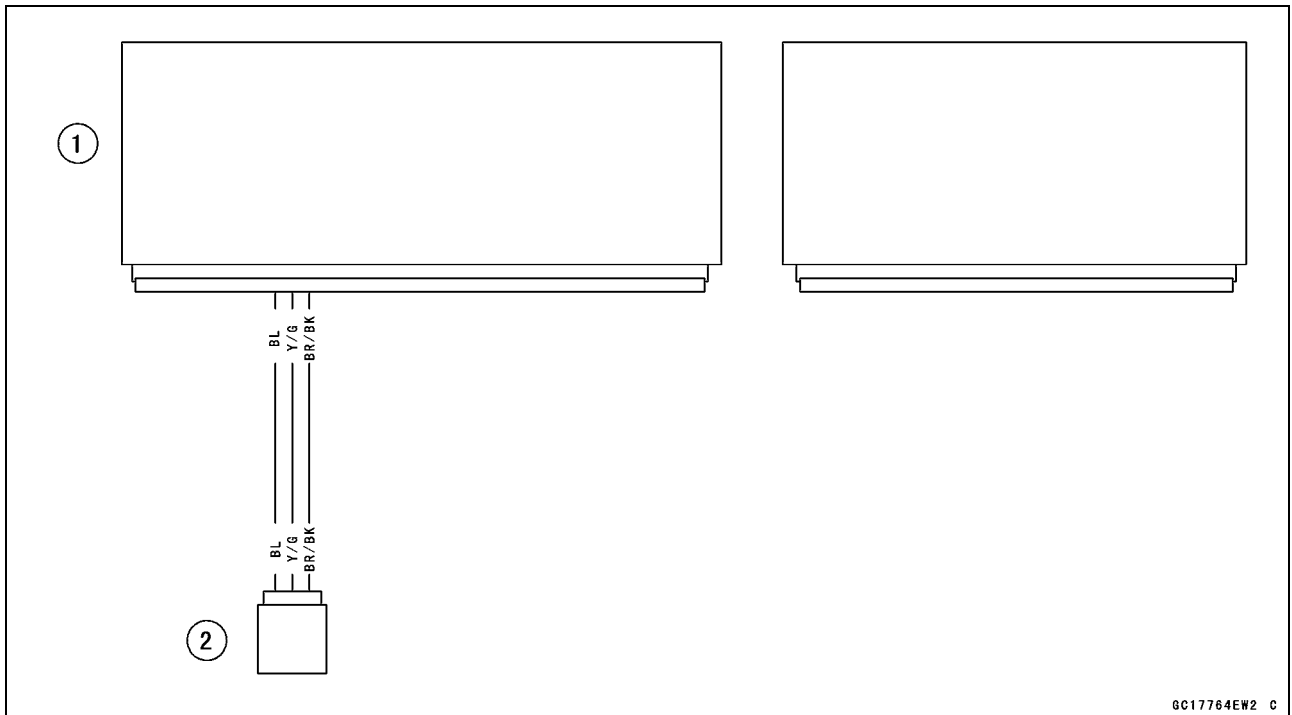

- 1. ECU
- 2. Vehicle-down Sensor

3-74 FUEL SYSTEM (DFI)

Subthrottle Sensor (Service Code 32)

The subthrottle sensor is a rotating variable resistor that change output voltage according to throttle operating. The ECU senses this voltage change and determines fuel injection quantity, and ignition timing according to engine rpm, and throttle opening.

Input Terminal [A]

Output Terminal [B]

Ground Terminal [C]

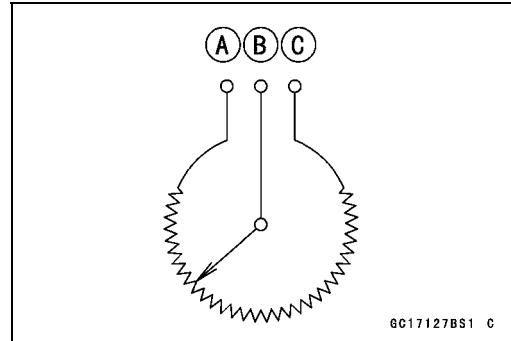

Subthrottle Sensor Removal/Adjustment

NOTICE

Do not remove or adjust the subthrottle sensor [A] since it has been adjusted and set with precision at the factory.

Never drop the throttle body assy especially on a hard surface. Such a shock to the subthrottle sensor can damage it.

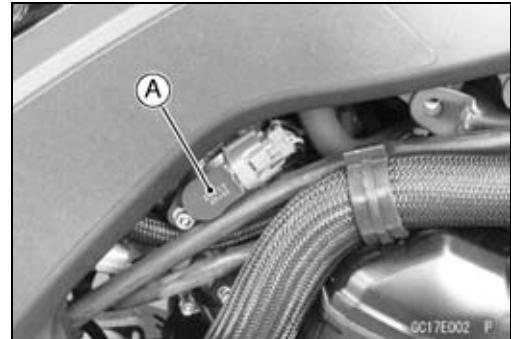

Subthrottle Sensor Input Voltage Inspection

NOTE

○Be sure the battery is fully charged.

- Turn the ignition switch OFF.
- Remove the right lower fairing (see Lower Fairing Removal in the Frame chapter).
- Disconnect the subthrottle sensor and connect the harness adapter [A] between these connectors.

Special Tool - Throttle Sensor Setting Adapter: 57001-1538

- Connect a digital meter to the harness adapter leads.

Subthrottle Sensor Input Voltage

Connections to Adapter:

Digital Meter (+) → W (sensor BL) lead

Digital Meter (-) → BK (sensor BR/BK) lead

- Measure the input voltage with the engine stopped and with the connector joined.
- Turn the ignition switch ON.

Input Voltage

Standard: DC 4.75 ~ 5.25 V

- Turn the ignition switch OFF.
- ★ If the reading is within the standard, check the output voltage (see Subthrottle Sensor Output Voltage Inspection).



Subthrottle Sensor (Service Code 32)

★ If the reading is out of the standard, remove the ECU and check the wiring for continuity between main harness connectors.

○ Disconnect the ECU and sensor connectors.

Wiring Inspection

ECU Connector [A] ←→

Subthrottle Sensor Connector [B]

BL lead (ECU terminal 5) [C]

BR/BK lead (ECU terminal 33) [D]

★ If the wiring is good, check the ECU for its ground and power supply (see ECU Power Supply Inspection).

★ If the ground and power supply are good, replace the ECU (see ECU Removal/Installation).

Subthrottle Sensor Output Voltage Inspection

● Measure the output voltage at the subthrottle sensor in the same way as input voltage inspection, note the following.

○ Disconnect the subthrottle sensor connector and connect the harness adapter [A] between these connectors.

Special Tool - Throttle Sensor Setting Adapter: 57001-1538

Subthrottle Sensor Output Voltage

Connections to Adapter:

Digital Meter (+) → R (sensor BR) lead

Digital Meter (-) → BK (sensor BR/BK) lead

● Remove the air cleaner housing (see Air Cleaner Housing Removal).

● Disconnect the subthrottle valve actuator harness connector [A].

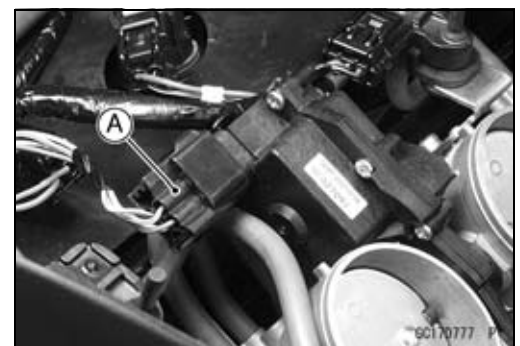
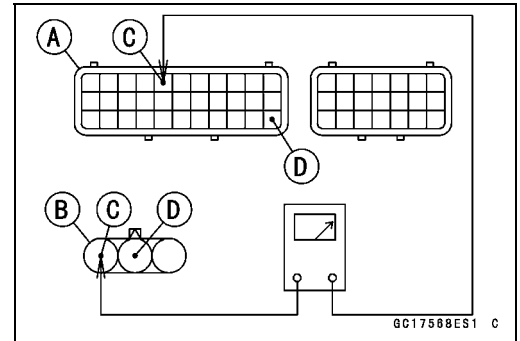

3-76 FUEL SYSTEM (DFI)

Subthrottle Sensor (Service Code 32)

- Measure the output voltage with the engine stopped with the connector joined.
- Remove the left lower side fairing (see Left Lower Side Fairing Removal in the Frame chapter).
- Turn the ignition switch ON.
- Measure the output voltage when the subthrottle valve is completely closed by turning the lever [A] fully clockwise [B].

Output Voltage

Standard: DC 1.08 ~ 1.12 V at subthrottle valve full close position

DC 4.2 ~ 4.4 V at subthrottle valve full open position (for reference)

NOTE

- Turn the lever counterclockwise, confirm the output voltage will be raise.
 - The standard voltage refers to the value when the voltage reading at the Input Voltage Inspection shows 5 V exactly.
 - When the input voltage reading shows other than 5 V, derive a voltage range as follows.
Example:
In the case of a input voltage of 4.75 V.
 $1.08 \times 4.75 \div 5.00 = 1.03 \text{ V}$
 $1.12 \times 4.75 \div 5.00 = 1.06 \text{ V}$
Thus, the valid range is 1.03 ~ 1.06 V
- Turn the ignition switch OFF.
 - ★ If the reading is out of the standard, check the subthrottle sensor resistance (see Subthrottle Sensor Resistance Inspection).
 - ★ If the reading is within the standard, remove the ECU and check the wiring for continuity between main harness connectors.
 - Disconnect the ECU and sensor connectors.

Wiring Inspection

ECU Connector [A] ←→

Subthrottle Sensor Connector [B]

BR lead (ECU terminal 27) [C]

BR/BK lead (ECU terminal 33) [D]

- ★ If the wiring is good, check the ECU for its ground and power supply (see ECU Power Supply Inspection).
- ★ If the ground and power supply are good, replace the ECU (see ECU Removal/Installation).

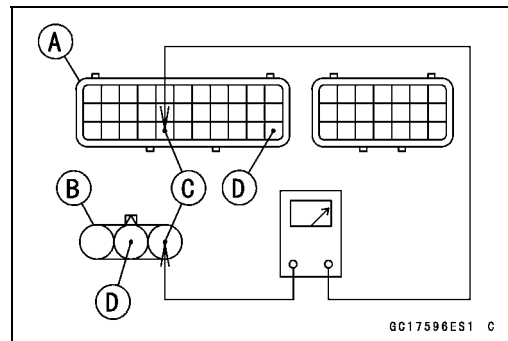
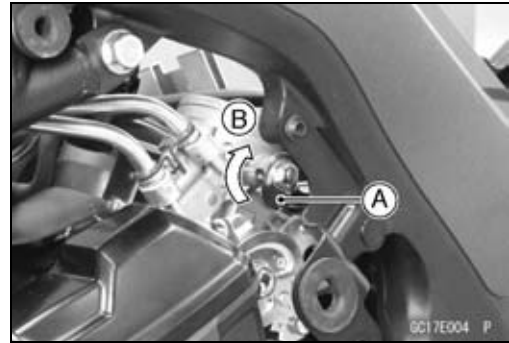

Subthrottle Sensor (Service Code 32)

Subthrottle Sensor Resistance Inspection

- Turn the ignition switch OFF.
- Disconnect the subthrottle sensor connector.
- Disconnect the subthrottle sensor connector and connect the harness adapter [A] to the sensor connector only.

Special Tool - Throttle Sensor Setting Adapter: 57001-1538

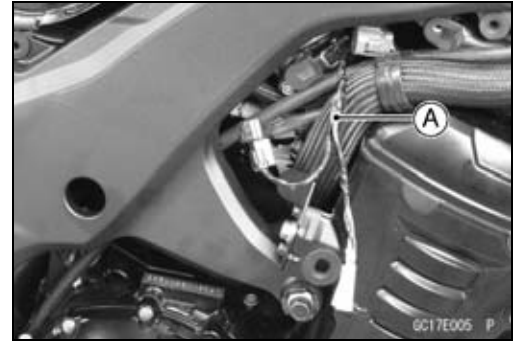

Subthrottle Sensor Output Resistance Connections to Adapter:

Digital Meter (+) → W (sensor BL) lead

Digital Meter (-) → BK (sensor BR/BK) lead

Standard: 4 ~ 6 kΩ

- ★ If the reading is out of the standard, replace the throttle body assy.
- ★ If the reading is within the standard, but the problem still exists, replace the ECU (see ECU Removal/Installation).

Subthrottle Sensor Circuit

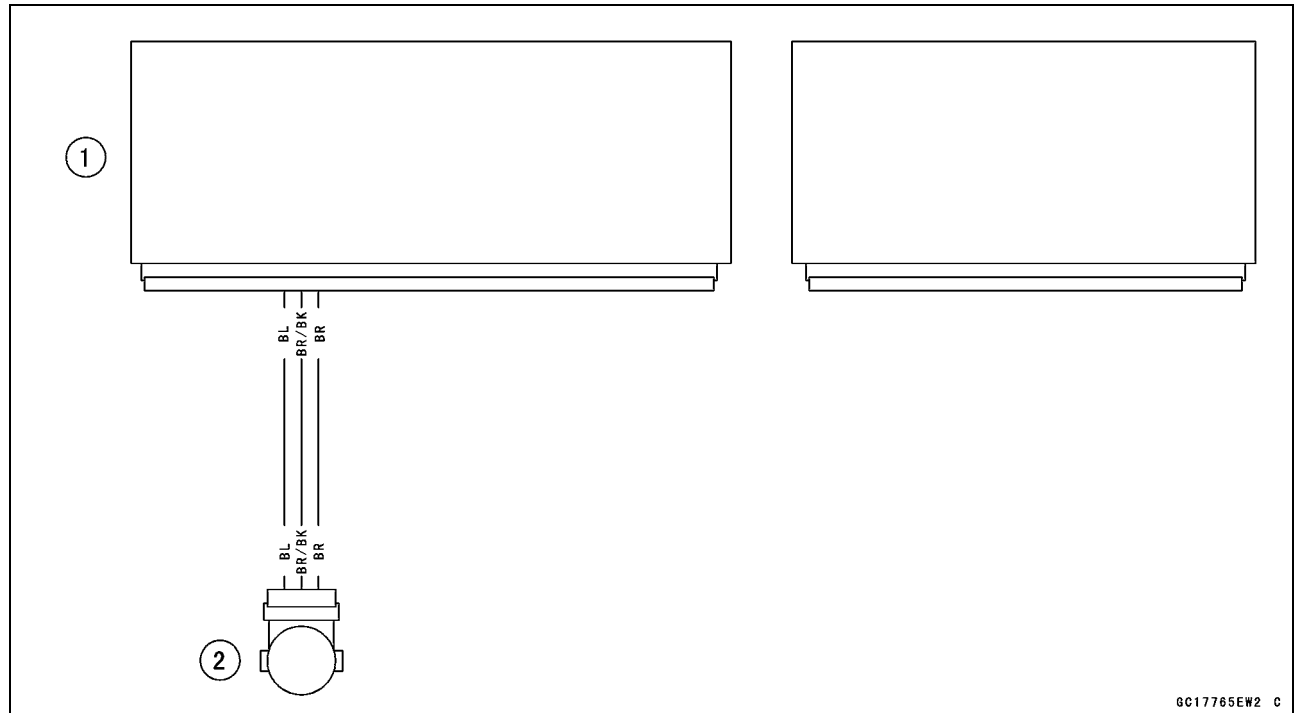

- 1. ECU
- 2. Subthrottle Sensor

3-78 FUEL SYSTEM (DFI)

Oxygen Sensor - not activated (Service Code 33, Equipped Models)

Oxygen Sensor Removal/Installation

- Refer to the Oxygen Sensor Removal/Installation in the Electrical System chapter.

Oxygen Sensor Inspection

- Warm up the engine thoroughly until the radiator fan starts.
- Turn the ignition switch OFF.
- Remove the right fairing (see Lower Fairing Removal in the Frame chapter).
- Open the clamp [A], and pull out the oxygen sensor lead connector [B].

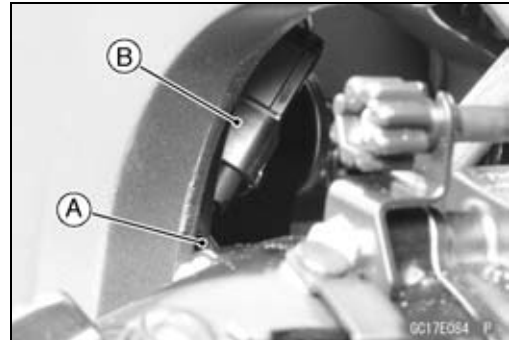

- Disconnect the oxygen sensor lead connector (4 pins connector) and connect the harness adapter [A] between these connectors.
[B] Main Harness
[C] Oxygen Sensor



Special Tool - Measuring Adapter: 57001-1700

- Connect a digital meter [D] to the harness adapter leads.

Oxygen Sensor Output Voltage

Connections to Adapter:

Digital Meter (+) → R (sensor BL) lead

Digital Meter (-) → BK (sensor W) lead

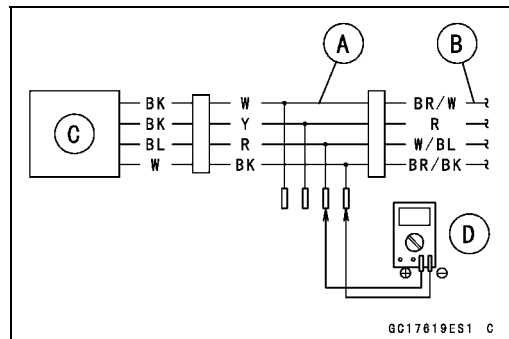

- Remove:
Air Cleaner Housing (see Air Cleaner Housing Removal)

- Disconnect the stick coil connectors [A].
- Separate the air switching valve hoses [B] from the air suction valve covers.
- Do not disconnect the air switching valve connector [C].

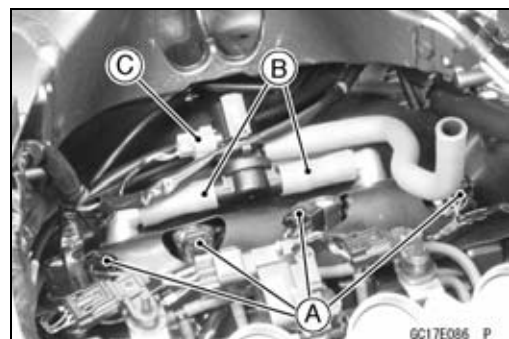

Oxygen Sensor - not activated (Service Code 33, Equipped Models)

- Install the suitable plugs [A] on the fitting of the air suction valve covers, and shut off the secondary air.
- Connect the stick coil connectors.
- Install the air cleaner housing temporarily (see Air Cleaner Housing Installation).

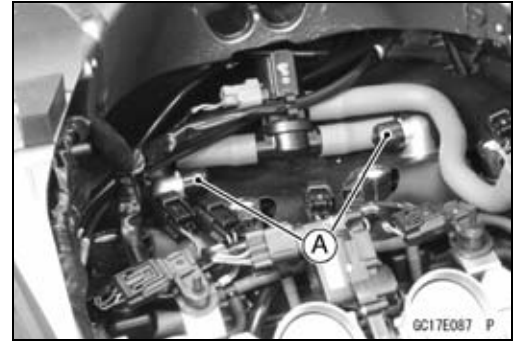

- Remove the fuel hose (see Fuel Hose Replacement in the Periodic Maintenance chapter).
- Connect the following parts temporary.
 - Fuel Pump Lead Connector [A]
 - Fuel Hose [B]

Special Tool - Fuel Hose: 57001-1607

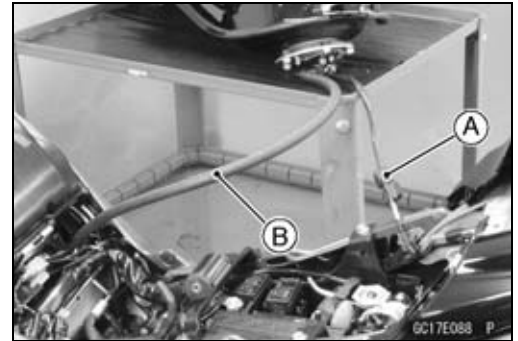

- Start the engine, and let it idle.
- Measure the output voltage with the connector joined.

Output Voltage (with Plugs)
Standard: DC 0.7 V or more

- Next, remove the air cleaner housing to take out the plugs from the fittings [A] of the air suction valve covers.
- Install the air cleaner housing.
- Start the engine, and let it idle.
- Measure the output voltage with the connector joined.

Output Voltage (without Plugs)
Standard: DC 0.2 V or less

- Turn the ignition switch OFF.

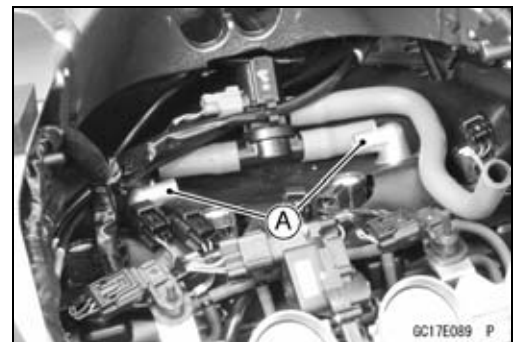

- ★ If the reading is out of the standard (with plugs: DC 0.7 V or more, without plugs: DC 0.2 V or less), remove the ECU and check the wiring for continuity between main harness connectors.
- Disconnect the ECU and sensor connectors.

Wiring Inspection

ECU Connectors [A] ↔

Oxygen Sensor Connector [B]

W/BL lead (ECU terminal 32) [C]

BR/BK lead (ECU terminal 33) [D]

- ★ If the wiring is good, replace the sensor.
- ★ If the reading is within the standard (with plugs: DC 0.7 V or more, without plugs: DC 0.2 V or less), check the ECU for its ground and power supply (see ECU Power Supply Inspection).
- ★ If the ground and power supply are good, replace the ECU (see ECU Removal/Installation).

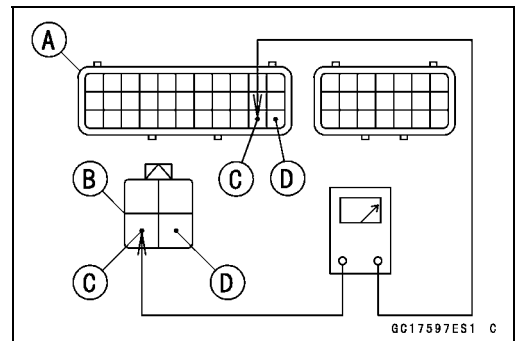

3-80 FUEL SYSTEM (DFI)

Oxygen Sensor - not activated (Service Code 33, Equipped Models)

Oxygen Sensor Circuit

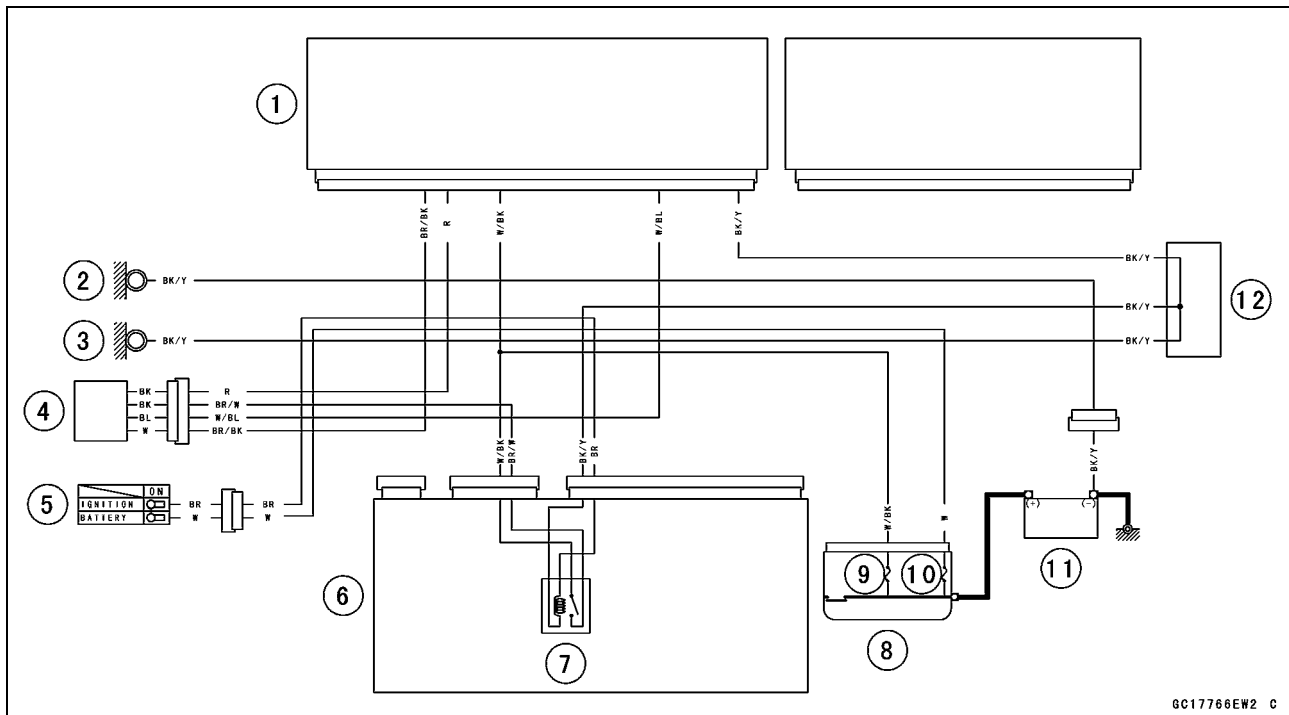

1. ECU
2. Meter Ground
3. Frame Ground
4. Oxygen Sensor
5. Ignition Switch
6. Relay Box
7. ECU Main Relay
8. Starter Relay
9. FI Fuse 15 A
10. Main Fuse 30 A
11. Battery 12 V 8 Ah
12. Water-proof Joint C

Exhaust Butterfly Valve Actuator Sensor (Service Code 34)

Exhaust Butterfly Valve Actuator Sensor Removal/Installation

The exhaust butterfly valve actuator sensor is built in the exhaust butterfly valve actuator. So, the sensor itself can not be removed. Remove the exhaust butterfly valve actuator (see Exhaust Butterfly Valve Actuator Removal).

Exhaust Butterfly Valve Actuator Sensor Input Voltage Inspection

NOTE

○Be sure the battery is fully charged.

- Turn the ignition switch OFF.
- Remove the front seat (see Front Seat Removal in the Frame chapter).
- Disconnect the exhaust butterfly valve actuator sensor lead connector (3 pins connector) and connect the harness adapter [A] between these connector.

Special Tool - Throttle Sensor Setting Adapter #1: 57001-1400

- Connect a digital meter to the harness adapter leads.

Exhaust Butterfly Valve Actuator Sensor Input Voltage Connections to Adapter:

Digital Meter (+) → Y/W (actuator W) lead

Digital Meter (-) → BK/BL (actuator BK) lead

- Measure the input voltage with the engine stopped and with the connector joined.
- Turn the ignition switch ON.

Input Voltage

Standard: DC 4.75 ~ 5.25 V

- Turn the ignition switch OFF.
- ★ If the reading is within the standard, check the output voltage (see Exhaust Butterfly Valve Actuator Sensor Output Voltage Inspection).
- ★ If the reading is out of the standard, remove the ECU and check the wiring for continuity between main harness connectors.
- Disconnect the ECU and sensor connectors.

Wiring Inspection

ECU Connector [A] ←→

Exhaust Butterfly Valve Actuator Sensor Connector [B]

BL lead (ECU terminal 5) [C]

BR/BK lead (ECU terminal 33) [D]

- ★ If the wiring is good, check the ECU for its ground and power supply (see ECU Power Supply Inspection).
- ★ If the ground and power supply are good, replace the ECU (see ECU Removal/Installation).

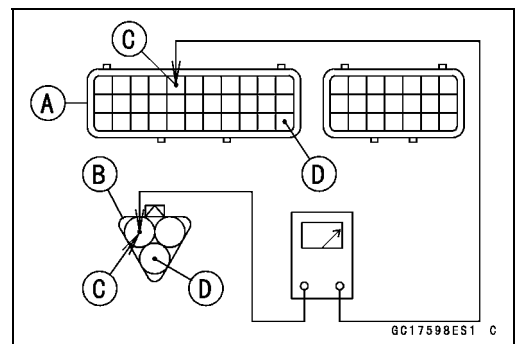
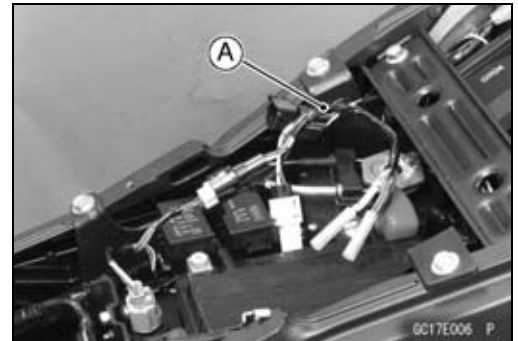

3-82 FUEL SYSTEM (DFI)

Exhaust Butterfly Valve Actuator Sensor (Service Code 34)

Exhaust Butterfly Valve Actuator Sensor Output Voltage Inspection

NOTE

○ Before this inspection, confirm the pulley [A] is original position (see Exhaust Butterfly Valve Actuator Installation).

- Disconnect:
 - 2 pins Connector [B]
 - 3 pins Connector [C]
- Connect the harness adapter [A] between the 3 pins connectors.

Special Tool - Throttle Sensor Setting Adapter #1: 57001-1400

- Connect a digital meter to the harness adapter leads.

Exhaust Butterfly Valve Actuator Sensor Output Voltage Connections to Adapter:

Digital Meter (+) → BL (actuator Y) lead

Digital Meter (-) → BK/BL (actuator BK) lead

- Measure the output voltage at the 3 pins connector of the exhaust butterfly valve actuator when the pulley is original position.
- Turn the ignition switch ON.

Output Voltage

Standard: DC 3.46 ~ 3.76 V at pulley original position

- Turn the ignition switch OFF.
- ★ If the reading is out of the standard, check the exhaust butterfly valve actuator sensor resistance (see Exhaust Butterfly Valve Actuator Sensor Resistance Inspection).
- ★ If the reading is within the standard, remove the ECU and check the wiring for continuity between main harness connectors.
- Disconnect the ECU and sensor connectors.

Wiring Inspection

ECU Connector [A] ←→

Exhaust Butterfly Valve Actuator Sensor Connector [B]

R/BK lead (ECU terminal 28) [C]

BR/BK lead (ECU terminal 33) [D]

- ★ If the wiring is good, check the ECU for its ground and power supply (see ECU Power Supply Inspection).
- ★ If the ground and power supply are good, replace the ECU (see ECU Removal/Installation).

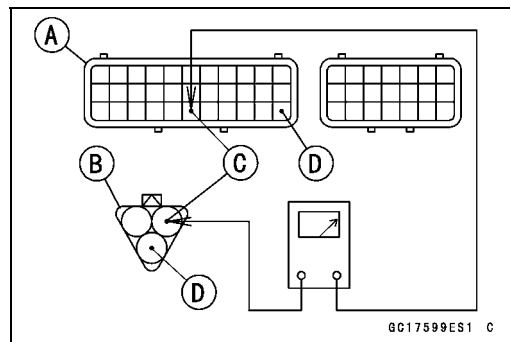
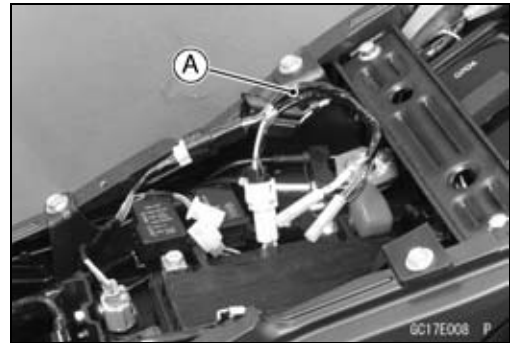
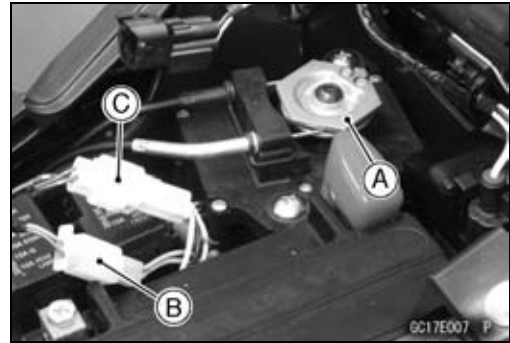

Exhaust Butterfly Valve Actuator Sensor (Service Code 34)

Exhaust Butterfly Valve Actuator Sensor Resistance Inspection

- Turn the ignition switch OFF.
- Disconnect the exhaust butterfly valve actuator sensor connector (3 pins connector) [A].
- Connect a digital meter [B] to the exhaust butterfly valve actuator sensor connector.
- Measure the exhaust butterfly valve actuator sensor resistance.

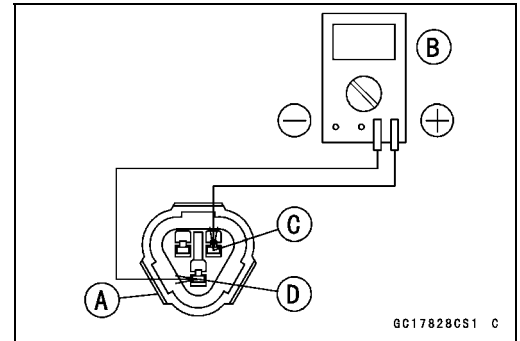

Exhaust Butterfly Valve Actuator Sensor Resistance

Connections: W lead [C] ↔ BK lead [D]

Standard: 4 ~ 6 kΩ

- ★ If the reading is out of the standard, replace the exhaust butterfly valve actuator.
- ★ If the reading within the standard, but the problem still exists, replace the ECU (see ECU Removal/Installation).

Exhaust Butterfly Valve Actuator Sensor Circuit

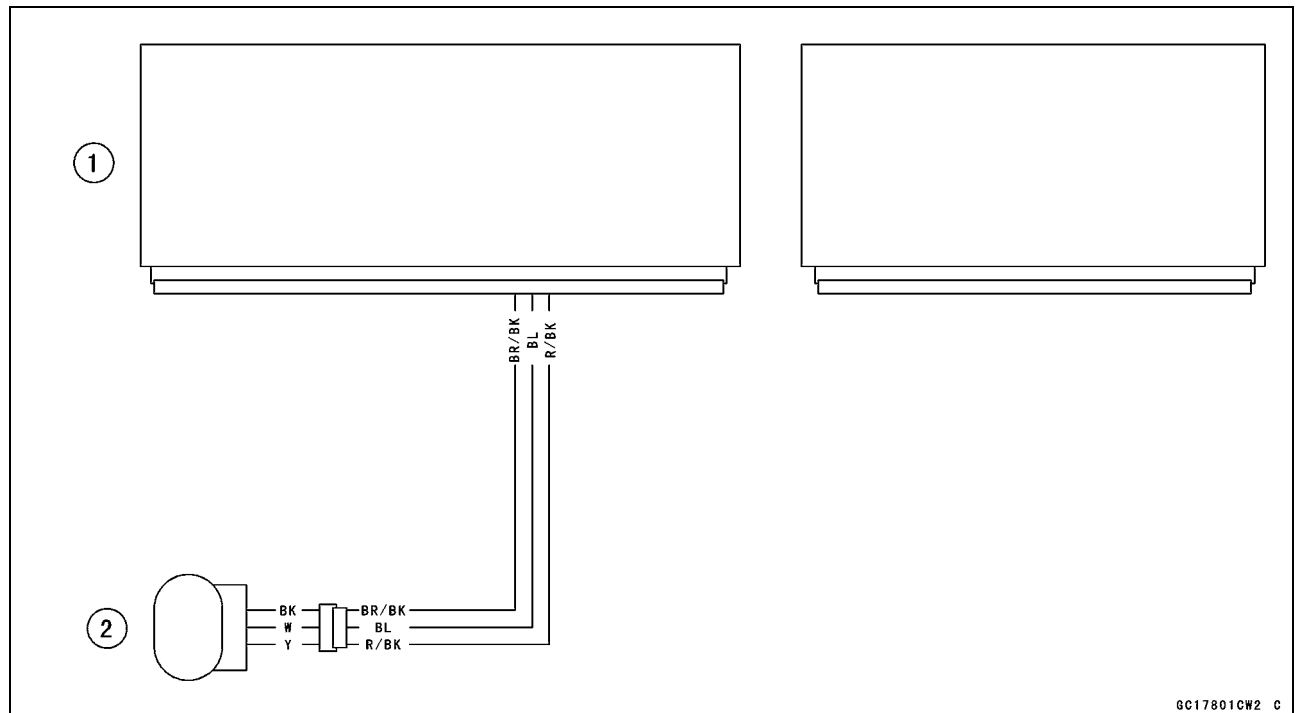

1. ECU
2. Exhaust Butterfly Valve Actuator

3-84 FUEL SYSTEM (DFI)

Immobilizer Amplifier (Service Code 35, Equipped Models)

Antenna Resistance Inspection

- Turn the ignition switch OFF.
- Remove the left lower fairing (see Lower Fairing Removal in the Frame chapter).
- Remove the band [A].



- Disconnect the antenna lead connector [A].
- Measure the antenna resistance.

Antenna Resistance

Connections: BK lead ↔ BK/W lead

Standard: About 3.0 ~ 4.6 Ω

- ★ If the reading is out of the standard, replace the antenna (see Immobilizer System Parts Replacement in the Electrical System chapter).
- ★ If the reading is within the standard, check the wiring to the amplifier (see wiring diagram in next section).
- ★ If the wiring is good, check the input voltage of the amplifier (see Amplifier Input Voltage Inspection).



Immobilizer Amplifier (Service Code 35, Equipped Models)

Amplifier Input Voltage Inspection

NOTE

○Be sure the battery is fully charged.

- Turn the ignition switch OFF.
- Remove the left lower fairing (see Lower Fairing Removal in the Frame chapter).
- Do not disconnect the connectors.
- Connect a digital meter to the amplifier connector [A] with needle adapter set.

Special Tool - Needle Adapter Set: 57001-1457

Amplifier Input Voltage

Connections to Amplifier Connector:

Digital Meter (+) → BR/W lead

Digital Meter (-) → BK/Y lead

- Measure the input voltage with the engine stopped and with the connector joined.
- Turn the ignition switch ON.

Input Voltage

Standard: Battery Voltage

- Turn the ignition switch OFF.
- ★ If the reading is out of the standard, check the wiring (see wiring diagram in next section).
- ★ If the reading is within the standard, check the wiring to ECU (see wiring diagram in next section).
- ★ If the wiring is good, replace the amplifier (see Immobilizer System Parts Replacement in the Electrical System chapter).

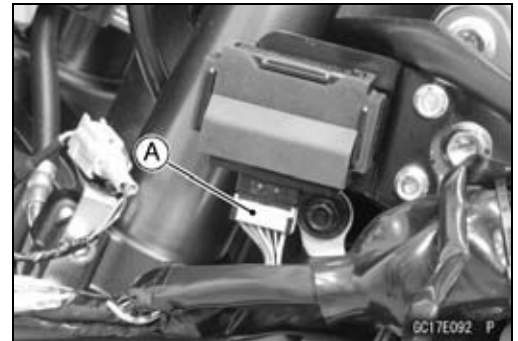

3-86 FUEL SYSTEM (DFI)

Blank Key Detection (Service Code 36, Equipped Models)

- This code appears in the following conditions.
- The transponder [A] in the ignition key is malfunction.
- When the spare ignition key of unregistration is used.
- When the ignition key is registered in the registered ECU.
- Therefore, the service code 36 will disappear when the above issue is solved.



Ignition Key Inspection

- Register the ignition key correctly (see Key Registration in the Electrical System chapter).
- ★ If the service code 36 appears again, the transponder in the key is malfunction, replace it.

Immobilizer System Circuit

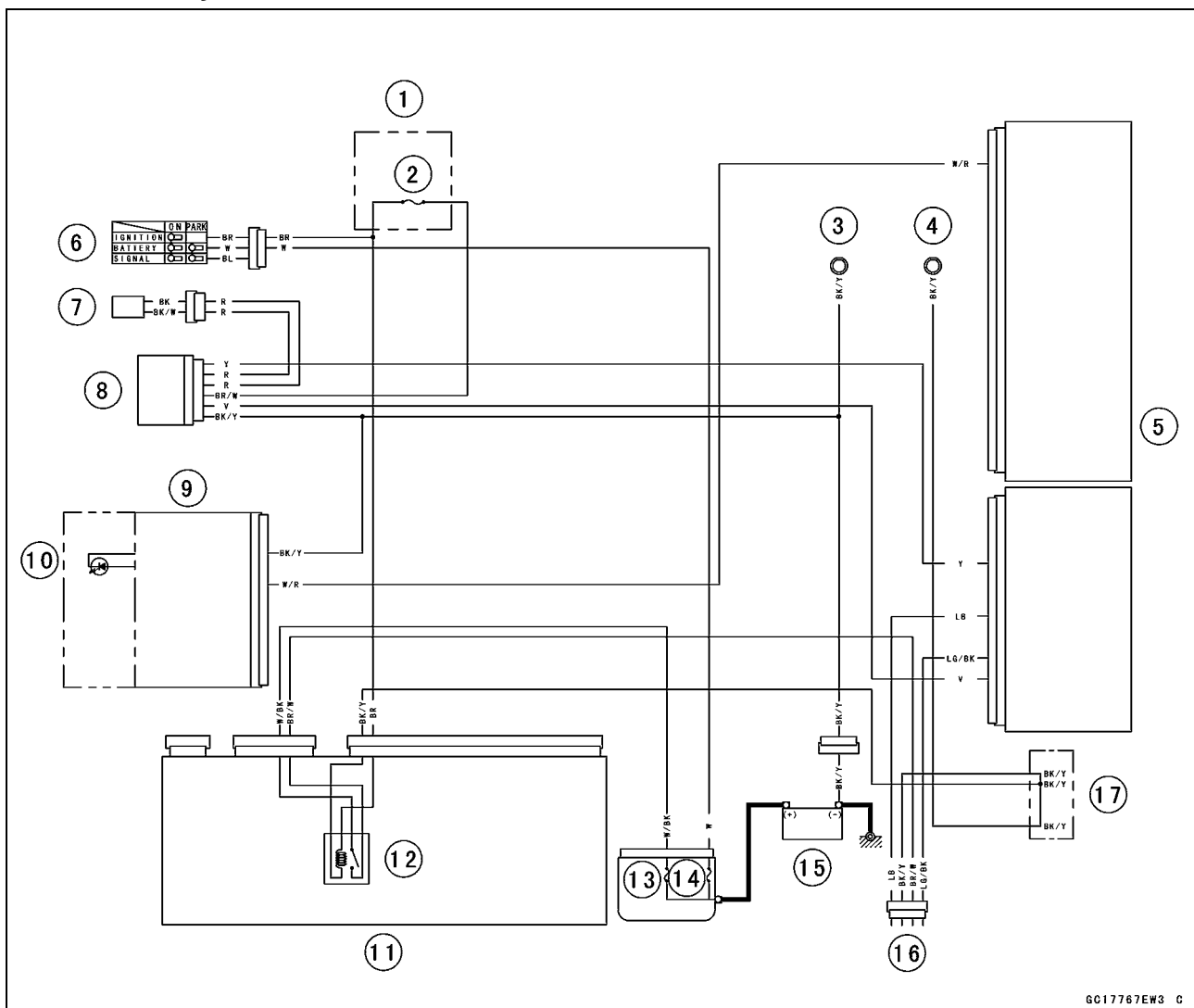

GC17767EW3 C

- | | | |
|------------------------|---|--|
| 1. Fuse Box | 8. Immobilizer Amplifier | 13. FI Fuse 15 A |
| 2. Ignition Fuse 15 A | 9. Meter Unit | 14. Main Fuse 30 A |
| 3. Meter Ground | 10. Oil Pressure/FI/Immobilizer Warning Indicator Light (LED) | 15. Battery 12 V 8 Ah |
| 4. Frame Ground | 11. Relay Box | 16. Immobilizer/Kawasaki Diagnostic System Connector |
| 5. ECU | 12. ECU Main Relay | 17. Water-proof Joint C |
| 6. Ignition Switch | | |
| 7. Immobilizer Antenna | | |

ECU Communication Error (Service Code 39)

ECU Communication Line Inspection

- When the data is not sent from the ECU to the meter unit for more than about 10 seconds, the service code 39 is displayed.
- The service code 39 is detected with meter unit.
- Remove the ECU and meter unit, check the wiring for continuity between main harness connector.
- Disconnect the ECU and meter unit connectors.

Wiring Inspection

ECU Connector [A] ↔ Meter Unit Connector [B]

W/R lead (ECU terminal 31) [C]

- ★ If the wiring is good, check the meter unit (see Meter Unit Inspection in the Electrical System chapter).
- ★ If the meter unit is normal, replace the ECU (see ECU Removal/Installation).

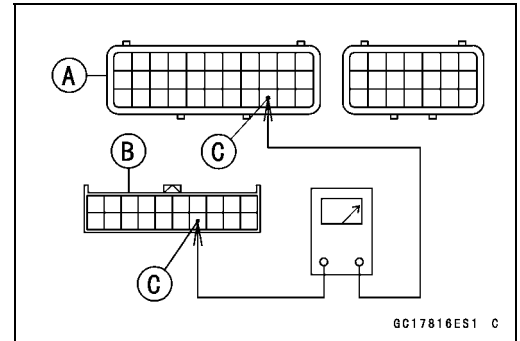

ECU Communication Line Circuit

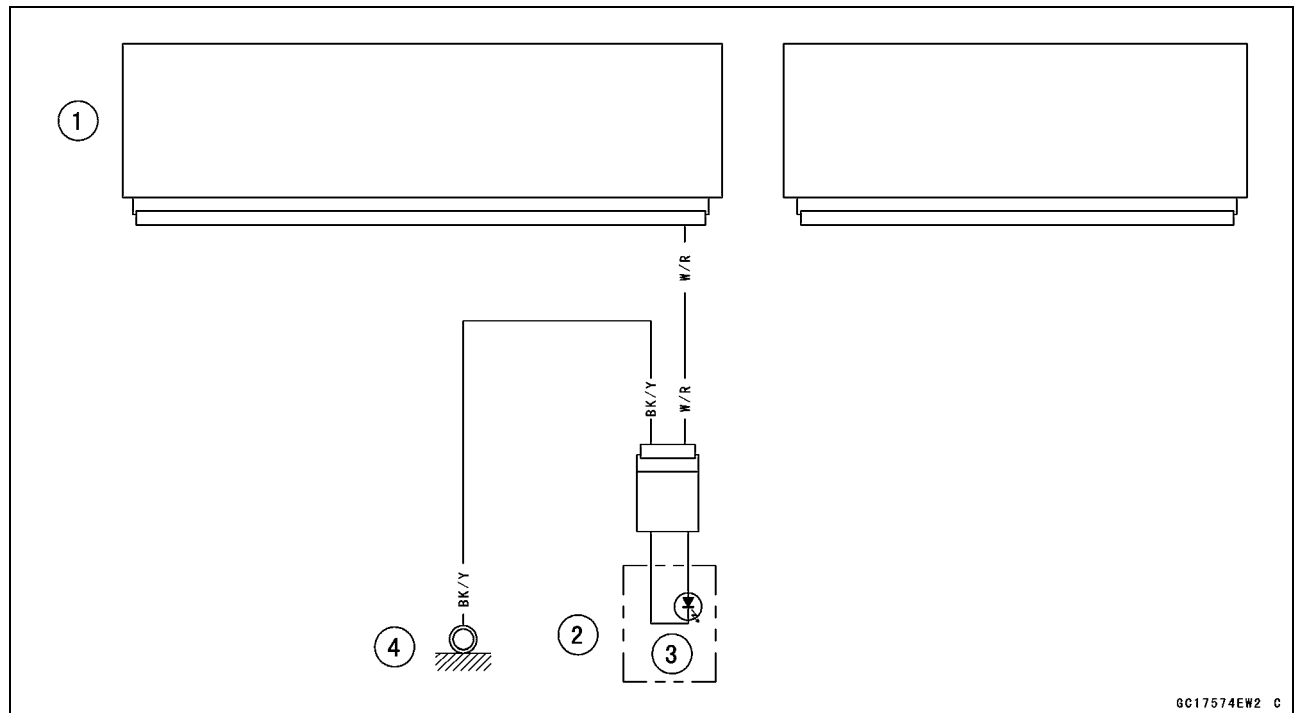

1. ECU
2. Meter Unit
3. Warning Indicator Light (LED)
4. Meter Ground

3-88 FUEL SYSTEM (DFI)

Stick Coils #1, #2, #3, #4 (Service Code 51, 52, 53, 54)

Stick Coil #1: Service Code 51

Stick Coil #2: Service Code 52

Stick Coil #3: Service Code 53

Stick Coil #4: Service Code 54

Stick Coil Removal/Installation

- Refer to the Stick Coil Removal/Installation in the Electrical System chapter.

Stick Coil Primary Winding Resistance Inspection

- Refer to the Stick Coil Inspection in the Electrical System chapter.
- ★ If the reading is within the standard, check the input voltage (see Stick Coil Input Voltage Inspection).

Stick Coil Input Voltage Inspection

NOTE

○ Be sure the battery is fully charged.

- Turn the ignition switch OFF.
- Remove the ECU (see ECU Removal).
- Do not disconnect the ECU connectors.
- Connect a digital meter [A] to the connector [B] with the needle adapter set.

Special Tool - Needle Adapter Set: 57001-1457

Stick Coil Input Voltage

Connections to ECU Connector:

For Stick Coil #1

Digital Meter (+) → BK lead (terminal 40)

Digital Meter (-) → BK/Y lead (terminal 54)

For Stick Coil #2

Digital Meter (+) → R/W lead (terminal 47)

Digital Meter (-) → BK/Y lead (terminal 54)

For Stick Coil #3

Digital Meter (+) → BK/W lead (terminal 39)

Digital Meter (-) → BK/Y lead (terminal 54)

For Stick Coil #4

Digital Meter (+) → BK/O lead (terminal 38)

Digital Meter (-) → BK/Y lead (terminal 54)

- Measure the input voltage to each primary winding of the stick coils with the engine stopped and with the connectors joined.
- Turn the engine stop switch to run position.
- Turn the ignition switch ON.

Input Voltage

Standard: Battery Voltage

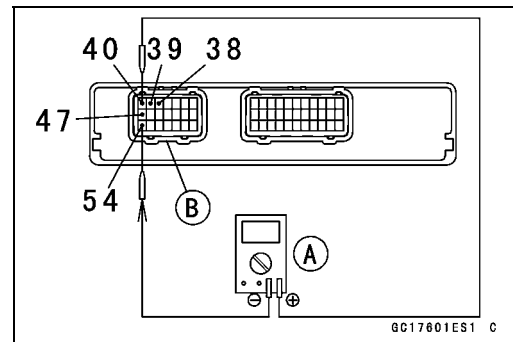

Stick Coils #1, #2, #3, #4 (Service Code 51, 52, 53, 54)

- Turn the ignition switch OFF.
- ★ If the input voltage is out of the standard, check the wiring for continuity (see wiring diagram in this section).
- ★ If the wiring is good, check the ECU for its ground and power supply (see ECU Power Supply Inspection).
- ★ If the ground and power supply are good, replace the ECU (see ECU Removal/Installation).
- ★ If the input voltage is within the standard, check the ECU for its ground and power supply (see ECU Power Supply Inspection).
- ★ If the ground and power supply are good, replace the ECU (see ECU Removal/Installation).

Stick Coil Circuit

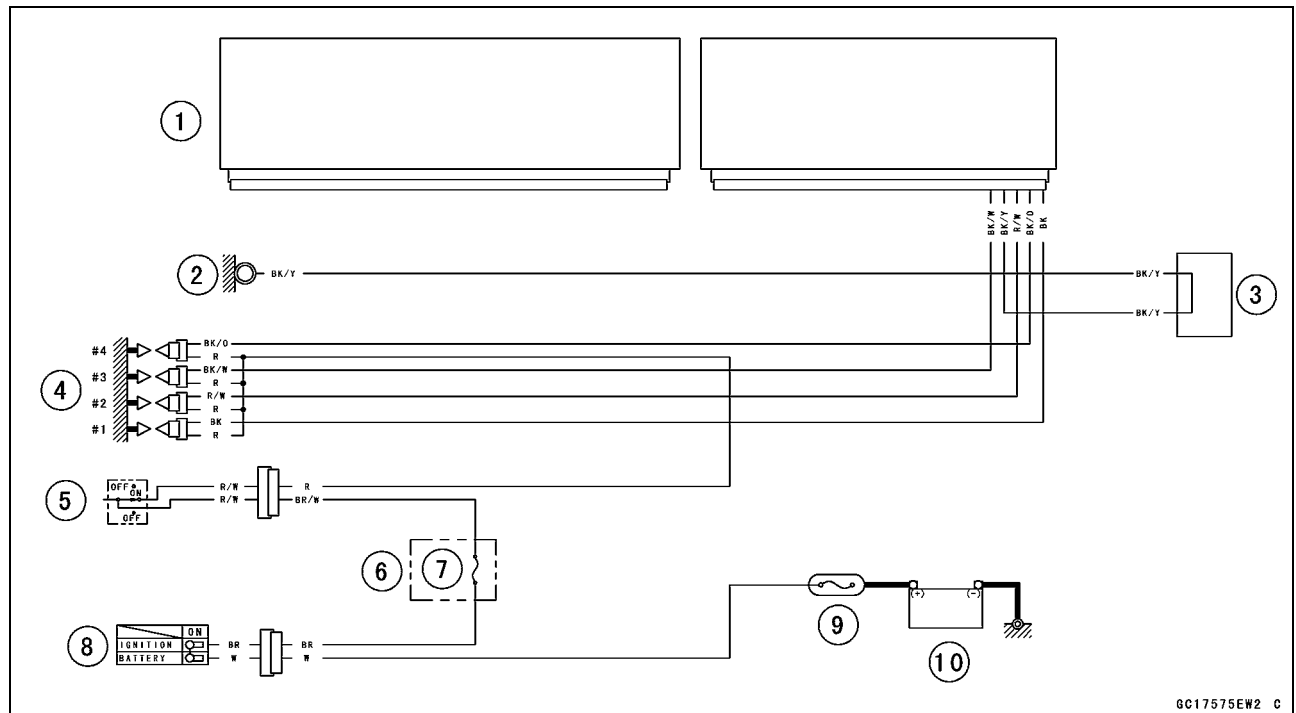

GC17575EW2 C

1. ECU
2. Frame Ground
3. Water-proof Joint C
4. Stick Coil #1, #2, #3, #4
5. Engine Stop Switch
6. Fuse Box 2
7. Ignition Fuse 15 A
8. Ignition Switch
9. Main Fuse 30 A
10. Battery 12 V 8 Ah

3-90 FUEL SYSTEM (DFI)

Radiator Fan Relay (Service Code 56)

Radiator Fan Relay Removal/Installation

- The radiator fan relay is built in the relay box [A].
- Refer to the Relay Box Removal in the Electrical System chapter.



Radiator Fan Relay Inspection

- Refer to the Relay Circuit Inspection in the Electrical System chapter.
- ★If the radiator fan relay is normal, check the wiring for continuity (see wiring diagram in this section).
- ★If the wiring is good, check the ECU for its ground and power supply (see ECU Power Supply Inspection).
- ★If the ground and power supply are good, replace the ECU (see ECU Removal/Installation).

Radiator Fan Relay Circuit

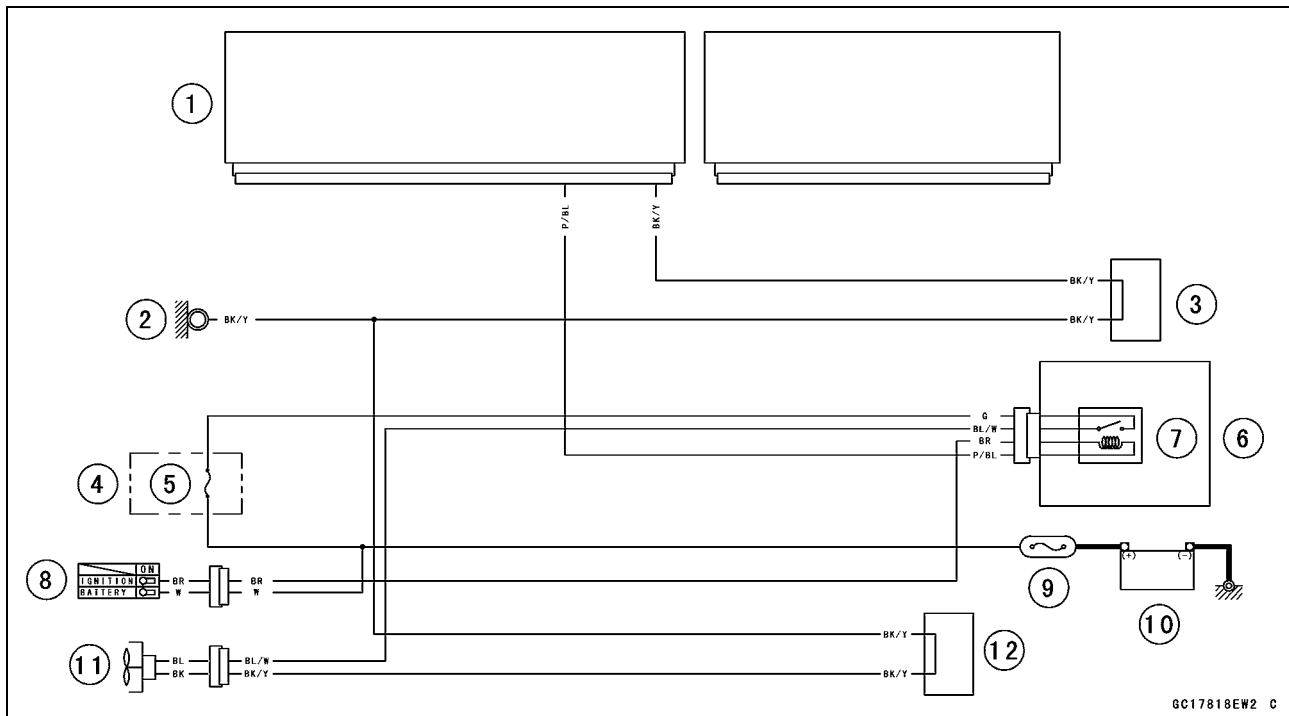

- | | |
|------------------------|-------------------------|
| 1. ECU | 7. Radiator Fan Relay |
| 2. Frame Ground | 8. Ignition Switch |
| 3. Water-proof Joint C | 9. Main Fuse 30 A |
| 4. Fuse Box 2 | 10. Battery 12 V 8 Ah |
| 5. Fan Fuse 15 A | 11. Radiator Fan Motor |
| 6. Relay Box | 12. Water-proof Joint A |

Subthrottle Valve Actuator (Service Code 62)

Subthrottle Valve Actuator Removal

NOTICE

Do not remove the subthrottle valve actuator [A] since it has been adjusted and set with precision at the factory.
 Never drop the throttle body assy especially on a hard surface. Such a shock to the subthrottle valve actuator can damage it.



Subthrottle Valve Actuator Inspection

NOTE

○Be sure the battery is fully charged.

- Remove the air cleaner housing (see Air Cleaner Housing Removal).
- Turn the ignition switch ON.
- Check to see that all the subthrottle valves [A] open and close smoothly.
- Turn the ignition switch OFF.
- ★ If the subthrottle valves do not operate, check the subthrottle valve actuator resistance (see Subthrottle Valve Actuator Resistance Inspection).

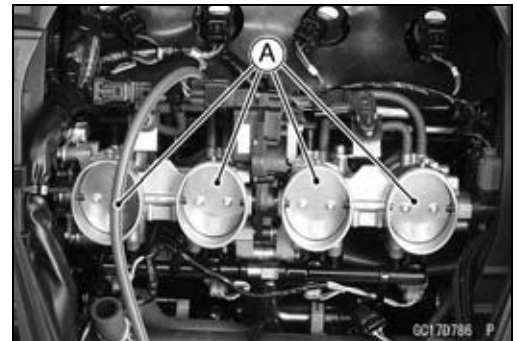

Subthrottle Valve Actuator Resistance Inspection

- Turn the ignition switch OFF.
- Disconnect the subthrottle valve actuator connector [A].



- Connect a digital meter to the subthrottle valve actuator connector [A].
- Measure the subthrottle valve actuator resistance.

Subthrottle Valve Actuator Resistance

Connections: LG/R lead [1] ↔ P/BL lead [2]

G lead [3] ↔ W/BL lead [4]

Standard: About 5.2 ~ 7.8 Ω

- ★ If the reading is out of the standard, replace the throttle body assy.
- ★ If the reading is within the standard, check the input voltage (see Subthrottle Valve Actuator Input Voltage Inspection).

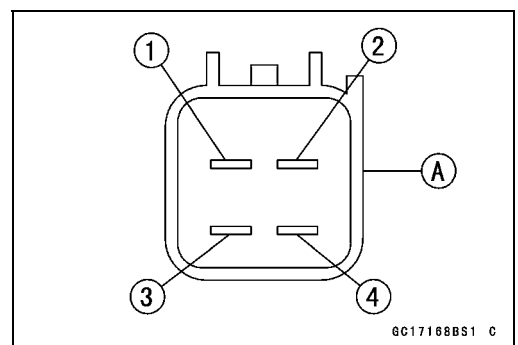

3-92 FUEL SYSTEM (DFI)

Subthrottle Valve Actuator (Service Code 62)

Subthrottle Valve Actuator Input Voltage Inspection

NOTE

○Be sure the battery is fully charged.

- Turn the ignition switch OFF.
- Disconnect the subthrottle valve actuator connector and connect the harness adapter [A] between these connectors as shown in the figure.

Main Harness [B]

Subthrottle Valve Actuator [C]

Special Tool - Measuring Adapter: 57001-1700

- Connect the peak voltage adapter [D] and a digital meter [E] to the harness adapter leads.

Special Tool - Peak Voltage Adapter: 57001-1415
Type: KEK-54-9-B

Subthrottle Valve Actuator Input Voltage Connections to Adapter:

(I) Digital Meter (+) → R (actuator W/BL) lead

Digital Meter (-) → Battery (-) terminal

(II) Digital Meter (+) → BK (actuator G) lead

Digital Meter (-) → Battery (-) terminal

(III) Digital Meter (+) → W (actuator P/BL) lead

Digital Meter (-) → Battery (-) terminal

(IV) Digital Meter (+) → Y (actuator LG/R) lead

Digital Meter (-) → Battery (-) terminal

- Measure the actuator input voltage with the engine stopped and with the connector joined.
- Turn the ignition switch ON.

Input Voltage

Standard: About DC 11.5 ~ 13.5 V

- Turn the ignition switch OFF.
- ★ If the reading is in specification, but the actuator does not operate, replace the throttle body assy.
- ★ If the reading is out of the specification, remove the ECU and check the wiring for continuity between main harness connector.

Special Tool - Hand Tester: 57001-1394

○ Disconnect the ECU and actuator connectors.

Wiring Continuity Inspection

ECU Connector [A] ↔

Subthrottle Valve Actuator Connector [B]

LG/R lead (ECU terminal 1) [C]

P/BL lead (ECU terminal 12) [D]

G lead (ECU terminal 23) [E]

W/BL lead (ECU terminal 24) [F]

- ★ If the wiring is good, check the ECU for its ground and power supply (see ECU Power Supply Inspection).
- ★ If the ground and power supply are good, replace the ECU (see ECU Removal/Installation).

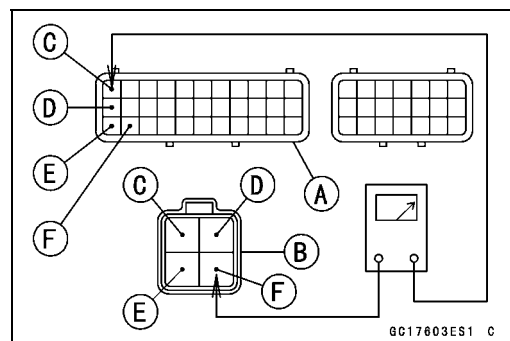
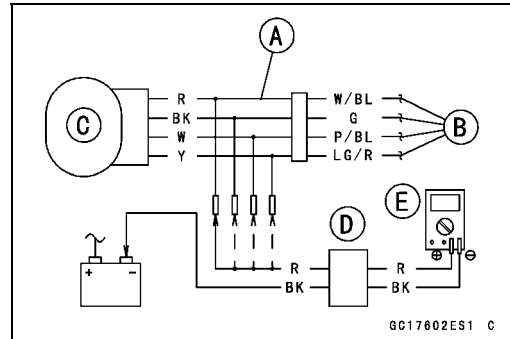
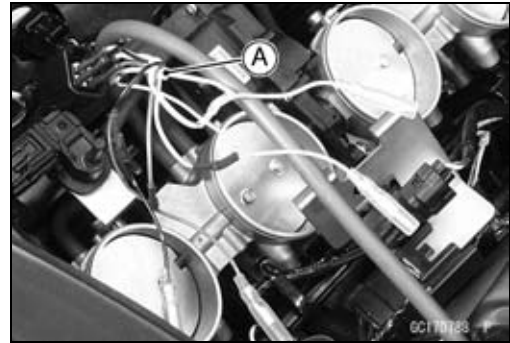

Subthrottle Valve Actuator (Service Code 62)

Subthrottle Valve Actuator Circuit

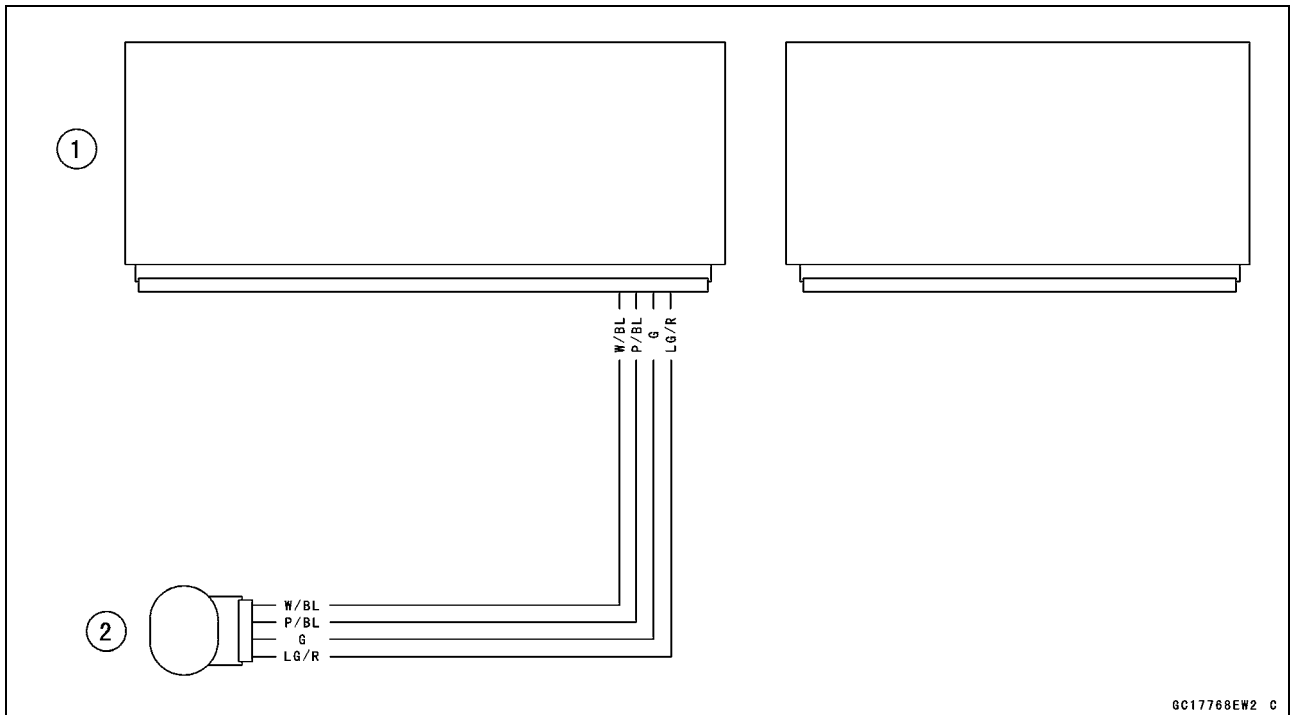

- 1. ECU
- 2. Subthrottle Valve Actuator

3-94 FUEL SYSTEM (DFI)

Exhaust Butterfly Valve Actuator (Service Code 63)

Exhaust Butterfly Valve Actuator Removal

NOTICE

Never drop the exhaust butterfly valve actuator especially on a hard surface. Such a shock to the actuator can damage it.

- Remove:
 - Front Seat (see Front Seat Removal in the Frame chapter)
 - Exhaust Butterfly Valve Cables (see Exhaust Butterfly Valve Cable Removal in the Engine Top End chapter)
 - Connectors [A]
 - Screws [B]
 - Exhaust Butterfly Valve Actuator [C]

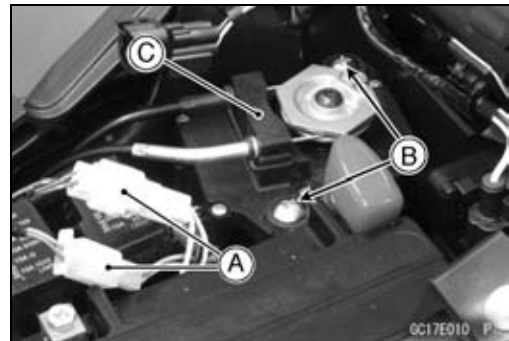

- Remove the pulley bolt while holding the pulley [A] with the suitable tool [B].

NOTICE

If the pulley bolt is removed without holding, the actuator damage will occur.

- Remove the pulley from the actuator.

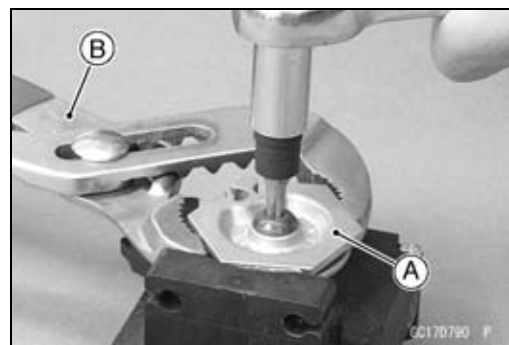

Exhaust Butterfly Valve Actuator Installation

- Install the pulley [A] on the actuator so that the hole side [B] align with the groove [C] on the shaft.
- Make sure that the groove on the shaft is pointing toward the center of the screw [D].
- If the shaft position is incorrect, refer to the following NOTE and procedures to electrically adjust the shaft position.

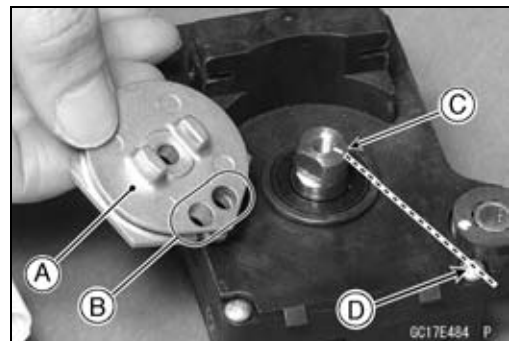

- Install the pulley [A] on the actuator as shown.
- Tighten the pulley bolt [B] while holding the pulley with the suitable tool [C].

Torque - Exhaust Butterfly Valve Actuator Pulley Bolt: 5.0 N-m (0.51 kgf-m, 44 in-lb)

NOTICE

If the pulley bolt is tightened without holding, the actuator damage will occur.

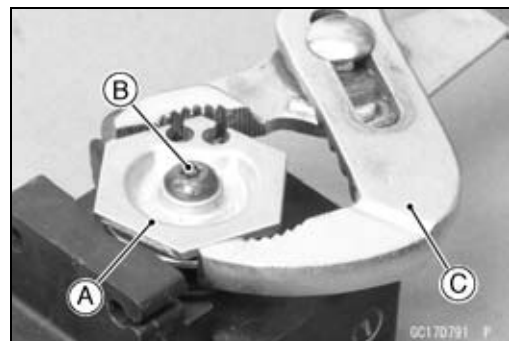

Exhaust Butterfly Valve Actuator (Service Code 63)

- After tightening the pulley bolt, confirm whether pulley [A] is an angle shown in the figure.
41.7° ±7° [B]
- This position is original position of the pulley.

NOTE

- *Correct the position electrically after confirming the use is discontinued and there is no damage when differing from the angle of shown in the figure.*

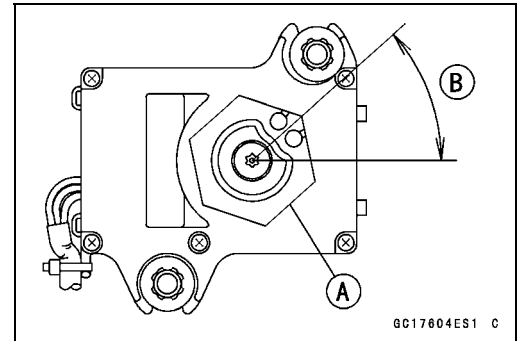

NOTICE

Do not correct the pulley position with the tool, forcibly. The actuator damage will occur.

- ★ If the pulley angle is wrong, adjust the angle as follows.
- Connect:
 - 2 pins Connector
 - 3 pins Connector
- Turn the ignition switch ON.
- Confirm the pulley turns clockwise or counterclockwise then it stops at the original position.

- ★ If the pulley position has not been returned to the original position, electrically adjust the shaft position as follows.

- Remove:
 - 2 pins Connector
 - 3 pins Connector
- Turn the pulley to the original position by turning it clockwise or counterclockwise by connecting the battery to the 2 pins connector terminals. To turn the pulley gradually, intermittently connect the battery positive (+) terminal to the 2 pins connector terminal while connecting the battery negative (-) terminal to the connector.
 - Pink (-) lead terminal [A]
 - Gray (+) lead terminal [B]

- Clockwise:
 - Pink (-) lead terminal to battery (-) terminal
 - Gray (+) lead terminal to battery (+) terminal

- Counterclockwise:
 - Pink (-) lead terminal to battery (+) terminal
 - Gray (+) lead terminal to battery (-) terminal

- Reconnect the 2 pins connector and 3 pins connector, and turn the ignition switch ON.
- Make sure that the pulley turns clockwise and then counterclockwise.
- The pulley should return to the original position.
- Turn the ignition switch OFF.

- ★ If the pulley does not return to the original position, check the exhaust butterfly valve actuator resistance (see Exhaust Butterfly Valve Actuator Resistance Inspection).

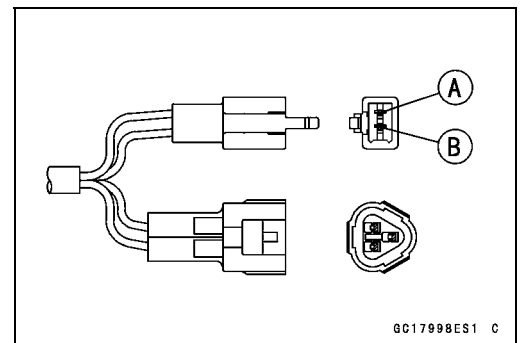

3-96 FUEL SYSTEM (DFI)

Exhaust Butterfly Valve Actuator (Service Code 63)

- Be sure to install the washers [A] on the exhaust butterfly valve actuator [B].
- Tighten:
 - Torque - Exhaust Butterfly Valve Actuator Mounting Screws [C]: 1.2 N ·m (0.12 kgf ·m, 11 in·lb)**
- Install the close cable first and then open cable (see Exhaust Butterfly Valve Cable Installation in the Engine Top End chapter).

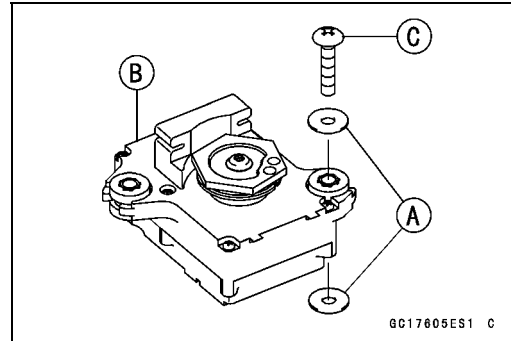

Exhaust Butterfly Valve Actuator Inspection

NOTE

○ Be sure the battery is fully charged

- Remove the front seat (see Front Seat Removal in the Frame chapter).
- Turn the ignition switch ON.
- In the left side view of the motorcycle, check to see the pulley [A] clockwise [B] and counterclockwise [C] smoothly.
- The pulley turns clockwise and then counterclockwise, and clockwise again.
- Turn the ignition switch OFF.
- ★ If the pulley does not operate, check the exhaust butterfly valve cable installation (see Butterfly Valve Cable Installation in the Engine Top End chapter) and the exhaust butterfly valve actuator resistance (see Exhaust Butterfly Valve Actuator Resistance Inspection).

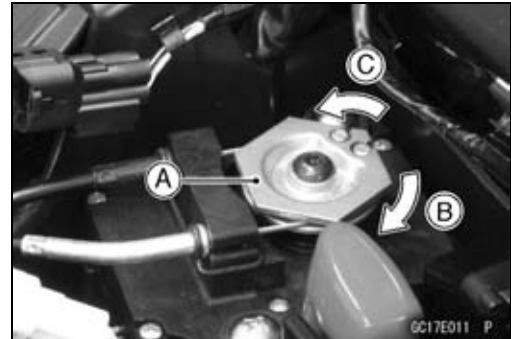

Exhaust Butterfly Valve Actuator Resistance Inspection

- Turn the ignition switch OFF.
- Disconnect the exhaust butterfly valve actuator lead connector (2 pins connector) [A].
- Set the hand tester to the $\times 1 \Omega$ range and connect it to the exhaust butterfly valve actuator connector.

Special Tool - Hand Tester: 57001-1394

- Measure the exhaust butterfly valve actuator resistance.

Exhaust Butterfly Valve Actuator Resistance

Connections: P lead \longleftrightarrow GY lead

Standard: Any Reading Resistance (reference 5 ~ 200 Ω)

- ★ If the reading is 0 or infinity (∞) Ω , replace the exhaust butterfly valve actuator.



Exhaust Butterfly Valve Actuator (Service Code 63)

★ If the reading is in specification, remove the ECU and check the wiring for continuity between main harness connectors.

○ Disconnect the ECU and actuator connectors.

Wiring Inspection

ECU Connector [A] ←→

Exhaust Butterfly Valve Actuator Connector [B]

GY lead (ECU terminal 2) [C]

G/R lead (ECU terminal 3) [D]

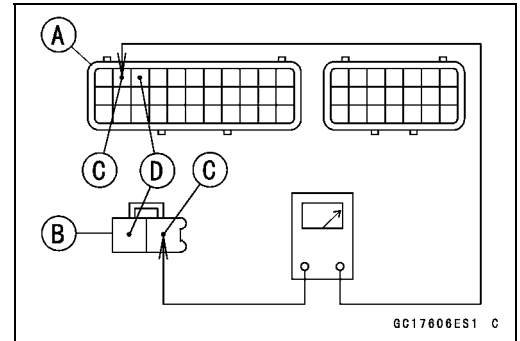

★ If the wiring is good, check the ECU for its ground and power supply (see ECU Power Supply Inspection).

★ If the ground and power supply are good, replace the ECU (see ECU Removal/Installation).

Exhaust Butterfly Valve Actuator Circuit

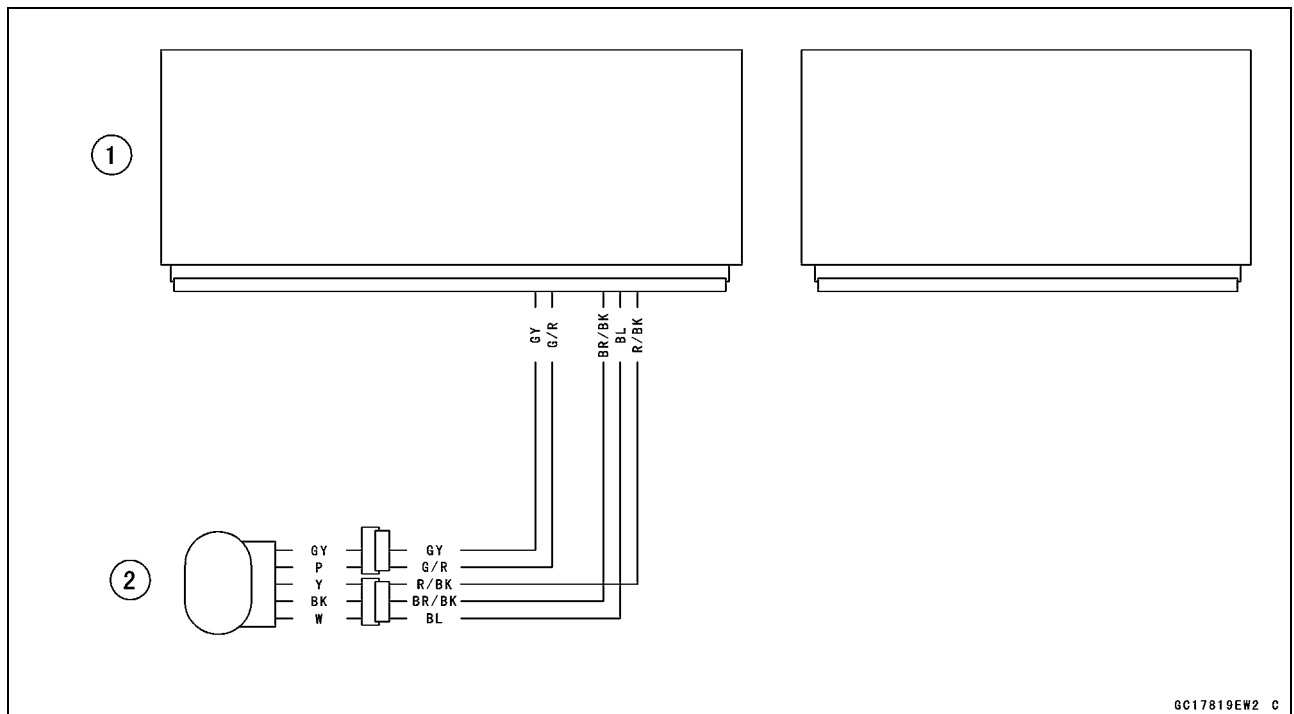

1. ECU
2. Exhaust Butterfly Valve Actuator

3-98 FUEL SYSTEM (DFI)

Air Switching Valve (Service Code 64)

Air Switching Valve Removal/Installation

● Refer to the Air Switching Valve Removal/Installation in the Engine Top End chapter.

Air Switching Valve Inspection

● Refer to the Air Switching Valve Unit Test in the Electrical System chapter.

★ If the air switching valve is normal, check the wiring for continuity (see wiring diagram in this section).

★ If the wiring is good, check the ECU for its ground and power supply (see ECU Power Supply Inspection).

★ If the ground and power supply are good, replace the ECU (see ECU Removal/Installation).

Air Switching Valve Circuit

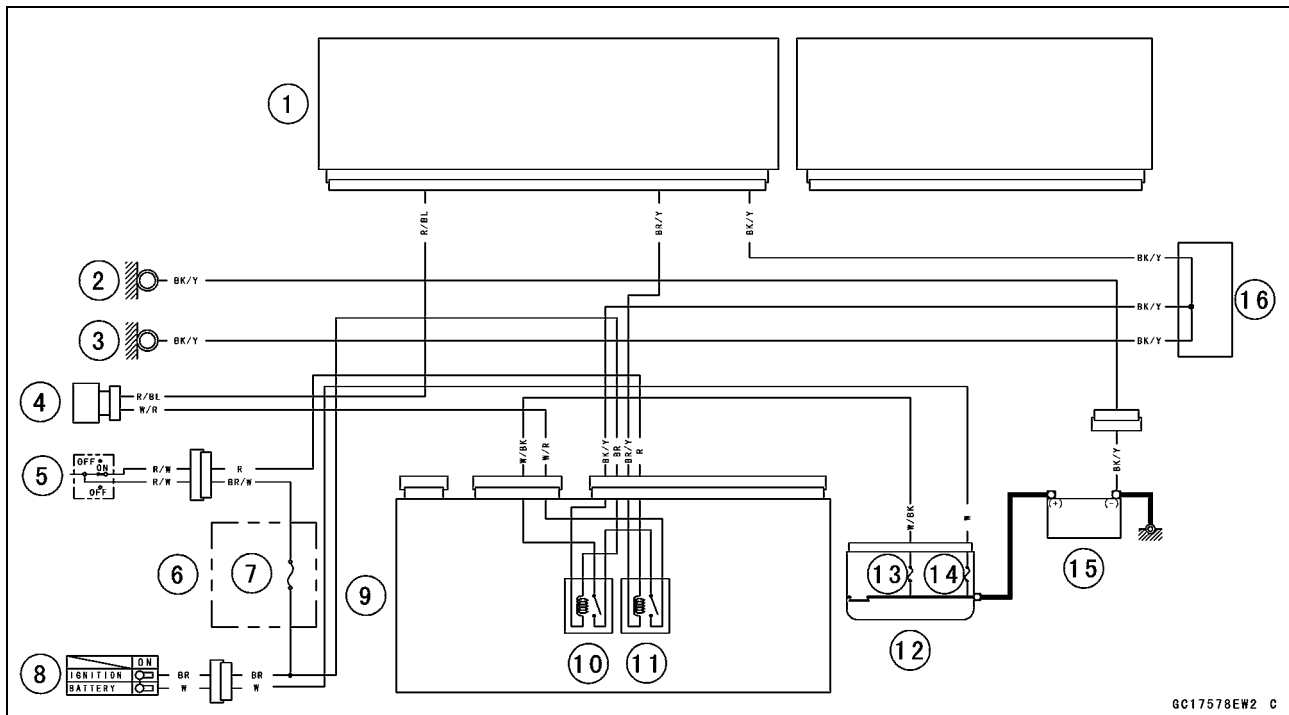

GC17578EW2 C

- | | |
|------------------------|-------------------------|
| 1. ECU | 9. Relay Box |
| 2. Meter Ground | 10. ECU Main Relay |
| 3. Frame Ground | 11. Fuel Pump Relay |
| 4. Air Switching Valve | 12. Starter Relay |
| 5. Engine Stop Switch | 13. FI Fuse 15 A |
| 6. Fuse Box 2 | 14. Main Fuse 30 A |
| 7. Ignition Fuse 15 A | 15. Battery 12 V 8 Ah |
| 8. Ignition Switch | 16. Water-proof Joint C |

Oxygen Sensor Heater (Service Code 67, Equipped Models)

Oxygen Sensor Heater Removal/Installation

The oxygen sensor heater is built in the oxygen sensor. So, the heater itself can not be removed. Remove the oxygen sensor (see Oxygen Sensor Removal (Equipped Models) in the Electrical System chapter).

Oxygen Sensor Heater Resistance Inspection

- Turn the ignition switch OFF.
- Remove the right lower fairing (see Lower Fairing Removal in the Frame chapter).
- Open the clamp [A], and pull out the oxygen sensor lead connector [B].
- Disconnect the oxygen sensor lead connector.

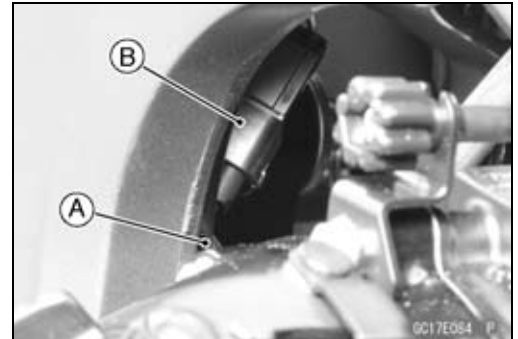

- Connect a digital meter [A] to the oxygen sensor lead connector [B].
- Measure the oxygen sensor heater resistance.

Oxygen Sensor Heaters Resistance

Connections: BK lead [C] ↔ BK lead [D]

Standard: 11.7 ~ 14.5 Ω at 20° C (68°F)

- ★ If the reading is out of the standard, replace the sensor.
- ★ If the reading is within the standard, check the power source voltage (see Oxygen Sensor Heater Power Source Voltage Inspection).

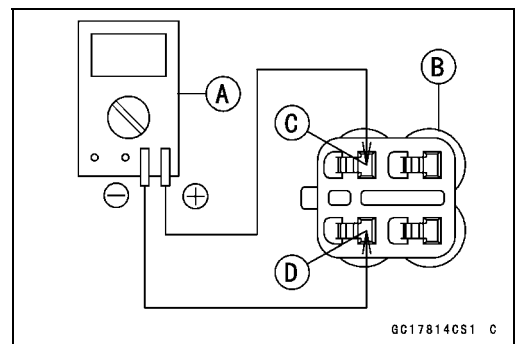

3-100 FUEL SYSTEM (DFI)

Oxygen Sensor Heater (Service Code 67, Equipped Models)

Oxygen Sensor Heater Power Source Voltage Inspection

NOTE

○ Be sure the battery is fully charged.

- Turn the ignition switch OFF.
- Disconnect the oxygen sensor lead connector and connect the harness adapter [A] between these connectors.
 - [B] Main Harness
 - [C] Oxygen Sensor

Special Tool - Measuring Adapter: 57001-1700

- Connect a digital meter [D] to the harness adapter lead.

Oxygen Sensor Power Source Voltage Connections to Adapter:

Digital Meter (+) → Y (sensor BK) lead

Digital Meter (-) → Battery (-) terminal

- Measure the power source voltage with the engine stopped and with the connector joined.
- Turn the ignition switch ON.

Power Source Voltage

Standard: Battery Voltage

- Turn the ignition switch OFF.
- ★ If the reading is in specification, but the problem still exists, replace the ECU (see ECU Removal/Installation).
- ★ If the reading is out of the standard, check the following.
 - FI Fuse 15 A (see Fuse Inspection in the Electrical System chapter)
 - Power Source Wiring (see wiring diagram in this section)
- ★ If the fuse and wiring are good, remove the ECU and check the wiring for continuity between main harness connectors.
- Disconnect the ECU and sensor connectors.

Wiring Inspection

ECU Connector [A] ↔

Oxygen Sensor Connector [B]

R lead (ECU terminal 9) [C]

- ★ If the wiring is good, check the ECU for its ground and power supply (see ECU Power Supply Inspection).
- ★ If the ground and power supply are good, replace the ECU (see ECU Removal/Installation).

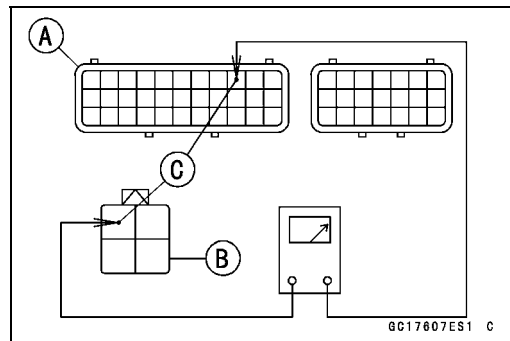
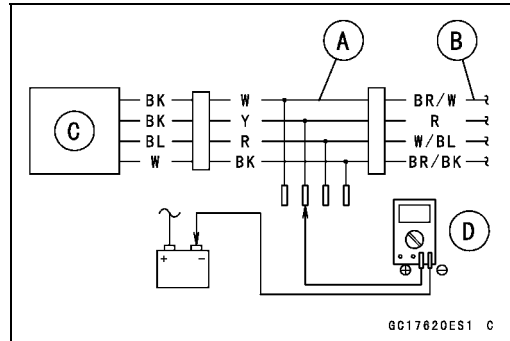
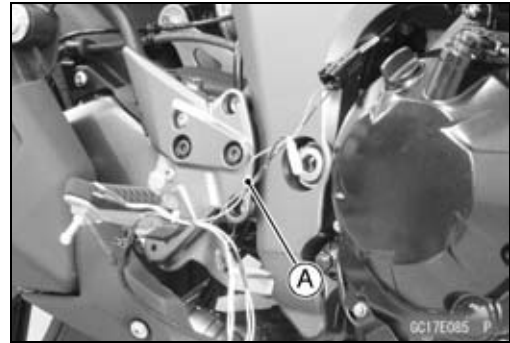

Oxygen Sensor Heater (Service Code 67, Equipped Models)

Oxygen Sensor Circuit

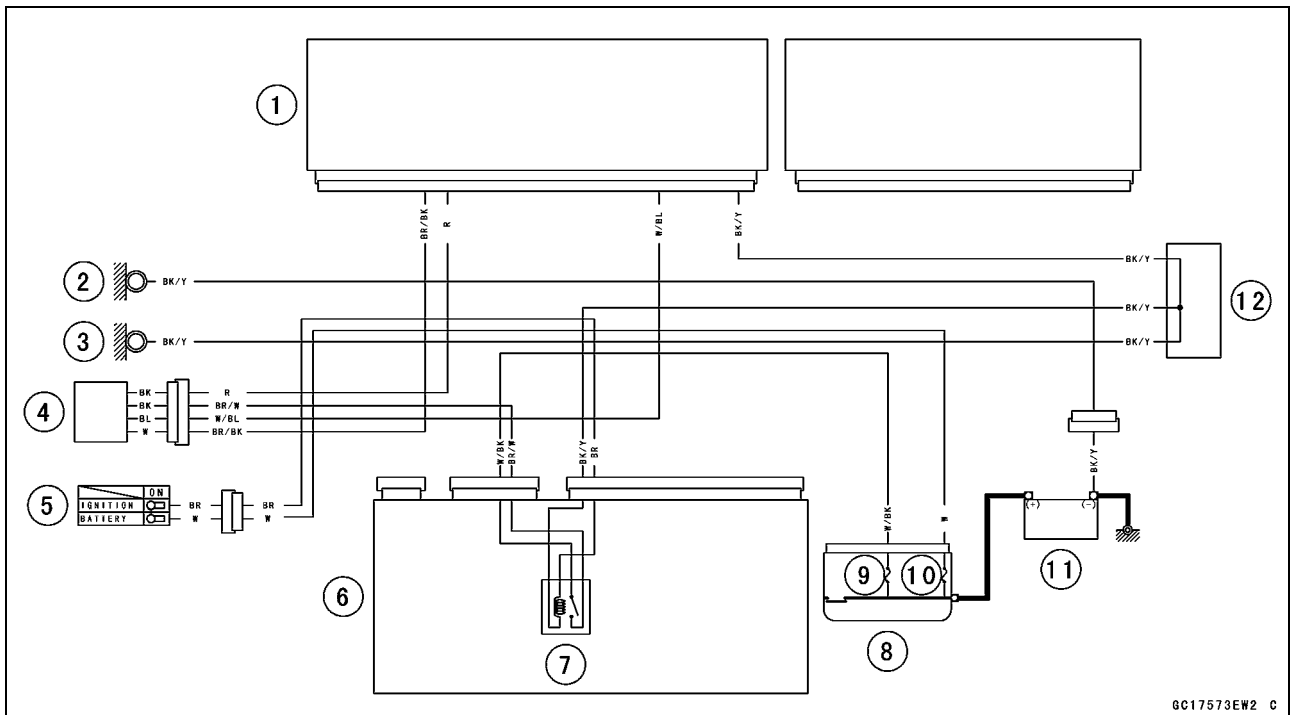

GC17573EW2 C

1. ECU
2. Meter Ground
3. Frame Ground
4. Oxygen Sensor
5. Ignition Switch
6. Relay Box
7. ECU Main Relay
8. Starter Relay
9. FI Fuse 15 A
10. Main Fuse 30 A
11. Battery 12 V 8 Ah
12. Water-proof Joint C

3-102 FUEL SYSTEM (DFI)

Oxygen Sensor - Incorrect Output Voltage (Service Code 94, Equipped Models)

Oxygen Sensor Removal/Installation

- Refer to the Oxygen Sensor Removal/Installation in the Electrical System chapter.

Oxygen Sensor Inspection

- Warm up the engine thoroughly until the radiator fan starts.
- Turn the ignition switch OFF.
- Remove the right lower fairing (see Lower Fairing Removal in the Frame chapter).
- Open the clamp [A], and pull out the oxygen sensor lead connector [B].

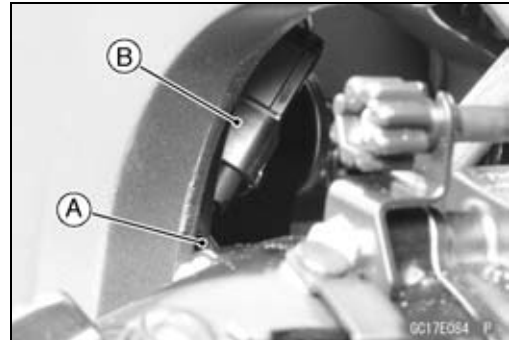

- Disconnect the oxygen sensor lead connector (4 pins connector) and connect the harness adapter [A] between these connectors.
[B] Main Harness
[C] Oxygen Sensor



Special Tool - Measuring Adapter: 57001-1700

- Connect a digital meter [D] to the harness adapter leads.

Oxygen Sensor Output Voltage

Connections to Adapter:

Digital Meter (+) → R (sensor BL) lead

Digital Meter (-) → BK (sensor W) lead

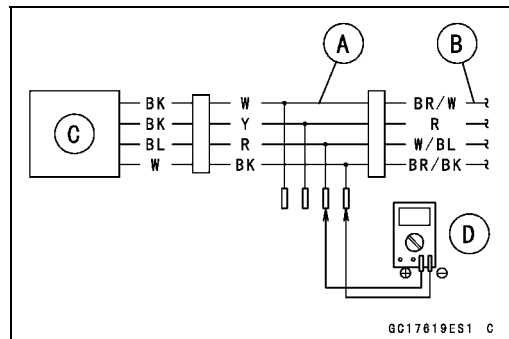

- Remove:
Air Cleaner Housing (see Air Cleaner Housing Removal)
- Disconnect the stick coil connectors [A].
- Separate the air switching valve hoses [B] from the air suction valve covers.
- Do not disconnect the air switching valve connector [C].

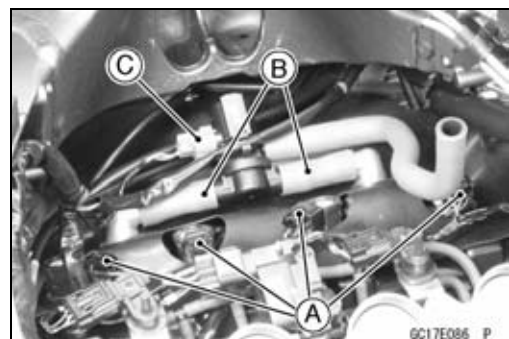

Oxygen Sensor - Incorrect Output Voltage (Service Code 94, Equipped Models)

- Install the suitable plugs [A] on the fitting of the air suction valve covers, and shut off the secondary air.
- Connect the stick coil connectors.
- Install the air cleaner housing temporarily (see Air Cleaner Housing Installation).

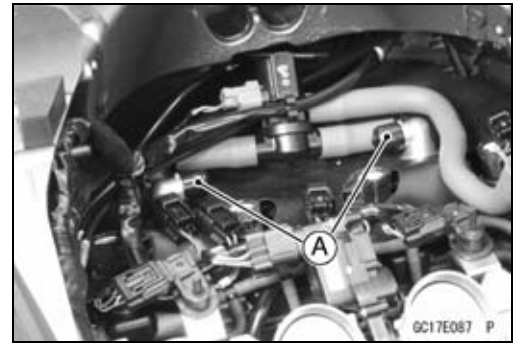

- Remove the fuel hose (see Fuel Hose Replacement in the Periodic Maintenance chapter).
- Connect the following parts temporary.
 - Fuel Pump Lead Connector [A]
 - Fuel Hose [B]

Special Tool - Fuel Hose: 57001-1607

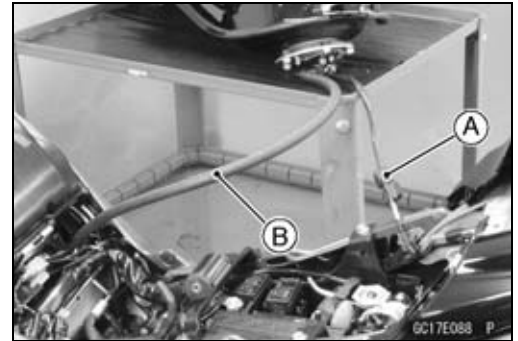

- Start the engine, and let it idle.
- Measure the output voltage with the connector joined.

Output Voltage (with Plugs, Rich)
Standard: DC 0.7 V or more

- Next, remove the air cleaner housing to take out the plugs from the fittings [A] of the air suction valve covers.
- Install the air cleaner housing.
- Start the engine, and let it idle.
- Measure the output voltage with the connector joined.

Output Voltage (without Plugs, Lean)
Standard: DC 0.2 V or less

- Turn the ignition switch OFF.

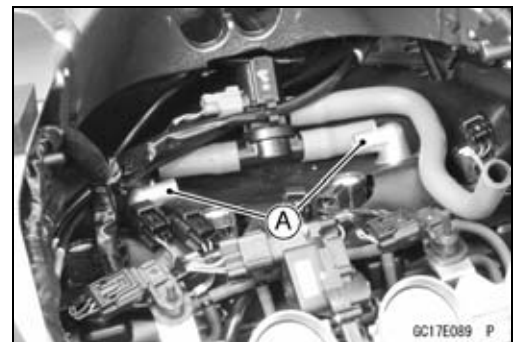

- ★ If the reading is out of the standard (with plugs: DC 0.7 V or more, without plugs: DC 0.2 V or less), check the following.

- Fuel Pressure (see Fuel Pressure Inspection)
- Fuel Injector (see Fuel Injectors section)

- ★ If the fuel pressure and fuel injectors are good, replace the sensor.

- ★ If the reading is within the standard (with plugs: DC 0.7 V or more, without plugs: DC 0.2 V or less), check the ECU for its ground and power supply (see ECU Power Supply Inspection).

- ★ If the ground and power supply are good, replace the ECU (see ECU Removal/Installation).

3-104 FUEL SYSTEM (DFI)

Oxygen Sensor - Incorrect Output Voltage (Service Code 94, Equipped Models)

Oxygen Sensor Circuit

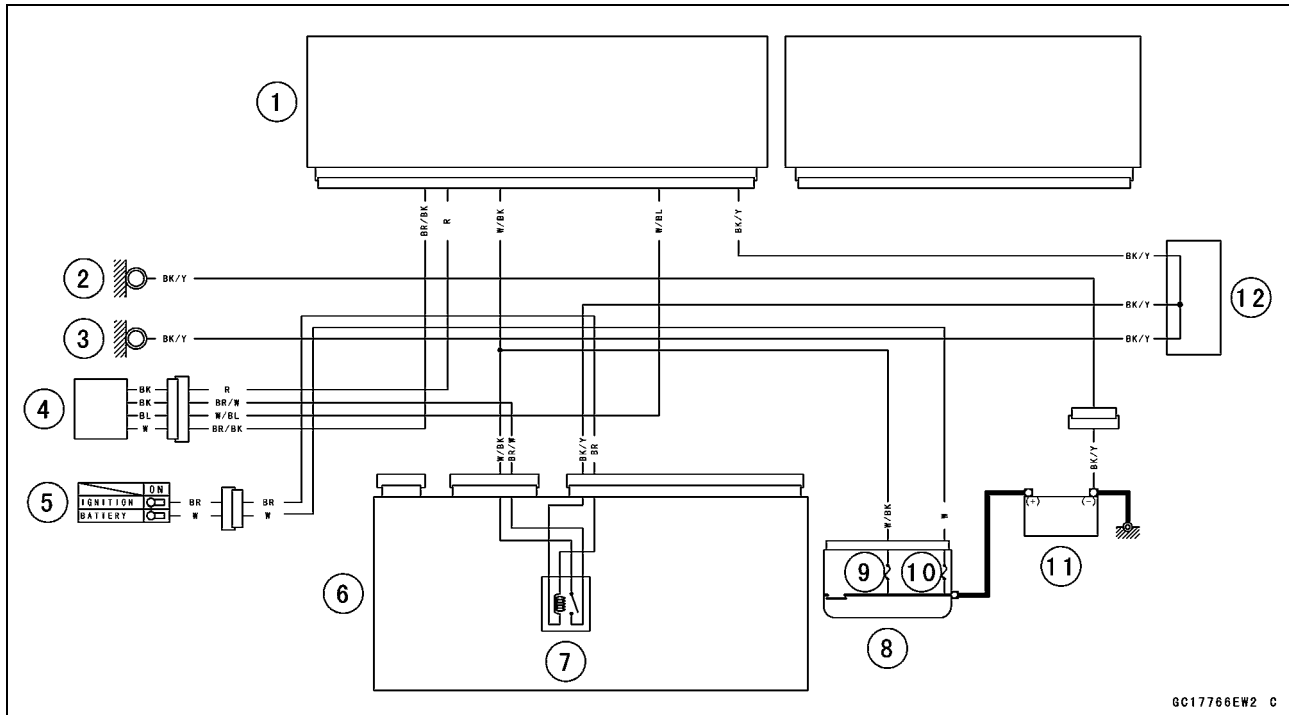

6C17766EW2 C

- | | |
|--------------------|-------------------------|
| 1. ECU | 7. ECU Main Relay |
| 2. Meter Ground | 8. Starter Relay |
| 3. Frame Ground | 9. FI Fuse 15 A |
| 4. Oxygen Sensor | 10. Main Fuse 30 A |
| 5. Ignition Switch | 11. Battery 12 V 8 Ah |
| 6. Relay Box | 12. Water-proof Joint C |

Warning Indicator Light (LED)

Light (LED) Inspection

- The warning indicator light (LED) [A] is used for the FI indicator, immobilizer indicator (immobilizer models) and oil pressure warning indicator.
- In this model, the warning indicator light (LED) (FI/immobilizer) blink by the data sent from the ECU.
- Refer to the Meter Unit Inspection in the Electrical System chapter for the warning indicator light (LED) (FI/immobilizer) inspection.

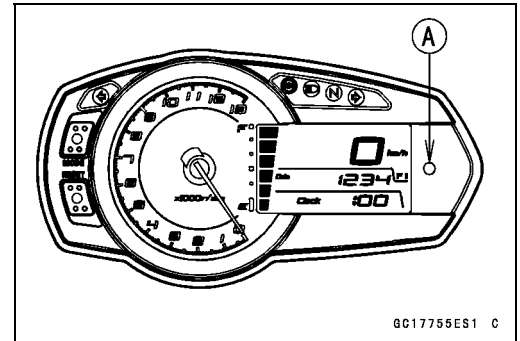

Warning Indicator Light (LED) (FI/Immobilizer) Circuit

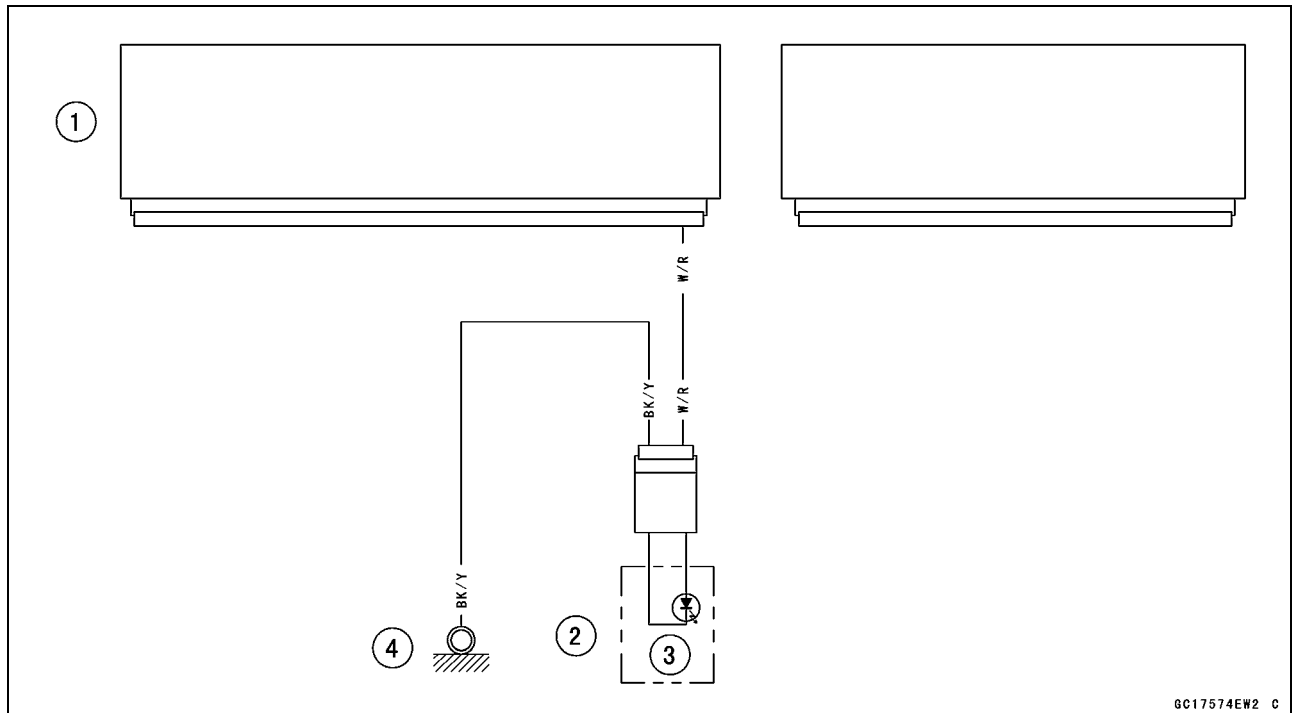

1. ECU
2. Meter Unit
3. Warning Indicator Light (LED)
4. Meter Ground

3-106 FUEL SYSTEM (DFI)

ECU

ECU Identification

○Most countries have their own regulations, so each ECU has different characteristic. So, do not confuse ECU with each other and use only the ECU for your model. Otherwise, the motorcycle cannot clear the regulation.

ECU Identification

Part Number [A]	Specification
21175-0333	WVTA (Full H), with immobilizer GB WVTA (Full H), with immobilizer Australia, with immobilizer
21175-0334	US (except California), without immobilizer US (California), without immobilizer Canada, without immobilizer
21175-0704	WVTA (78.2H), with immobilizer
21175-0335	Southeast Asia, with immobilizer

Full: Full Power

H: Honeycomb Type Catalyst

78.2: Maximum Horsepower 78.2 kW (106.3 PS)

ECU Removal

NOTICE

Never drop the ECU especially on a hard surface. Such a shock to the ECU can damage it.

NOTE

○Refer to the Immobilizer System Parts Replacement in the Electrical System chapter for the immobilizer models (see Immobilizer System Parts Replacement in the Electrical System chapter).

- Remove:
 - Relay Box (see Relay Box Removal in the Electrical System chapter)
 - ECU Connectors [A]
 - ECU [B]

ECU Installation

- Connect the ECU connectors [A].
- Install the ECU [B] into the rubber protector [C].
- Insert the slits of the rubber protector to the projections [D] of the bracket.

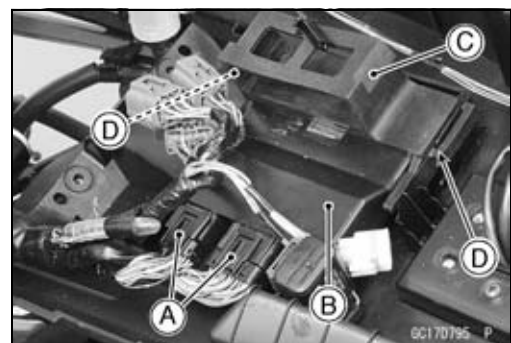
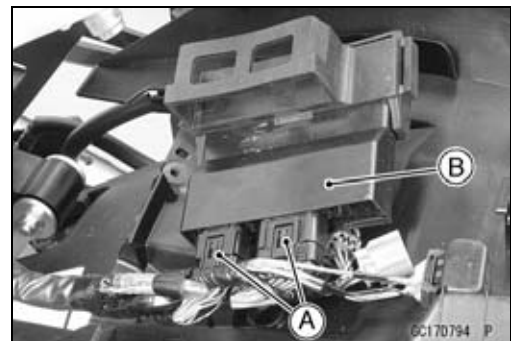
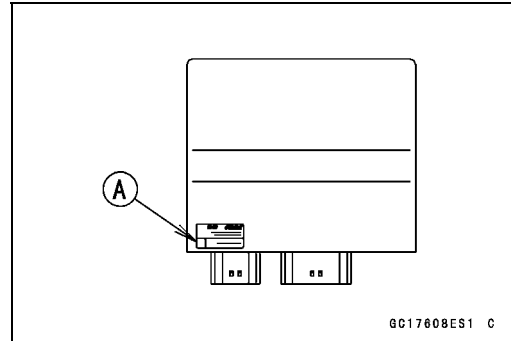

ECU

ECU Power Supply Inspection

- Visually inspect the ECU connectors.
- ★ If the connector is clogged with mud or dust, blow it off with compressed air.
- Remove the ECU (see ECU Removal).
- Visually inspect the terminals [A] of the ECU connectors.
- ★ If the terminals of the main harness connectors are damaged, replace the main harness.
- ★ If the terminals of the ECU connectors are damaged, replace the ECU.

- Turn the ignition switch OFF.
- Disconnect the ECU connectors [A].
- Set the hand tester [B] to the $\times 1 \Omega$ range and check the following wiring for continuity.

Special Tool - Hand Tester: 57001-1394

ECU Grounding Inspection

Connections:

(I) BK/Y leads (ECU terminal 30, 53 or 54) \longleftrightarrow Battery (-) Terminal

(II) Engine Ground \longleftrightarrow Battery (-) Terminal

Criteria:

Both: 0 Ω

- ★ If no continuity, check the connectors, the engine ground lead, or main harness, and repair or replace them if necessary.

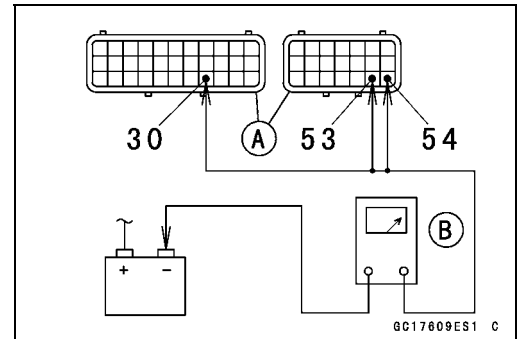
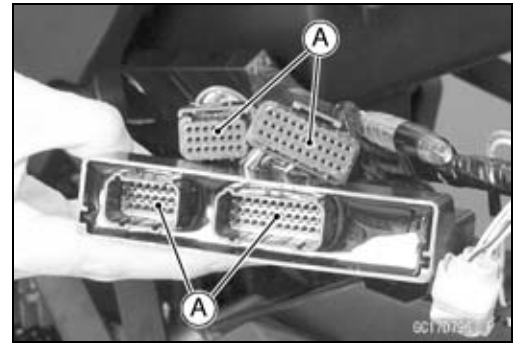

3-108 FUEL SYSTEM (DFI)

ECU

★ If the wiring is good, check the power source voltage of the ECU.

NOTE

○ Be sure the battery is fully charged.

- Connect the ECU and relay box connectors.
- Connect a digital meter [A] to the connectors [B] with the needle adapter set.

Special Tool - Needle Adapter Set: 57001-1457

ECU Power Supply Inspection

Connections:

- (I) Digital Meter (+) → Terminal 6 (BR/W)
Digital Meter (-) → Battery (-) terminal
- (II) Digital Meter (+) → Terminal 8 (W/BK)
Digital Meter (-) → Battery (-) terminal

Ignition Switch OFF:

Terminal 6 (BR/W): 0 V

Terminal 8 (W/BK): Battery Voltage

Ignition Switch ON:

Both: Battery Voltage

★ If the reading is out of the specification, check the following.

Main Fuse 30 A (see Fuse Inspection in the Electrical System chapter)

FI Fuse 15 A (see Fuse Inspection Electrical System chapter)

ECU Main Relay (see Relay Circuit Inspection in the Electrical System chapter)

Power Source Wiring (see wiring diagram in this section)

★ If the fuse, wiring and relay are good, replace the ECU (see ECU Removal/Installation).

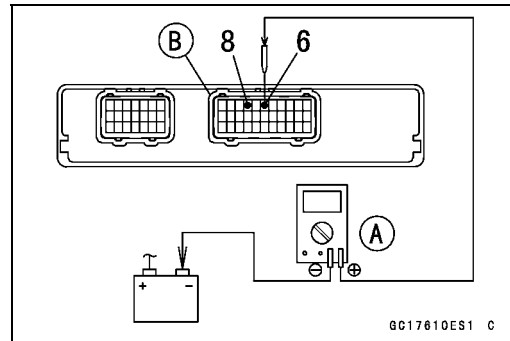

ECU

ECU Power Source Circuit

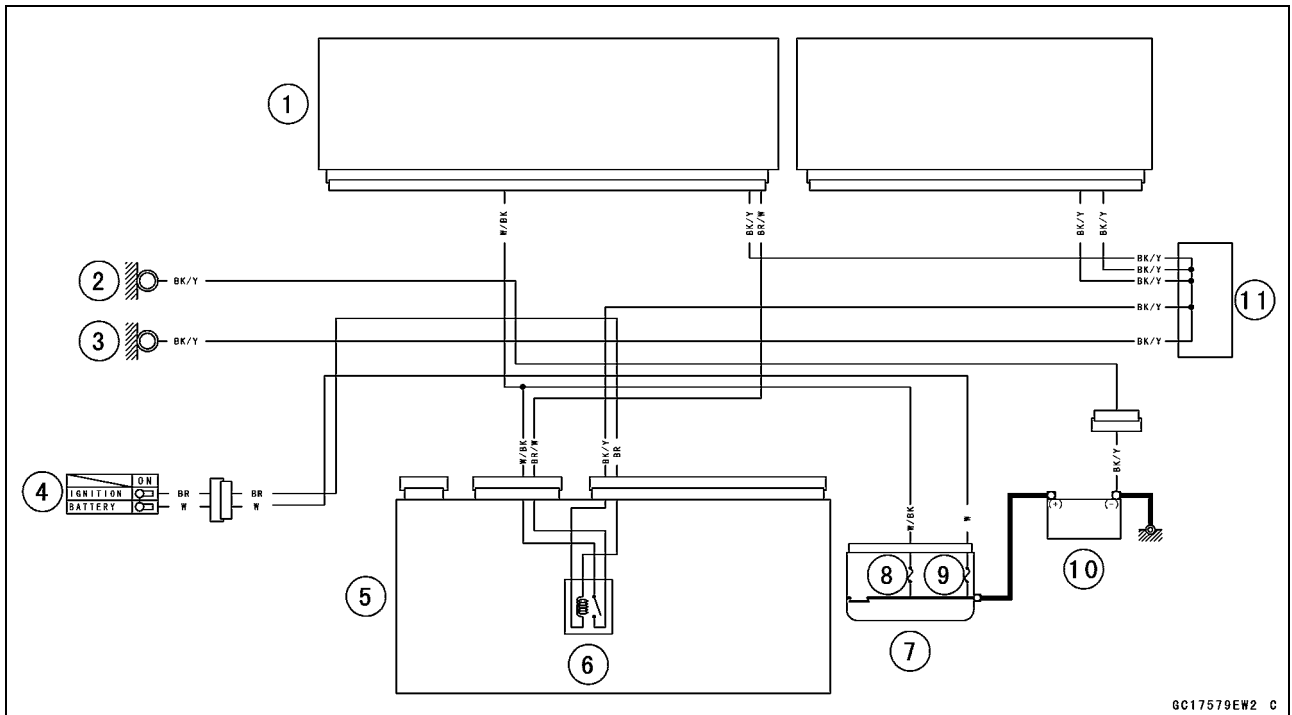

GC17579EW2 C

1. ECU
2. Meter Ground
3. Frame Ground
4. Ignition Switch
5. Relay Box
6. ECU Main Relay
7. Starter Relay
8. FI Fuse 15 A
9. Main Fuse 30 A
10. Battery 12 V 8 Ah
11. Water-proof Joint C

3-110 FUEL SYSTEM (DFI)

DFI Power Source

ECU Fuse Removal

- Refer to the 15 A FI Fuse Removal in the Electrical System chapter.

ECU Fuse Installation

- ★ If a fuse fails during operation, inspect the DFI system to determine the cause, and then replace it with a new fuse of proper amperage.
- Refer to the Fuse Installation in the Electrical System chapter.

ECU Fuse Inspection

- Refer to the Fuse Inspection in the Electrical System chapter.

ECU Main Relay Removal/Installation

○ The ECU main relay is built in the relay box [A].

- Refer to the Relay Box Removal in the Electrical System chapter.



ECU Main Relay Inspection

- Refer to the Relay Circuit Inspection in the Electrical System chapter.

Fuel Line

Fuel Pressure Inspection

NOTE

○Be sure the battery is fully charged.

- Remove:
 - Fuel Hose (see Fuel Hose Replacement in the Periodic Maintenance chapter)
- Support the fuel tank with a suitable bar (see Fuel Tank Removal in the Fuel System (DFI) chapter).
- Be sure to place a piece of cloth around the fuel outlet pipe of the fuel pump and the delivery pipe of the throttle body assy.

⚠ WARNING

Fuel is flammable and explosive under certain conditions and can cause severe burns. Be prepared for fuel spillage; any spilled fuel must be completely wiped up immediately. When the fuel hose is disconnected, fuel spills out from the hose and the pipe because of residual pressure. Cover the hose connection with a piece of clean cloth to prevent fuel spillage.

- Install the fuel pressure gauge adapter [A] and fuel hoses (Special Tool: 57001-1607) [B] between the fuel outlet pipe and delivery pipe.
- Secure the fuel hoses with the clamps.
- Connect the pressure gauge [C] to the fuel pressure gauge adapter.

Special Tools - Oil Pressure Gauge, 5 kgf/cm²: 57001-125
Fuel Pressure Gauge Adapter: 57001-1593
Fuel Hose: 57001-1607

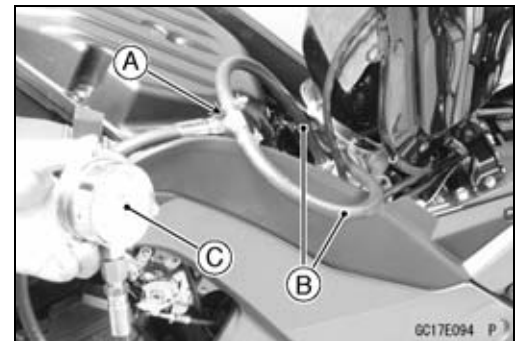

⚠ WARNING

Fuel is extremely flammable and can be explosive under certain conditions resulting in serious injury or death. Do not try to start the engine with the fuel hoses disconnected.

- Connect the fuel pump lead connector.
- Turn the engine stop switch run position.
- Turn the ignition switch ON.
- The fuel pump should operate for 3 seconds, and then should stop.

NOTE

○After turning on the engine stop switch and ignition switch, inspect the fuel leakage from the connected portion of the special tools.

NOTICE

Do not drive the fuel pump 3 seconds or more without the fuel in the fuel tank. If the fuel pump is driven without the fuel, it may be damaged.

3-112 FUEL SYSTEM (DFI)

Fuel Line

- Start the engine, and let it idle.
- Measure the fuel pressure with the engine idling.

Fuel Pressure (with Engine Idling)

Standard: 294 kPa (3.0 kgf/cm², 43 psi)

NOTE

○ *The gauge needle will fluctuate. Read the pressure at the average of the maximum and minimum indications.*

- Turn the ignition switch OFF.
- ★ If the fuel pressure is much higher than specified, replace the fuel pump because the fuel pressure regulator in the fuel pump have been clogged or stuck.
- ★ If the fuel pressure is much lower than specified, check the following.
 - Fuel Line Leakage (see Fuel Injector Fuel Line Inspection)
 - Amount of Fuel Flow (see Fuel Flow Rate Inspection)
- After above checks, measure the fuel pressure again.
- Remove the fuel pressure gauge, hoses and adapter.
- Install:
 - Fuel Hose (see Fuel Hose Replacement in the Periodic Maintenance chapter)
 - Fuel Tank (see Fuel Tank Installation)
- Confirm that the drain hose and clamp are installed securely and run the hose correctly (see Cable, Wire, and Hose Routing section in the Appendix chapter).
- Start the engine and check for fuel leakage.

Fuel Flow Rate Inspection

WARNING

Gasoline is extremely flammable and can be explosive under certain conditions, creating the potential for serious burns. Make sure the area is well-ventilated and free from any source of flame or sparks; this includes any appliance with a pilot light. Do not smoke. Turn the ignition switch OFF. Be prepared for fuel spillage; any spilled fuel must be completely wiped up immediately.

NOTE

○ *Be sure the battery is fully charged.*

- Turn the ignition switch OFF.
- Wait until the engine cools down.
- Prepare a fuel hose (Special Tool: 57001-1607) and a measuring cylinder.
 - Special Tool - Fuel Hose: 57001-1607**
- Support the fuel tank with a suitable bar (see Fuel Tank Removal in the Fuel System (DFI) chapter).

Fuel Line

- Open the fuel tank cap [A] to lower the pressure in the tank.
- Remove the fuel hose from the fuel pump (see Fuel Tank Removal).
- Be sure to place a piece of cloth around the fuel outlet pipe of the fuel pump.

⚠ WARNING

Fuel is flammable and explosive under certain conditions and can cause severe burns. Be prepared for fuel spillage; any spilled fuel must be completely wiped up immediately. When the fuel hose is disconnected, fuel spills out from the hose and the pipe because of residual pressure. Cover the hose connection with a piece of clean cloth to prevent fuel spillage.

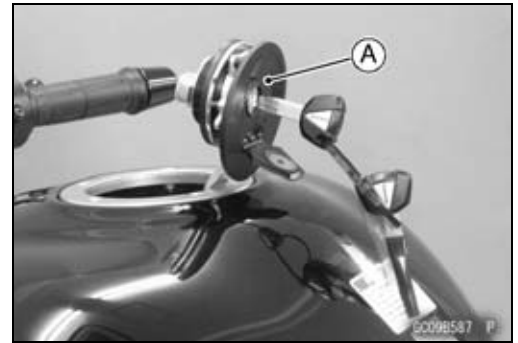

- Connect the prepared fuel hose [A] to the fuel outlet pipe.
- Secure the fuel hose with a clamp.
- Insert the fuel hose into the measuring cylinder [B].

⚠ WARNING

Wipe off spilled out fuel immediately. Be sure to hold the measuring cylinder vertical.

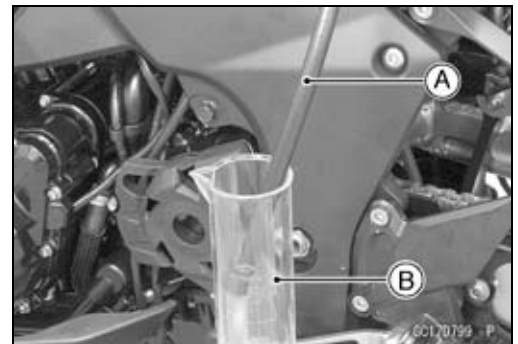

- Close the fuel tank cap.
- Turn the engine stop switch to run position.
- Turn the ignition switch ON.
- The fuel pump should operate for 3 seconds, and then should stop.

NOTICE

Do not drive the fuel pump 3 seconds or more without the fuel in the fuel tank. If the fuel pump is driven without the fuel, it may be damaged.

- Measure the discharge for 3 seconds.
- Repeat this operation several times.

Amount of Fuel Flow

Standard: 50 mL (1.7 US oz.) or more for 3 seconds

- Turn the ignition switch OFF.
- ★ If the fuel flow is much less than the specified, replace the fuel pump (see Fuel Pump Removal/Installation).
- Install the fuel tank (see Fuel Tank Installation).
- Confirm that the drain hose and clamp are installed securely and run the hose correctly (see Cable, Wire, and Hose Routing section in the Appendix chapter).
- Start the engine and check for fuel leakage.

3-114 FUEL SYSTEM (DFI)

Fuel Pump

Fuel Pump Removal

⚠ WARNING

Gasoline is extremely flammable and can be explosive under certain conditions, creating the potential for serious burns. Make sure the area is well-ventilated and free from any source of flame or sparks; this includes any appliance with a pilot light. Do not smoke. Turn the ignition switch OFF. Disconnect the battery (–) terminal. To avoid fuel spills, draw it from the tank when the engine is cold. Be prepared for fuel spillage; any spilled fuel must be completely wiped up immediately.

NOTICE

Never drop the fuel pump especially on a hard surface. Such a shock to the pump can damage it.

- Draw the fuel out from the fuel tank with a commercially available electric pump.
- Remove the fuel tank (see Fuel Tank Removal).
- Be careful of fuel spillage from the fuel tank since fuel still remains in the fuel tank and fuel pump. Plug the fuel pipe of the fuel tank.
- Turn the fuel tank upside down.
- Remove the fuel pump bolts [A], and take out the fuel pump [B].

NOTICE

Do not pull the leads of the fuel pump. If they are pulled, the lead terminals may be damaged.

- Discard the fuel pump gasket [A].

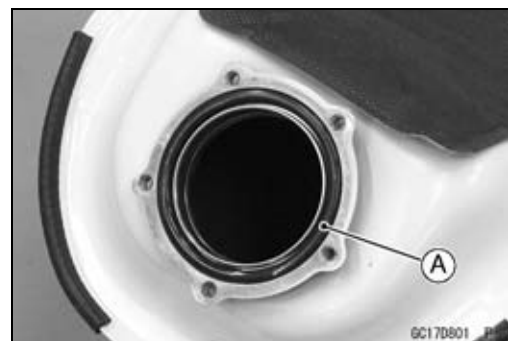
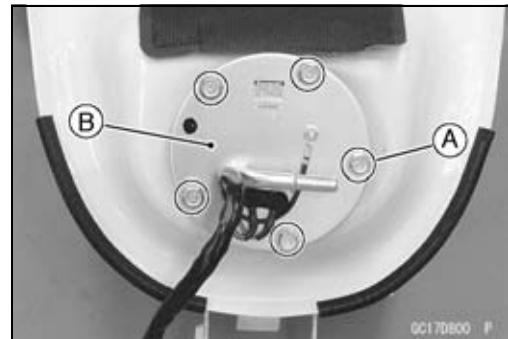

Fuel Pump

Fuel Pump Installation

- Remove dirt or dust from the fuel pump [A] by lightly applying compressed air.
- Replace the fuel pump gasket with a new one.

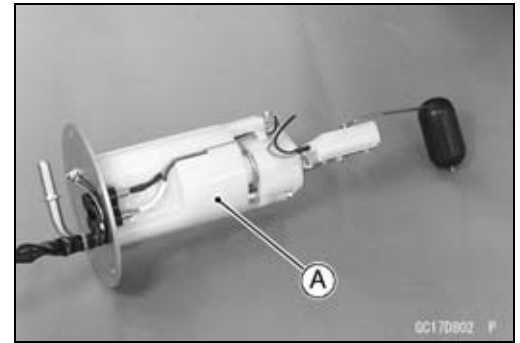

- Check that the fuel pump terminal [A] and band [B] are in place.
 - Apply a non-permanent locking agent to the threads of the fuel pump bolts.
 - Tighten the fuel pump bolts [C] to a snug fit.
 - Tighten the fuel pump bolts alternating diagonally.
- Torque - Fuel Pump Bolts: 9.8 N·m (1.0 kgf·m, 87 in·lb)**
- Tighten the pump bolts again to check the tightness.

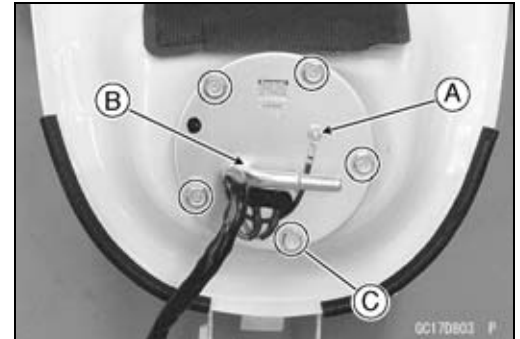

Fuel Pump Operation Inspection

NOTE

○ Be sure the battery is fully charged.

- Turn the engine stop switch to run position.
 - Turn the ignition switch ON and make sure that the fuel pump operates (make light sounds) for 3 seconds, and then stops.
 - Turn the ignition switch OFF.
- ★ If the pump does not operate as described above, check the operating voltage (see Fuel Pump Operating Voltage Inspection).

3-116 FUEL SYSTEM (DFI)

Fuel Pump

Fuel Pump Operating Voltage Inspection

NOTE

○Be sure the battery is fully charged.

- Turn the ignition switch OFF.
- Remove the front seat (see Front Seat Removal in the Frame chapter).
- Disconnect the fuel pump lead connector and connect the harness adapter [A] between these connectors as shown.
Main Harness [B]
Fuel Pump [C]

Special Tool - Measuring Adapter: 57001-1700

- Connect a digital meter [D] to the harness adapter leads.

Fuel Pump Operating Voltage

Connections to Adapter:

Digital Meter (+) → R (pump BK/Y) lead

Digital Meter (-) → BK (pump BK/W) lead

- Measure the operating voltage with engine stopped and with the connector joined.
- Turn the engine stop switch run position.
- Turn the ignition switch ON.

Operating Voltage

Standard: Battery Voltage for 3 seconds, and then 0 V

- Turn the ignition switch OFF.
- ★ If the reading is not the standard, check the ECU main relay and fuel pump relay (see Relay Circuit Inspection in the Electrical System chapter).
- ★ If the main relay and pump relay are normal, check the wiring for continuity (see Fuel Pump Circuit).
- ★ If the wiring is good, check the ECU for its ground and power supply (see ECU Power Supply Inspection).
- ★ If the ground and power supply are good, replace the ECU (see ECU Removal/Installation).

Pressure Regulator Removal

- The pressure regulator [A] is built into the fuel pump [B] and can not be removed.

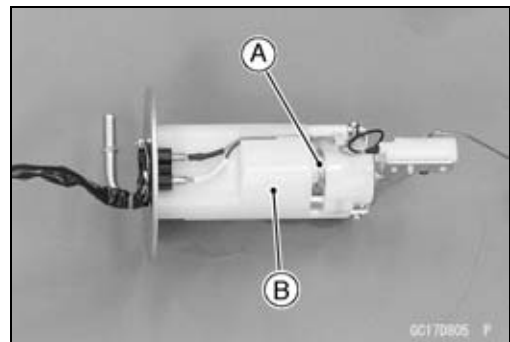
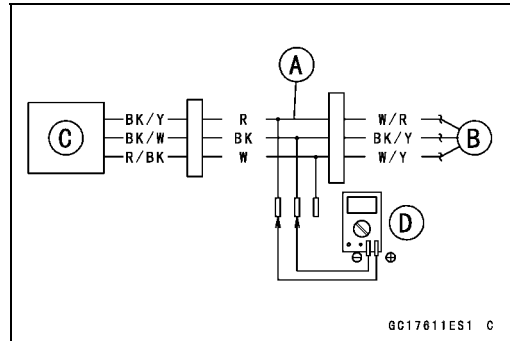
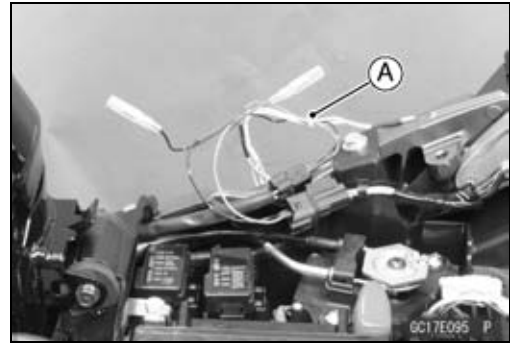

Fuel Pump

Pump Screen, Fuel Filter Cleaning

○The pump screen [A] and fuel filter [B] are built into the pump and can not be cleaned or checked.

★If the pump screen or fuel filter is suspected of clogging or being damaged, replace it with the fuel pump as a set.

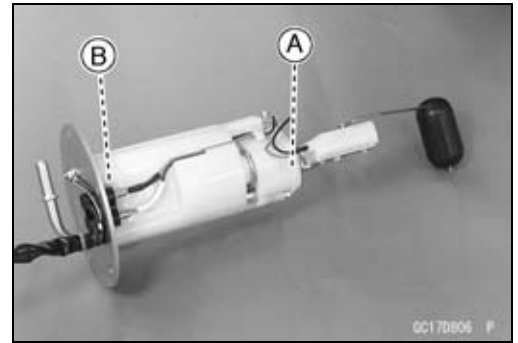

Fuel Pump Relay Removal/Installation

○The fuel pump relay is built in the relay box [A].

●Refer to the Relay Box Removal in the Electrical System chapter.



Fuel Pump Relay Inspection

●Refer to the Relay Circuit Inspection in the Electrical System chapter.

3-118 FUEL SYSTEM (DFI)

Fuel Pump

Fuel Pump Circuit

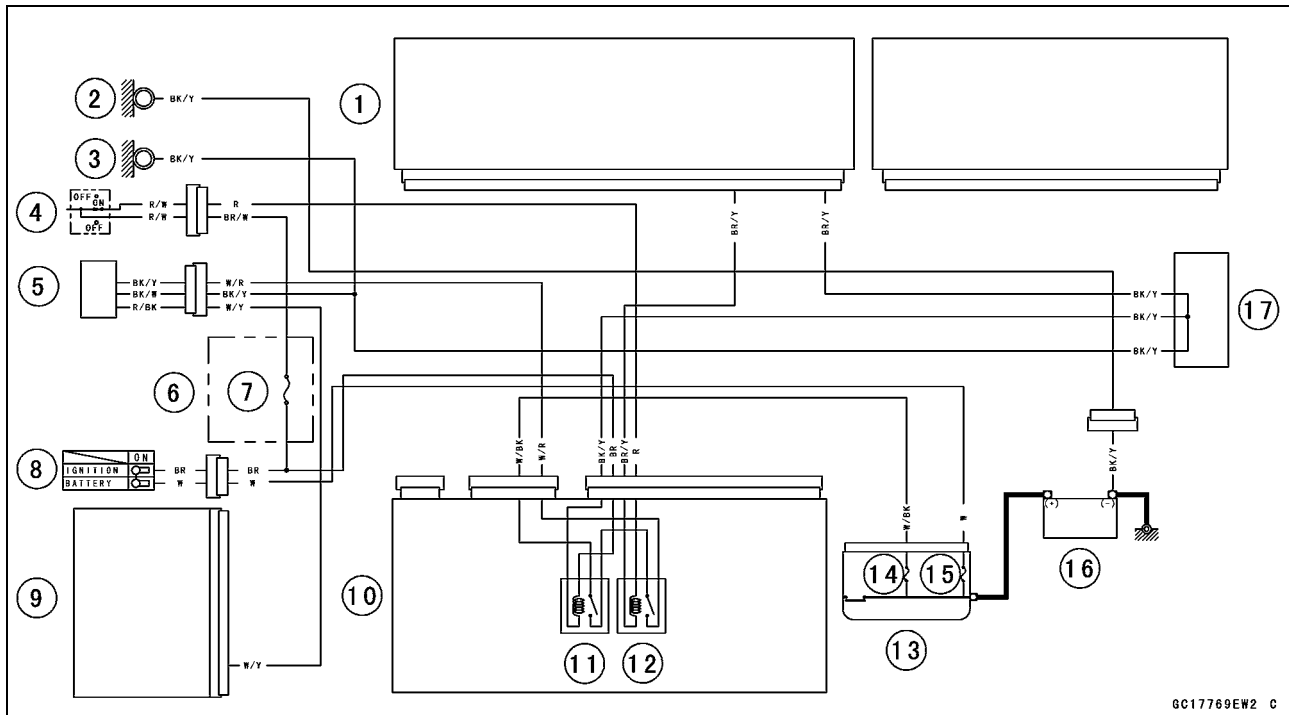

6C17769EW2 C

1. ECU
2. Meter Ground
3. Frame Ground
4. Engine Stop Switch
5. Fuel Pump/Fuel Level Sensor
6. Fuse Box 2
7. Ignition Fuse 15 A
8. Ignition Switch
9. Meter Unit
10. Relay Box
11. ECU Main Relay
12. Fuel Pump Relay
13. Starter Relay
14. FI Fuse 15 A
15. Main Fuse 30 A
16. Battery 12 V 8 Ah
17. Water-proof Joint C

Fuel Injectors

Fuel Injector Removal/Installation

- Refer to the Throttle Body Assy Disassembly/Assembly.

Fuel Injector Audible Inspection

NOTE

○ Be sure the battery is fully charged.

- Remove the lower side fairing (see Lower Side Fairing Removal in the Frame chapter).
- Start the engine, and let it idle.
- Apply the tip of a screwdriver [A] to the fuel injector [B]. Put the grip end onto your ear, and listen whether the fuel injector is clicking or not.
- A sound scope can also be used.
- The click interval becomes shorter as the engine speed rises.
- Do the same for the other fuel injectors.
- ★ If all the fuel injectors click at a regular intervals, the fuel injectors are normal.
- Turn the ignition switch OFF.
- ★ If any fuel injector does not click, check the fuel injector resistance (see Fuel Injector Resistance Inspection).

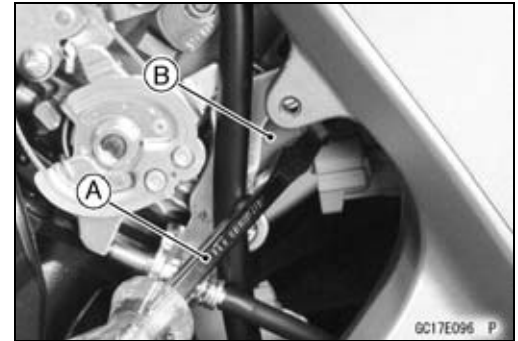

Fuel Injector Resistance Inspection

- Remove the throttle body assy with the connectors installed (see Throttle Body Assy Removal).
- Disconnect the injector connector.
- Connect a digital meter to the terminals [A] of the injector.
- Measure the fuel injector resistance.



Fuel Injector Resistance

Connections:

For Fuel Injector #1

W/R ↔ BL/R terminal

For Fuel Injector #2

W/R ↔ BL/O terminal

For Fuel Injector #3

W/R ↔ BL/W terminal

For Fuel Injector #4

W/R ↔ BL/Y terminal

Standard: About 11.7 ~ 12.3 Ω at 20°C (68°F)

- ★ If the reading is out of the standard, replace the injector.

3-120 FUEL SYSTEM (DFI)

Fuel Injectors

Fuel Injector Power Source Voltage Inspection

NOTE

○Be sure the battery is fully charged.

- Remove the air cleaner housing (see Air Cleaner Housing Removal).
- Turn the ignition switch OFF.
- Disconnect the injector connector and connect the harness adapter [A] between these connectors as shown.
Main Harness [B]
Fuel Injector #1 [C]

Special Tool - Measuring Adapter: 57001-1700

- Connect a digital meter [D] to the harness adapter lead.

Fuel Injector Power Source Voltage

Connections to Adapter:

For Fuel Injector #1, #2, #3, #4

Digital Meter (+) → R (injector W/R) lead

Digital Meter (-) → Battery (-) terminal

- Measure the power source voltage with the engine stopped.
- Turn the engine stop switch to run position.
- Turn the ignition switch ON.

Power Source Voltage

Standard: Battery Voltage for 3 seconds, and then 0 V

- Turn the ignition switch OFF.
- ★ If the reading is not the standard, check the ECU main relay and fuel pump relay (see Relay Circuit Inspection in the Electrical System chapter).
- ★ If the main relay and pump relay are normal, check the wiring (see Fuel Injector Circuit).
- ★ If the wiring is good, check the ECU for its ground and power supply (see ECU Power Supply Inspection).
- ★ If the ground and power supply are good, replace the ECU (see ECU Removal/Installation).

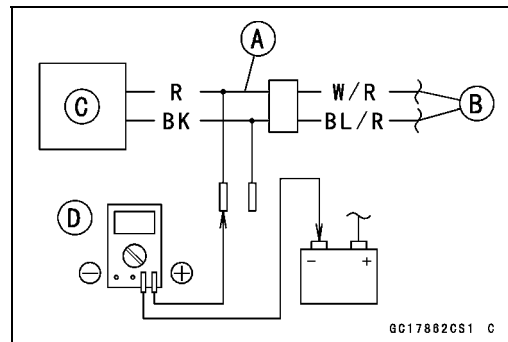

Fuel Injectors

Fuel Injector Output Voltage Inspection

NOTE

○ Be sure the battery is fully charged.

- Turn the ignition switch OFF.
- Remove the ECU (see ECU Removal).
- Do not disconnect the ECU connector.
- Connect the relay box connectors.
- Connect a digital meter [A] to the connectors [B] with the needle adapter set.

Special Tool - Needle Adapter Set: 57001-1457

Fuel Injector Output Voltage

Connections to ECU Connector:

For Fuel Injector #1

Digital Meter (+) → BL/R lead (ECU terminal 36)

Digital Meter (-) → Battery (-) terminal

For Fuel Injector #2

Digital Meter (+) → BL/O lead (ECU terminal 34)

Digital Meter (-) → Battery (-) terminal

For Fuel Injector #3

Digital Meter (+) → BL/W lead (ECU terminal 11)

Digital Meter (-) → Battery (-) terminal

For Fuel Injector #4

Digital Meter (+) → BL/Y lead (ECU terminal 10)

Digital Meter (-) → Battery (-) terminal

- Measure the output voltage with the engine stopped and with the connector joined.
- Turn the engine stop switch to run position.
- Turn the ignition switch ON.

Output Voltage

Standard: Battery Voltage for 3 seconds, and then 0 V

- Turn the ignition switch OFF.
- ★ If the reading is not the standard, check the ECU main relay and fuel pump relay (see Relay Circuit Inspection in the Electrical System chapter).
- ★ If the main relay and pump relay are normal, check the wiring (see Fuel Injector Circuit).
- ★ If the wiring is good, check the ECU for its ground and power supply (see ECU Power Supply Inspection).
- ★ If the ground and power supply are good, replace the ECU (see ECU Removal/Installation).
- ★ If there is still no battery voltage, check the fuel injector resistance (see Fuel Injector Resistance Inspection) and wiring (see Fuel Injector Circuit).

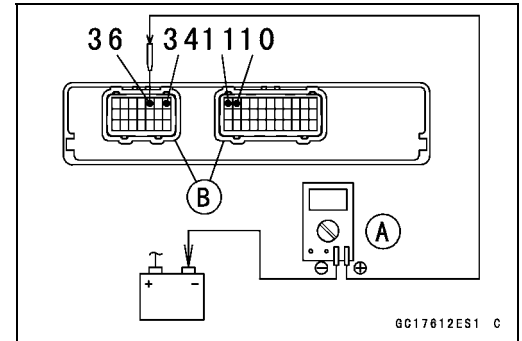

GC17612ES1 C

3-122 FUEL SYSTEM (DFI)

Fuel Injectors

Fuel Injector Fuel Line Inspection

- Remove:
 - Fuel Tank (see Fuel Tank Removal)
 - Fuel Hose (see Fuel Hose Replacement in the Periodic Maintenance chapter)
- Be sure to place a piece of cloth around the fuel outlet pipe of the fuel pump and the delivery pipe of the throttle body assy.

⚠ WARNING

Fuel is flammable and explosive under certain conditions and can cause severe burns. Be prepared for fuel spillage; any spilled fuel must be completely wiped up immediately. When the fuel hose is disconnected, fuel spills out from the hose and the pipe because of residual pressure. Cover the hose connection with a piece of clean cloth to prevent fuel spillage.

- Check the injector fuel line for leakage as follows.
 - Connect a commercially available vacuum/pressure pump [A] to the nipple of the delivery pipe [B] with the fuel hose [C] (both ends with the clamps [D]) as shown in the figure.
 - Lower Side View [E]
 - Apply soap and water solution to the areas [F] as shown in the figure.
 - Watching the pressure gauge, squeeze the pump lever [G], and build up the pressure until the pressure reaches the maximum pressure.

Injector Fuel Line Maximum Pressure
Standard: 300 kPa (3.06 kgf/cm², 43 psi)

NOTICE

During pressure testing, do not exceed the maximum pressure for which the system is designed.

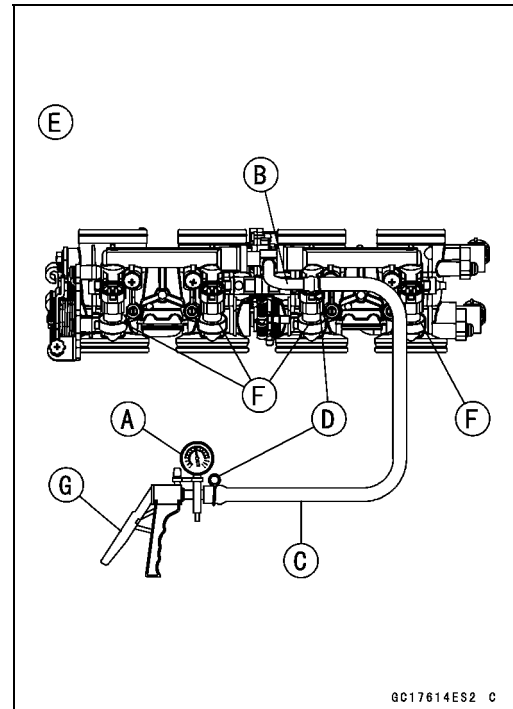

- Watch the gauge for at least 6 seconds.
- ★ If the pressure holds steady, the fuel line is good.
- ★ If the pressure drops at once or if bubbles are found in the area, the fuel line is leaking. Replace the delivery pipe assy, injectors and related parts.
- Repeat the leak test, and check the fuel line for no leakage.
- Install:
 - Fuel Hose (see Fuel Hose Replacement in the Periodic Maintenance chapter)
 - Fuel Tank (see Fuel Tank Installation)
- Confirm that the drain hose and clamp are installed securely and run the hose correctly (see Cable, Wire, and Hose Routing section in the Appendix chapter).
- Start the engine and check for fuel leakage.

Fuel Injectors

Fuel Injector Circuit

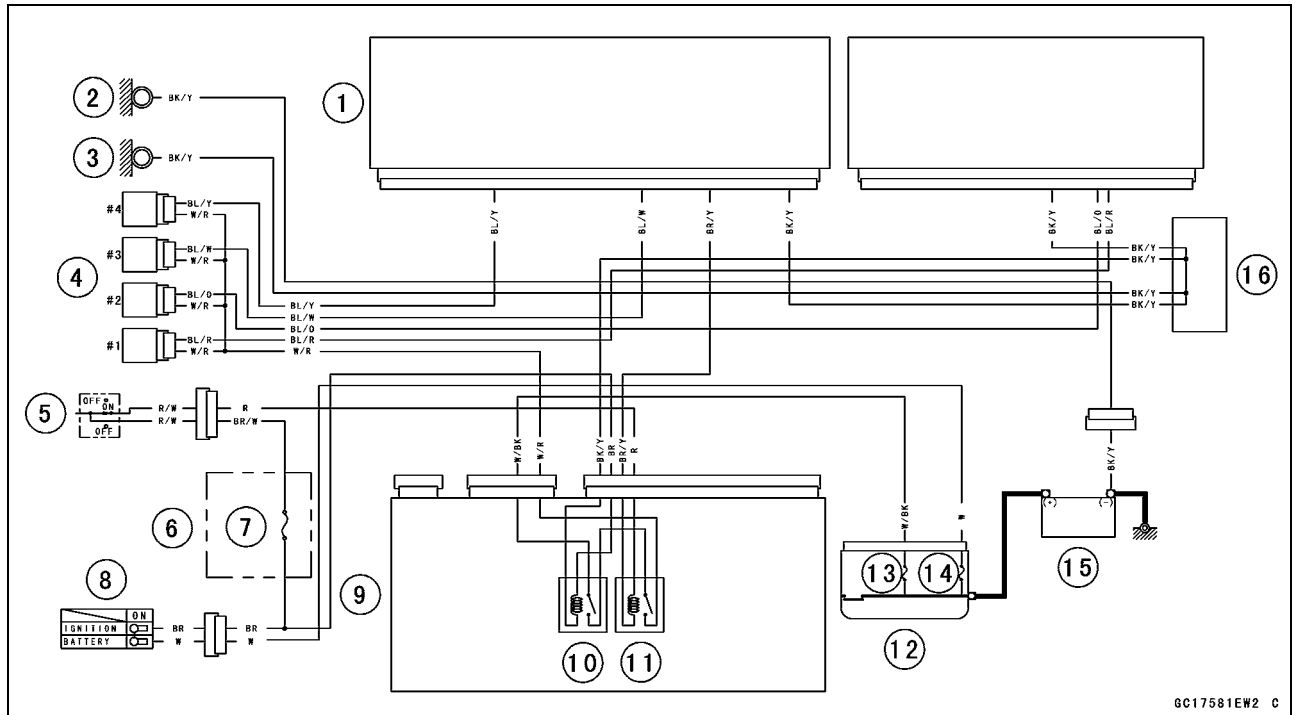

- | | |
|-----------------------|-------------------------|
| 1. ECU | 9. Relay Box |
| 2. Meter Ground | 10. ECU Main Relay |
| 3. Frame Ground | 11. Fuel Pump Relay |
| 4. Fuel Injectors | 12. Starter Relay |
| 5. Engine Stop Switch | 13. FI Fuse 15 A |
| 6. Fuse Box 2 | 14. Main Fuse 30 A |
| 7. Ignition Fuse 15 A | 15. Battery 12 V 8 Ah |
| 8. Ignition Switch | 16. Water-proof Joint C |

3-124 FUEL SYSTEM (DFI)

Throttle Grip and Cables

Free Play Inspection

- Refer to the Throttle Control System Inspection in the Periodic Maintenance chapter.

Free Play Adjustment

- Refer to the Throttle Control System Inspection in the Periodic Maintenance chapter.

Cable Installation

- Install the throttle cables in accordance with the Cable, Wire, and Hose Routing section in the Appendix chapter.
- Install the lower ends of the throttle cables in the throttle pulley on the throttle body assy after installing the upper ends of the throttle cables in the grip.
- After installation, adjust each cable properly (see Throttle Control System Inspection in the Periodic Maintenance chapter).

 WARNING
--

<p>Operation with incorrectly routed or improperly adjusted cables could result in an unsafe riding condition. Be sure the cables are routed correctly and properly adjusted.</p>
--

Cable Lubrication

- Refer to the Chassis Parts Lubrication in the Periodic Maintenance chapter.

Throttle Body Assy

Idle Speed Inspection/Adjustment

- Refer to the Idle Speed Inspection/Adjustment in the Periodic Maintenance chapter.

Synchronization Inspection/Adjustment

- Refer to the Engine Vacuum Synchronization Inspection in the Periodic Maintenance chapter.

Throttle Body Assy Removal

⚠ WARNING

Gasoline is extremely flammable and can be explosive under certain conditions, creating the potential for serious burns. Make sure the area is well-ventilated and free from any source of flame or sparks; this includes any appliance with a pilot light. Do not smoke. Turn the ignition switch OFF. Be prepared for fuel spillage; any spilled fuel must be completely wiped up immediately.

NOTICE

Never drop the throttle body assy, especially on a hard surface. Such a shock to the body assy can damage it.

- Remove:
 - Lower Fairing (see Lower Fairing Removal in the Frame chapter)
 - Air Cleaner Housing (see Air Cleaner Housing Removal)
 - Fuel Hose (see Fuel Hose Replacement in the Periodic Maintenance chapter)
- Disconnect:
 - Intake Air Pressure Sensor #1 Connector [A]
 - Intake Air Pressure Sensor #2 Connector [B]
 - Subthrottle Valve Actuator Connector [C]
- For California and Southeast Asia Models, pull off the vacuum hose [D].
- Disconnect:
 - Main Throttle Sensor Connector [A]
 - Subthrottle Sensor Connector [B]

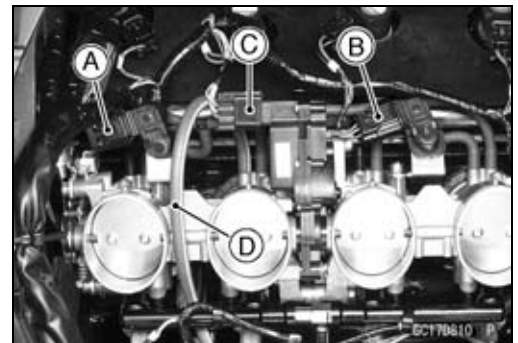

3-126 FUEL SYSTEM (DFI)

Throttle Body Assy

- Loosen the locknuts [A].
- Turn the adjusters [B] to give the more free play.

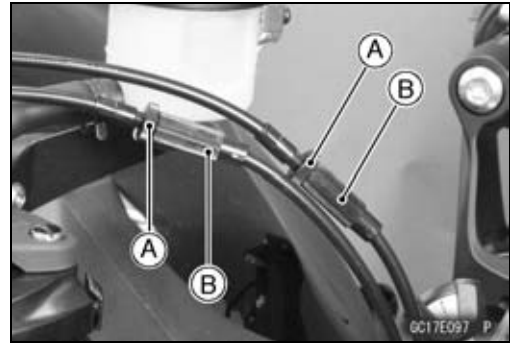

- Remove:
 - Lower Side Fairing (see Lower Side Fairing Removal in the Frame chapter)
 - Throttle Cable Holder Clamp [A]
 - Throttle Cable Lower Ends [B]

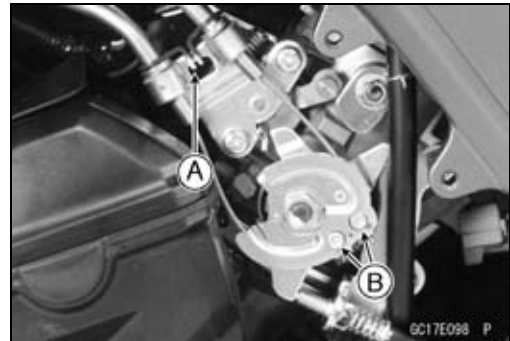

- Loosen the throttle body assy holder clamp bolts [A].
Special Tool - Carburetor Drain Plug Wrench, Hex 3: 57001-1269

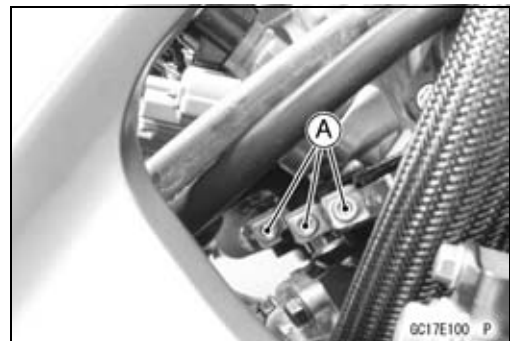
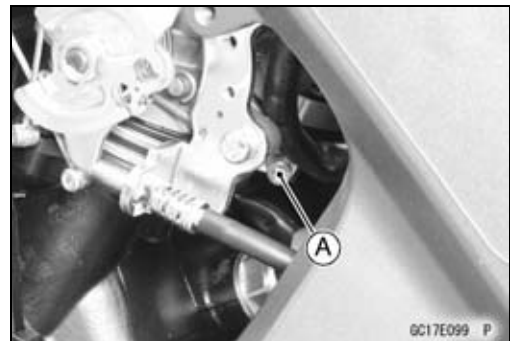

Throttle Body Assy

- Remove the throttle body assy [A] from the throttle body assy holders.
- Disconnect the injector connectors [B].
- Remove the clamps [C].
- After removing the throttle body assy, stuff pieces of lint-free, clean cloth into the throttle body assy holders.

⚠ WARNING

If dirt or dust is allowed to pass through into the throttle body assy, the throttle may become stuck, possibly causing accident.

NOTICE

If dirt gets into the engine, excessive engine wear and possible engine damage will occur.

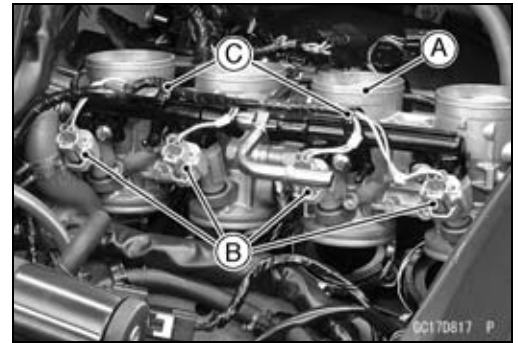

Throttle Body Assy Installation

- Be sure to position the throttle body assy holder clamp in original position (see Throttle Body Assy Holder Installation in the Engine Top End chapter).
- Connect the injector connectors [A].
- Install the throttle body assy to the throttle body assy holders.
- Install the clamps [B].
- Tighten:

Torque - Throttle Body Assy Holder Clamp Bolts: 2.9 N·m (0.30 kgf·m, 26 in·lb)

Special Tool - Carburetor Drain Plug Wrench, Hex 3: 57001-1269

- Apply a thin coat of grease to the throttle cable lower ends.
- Fit the accelerator cable end [A] and the decelerator cable end [B] into the throttle pulley.
- The accelerator cable has a clamp [C].
- Install the clamp securely.

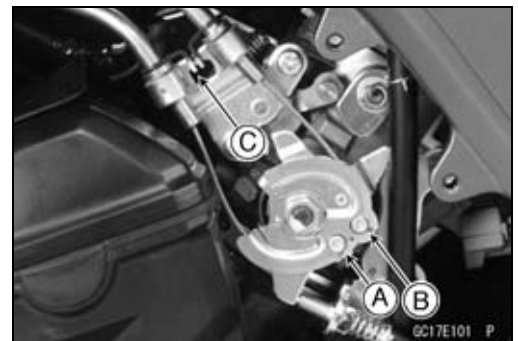
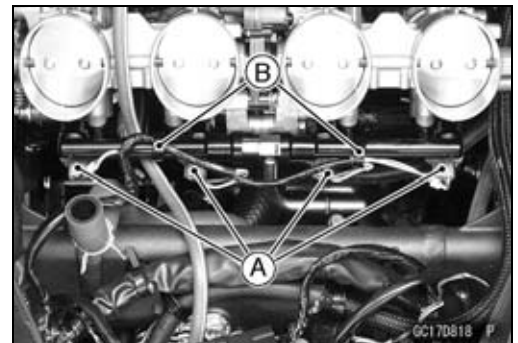

- Turn the throttle grip and make sure that the throttle pulley moves smoothly and return by spring force.
- Run the leads and hoses correctly (see Cable, Wire, and Hose Routing section in the Appendix chapter).
- Adjust:
 - Throttle Grip Free Play (see Throttle Control System Inspection in the Periodic Maintenance chapter)
 - Idle Speed (see Idle Speed Adjustment in the Periodic Maintenance chapter)

3-128 FUEL SYSTEM (DFI)

Throttle Body Assy

Throttle Body Assy Disassembly

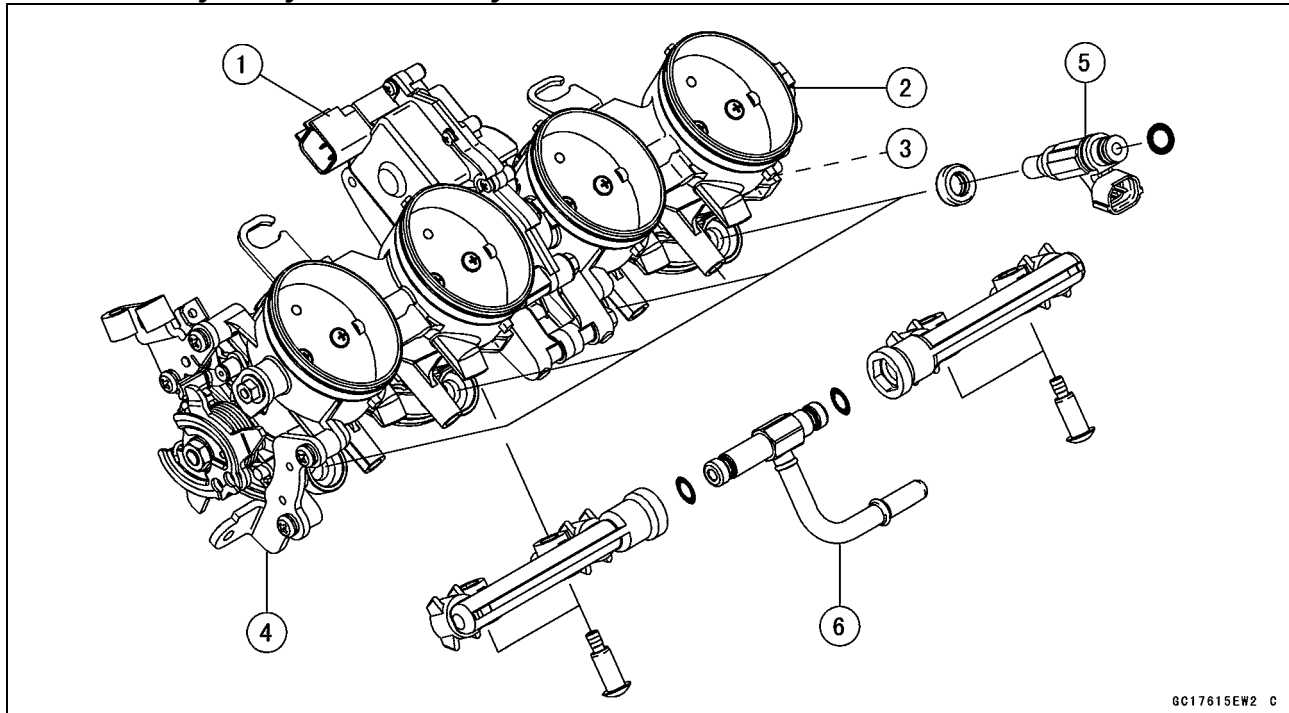

- 1. Subthrottle Valve Actuator
- 2. Subthrottle Sensor
- 3. Main Throttle Sensor
- 4. Throttle Body Assy
- 5. Fuel Injectors
- 6. Delivery Pipe Assy

NOTICE

Do not remove, disassemble or adjust the main throttle sensor, subthrottle sensor, subthrottle valve actuator, throttle link mechanism and throttle body assy, because they are adjust or set surely at the manufacturer. Adjustment of these parts could result in poor performance, requiring replacement of the throttle body assy.

- Remove the throttle body assy (see Throttle Body Assy Removal).
- Remove the delivery pipe assy mounting screws [A] to pull out the fuel injectors [B] from the throttle body assy together with the delivery pipe assy [C].

NOTE

- Do not damage the insertion portions of the injectors when they are pulled out from the throttle body.

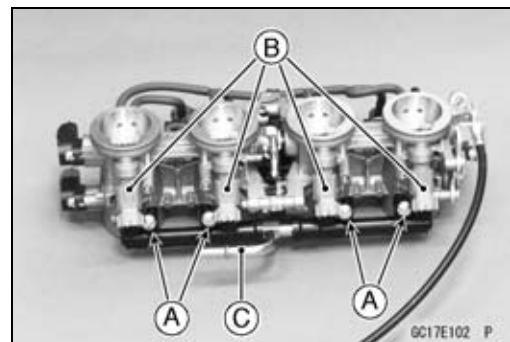

Throttle Body Assy

- Pull out the fuel injectors [A] from the delivery pipe assy [B].

NOTE

○ Do not damage the insertion portions of the injectors when they are pulled out from the delivery pipe assy.

NOTICE

Never drop the primary fuel injector, especially on a hard surface. Such a shock to the injector can damage it.

Throttle Body Assy Assembly

- Before assembling, blow away dirt or dust from the throttle body and delivery pipe assy by applying compressed air.
- Replace the O-rings [A] of each fuel injector [B] with new ones.
- Apply engine oil to the new O-rings, insert them to the delivery pipe assy [C] and confirm whether the injectors turn smoothly or not.

- Replace the dust seals [A] with new ones.
- Apply engine oil to the new dust seals.
- Install the fuel injectors along with the delivery pipe assy to the throttle body.
- Tighten:
 - Torque - Delivery Pipe Assy Mounting Screws: 3.4 N·m (0.35 kgf·m, 30 in·lb)**
- Install the throttle body assy (see Throttle Body Assy Installation).

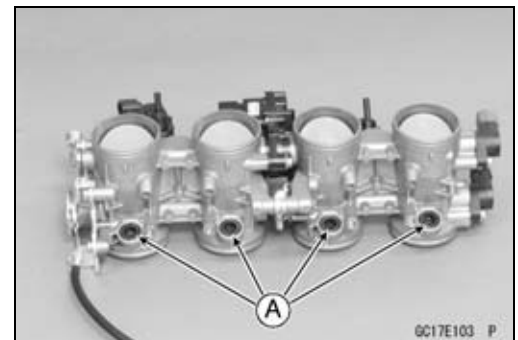
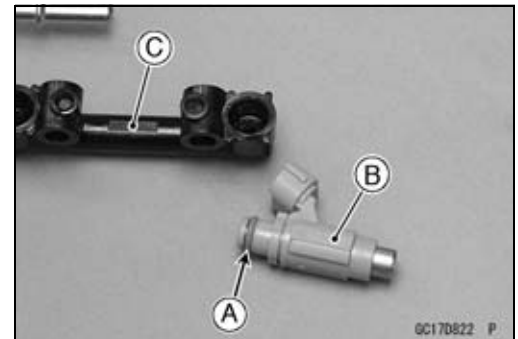
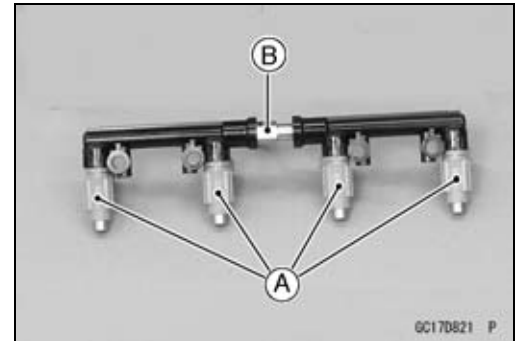

3-130 FUEL SYSTEM (DFI)

Air Cleaner

Air Cleaner Element Removal/Installation

- Refer to the Air Cleaner Element Replacement in the Periodic Maintenance chapter.

Air Cleaner Element Inspection

- Remove the air cleaner element (see Air Cleaner Element Replacement in the Periodic Maintenance chapter).
- Visually check the element [A] for tears or breaks.
- ★ If the element has any tears or breaks, replace the element.

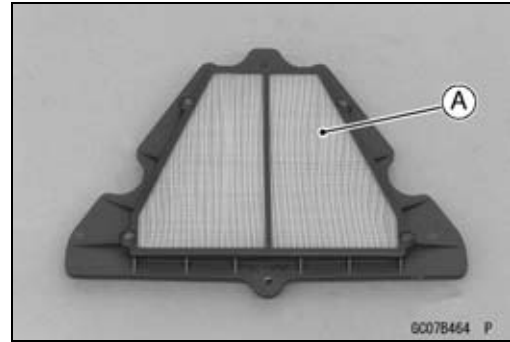

Air Cleaner Oil Draining

A drain hose is connected to the bottom of the air cleaner to drain water or oil accumulated in the cleaner part.

- Visually check the catch tank [A] of the drain hose, if the water or oil accumulates in the tank.
- ★ If any water or oil accumulates in the catch tank, remove the catch tank from the drain hose and drain it.

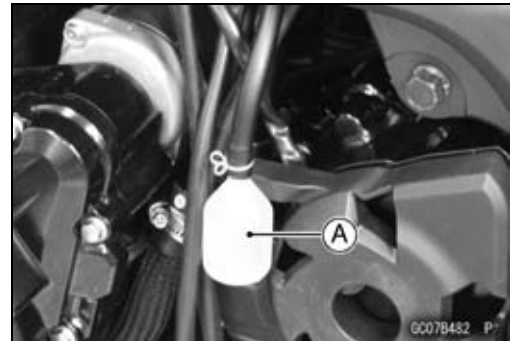

⚠ WARNING

Oil on tires will make them slippery and can cause an accident and injury. Be sure to reinstall the catch tank after draining.

Air Cleaner Housing Removal

- Remove:
 - Fuel Tank (see Fuel Tank Removal)
 - Connector Bracket [A]
 - Breather Hose [B]
 - Disconnect the intake air temperature sensor connector [C].
-
- Remove the bolt [A].

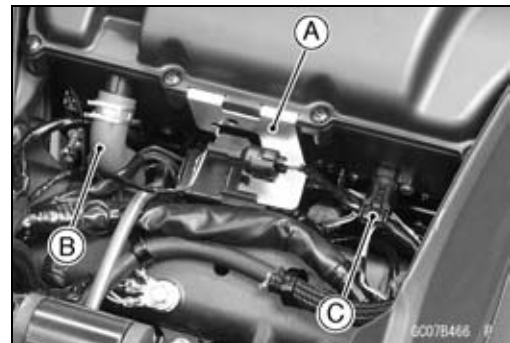

Air Cleaner

- Loosen the both air cleaner duct clamp bolts [A].

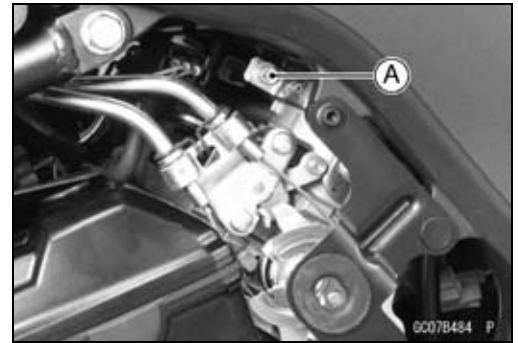

- Lift up the air cleaner housing, and remove the air switching valve hose [A].
- After removing the air cleaner housing, cover the clean cloth on the throttle body assy.

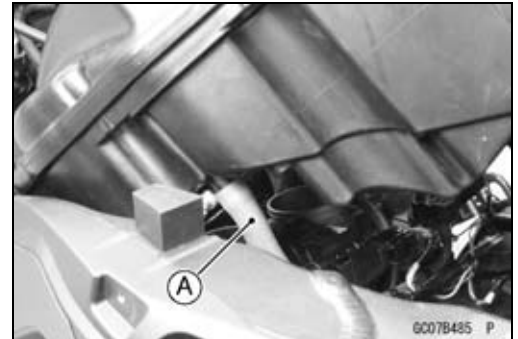

⚠ WARNING

If dirt or dust is allowed to pass through into the throttle body assy, the throttle may become stuck, possibly causing accident.

Air Cleaner Housing Installation

- Install the air switching valve hose [A] to the air cleaner housing.
- Install the air cleaner housing on the throttle body assy.
- Install the clamp bolt heads [B] outside as shown in the figure.
- Tighten:
 - Torque - Air Cleaner Duct Clamp Bolts: 2.0 N·m (0.20 kgf·m, 18 in·lb)**
- Tighten the air cleaner housing mounting bolts [C].
- Install the breather hose [D].
- Run the leads and hoses correctly (see Cable, Wire, and Hose Routing section in the Appendix chapter).
- Install the removed parts (see appropriate chapters).

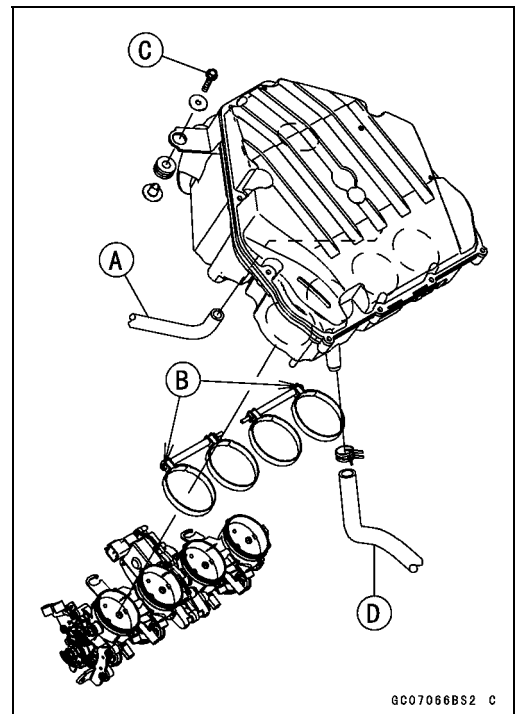

3-132 FUEL SYSTEM (DFI)

Fuel Tank

Fuel Tank Removal

⚠ WARNING

Gasoline is extremely flammable and can be explosive under certain conditions, creating the potential for serious burns. Make sure the area is well-ventilated and free from any source of flame or sparks; this includes any appliance with a pilot light. Do not smoke. Turn the ignition switch OFF. Disconnect the battery (-) terminal. To avoid fuel spills, draw it from the tank when the engine is cold. Be prepared for fuel spillage; any spilled fuel must be completely wiped up immediately.

- Turn the ignition switch OFF.
- Wait until the engine cools down.
- Disconnect the battery (-) terminal (see Battery Removal in the Electrical System chapter).
- Remove:
 - Lower Fairing (see Lower Fairing Removal in the Frame chapter)
 - Front Fuel Tank Bolts [A]



- Disconnect the fuel pump lead connector [A].

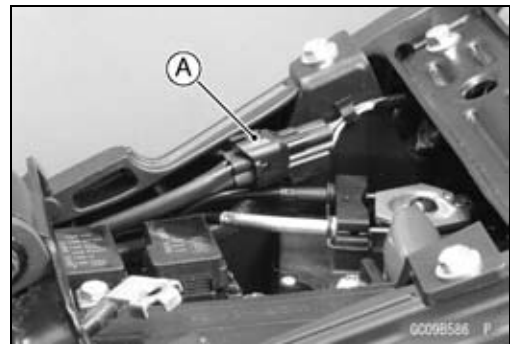

- Open the fuel tank cap [A] to lower the pressure in the tank.
- During tank removal, keep the tank cap open to release pressure in the tank. This makes fuel spillage less.

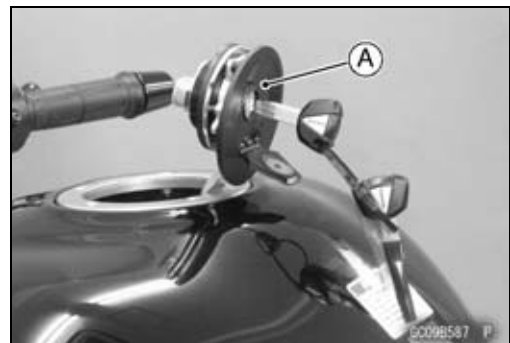

Fuel Tank

- Draw the fuel out from the fuel tank with a commercially available pump [A].
- Use a soft plastic hose [B] as a pump inlet hose in order to insert the hose smoothly.
- Put the hose through the fill opening [C] into the tank and draw the fuel out.

⚠ WARNING

Spilled fuel is flammable and can be explosive under certain conditions. The fuel can not be removed completely from the fuel tank. Be careful for remained fuel spillage.

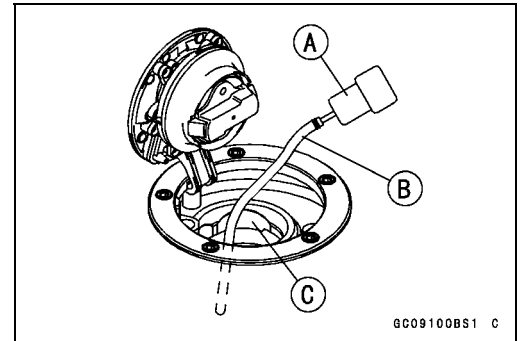

- Remove the both side cover (see Side Cover Removal in the Frame chapter).
- Lift up the fuel tank, and support it with a suitable bar [A].

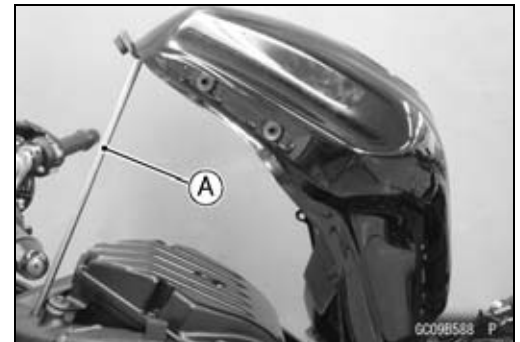

- Remove the drain hose [A] and clamp from the fuel tank.

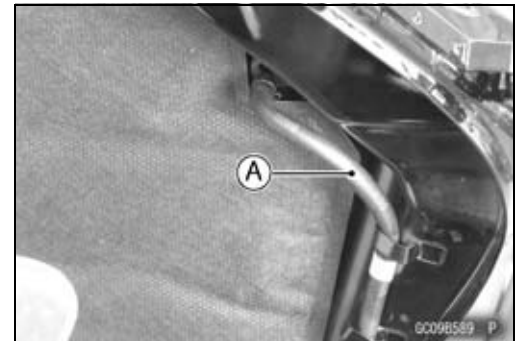

- Be sure to place a piece of cloth [A] around the fuel hose joint.
- Insert a thin blade screwdriver [B] into the slit [C] on the joint lock [D].
- Pry the screwdriver to disconnect the joint lock.

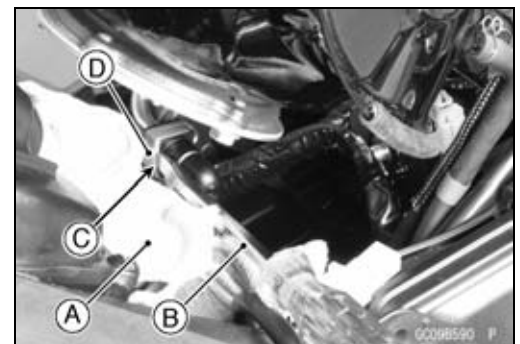

3-134 FUEL SYSTEM (DFI)

Fuel Tank

- Pull [A] the fuel hose joint [B] out of the outlet pipe.

⚠ WARNING

Fuel is flammable and explosive under certain conditions and can cause severe burns. Be prepared for fuel spillage; any spilled fuel must be completely wiped up immediately. When the fuel hose is disconnected, fuel spills out from the hose and the pipe because of residual pressure. Cover the hose connection with a piece of clean cloth to prevent fuel spillage.

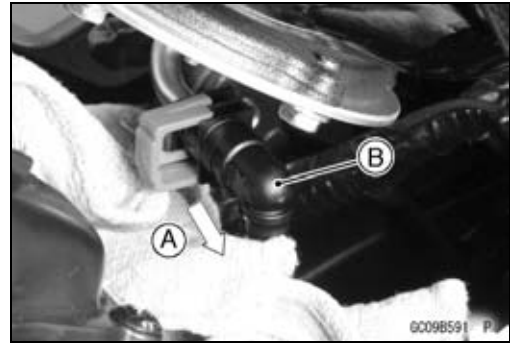

- Close the fuel tank cap.
- Remove the bar which supported fuel tank.
- For other than California and Southeast Asia models, remove the fuel tank breather hose [A] and rear fuel tank bolt [B].



- For the California and Southeast Asia models, remove the following.
 - Fuel Return Hose [A] (red)
 - Fuel Tank Breather Hose [B] (blue)
 - Rear Fuel Tank Bolt [C]

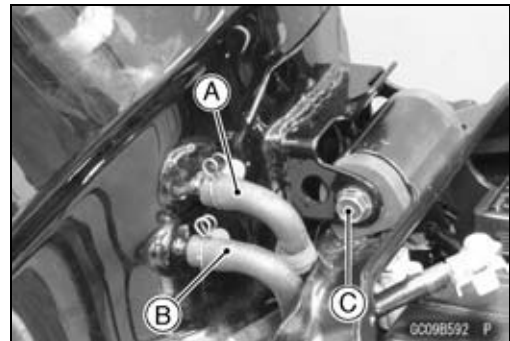

- Remove the fuel tank, and place it on a flat surface.
- Do not apply the load to the fuel pipe of the fuel pump.

Fuel Tank

- For the California and Southeast Asia models, note the following.

NOTICE

For the California and Southeast Asia models, if gasoline, solvent, water or any other liquid enters the canister, the canister's vapor absorbing capacity is greatly reduced. If the canister does become contaminated, replace it with a new one.

- Be sure to plug the evaporative fuel return hose to prevent fuel spilling before fuel tank removal.

⚠ WARNING

Spilled fuel is flammable and can be explosive under certain conditions. For California and Southeast Asia models, be careful not to spill fuel through the return hose.

- ★ If liquid or gasoline flows into the breather hose, remove the hose and blow it clean with compressed air.
- Be careful of fuel spillage from the fuel tank since fuel still remains in the fuel tank and fuel pump.

⚠ WARNING

Gasoline is extremely flammable and can be explosive under certain conditions, creating the potential for serious burns. Store the fuel tank in an area which is well-ventilated and free from any source of flame or sparks. Do not smoke in this area. Place the fuel tank on a flat surface and plug the fuel pipes to prevent fuel leakage.

Fuel Tank Installation

- Note the above WARNING (see Fuel Tank Removal).
- Check that the dampers [A], pad [B] and trims [C] are in place on the frame and the fuel tank.
- ★ If the dampers, pad or trims are damaged or deteriorated, replace them.
- Install the drain hose and clamp securely.
- Run the hoses correctly (see Cable, Wire, and Hose Routing section in the Appendix chapter).

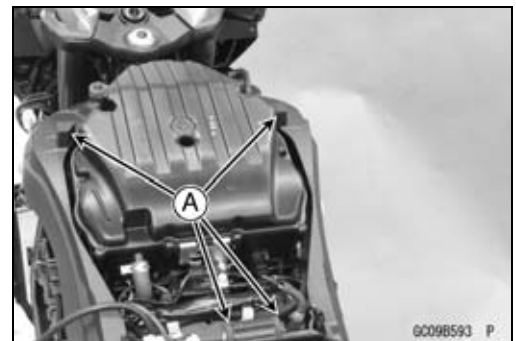

3-136 FUEL SYSTEM (DFI)

Fuel Tank

- For the California and Southeast Asia models, note the following.
 - To prevent the gasoline from flowing into or out of the canister, hold the separator perpendicular to the ground.
 - Connect the hoses according to the diagram of the evaporative emission control system. Make sure they do not get pinched or kinked.
 - Run hoses with a minimum of bending so that the air or vapor will not be obstructed.
- Insert the fuel hose joint [A] straight onto the fuel outlet pipe until the hose joint clicks.
- Push [B] the joint lock [C] until the hose joint clicks.

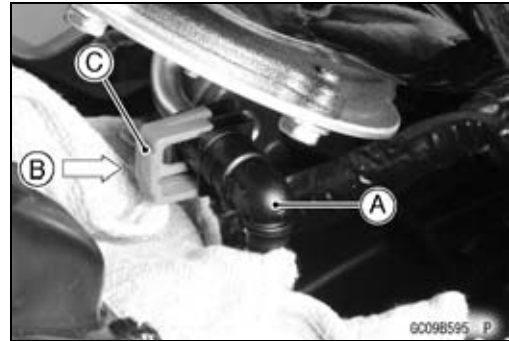

- Push and pull [A] the hose joint [B] back and forth more than two times, and make sure it is locked and does not come off.

⚠ WARNING

Make sure the hose joint is installed correctly on the delivery pipe or the fuel could leak.

- ★ If it comes off, reinstall the hose joint.
- Connect the fuel pump lead connector and the battery (-) terminal (see Battery Installation in the Electrical System chapter).
- Be careful not to pinch the leads, cables or harnesses around rear part of the fuel tank [A].

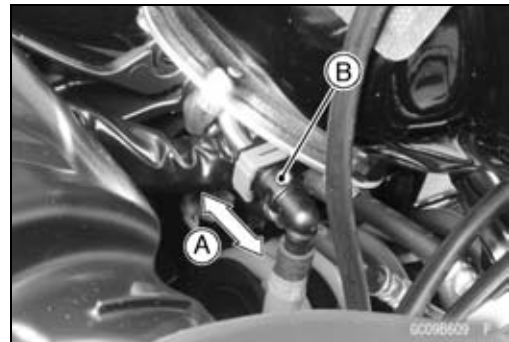

Fuel Tank

Fuel Tank and Cap Inspection

- Open the tank cap.
- Visually inspect the gasket [A] on the tank cap for any damage.
- ★ Replace the tank cap if gasket is damaged.
- Check to see if the water drain pipe [B] and fuel breather pipe [C] in the tank are not clogged. Check the tank cap breather also.
- ★ If they are clogged, remove the tank and drain it, and then blow the breather free with compressed air.

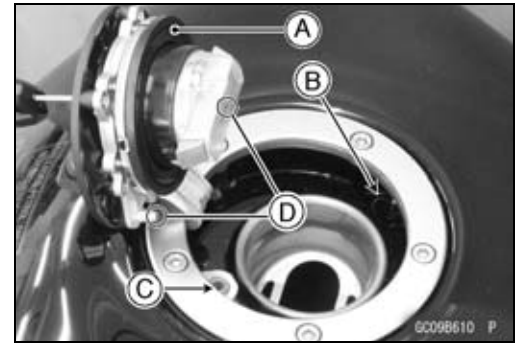

NOTICE

Do not apply compressed air to the air vent holes [D] in the tank cap. This could cause damage and clogging of the labyrinth in the cap.

Fuel Tank Cleaning

⚠ WARNING

Gasoline and low-flash point solvents can be flammable and/or explosive and cause severe burns. Clean the tank in a well-ventilated area, and take care that there are no sparks or flame anywhere near the working area. Do not use gasoline or low-flash point solvents to clean the tank.

- Remove:
 - Fuel Tank (see Fuel Tank Removal)
 - Fuel Pump (see Fuel Pump Removal)
- Pour some high-flash point solvent into the fuel tank and shake the tank to remove dirt and fuel deposits.
- Draw the solvent out of the fuel tank.
- Dry the tank with compressed air.
- Install:
 - Fuel Pump (see Fuel Pump Installation)
 - Fuel Tank (see Fuel Tank Installation)

3-138 FUEL SYSTEM (DFI)

Evaporative Emission Control System (CAL and SEA-B1 Models)

The Evaporative Emission Control System routes fuel vapors from the fuel system into the running engine or stores the vapors in a canister when the engine is stopped. Although no adjustments are required, a thorough visual inspection must be made at the intervals specified by the Periodic Maintenance Chart.

Parts Removal/Installation

⚠ WARNING

Gasoline is extremely flammable and can be explosive under certain conditions. Turn the ignition switch OFF. Do not smoke. Make sure the area is well-ventilated and free from any source of flame or sparks; this includes any appliance with a pilot light.

NOTICE

If gasoline, solvent, water or any other liquid enters the canister, the canister's vapor absorbing capacity is greatly reduced. If the canister does become contaminated, replace it with a new one.

- To prevent the gasoline from flowing into or out of the canister, hold the separator perpendicular to the ground.
- Connect the hoses according to the diagram of the system (see Cable, Wire, and Hose Routing section in the Appendix chapter). Make sure they do not get pinched or kinked.

Hose Inspection

- Refer to the Evaporative Emission Control System Inspection in the Periodic Maintenance chapter.

Separator Inspection

- Refer to the Evaporative Emission Control System Inspection in the Periodic Maintenance chapter.

Evaporative Emission Control System (CAL and SEA-B1 Models)

Separator Operation Test

⚠ WARNING

Gasoline is extremely flammable and can be explosive under certain conditions. Turn the ignition switch OFF. Do not smoke. Make sure the area is well-ventilated and free from any source of flame or sparks; this includes any appliance with a pilot light.

- Connect the hoses to the separator, and install the separator on the motorcycle.
- Disconnect the breather hose from the separator, and inject about 20 mL (0.68 US oz.) of gasoline [A] into the separator [B] through the hose fitting.
- Disconnect the fuel return hose [C] from the fuel tank [D].
- Run the open end of the return hose into the container and hold it level with the tank top [E].
- Start the engine, and let it idle.
- ★ If the gasoline in the separator comes out of the hose, the separator works well. If it does not, replace the separator with a new one.

Canister Inspection

- Refer to the Evaporative Emission Control System (CAL and SEA-B1 Models) Inspection in the Periodic Maintenance chapter.

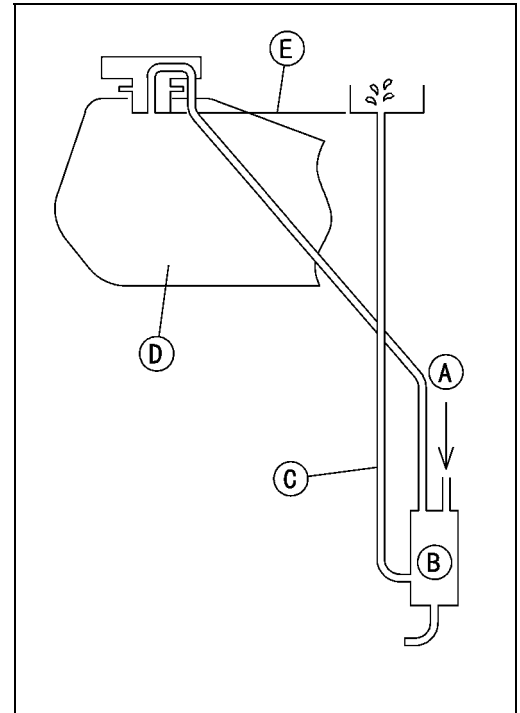

3-140 FUEL SYSTEM (DFI)

Evaporative Emission Control System (CAL and SEA-B1 Models)

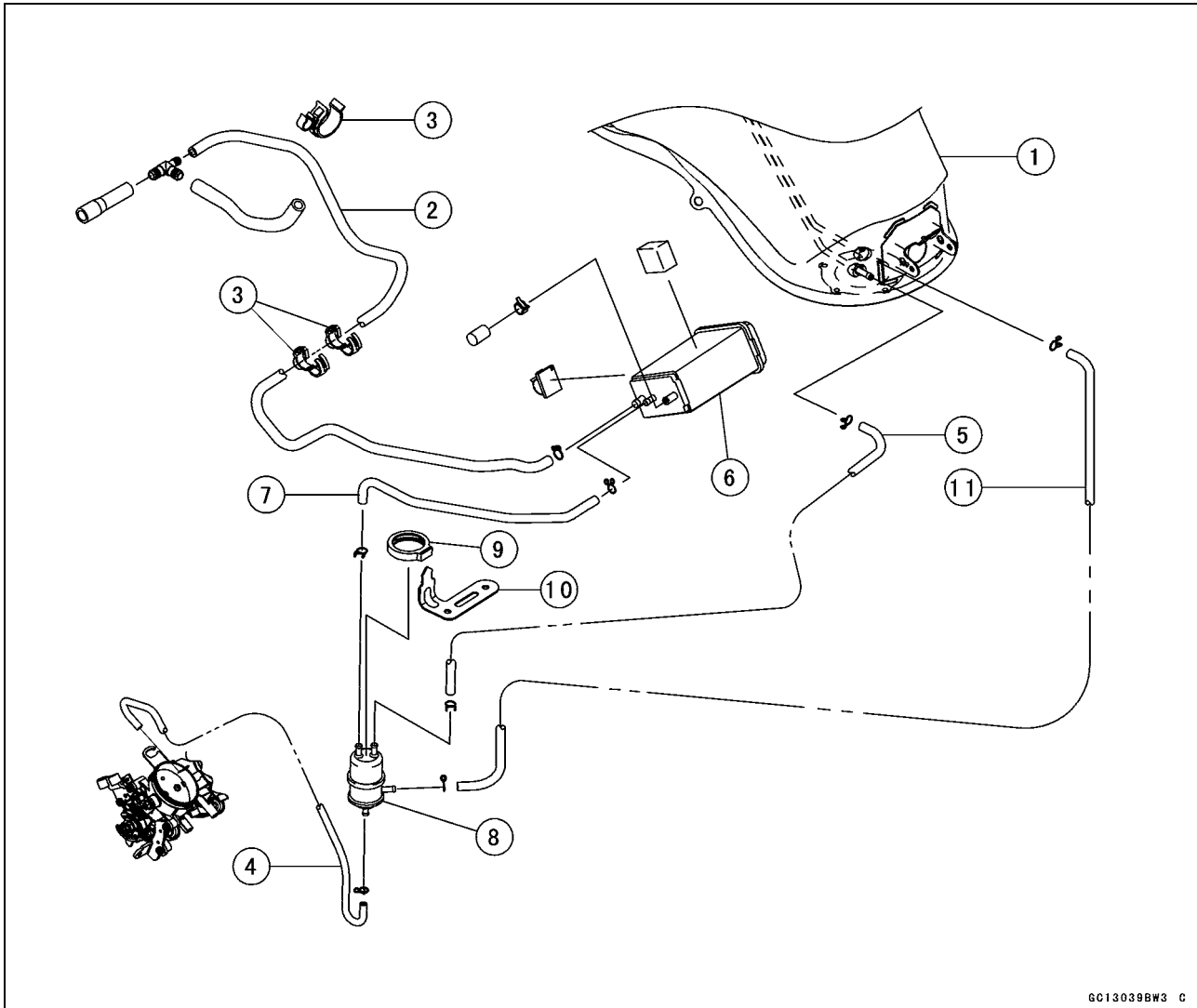

1. Fuel Tank
2. Green Hose (Purge)
3. Clamps
4. White Hose (Vacuum)
5. Blue Hose (Breather)
6. Canister
7. Blue Hose (Breather)
8. Separator
9. Damper (for Separator)
10. Bracket (for Separator)
11. Red Hose (Return)

Cooling System

Table of Contents

Exploded View.....	4-2
Coolant Flow Chart.....	4-4
Specifications	4-6
Special Tools	4-7
Coolant	4-8
Coolant Deterioration Inspection.....	4-8
Coolant Level Inspection.....	4-8
Coolant Draining	4-8
Coolant Filling	4-8
Pressure Testing	4-8
Cooling System Flushing	4-9
Coolant Reserve Tank Removal/Installation	4-9
Water Pump.....	4-10
Water Pump Removal.....	4-10
Water Pump Installation	4-10
Water Pump Inspection.....	4-12
Water Pump Impeller Disassembly/Assembly	4-12
Water Pump Impeller Inspection	4-12
Water Pump Housing Disassembly	4-12
Water Pump Housing Assembly	4-13
Mechanical Seal Inspection	4-13
Radiator	4-14
Radiator and Radiator Fan Removal	4-14
Radiator and Radiator Fan Installation	4-16
Radiator Inspection	4-17
Radiator Cap Inspection	4-17
Radiator Filler Neck Inspection	4-18
Thermostat	4-19
Thermostat Removal.....	4-19
Thermostat Installation.....	4-19
Thermostat Inspection	4-20
Hose and Pipes	4-21
Hose Installation	4-21
Hose Inspection	4-21
Water Temperature Sensor	4-22
Water Temperature Sensor Removal/Installation	4-22
Water Temperature Sensor Inspection	4-22

4-2 COOLING SYSTEM

Exploded View

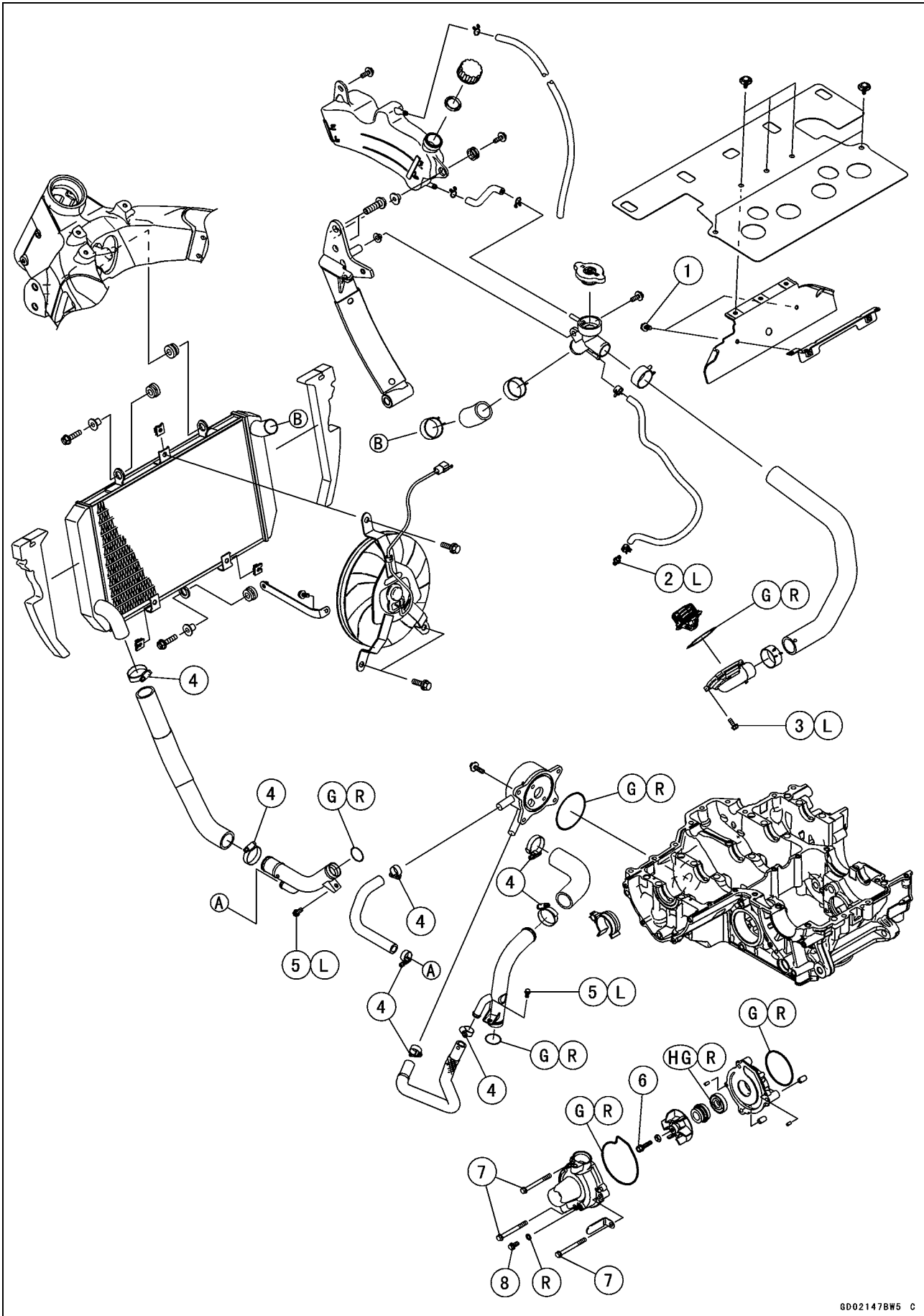

Exploded View

No.	Fastener	Torque			Remarks
		N·m	kgf·m	ft·lb	
1	Hot Windshield Mounting Bolts	9.8	1.0	87 in·lb	
2	Coolant By-pass Fitting Bolt	8.8	0.90	78 in·lb	L
3	Thermostat Housing Bolts	5.9	0.60	52 in·lb	L
4	Radiator (Water) Hose Clamp Screws	2.9	0.30	26 in·lb	
5	Water Pipe Bolts	12	1.2	106 in·lb	L
6	Water Pump Impeller Bolt	9.8	1.0	87 in·lb	
7	Water Pump Cover Bolts	11	1.1	97 in·lb	
8	Coolant Drain Bolt	11	1.1	97 in·lb	

G: Apply grease.

HG: Apply high-temperature grease.

L: Apply a non-permanent locking agent.

R: Replacement Parts

4-4 COOLING SYSTEM

Coolant Flow Chart

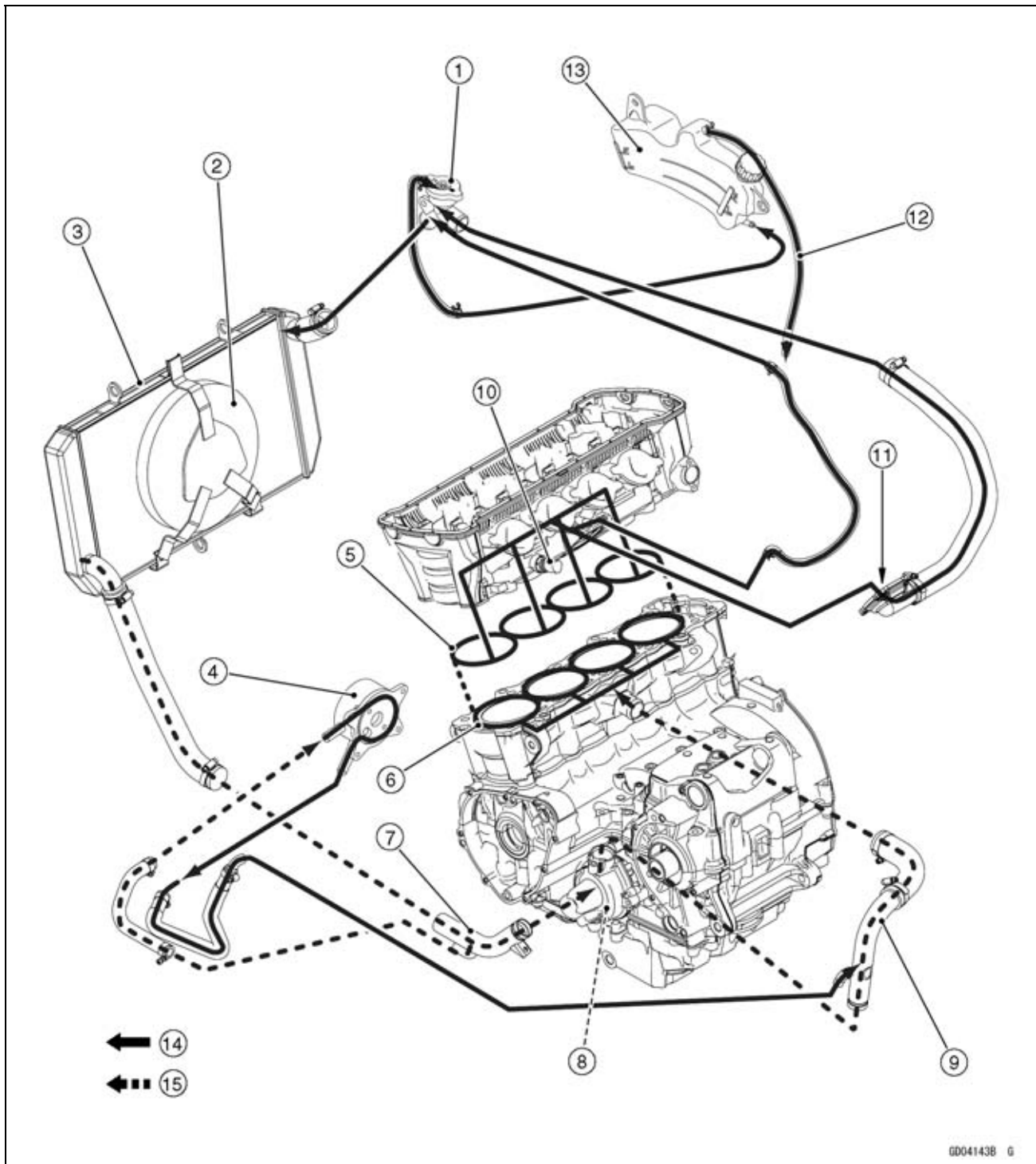

- 1. Radiator Cap
- 2. Radiator Fan
- 3. Radiator
- 4. Oil Cooler
- 5. Cylinder Head Jacket
- 6. Cylinder Jacket
- 7. Inlet Pipe
- 8. Water Pump

- 9. Outlet Pipe
- 10. Water Temperature Sensor
- 11. Thermostat Housing
- 12. Reserve Tank Overflow Hose
- 13. Reserve Tank
- 14. Hot Coolant
- 15. Cold Coolant

Coolant Flow Chart

Permanent type antifreeze is used as a coolant to protect the cooling system from rust and corrosion. When the engine starts, the water pump turns and the coolant circulates.

The thermostat is a wax pellet type which opens or closes with coolant temperature changes. The thermostat continuously changes its valve opening to keep the coolant temperature at the proper level. When coolant temperature is less than 55°C (131°F), the thermostat closes so that the coolant flow is restricted through the air bleeder hole, causing the engine to warm up more quickly. When coolant temperature is more than 58 ~ 62°C (136 ~ 144°F), the thermostat opens and the coolant flows.

When the coolant temperature goes up beyond 100°C (212°F), the radiator fan relay conducts to operate the radiator fan. The radiator fan draws air through the radiator core when there is not sufficient air flow such as at low speeds. This increases up the cooling action of the radiator. When the coolant temperature is below 97.5°C (208°F), the fan relay opens and the radiator fan stops.

In this way, this system controls the engine temperature within narrow limits where the engine operates most efficiently even if the engine load varies.

The system is pressurized by the radiator cap to suppress boiling and the resultant air bubbles which can cause engine overheating. As the engine warms up, the coolant in the radiator and the water jacket expands. The excess coolant flows through the radiator cap and hose to the reserve tank to be stored there temporarily. Conversely, as the engine cools down, the coolant in the radiator and the water jacket contracts, and the stored coolant flows back to the radiator from the reserve tank.

The radiator cap has two valves. One is a pressure valve which holds the pressure in the system when the engine is running. When the pressure exceeds 93 ~ 123 kPa (0.95 ~ 1.25 kgf/cm², 13 ~ 18 psi), the pressure valve opens and releases the pressure to the reserve tank. As soon as pressure escapes, the valve closes, and keeps the pressure at 93 ~ 123 kPa (0.95 ~ 1.25 kgf/cm², 13 ~ 18 psi). When the engine cools down, another small valve (vacuum valve) in the cap opens. As the coolant cools, the coolant contracts to form a vacuum in the system. The vacuum valve opens and allows the coolant from the reserve tank to enter the radiator.

4-6 COOLING SYSTEM

Specifications

Item	Standard
Coolant Provided when Shipping Type (Recommended) Color Mixed Ratio Freezing Point Total Amount	Permanent type of antifreeze (soft water and ethylene glycol plus corrosion and rust inhibitor chemicals for aluminum engines and radiators) Green Soft water 50%, coolant 50% -35°C (-31°F) 2.9 L (3.1 US qt) (reserve tank full level, including radiator and engine)
Radiator Cap Relief Pressure	93 ~ 123 kPa (0.95 ~ 1.25 kgf/cm ² , 13 ~ 18 psi)
Thermostat Valve Opening Temperature Valve Full Opening Lift	58 ~ 62°C (136 ~ 144°F) 8 mm (0.31 in.) or more at 75°C (167°F)

Special Tools

**Bearing Driver Set:
57001-1129**

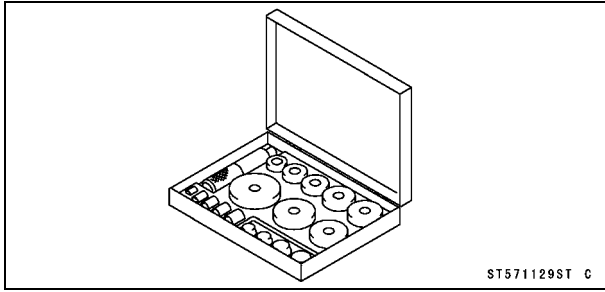

**Oil Seal Driver:
57001-1660**

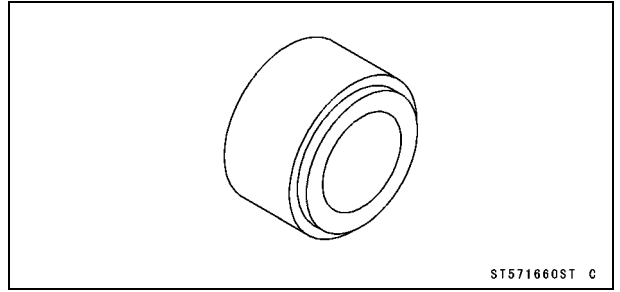

4-8 COOLING SYSTEM

Coolant

Coolant Deterioration Inspection

- Remove the right lower fairing (see Lower Fairing Removal in the Frame chapter).
- Visually inspect the coolant [A] in the reserve tank.
- ★ If whitish cotton-like wafts are observed, aluminum parts in the cooling system are corroded. If the coolant is brown, iron or steel parts are rusting. In either case, flush the cooling system.
- ★ If the coolant gives off an abnormal smell, check for a cooling system leak. It may be caused by exhaust gas leaking into the cooling system.



Coolant Level Inspection

- Refer to the Coolant Level in the Periodic Maintenance chapter.

Coolant Draining

- Refer to the Coolant Change in the Periodic Maintenance chapter.

Coolant Filling

- Refer to the Coolant Change in the Periodic Maintenance chapter.

Pressure Testing

- Remove the right lower fairing (see Lower Fairing Removal in the Frame chapter).
- Remove the radiator cap, and install a cooling system pressure tester [A] on the filler neck [B].

NOTE

○ Wet the cap sealing surfaces with water or coolant to prevent pressure leaks.

- Build up pressure in the system carefully until the pressure reaches 123 kPa (1.25 kgf/cm², 18 psi).

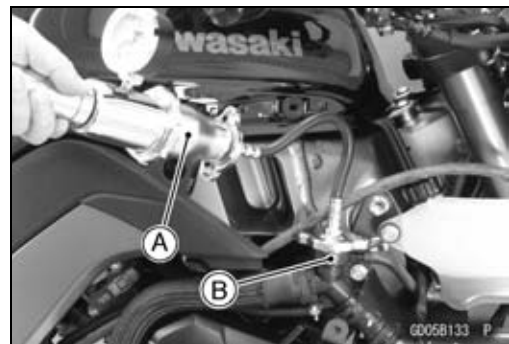

NOTICE

During pressure testing, do not exceed the pressure for which the system is designed. The maximum pressure is 123 kPa (1.25 kgf/cm², 18 psi).

- Watch the gauge for at least 6 seconds.
- ★ If the pressure holds steady, the system is all right.
- ★ If the pressure drops and no external source is found, check for internal leaks. Droplets in the engine oil indicate internal leakage. Check the cylinder head gasket and the water pump.
- Remove the pressure tester, replenish the coolant, and install the radiator cap.

Coolant

Cooling System Flushing

Over a period of time, the cooling system accumulates rust, scale, and lime in the water jacket and radiator. When this accumulation is suspected or observed, flush the cooling system. If this accumulation is not removed, it will clog up the water passage and considerably reduce the efficiency of the cooling system.

- Drain the cooling system (see Coolant Change in the Periodic Maintenance chapter).
- Fill the cooling system with fresh water mixed with a flushing compound.

NOTICE

Do not use a flushing compound which is harmful to the aluminum engine and radiator. Carefully follow the instructions supplied by the manufacturer of the cleaning product.

- Warm up the engine, and run it at normal operating temperature for about ten minutes.
- Stop the engine, and drain the cooling system.
- Fill the system with fresh water.
- Warm up the engine and drain the system.
- Repeat the previous two steps once more.
- Fill the system with a permanent type coolant and bleed the air from the system (see Coolant Change in the Periodic Maintenance chapter).

Coolant Reserve Tank Removal/Installation

- The coolant reserve tank is removed and installed during coolant change (see Coolant Change in the Periodic Maintenance chapter).

4-10 COOLING SYSTEM

Water Pump

Water Pump Removal

- Drain:
 - Coolant (see Coolant Change in the Periodic Maintenance chapter)
 - Engine Oil (see Engine Oil Change in the Periodic Maintenance chapter)
- Remove:
 - Left Lower Fairing (see Lower Fairing Removal in the Frame chapter)
 - Engine Sprocket Cover (see Engine Sprocket Cover Removal in the Final Drive chapter)
- Remove the water pipe bolts [A] to pull out the water pipes [B] from the water pump cover.
- Disconnect the neutral switch connector [C].
- Loosen the clamp bolt [D] to remove the water hose [E].
- Remove:
 - Water Pump Cover Bolts [A]
 - Water Pump Cover [B]

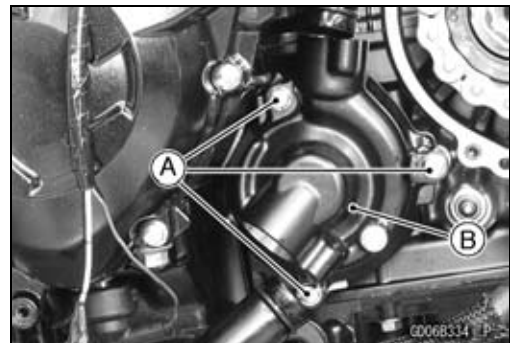
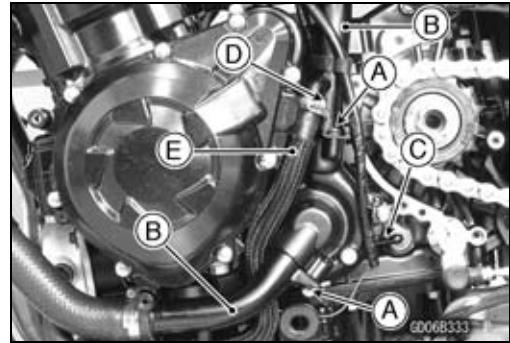

- Remove:
 - Water Pump Impeller Bolt [A] and Washer
 - Water Pump Impeller [B]
 - Water Pump Housing [C]

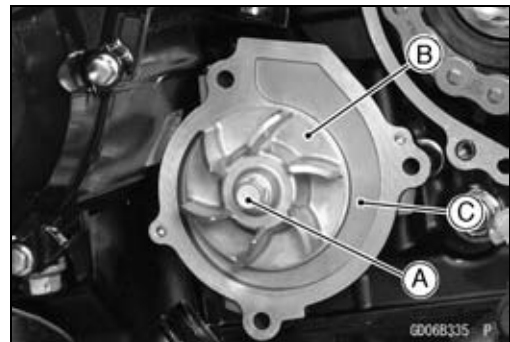

Water Pump Installation

- Replace the O-ring [A] with a new one, and install it.

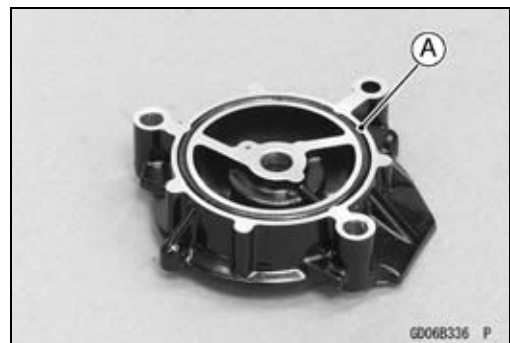

Water Pump

- Be sure to install the dowel pins [A].

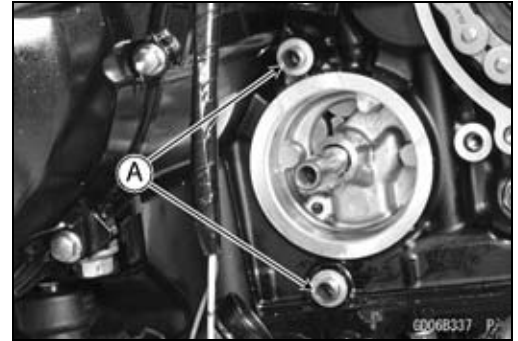

- Install:
 - Water Pump Housing [A]
 - Water Pump Impeller [B]
- Tighten:
 - Torque - Water Pump Impeller Bolt [C]: 9.8 N-m (1.0 kgf-m, 87 in-lb)**
- Be sure to install the dowel pins [D].

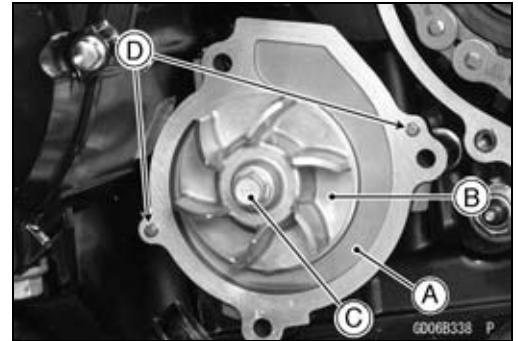

- Replace the O-ring [A] with a new one, and install it.



- Install the water pump cover [A].
- Tighten:
 - Torque - Water Pump Cover Bolts [B]: 11 N-m (1.1 kgf-m, 97 in-lb)**
- Replace the O-ring [C] with new ones.

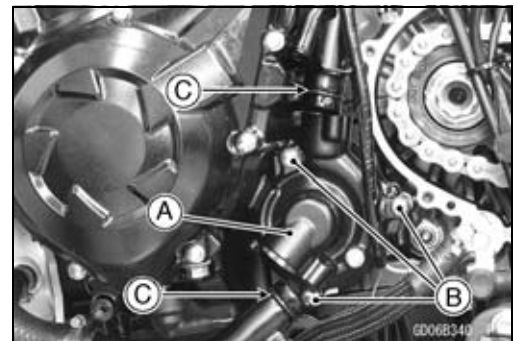

- Install the water pipes [A] to the water pump cover.
- Apply a non-permanent locking agent to the threads of the water pipe bolts [B], and tighten them.
- Torque - Water Pipe Bolts: 12 N-m (1.2 kgf-m, 106 in-lb)**
- Install the water hose [C].
- Tighten:
 - Torque - Water Hose Clamp Screw [D]: 2.9 N-m (0.30 kgf-m, 26 in-lb)**
- Connect the neutral switch connector [E].

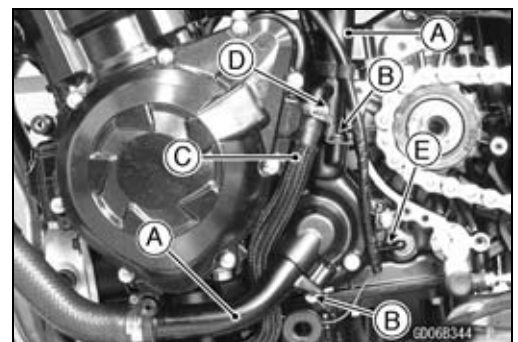

4-12 COOLING SYSTEM

Water Pump

Water Pump Inspection

- Remove the left lower fairing (see Lower Fairing Removal in the Frame chapter).
- Check the drainage outlet passage [A] at the bottom of the water pump body for coolant leaks.
- ★ If the mechanical seal is damaged, the coolant leaks through the seal and drains through the passage. Replace the mechanical seal unit.

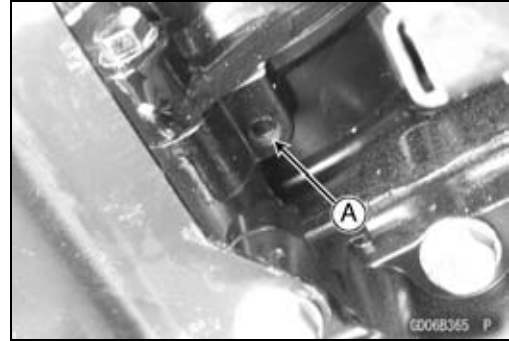

Water Pump Impeller Disassembly/Assembly

- Remove the water pump impeller (see Water Pump Removal).
- The sealing seat and rubber seal may be removed easily by hand.
- Apply coolant around the surfaces of the rubber seal and sealing seat.
- Install the rubber seal [A] and sealing seat [B] into the impeller by pressing them by hand until the seat stops at the bottom of the hole.
- Install the water pump impeller (see Water Pump Installation).

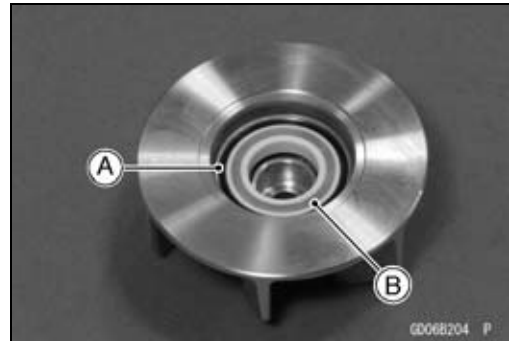

Water Pump Impeller Inspection

- Remove the water pump cover (see Water Pump Removal).
- Visually inspect the water pump impeller [A].
- ★ If the surface is corroded or if the blades are damaged, replace the impeller.



Water Pump Housing Disassembly

NOTICE

Do not damage the hole wall of the water pump housing.

- Insert a bar [A] into the pump housing [B], and hammer evenly around the circumference of the mechanical seal bottom [C].

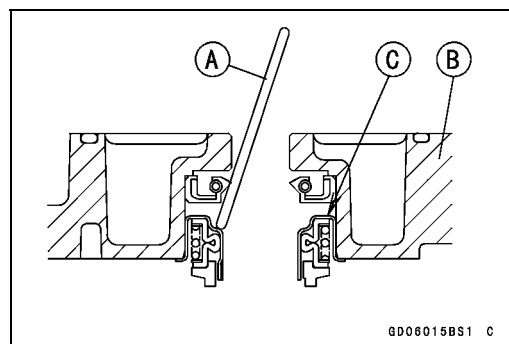

Water Pump

- Take the oil seal [A] out of the housing [B] with a hook [C].

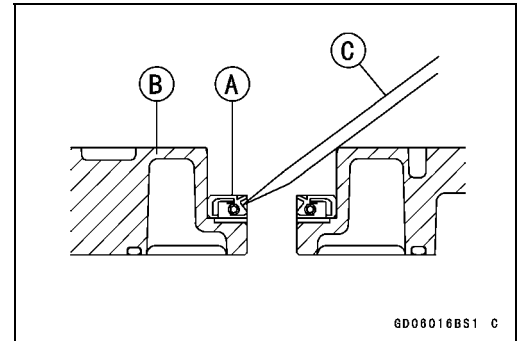

Water Pump Housing Assembly

NOTICE

Do not reuse the mechanical seal and oil seal.

- Apply high-temperature grease to the oil seal lips [A].
- Press the new oil seal into the housing with a bearing driver [B] until it stops at the bottom surface [C] of the housing.

Special Tool - Bearing Driver Set: 57001-1129

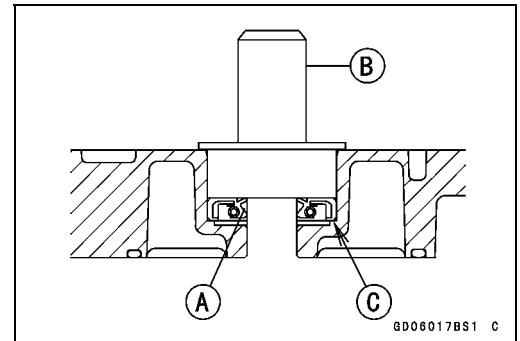

NOTICE

Be careful not to damage the sealing surface of the mechanical seal.

- Press the new mechanical seal into the housing with the oil seal driver [A] until its flange [B] touches the surface [C] of the housing.

Special Tool - Oil Seal Driver: 57001-1660

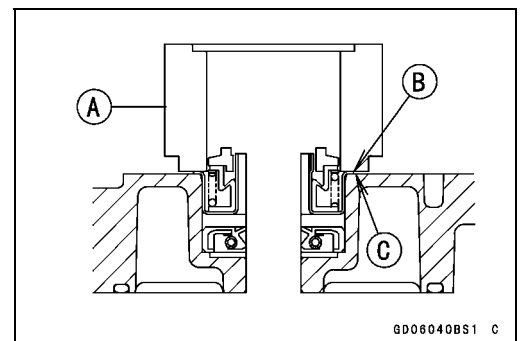

Mechanical Seal Inspection

- Remove the water pump impeller (see Water Pump Removal).
- Visually inspect the mechanical seal.
- ★ If any one of the parts is damaged, replace the mechanical seal as a unit.

- Impeller Sealing Seat Surface [A]
- Rubber Seal [B]
- Mechanical Seal [C]

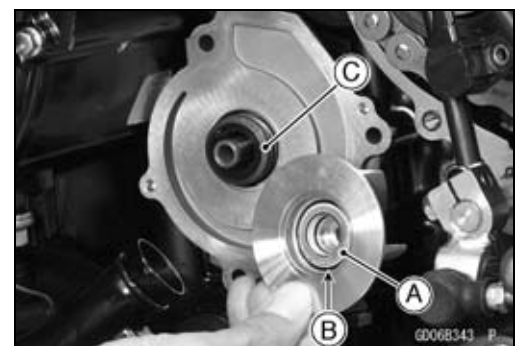

4-14 COOLING SYSTEM

Radiator

Radiator and Radiator Fan Removal

- Remove:
 - Lower Fairing (see Lower Fairing Removal in the Frame chapter)
 - Coolant (Drain, see Coolant Change in the Periodic Maintenance chapter)

- Remove:
 - Radiator Hose Clamp [A]
 - Radiator Cap Mounting Bolt [B]
 - Radiator Hose [C]

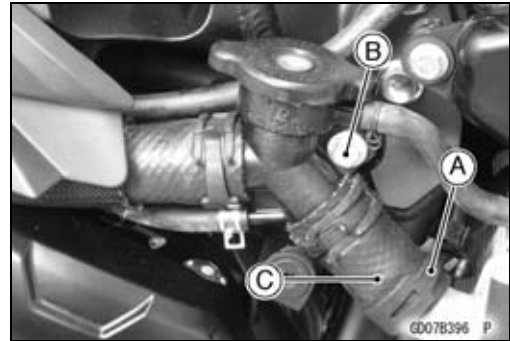

- Remove:
 - Radiator Upper Bolt [A]



- Move the radiator right ward [A] to clear the frame projection [B].

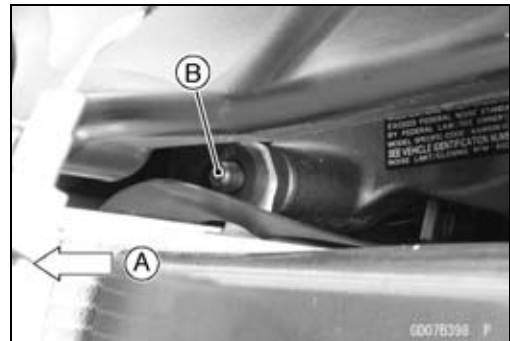

- Remove:
 - Rubber Band [A]

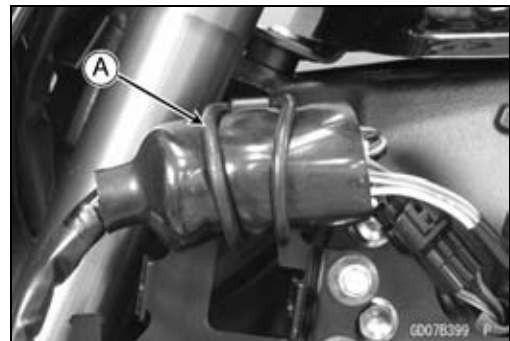

Radiator

- Slide the connector cover [A] to disconnect the radiator fan motor lead connector [B].

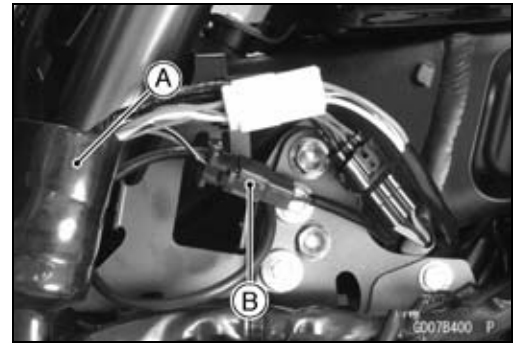

- Remove:
 Radiator Hose Clamp Screw [A] (Loosen)
 Radiator Hose [B]
 Radiator Lower Bolt [C]

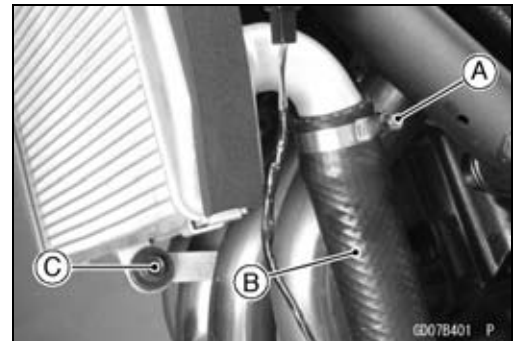

NOTICE

Do not touch the radiator core. This could damage the radiator fins, resulting in loss of cooling efficiency.

- Remove:
 Radiator Fan Mounting Bolts [A]
 Radiator Fan [B]

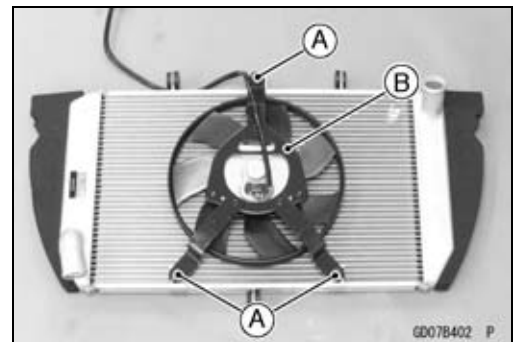

4-16 COOLING SYSTEM

Radiator

Radiator and Radiator Fan Installation

- Installation is the reverse of removal.
- Install the rubber dampers [A] and radiator bracket collars [B] as shown in the figure.
 - [C] Larger
 - [D] Smaller

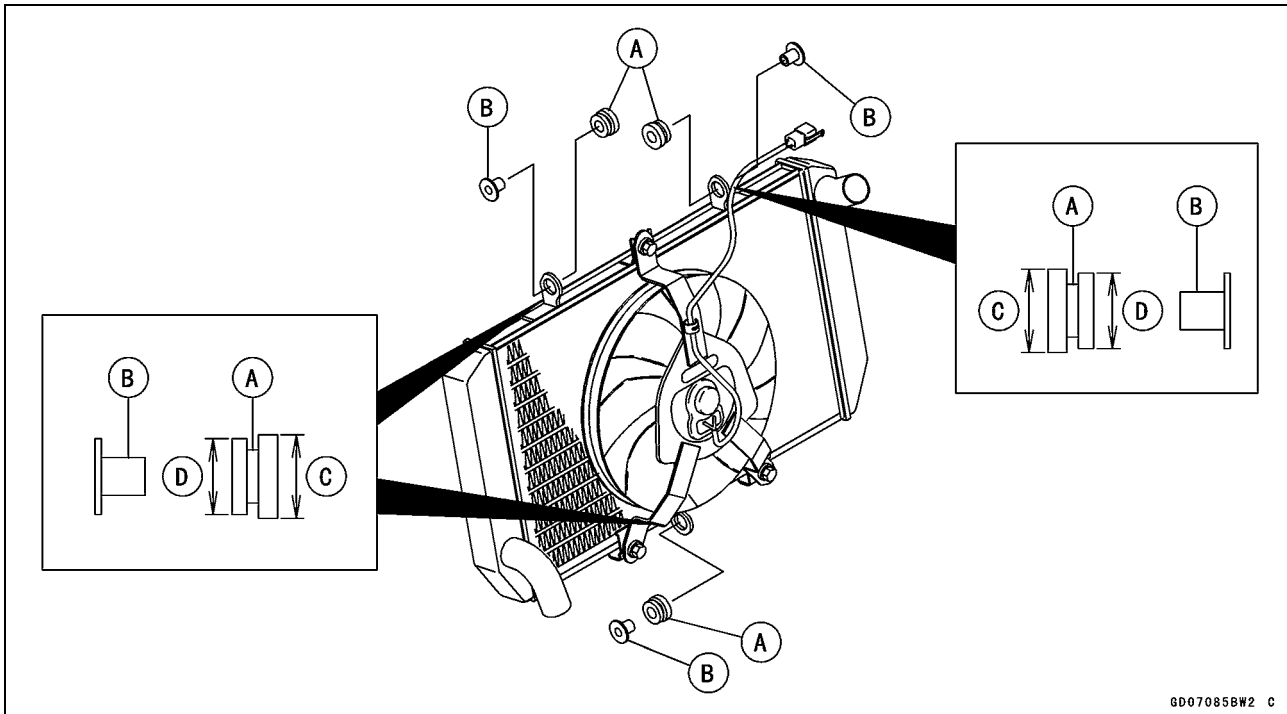

- Fit the slits [A] of the heat insulation rubber plate to the upper mounting brackets [B] and fan bracket [C] as shown.

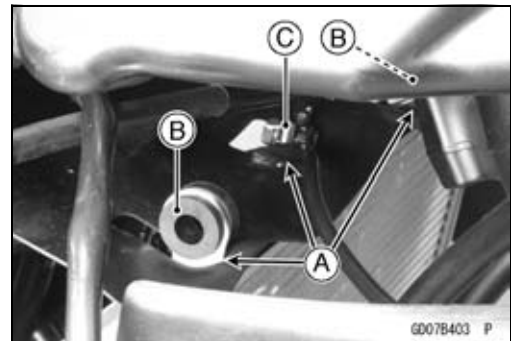

- Insert the upper right mounting bracket [A] to the frame projection [B].
- Tighten the radiator bolts securely.
- Connect the radiator fan connector.
- Install the removed parts (see appropriate chapter).

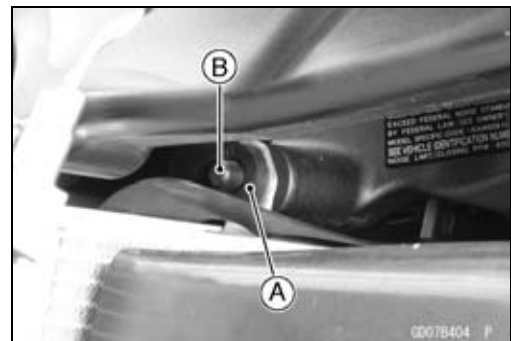

Radiator

Radiator Inspection

- Check the radiator core.
- ★ If there are obstructions to air flow, remove them.
- ★ If the corrugated fins [A] are deformed, carefully straighten them.
- ★ If the air passages of the radiator core are blocked more than 20% by unremovable obstructions or irreparably deformed fins, replace the radiator with a new one.

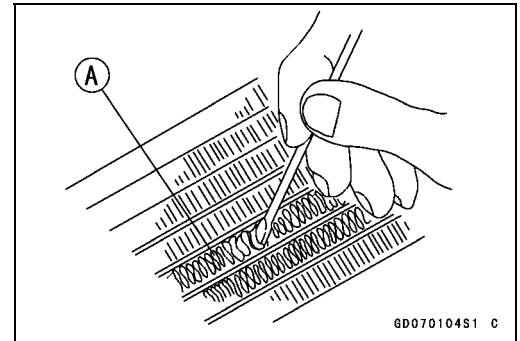

NOTICE

When cleaning the radiator with steam cleaner, be careful of the following to prevent radiator damage: Keep the steam gun [A] away more than 0.5 m (1.6 ft) [B] from the radiator core. Hold the steam gun perpendicular [C] (not oblique [D]) to the core surface. Run the steam gun, following the core fin direction.

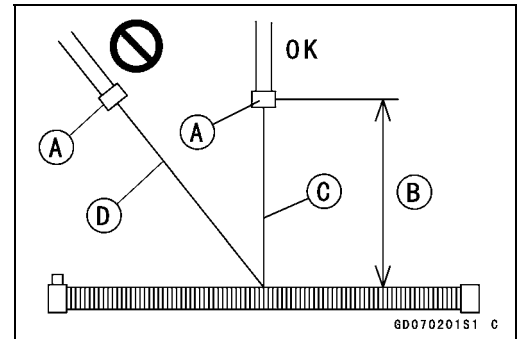

Radiator Cap Inspection

- Remove:
 - Right Lower Fairing (see Lower Fairing Removal in the Frame chapter)
 - Radiator Cap
 - Check the condition of the bottom [A] and top [B] valve seals and valve spring [C].
 - ★ If any one of them shows visible damage, replace the cap with a new one.
- Install the cap [A] on a cooling system pressure tester [B].

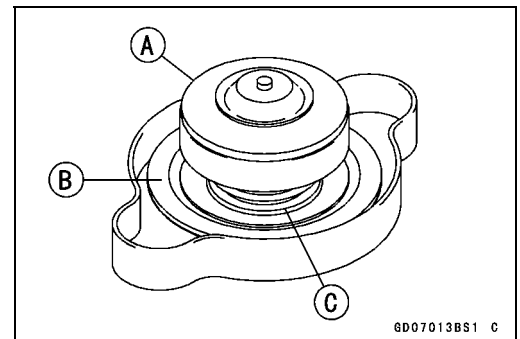

NOTE

- Wet the cap sealing surfaces with water or coolant to prevent pressure leaks.
- Watching the pressure gauge, pump the pressure tester to build up the pressure until the relief valve opens: the gauge needle flicks downward. Stop pumping and measure leak time at once. The relief valve must open within the specified range in the table below and the gauge hand must remain within the same range at least 6 seconds.

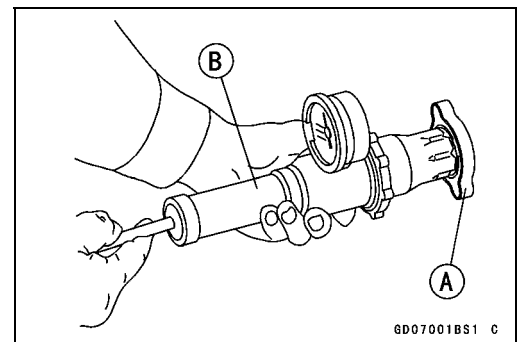

Radiator Cap Relief Pressure

Standard: 93 ~ 123 kPa (0.95 ~ 1.25 kgf/cm², 13 ~ 18 psi)

- ★ If the cap can not hold the specified pressure or if it holds too much pressure, replace it with a new one.

4-18 COOLING SYSTEM

Radiator

Radiator Filler Neck Inspection

- Remove:
 - Right Lower Fairing (see Lower Fairing Removal in the Frame chapter)
 - Radiator Cap
- Check the radiator filler neck for signs of damage.
- Check the condition of the top and bottom sealing seats [A] in the filler neck. They must be smooth and clean for the radiator cap to function properly.



Thermostat

Thermostat Removal

- Remove:
 - Coolant (Drain, see Coolant Change in the Periodic Maintenance chapter)
 - Engine Sprocket Cover (see Engine Sprocket Removal in the Final Drive chapter)
 - Harness Holder Clamp [A]
 - Water Hose Clamp [B]
 - Water Hose [C]
 - Water Pipe Bolts [D]
 - Water Pipe [E]
- Loosen the water hose clamp screw [A].
- Clear the starter motor cable from the holder [B].

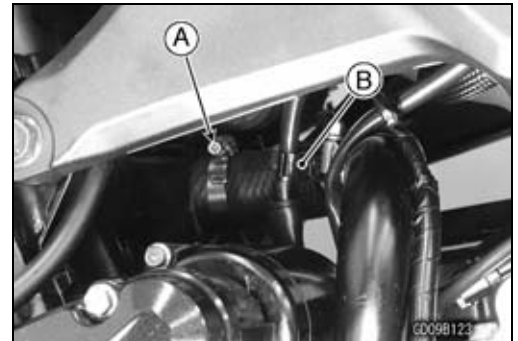
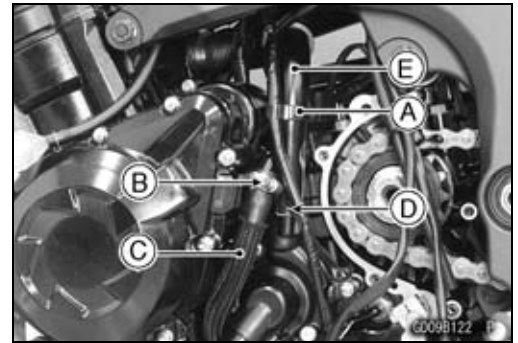

- Remove:
 - Thermostat Housing Bolts [A]
 - Thermostat Housing Cover [B]
 - Thermostat

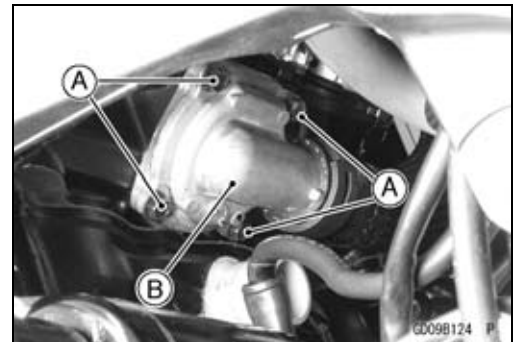

Thermostat Installation

- Install the thermostat [A] in the housing so that the air bleeder hole [B] is on top.

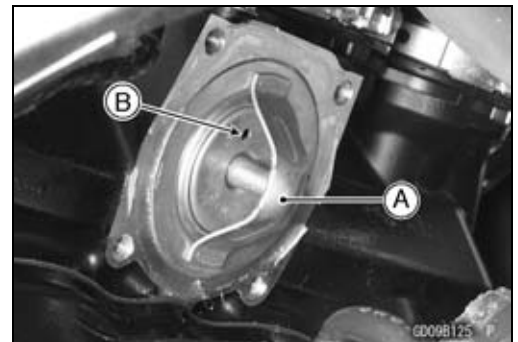

4-20 COOLING SYSTEM

Thermostat

- Replace the O-ring [A] with a new one.
- Apply grease to the O-ring, and install it.
- Install the thermostat housing cover.

NOTE

○ Note that the thermostat does not move at the place when installing the thermostat housing cover.

- Tighten:

Torque - Thermostat Housing Bolts: 5.9 N·m (0.60 kgf·m, 52 in·lb)

- Apply a non-permanent locking agent to the threads of the water pipe bolt.

- Tighten:

Torque - Water Pipe Bolt: 12 N·m (1.2 kgf·m, 106 in·lb)

Radiator (Water) Hose Clamp Screws: 2.9 N·m (0.30 kgf·m, 26 in·lb)

- Run the hoses correctly (see Cable, Wire, and Hose Routing section in the Appendix chapter).
- Fill the radiator with coolant (see Coolant Change in the Periodic Maintenance chapter).

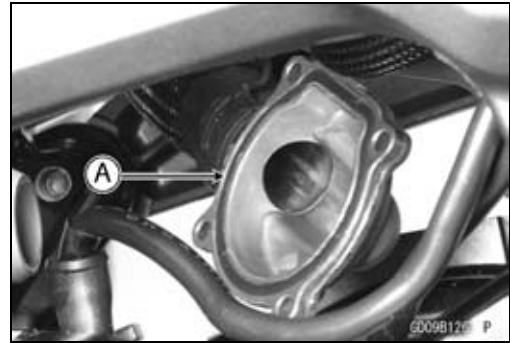

Thermostat Inspection

- Remove the thermostat (see Thermostat Removal), and inspect the thermostat valve [A] at room temperature.
- ★ If the valve is open, replace the thermostat with a new one.

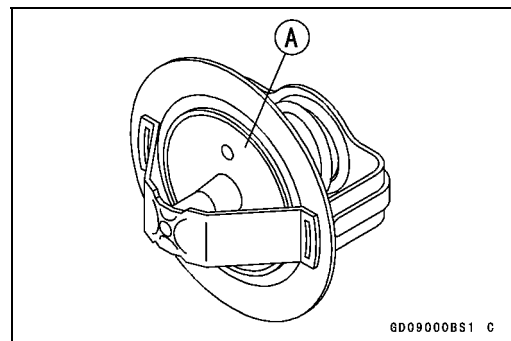

- To check valve opening temperature, suspend the thermostat [A] in a container of water and raise the temperature of the water.
- The thermostat must be completely submerged and must not touch the container sides or bottom. Suspend an accurate thermometer [B] in the water so that the heat sensitive portions [C] are located in almost the same depth. It must not touch the container, either.
- ★ If the measurement is out of the specified range, replace the thermostat with a new one.

Thermostat Valve Opening Temperature

58 ~ 62°C (136 ~ 144°F)

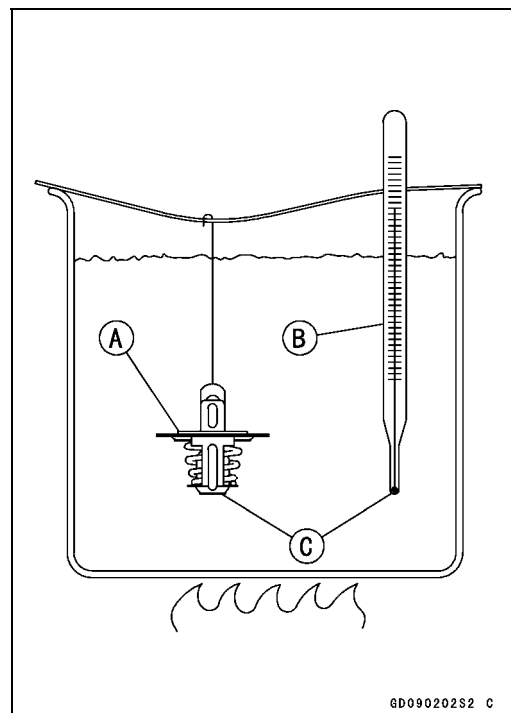

Hose and Pipes

Hose Installation

- Install the hoses and pipes, being careful to follow bending direction. Avoid sharp bending, kinking, flattening or twisting.
- Run the hoses (see Cable, Wire, and Hose Routing section in the Appendix chapter).
- Install the clamp [A] as near as possible to the hose end to clear the raised rib of the fitting. This will prevent the hoses from working loose.
- The clamp screws should be positioned correctly to prevent the clamps from contacting the other parts.

**Torque - Radiator (Water) Hose Clamp Screws: 2.9 N·m
(0.30 kgf·m, 26 in·lb)**

Hose Inspection

- Refer to the Radiator Hose Damage and Installation Condition Inspection in the Periodic Maintenance chapter.

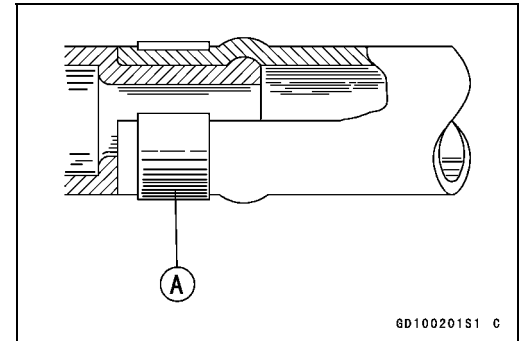

4-22 COOLING SYSTEM

Water Temperature Sensor

NOTICE

The water temperature sensor should never be allowed to fall on a hard surface. Such a shock to the water temperature sensor can damage it.

Water Temperature Sensor Removal/Installation

- Refer to the Water Temperature Sensor Removal/Installation in the Fuel System (DFI) chapter.

Water Temperature Sensor Inspection

- Refer to the Water Temperature Sensor Inspection in the Electrical System chapter.

Engine Top End

Table of Contents

Exploded View.....	5-2	Valve Clearance Inspection	5-30
Exhaust System Identification	5-6	Valve Clearance Adjustment.....	5-30
Specifications	5-8	Valve Removal	5-30
Special Tools and Sealant	5-10	Valve Installation	5-30
Clean Air System.....	5-12	Valve Guide Removal	5-30
Air Suction Valve Removal.....	5-12	Valve Guide Installation	5-31
Air Suction Valve Installation.....	5-12	Valve-to-Guide Clearance	
Air Suction Valve Inspection	5-13	Measurement (Wobble	
Air Switching Valve Removal	5-13	Method)	5-32
Air Switching Valve Installation ...	5-13	Valve Seat Inspection	5-32
Air Switching Valve Operation		Valve Seat Repair	5-33
Test.....	5-13	Cylinder, Pistons.....	5-38
Air Switching Valve Unit Test	5-13	Cylinder Removal.....	5-38
Clean Air System Hose		Cylinder Installation.....	5-38
Inspection.....	5-14	Piston Removal.....	5-39
Cylinder Head Cover	5-15	Piston Installation.....	5-40
Cylinder Head Cover Removal ...	5-15	Cylinder Wear Inspection.....	5-40
Cylinder Head Cover Installation .	5-16	Piston Wear Inspection	5-41
Camshaft Chain Tensioner	5-19	Piston Ring, Piston Ring Groove	
Camshaft Chain Tensioner		Wear Inspection	5-41
Removal.....	5-19	Piston Ring Groove Width	
Camshaft Chain Tensioner		Inspection.....	5-41
Installation	5-19	Piston Ring Thickness Inspection	5-42
Camshaft, Camshaft Chain	5-20	Piston Ring End Gap Inspection ..	5-42
Camshaft Removal	5-20	Throttle Body Assy Holder.....	5-43
Camshaft Installation	5-21	Throttle Body Assy Holder	
Camshaft, Camshaft Cap Wear		Removal.....	5-43
Inspection.....	5-24	Throttle Body Assy Holder	
Camshaft Runout Inspection.....	5-24	Installation	5-43
Cam Wear Inspection	5-25	Muffler.....	5-44
Camshaft Chain Removal	5-25	Muffler Body Removal.....	5-44
Cylinder Head.....	5-26	Muffler Body Installation.....	5-45
Cylinder Compression		Exhaust Pipe Removal.....	5-47
Measurement	5-26	Exhaust Pipe Installation.....	5-47
Cylinder Head Removal	5-27	Exhaust Butterfly Valve Cable	
Cylinder Head Installation	5-27	Removal	5-47
Cylinder Head Warp Inspection ...	5-29	Exhaust Butterfly Valve Cable	
Valves	5-30	Installation	5-48

5-2 ENGINE TOP END

Exploded View

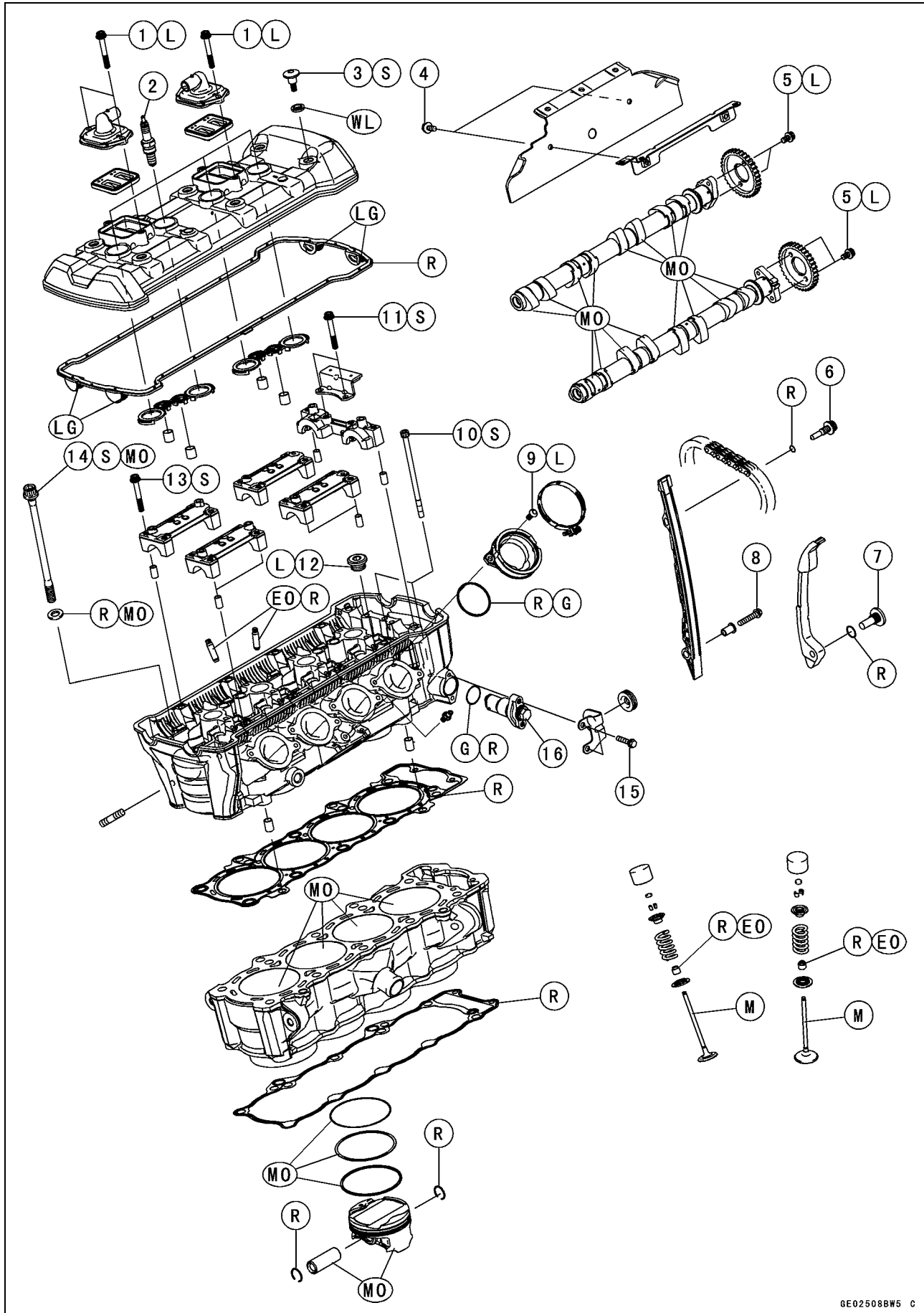

Exploded View

No.	Fastener	Torque			Remarks
		N·m	kgf·m	ft·lb	
1	Air Suction Valve Cover Bolts	9.8	1.0	87 in·lb	L
2	Spark Plugs	13	1.3	115 in·lb	
3	Cylinder Head Cover Bolts	9.8	1.0	87 in·lb	S
4	Hot Windshield Mounting Bolts	9.8	1.0	87 in·lb	
5	Camshaft Sprocket Bolts	15	1.5	11	L
6	Front Camshaft Chain Guide Bolt (Upper)	25	2.5	18	
7	Rear Camshaft Chain Guide Bolt	25	2.5	18	
8	Front Camshaft Chain Guide Bolt (Lower)	12	1.2	106 in·lb	
9	Throttle Body Assy Holder Bolts	12	1.2	106 in·lb	L
10	Cylinder Head Bolts (M6)	12	1.2	106 in·lb	S
11	Upper Camshaft Chain Guide Bolts	12	1.2	106 in·lb	S
12	Plugs	19.6	2.0	14	L
13	Camshaft Cap Bolts	12	1.2	106 in·lb	S
14	Cylinder Head Bolts (M10) (First)	20	2.0	15	S, MO
	Cylinder Head Bolts (M10) (Final)	54	5.5	40	S, MO
15	Camshaft Chain Tensioner Mounting Bolts	11	1.1	97 in·lb	
16	Camshaft Chain Tensioner Cap Bolt	20	2.0	15	

EO: Apply engine oil.

G: Apply grease.

L: Apply a non-permanent locking agent.

LG: Apply liquid gasket.

M: Apply molybdenum disulfide grease.

MO: Apply molybdenum disulfide oil solution.

(mixture of the engine oil and molybdenum disulfide grease in a weight ratio 10 : 1)

R: Replacement Parts

S: Follow the specified tightening sequence.

WL: Apply soap and water solution or rubber lubricant.

5-4 ENGINE TOP END

Exploded View

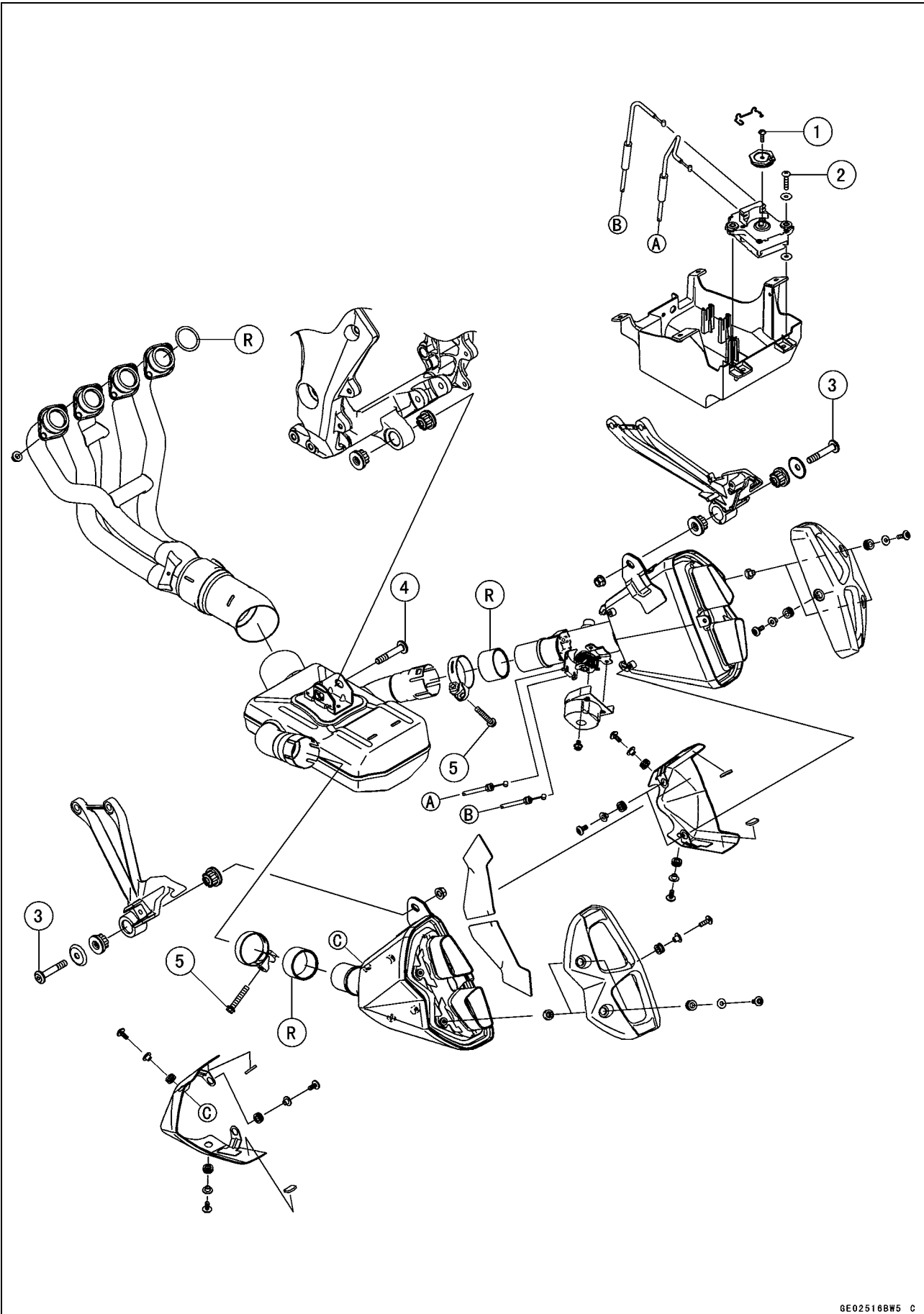

Exploded View

No.	Fastener	Torque			Remarks
		N·m	kgf·m	ft·lb	
1	Exhaust Butterfly Valve Actuator Pulley Bolt	5.0	0.51	44 in·lb	
2	Exhaust Butterfly Valve Actuator Bolts	1.2	0.12	11 in·lb	
3	Muffler Body Mounting Bolts	34	3.5	25	
4	Premuffler Chamber Mounting Bolt	34	3.5	25	
5	Muffler Body Clamp Bolts	21	2.1	15	

R: Replacement Parts

5-6 ENGINE TOP END

Exhaust System Identification

MANIFOLD	MUFFLER BODY	SPECIFICATION	MODEL
Honeycomb Type Catalyst with Oxygen Sensor P/No. 39178-0164 Mark: KHI M 131	Non-Catalyst P/No. 18091-0704 18091-0776 Mark: KHI K 606 EPA Noise Emission Control Information	WVTA (FULL H) GB WVTA (FULL H) WVTA (78.2 H) SEA AU BR	ZX1000GB ~/HB ~ ZX1000GB ~/HB ~ ZX1000GB ~/HB ~ ZX1000GB/HB ZX1000HB ZX1000GC/HC
		Honeycomb Type Catalyst without Oxygen Sensor P/No. 39178-0166 Mark: KHI M 132	Non-Catalyst P/No. 18091-0704 18091-0776 Mark: KHI K 606 EPA Noise Emission Control Information
	Non-Catalyst P/No. 18091-0858 18091-0859 Mark: KHI K 606 EPA Noise Emission Control Information	CAL CA US SEA-B1/B2 AU	ZX1000GC ZX1000GC/HC ZX1000GC/HC ZX1000GC/HC ZX1000HC

GE24704B F

Exhaust Pipe Mark Position [A]

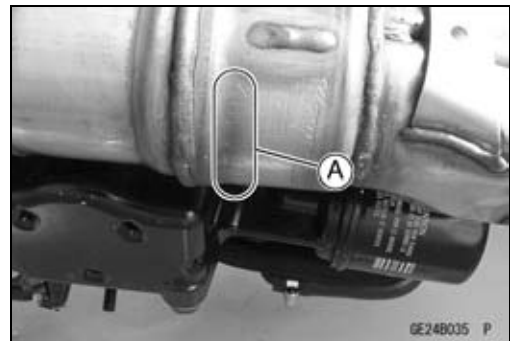

GE248035 P

Left Muffler Body Mark Position [A]



GE248036 P

Exhaust System Identification

Right Muffler Body Mark Position [A]

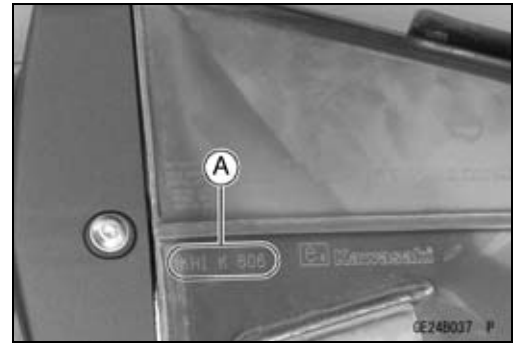

Exhaust Pipe [A] with Hole [B] for Oxygen Sensor [C]
(Equipped Models)

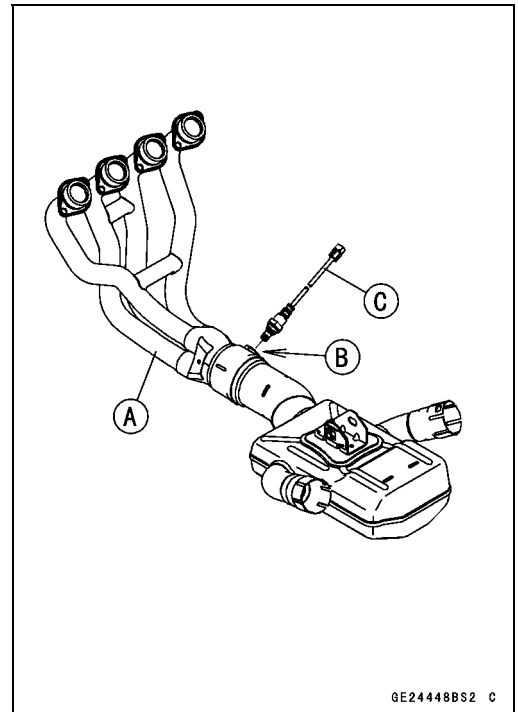

Honeycomb Type Catalyst Positions [A]

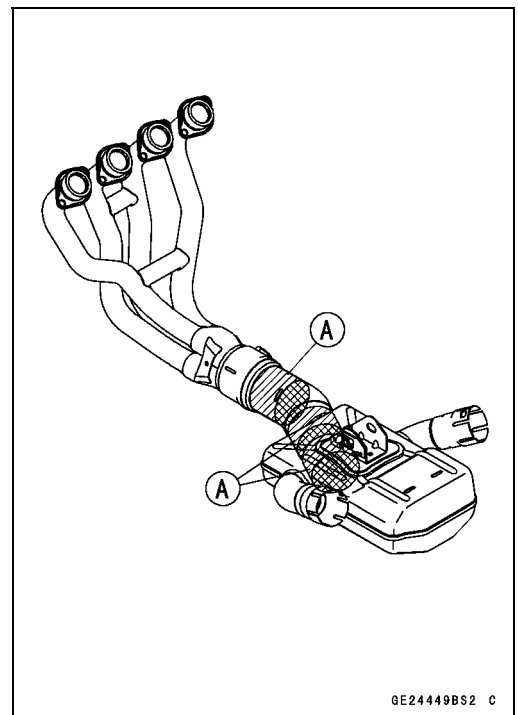

5-8 ENGINE TOP END

Specifications

Item	Standard	Service Limit
Camshafts		
Cam Height:		
Exhaust	33.743 ~ 33.857 mm (1.3285 ~ 1.3330 in.)	33.64 mm (1.324 in.)
Intake	34.743 ~ 34.857 mm (1.3678 ~ 1.3723 in.)	34.64 mm (1.364 in.)
Camshaft Journal, Camshaft Cap Clearance	0.038 ~ 0.081 mm (0.0015 ~ 0.0032 in.)	0.17 mm (0.0067 in.)
Camshaft Journal Diameter	23.940 ~ 23.962 mm (0.9425 ~ 0.9434 in.)	23.91 mm (0.9413 in.)
Camshaft Bearing Inside Diameter	24.000 ~ 24.021 mm (0.9449 ~ 0.9457 in.)	24.08 mm (0.9480 in.)
Camshaft Runout	TIR 0.02 mm (0.0008 in.) or less	TIR 0.1 mm (0.004 in.)
Cylinder Head		
Cylinder Compression	(Usable Range) 966 ~ 1 478 kPa (9.9 ~ 15.1 kgf/cm ² , 140 ~ 214 psi) at 280 r/min (rpm)	— — —
Cylinder Head Warp	— — —	0.05 mm (0.002 in.)
Valves		
Valve Clearance:		
Exhaust	0.22 ~ 0.31 mm (0.0087 ~ 0.0122 in.)	— — —
Intake	0.15 ~ 0.24 mm (0.0059 ~ 0.0094 in.)	— — —
Valve Head Thickness:		
Exhaust	0.8 mm (0.031 in.)	0.6 mm (0.024 in.)
Intake	0.5 mm (0.020 in.)	0.3 mm (0.012 in.)
Valve Stem Bend	TIR 0.01 mm (0.0004 in.) or less	TIR 0.05 mm (0.002 in.)
Valve Stem Diameter:		
Exhaust	4.455 ~ 4.470 mm (0.1754 ~ 0.1760 in.)	4.44 mm (0.175 in.)
Intake	4.475 ~ 4.490 mm (0.1762 ~ 0.1768 in.)	4.46 mm (0.176 in.)
Valve Guide Inside Diameter:		
Exhaust	4.500 ~ 4.512 mm (0.1772 ~ 0.1776 in.)	4.58 mm (0.180 in.)
Intake	4.500 ~ 4.512 mm (0.1772 ~ 0.1776 in.)	4.58 mm (0.180 in.)
Valve/Valve Guide Clearance (Wobble Method):		
Exhaust	0.08 ~ 0.14 mm (0.0031 ~ 0.0055 in.)	0.31 mm (0.012 in.)
Intake	0.03 ~ 0.10 mm (0.0012 ~ 0.0039 in.)	0.29 mm (0.011 in.)
Valve Seat Cutting Angle	32°, 45°, 60°	— — —
Valve Seating Surface:		
Width:		
Exhaust	0.8 ~ 1.2 mm (0.031 ~ 0.047 in.)	— — —
Intake	0.5 ~ 1.0 mm (0.020 ~ 0.039 in.)	— — —
Outside Diameter:		
Exhaust	24.7 ~ 24.9 mm (0.972 ~ 0.980 in.)	— — —
Intake	28.9 ~ 29.1 mm (1.138 ~ 1.146 in.)	— — —
Valve Spring Free Length:		
Exhaust	36.62 mm (1.442 in.)	35.2 mm (1.39 in.)
Intake	36.62 mm (1.442 in.)	35.2 mm (1.39 in.)

Specifications

Item	Standard	Service Limit
Cylinder, Pistons		
Cylinder Inside Diameter	76.990 ~ 77.006 mm (3.0311 ~ 3.0317 in.)	77.09 mm (3.035 in.)
Piston Diameter	76.974 ~ 76.984 mm (3.0305 ~ 3.0309 in.)	76.82 mm (3.024 in.)
Piston/Cylinder Clearance	0.010 ~ 0.032 mm (0.0004 ~ 0.0013 in.)	— — —
Piston Ring/Groove Clearance:		
Top	0.03 ~ 0.07 mm (0.0012 ~ 0.0028 in.)	0.17 mm (0.0067 in.)
Second	0.02 ~ 0.06 mm (0.0008 ~ 0.0024 in.)	0.16 mm (0.0063 in.)
Piston Ring Groove Width:		
Top	0.82 ~ 0.84 mm (0.0323 ~ 0.0331 in.)	0.92 mm (0.0362 in.)
Second	0.81 ~ 0.83 mm (0.0319 ~ 0.0327 in.)	0.91 mm (0.0358 in.)
Piston Ring Thickness:		
Top	0.77 ~ 0.79 mm (0.0303 ~ 0.0311 in.)	0.70 mm (0.028 in.)
Second	0.77 ~ 0.79 mm (0.0303 ~ 0.0311 in.)	0.70 mm (0.028 in.)
Piston Ring End Gap:		
Top	0.20 ~ 0.30 mm (0.0079 ~ 0.0118 in.)	0.6 mm (0.024 in.)
Second	0.38 ~ 0.48 mm (0.0150 ~ 0.0189 in.)	0.8 mm (0.031 in.)

5-10 ENGINE TOP END

Special Tools and Sealant

Compression Gauge, 20 kgf/cm²:
57001-221

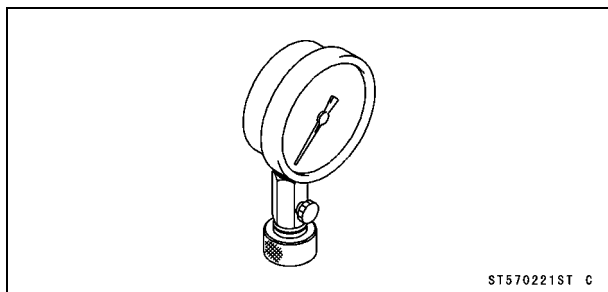

Valve Seat Cutter, 32° - ϕ 28:
57001-1119

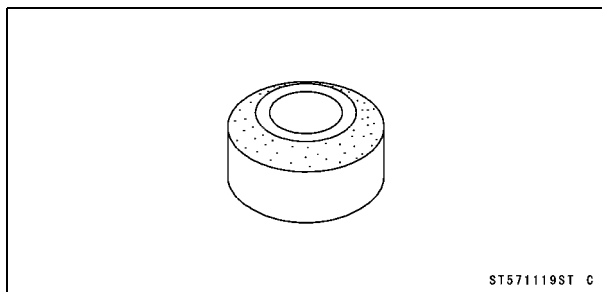

Valve Spring Compressor Assembly:
57001-241

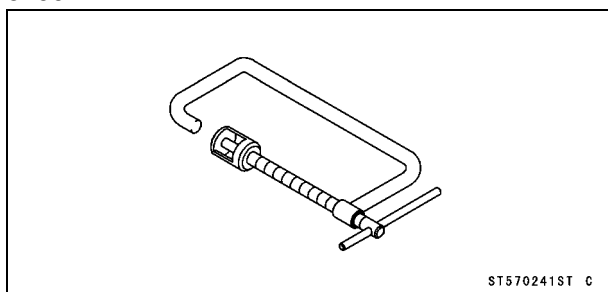

Valve Seat Cutter Holder Bar:
57001-1128

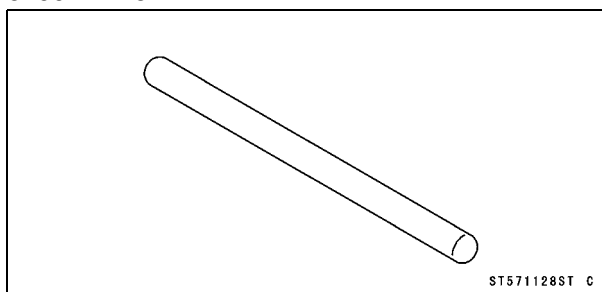

Piston Pin Puller Assembly:
57001-910

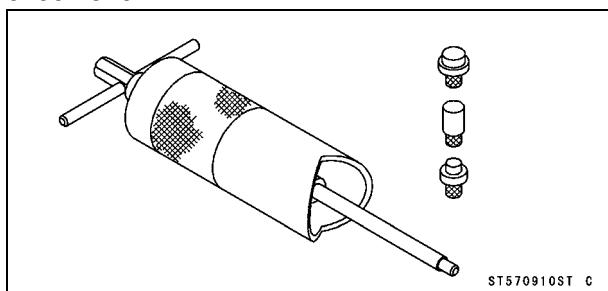

Valve Seat Cutter, 32° - ϕ 33:
57001-1199

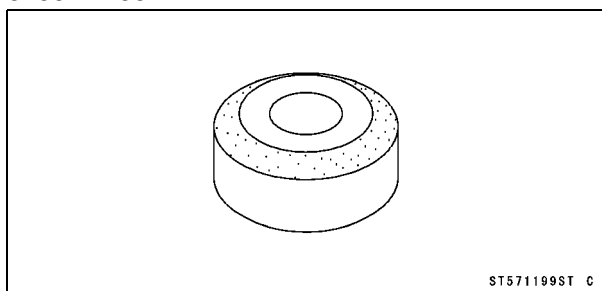

Valve Seat Cutter, 45° - ϕ 27.5:
57001-1114

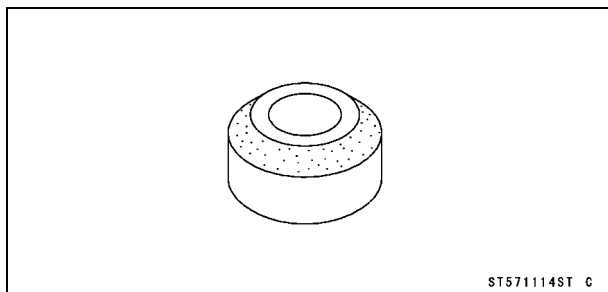

Valve Seat Cutter Holder, ϕ 4.5:
57001-1330

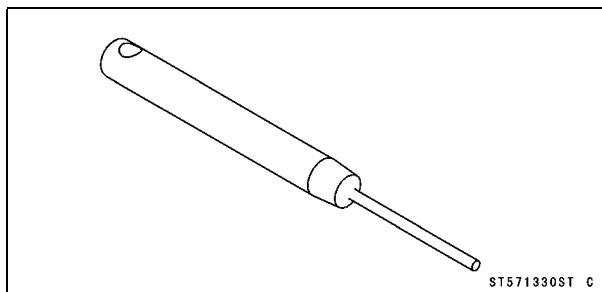

Valve Seat Cutter, 45° - ϕ 32:
57001-1115

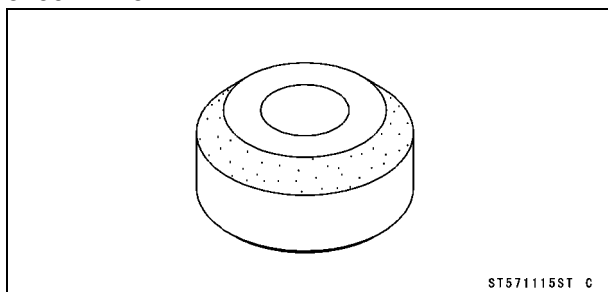

Valve Guide Arbor, ϕ 4.5:
57001-1331

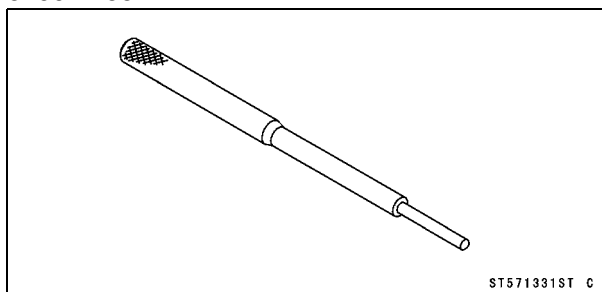

Special Tools and Sealant

Valve Guide Reamer, $\phi 4.5$:
57001-1333

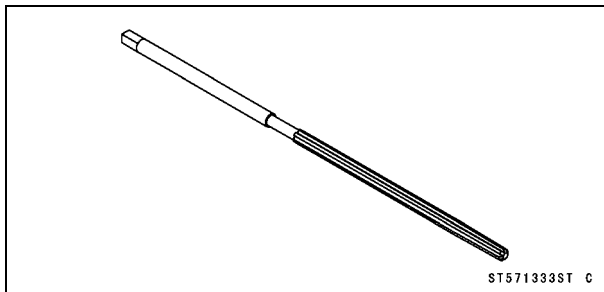

ST571333ST C

Valve Spring Compressor Adapter, $\phi 24$:
57001-1586

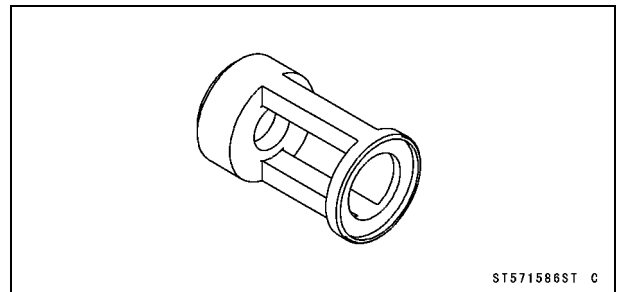

ST571586ST C

Valve Seat Cutter, 60° - $\phi 33$:
57001-1334

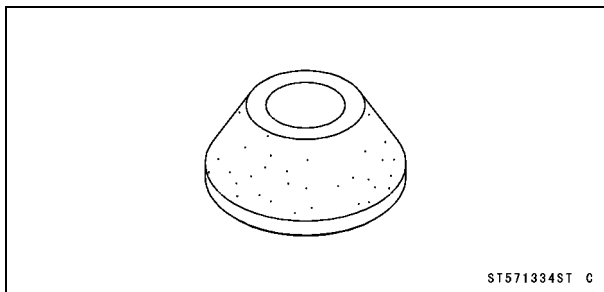

ST571334ST C

Compression Gauge Adapter, M10 x 1.0:
57001-1601

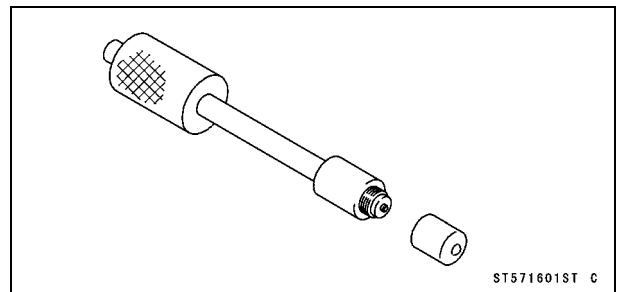

ST571601ST C

Valve Seat Cutter, 60° - $\phi 27$:
57001-1409

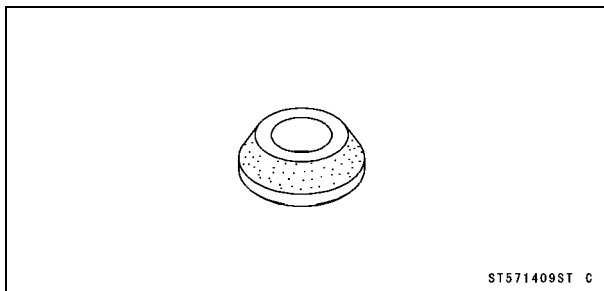

ST571409ST C

L-Shape Hose:
57001-1606

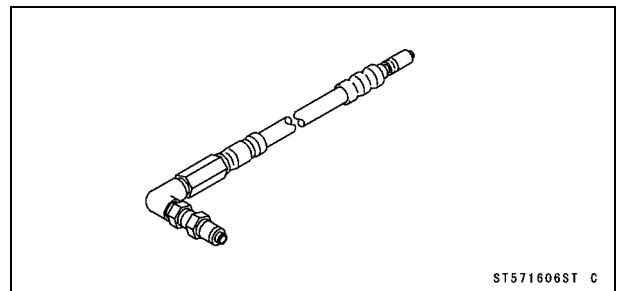

ST571606ST C

Engine Mount Nut Wrench:
57001-1450

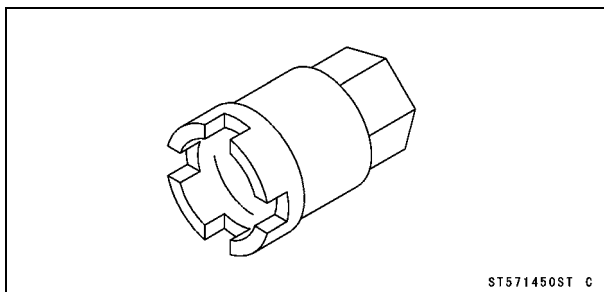

ST571450ST C

Washer:
57001-1612

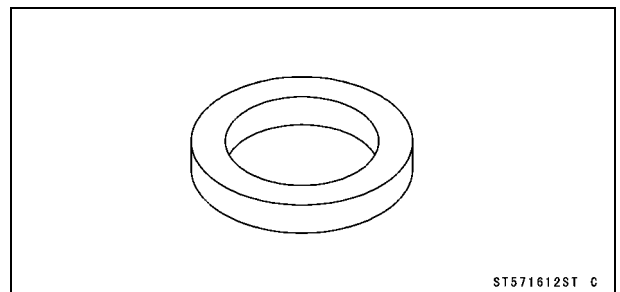

ST571612ST C

Valve Guide Driver:
57001-1564

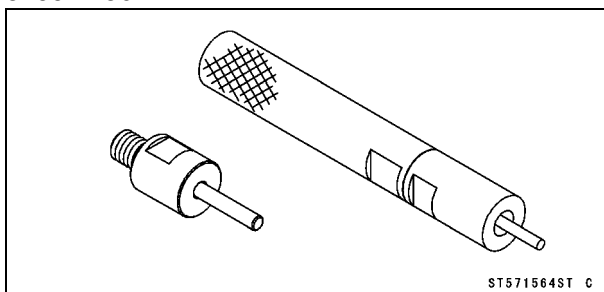

ST571564ST C

Liquid Gasket, TB1216B:
92104-1064

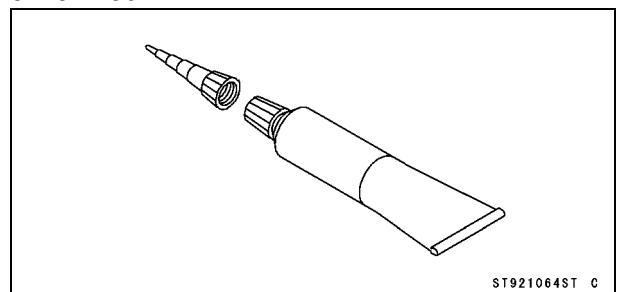

ST921064ST C

5-12 ENGINE TOP END

Clean Air System

Air Suction Valve Removal

- Remove:
 - Lower Fairing (see Lower Fairing Removal in the Frame chapter)
 - Air Switching Valve (see Air Switching Valve Removal)
 - Stick Coil Connector (see Stick Coil Removal in the Electrical System chapter)
 - Connector [A] (from Bracket [B] at Left Side)
 - Air Suction Valve Cover Bolts [C] and Bracket
 - Air Suction Valve Covers [D] (Both Sides)

- Remove the air suction valves [A] on both sides.

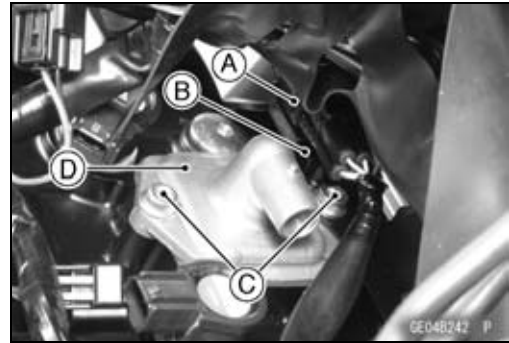

Air Suction Valve Installation

- Install the air suction valve so that opening [A] of the reed faces the front and downward.

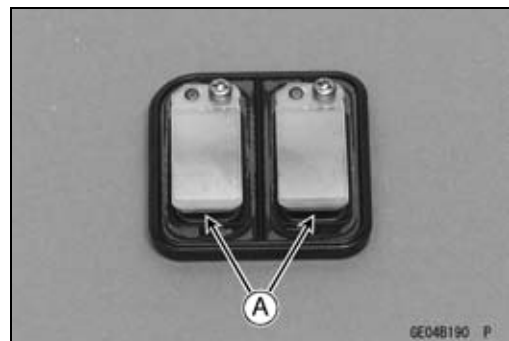

- Install the bracket [A] as shown in the figure.
 - Apply a non-permanent locking agent to the threads of the air suction valve cover bolts [B], and tighten them.
- Torque - Air Suction Valve Cover Bolts: 9.8 N·m (1.0 kgf·m, 87 in·lb)**

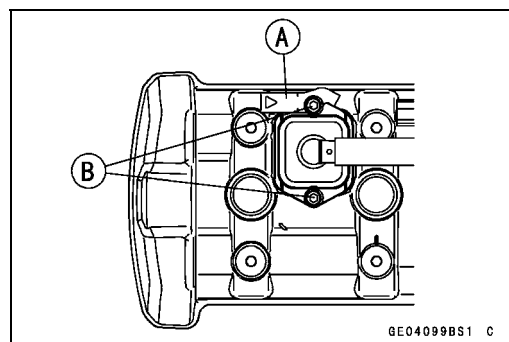

Clean Air System

Air Suction Valve Inspection

- Remove the air suction valve (see Air Suction Valve Removal).
- Visually inspect the reeds [A] for cracks, folds, warps, heat damage or other damage.
- ★ If there is any doubt as to the condition of the reeds, replace the air suction valve as an assembly.
- Check the reed contact areas [B] of the valve holder for grooves, scratches, any signs of separation from the holder or heat damage.
- ★ If there is any doubt as to the condition of the reed contact areas, replace the air suction valve as an assembly.
- ★ If any carbon or other foreign particles have accumulated between the reed and the reed contact area, wash the valve assembly clean with a high-flash point solvent.

NOTICE

Do not scrape off the deposits with a scraper as this could damage the rubber, requiring replacement of the suction valve assembly.

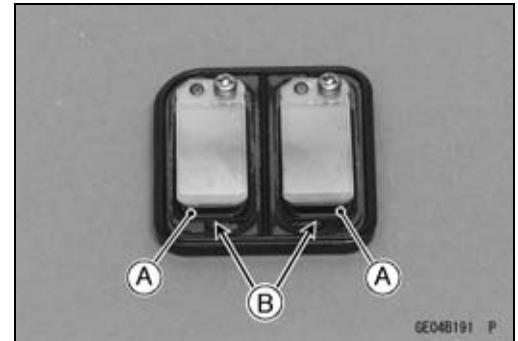

Air Switching Valve Removal

NOTICE

Never drop the air switching valve especially on a hard surface. Such a shock to the air switching valve can damaged it.

- Remove the stick coils (see Stick Coil Removal in the Electrical System chapter).
- Disconnect the connector [A].
- Clear the harness [B] from the clamp [C].
- Separate the hoses [D] from the air switching valve [E] to remove the air switching valve.

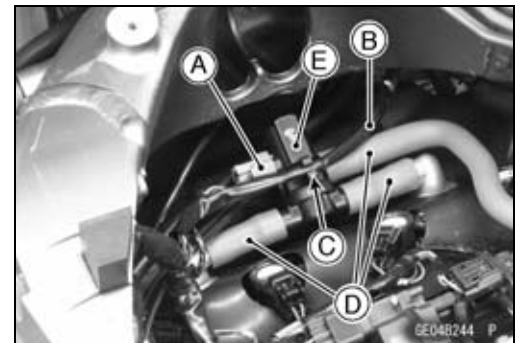

Air Switching Valve Installation

- Install the air switching valve [A] as shown in the figure.
 - [B] Viewed Left Side
 - [C] About 40°

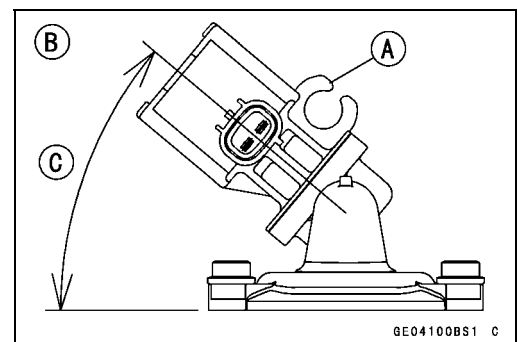

Air Switching Valve Operation Test

- Refer to the Air Suction System Damage Inspection in the Periodic Maintenance chapter.

Air Switching Valve Unit Test

- Refer to the Air Switching Valve Unit Test in the Electrical System chapter.

5-14 ENGINE TOP END

Clean Air System

Clean Air System Hose Inspection

- Be certain that all the hoses are routed without being flattened or kinked, and are connected correctly to the air cleaner housing, air switching valve and air suction valve covers.
- ★ If they are not, correct them. Replace them if they are damaged.

Cylinder Head Cover

Cylinder Head Cover Removal

- Remove:
 - Lower Fairing (see Lower Fairing Removal in the Frame chapter)
 - Air Cleaner Housing (see Air Cleaner Housing Removal in the Fuel System (DFI) chapter)
- Drain the coolant (see Coolant Change in the Periodic Maintenance chapter).
- Remove:
 - Radiator Cap Mounting Bolt [A]
 - Clamp [B]
 - Water Hose [C]
- Remove:
 - Bolts [A]
 - Quick Rivets [B]
 - Brackets [C]
 - Right Side [D]
 - Left Side [E]
- Remove:
 - Air Switching Valve (see Air Switching Valve Removal)
 - Stick Coils (see Stick Coil Removal in the Electrical System chapter)
 - Quick Rivets [A]
- Pull up the rubber cover [B] forward.

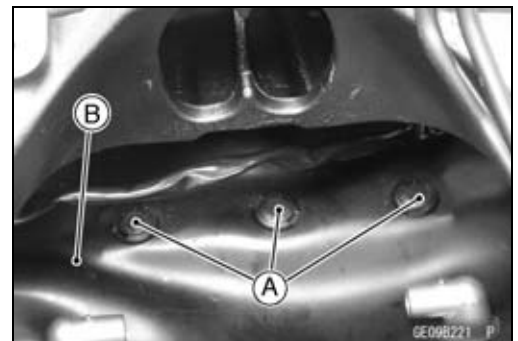
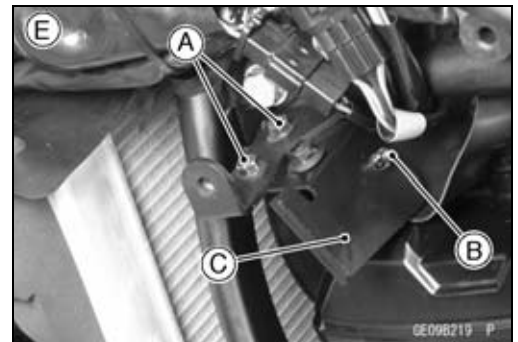
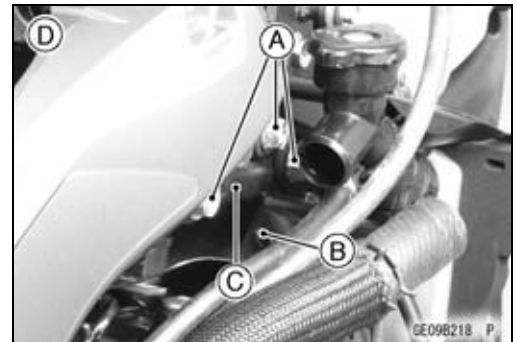
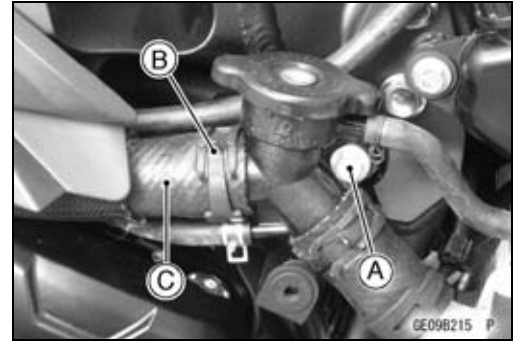

5-16 ENGINE TOP END

Cylinder Head Cover

- Remove:
Air Suction Valves [A] (see Air Suction Valve Removal)
Hot Windshield [B] and Air Suction Valve Cover Bracket [C]

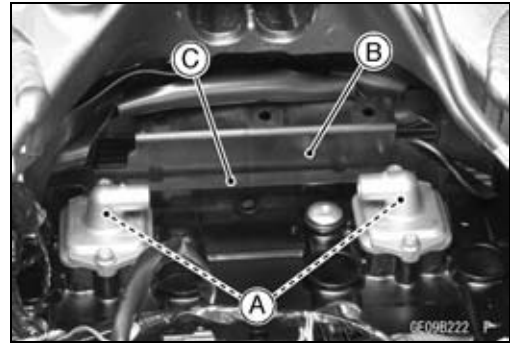

- Remove:
Cylinder Head Cover Bolts [A]
Cylinder Head Cover

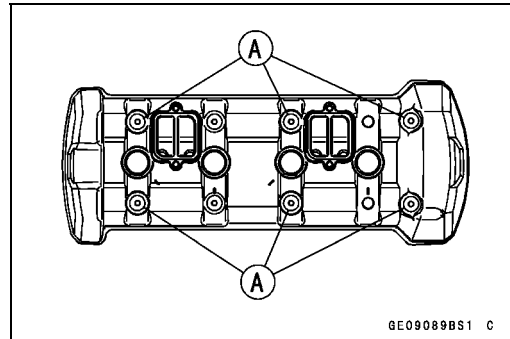

Cylinder Head Cover Installation

- Install:
Dowel Pins [A]
Plug Hole Gaskets [B]

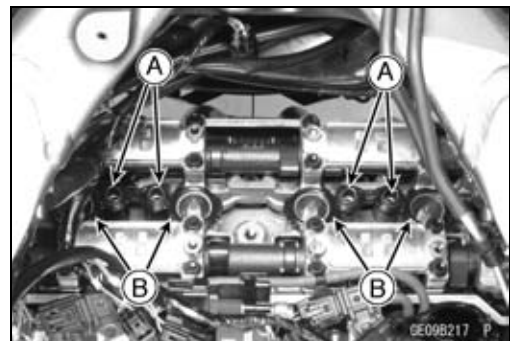

- Apply liquid gasket [A] to the cylinder head as shown.
- Using a high-flash point solvent, clean off any oil or dirt that may be on the liquid gasket coating area. Dry them with a clean cloth.

Sealant - Liquid Gasket, TB1216B: 92104-1064

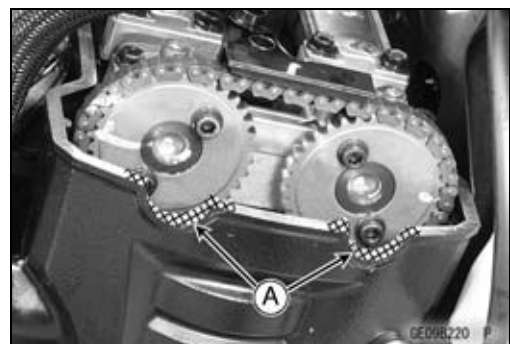
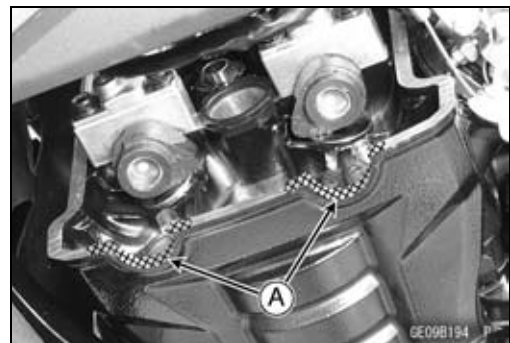

Cylinder Head Cover

- Replace the head cover gasket [A] with a new one.
- Install the gasket to the cylinder head cover [B].

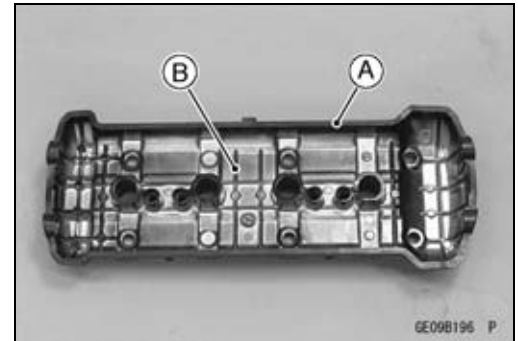

- While pulling up the water hose on radiator cap, install the cylinder head cover from the right side.
- Apply soap and water solution or rubber lubricant to the both surface of the washers.
- Install the washers with the metal side [A] faces upward.



- Tighten the cover bolts following the specified tightening sequence.

Torque - Cylinder Head Cover Bolts: 9.8 N-m (1.0 kgf-m, 87 in-lb)

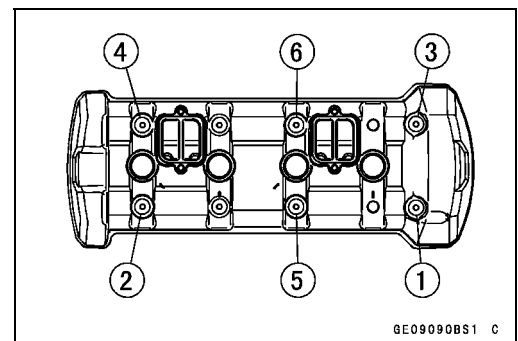

- Install:
Air Suction Valves [A] (see Air Suction Valve Installation)
Hot Windshield [B] and Air Suction Valve Cover Bracket [C]

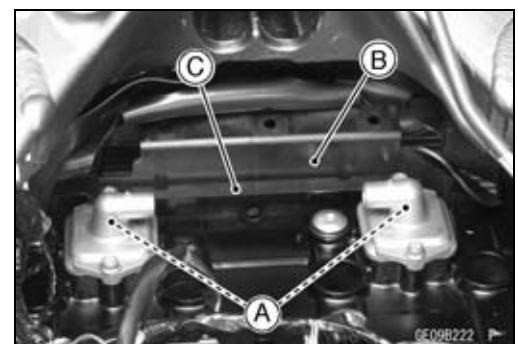

- ★ If the air suction valve cover bracket [A] and hot windshield [B] has been disassembled, assemble them and note the following.

- Tighten the hot windshield mounting bolts [C].

Torque - Hot Windshield Mounting Bolts: 9.8 N-m (1.0 kgf-m, 87 in-lb)

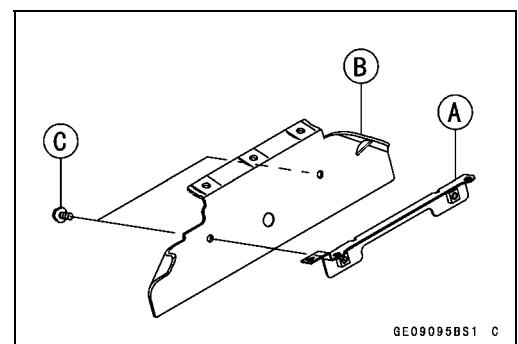

5-18 ENGINE TOP END

Cylinder Head Cover

- Install the quick rivets [A].
- Position the rubber cover [B] on the cylinder head cover as shown.

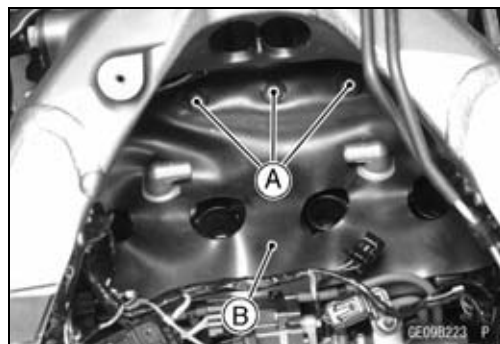

- Install the removed parts (see appropriate chapters).

Camshaft Chain Tensioner

Camshaft Chain Tensioner Removal

NOTICE

This is a non-return type camshaft chain tensioner. The push rod does not return to its original position once it moves out to take up camshaft chain slack. Observe all the rules listed below.

When removing the tensioner, do not take out the mounting bolts only halfway. Retightening the mounting bolts from this position could damage the tensioner and the camshaft chain. Once the bolts are loosened, the tensioner must be removed and reset as described in "Camshaft Chain Tensioner Installation".

Do not turn over the crankshaft while the tensioner is removed. This could upset the camshaft chain timing, and damage the valves.

- Remove:
 - Right Lower Fairing (see Lower Fairing Removal in the Frame chapter)
 - Cap Bolt [A]
 - Washer [B]
 - Spring [C]
 - Rod [D]
 - Mounting Bolts [E]
 - Camshaft Chain Tensioner [F]
 - Bracket [G]

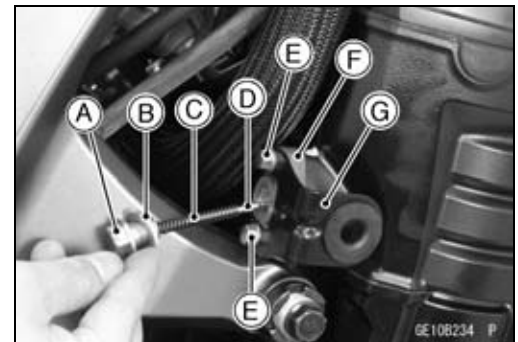

Camshaft Chain Tensioner Installation

- Replace the O-ring [A] with a new one.
- Apply grease to the new O-ring.
- Release the stopper [B] and push the push rod [C] into the tensioner body [D].
- Install the tensioner body so that the stopper faces upward.

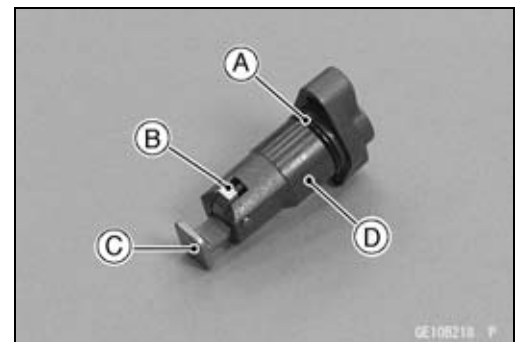

- Install the Bracket [A].
- Tighten:
 - Torque - Camshaft Chain Tensioner Mounting Bolts [B]: 11 N·m (1.1 kgf·m, 97 in·lb)**
- Install the rod, spring and washer.
- Tighten:
 - Torque - Camshaft Chain Tensioner Cap Bolt [C]: 20 N·m (2.0 kgf·m, 15 ft·lb)**
- Turn the crankshaft 2 turns clockwise to allow the tensioner to expand and recheck the camshaft chain timing.

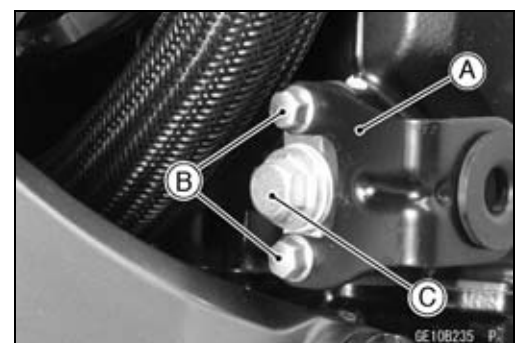

5-20 ENGINE TOP END

Camshaft, Camshaft Chain

Camshaft Removal

- Remove:
 - Cylinder Head Cover (see Cylinder Head Cover Removal)
 - Crankshaft Sensor Cover (see Crankshaft Sensor Removal in the Electrical System chapter)
- Turn the crankshaft clockwise, align the #1, 4 mark on the timing rotor with the crankcase timing mark.
 - TDC mark [A] for #1, 4 Pistons
 - Timing Mark (Crankcase Halves Mating Surface) [B]
- Remove the camshaft chain tensioner (see Camshaft Chain Tensioner Removal).
- Loosen the upper chain guide bolts and camshaft cap bolts as shown sequence [1 ~ 20] in the figure, and remove them.
- Remove:
 - Upper Chain Guide [A]
 - Camshaft Caps [B]
 - Camshafts [C]
- Stuff a clean cloth into the chain tunnel to keep any parts from dropping into the crankcase.

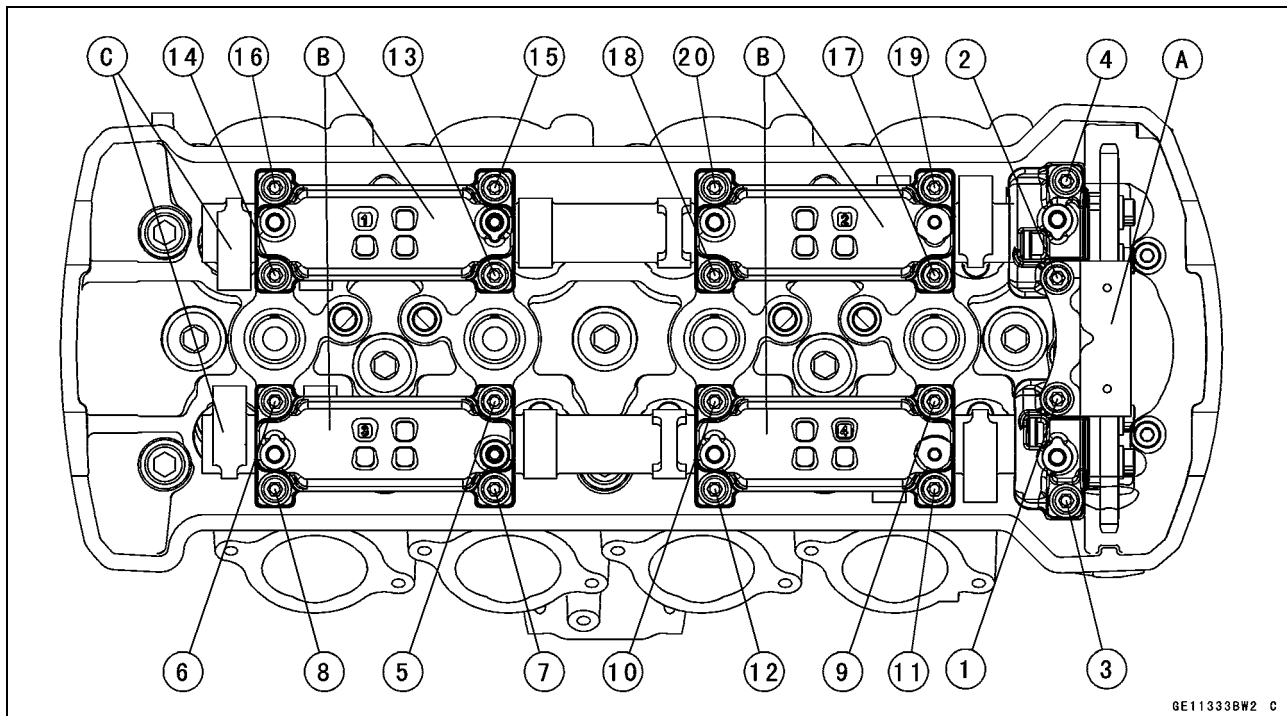
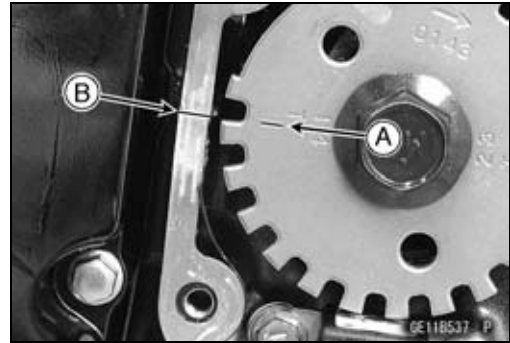

GE113338W2 C

- Remove:
 - Camshaft Sprocket Mounting Bolts [A]
 - Camshaft Sprockets [B]

NOTICE

The crankshaft may be turned while the camshafts are removed. Always pull the chain taut while turning the crankshaft. This avoids kinking the chain on the lower (crankshaft) sprocket. A kinked chain could damage both the chain and the sprocket.

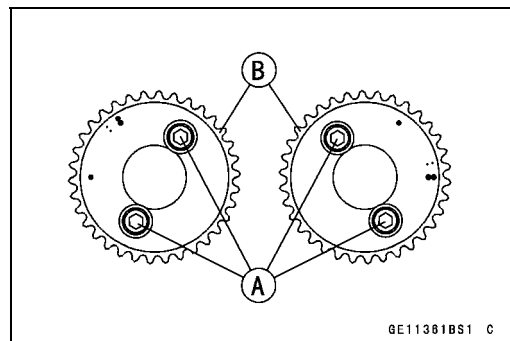

GE11381BS1 C

Camshaft, Camshaft Chain

Camshaft Installation

- Be sure to install the following parts.
 - Plug Hole Gaskets [A]
 - Dowel Pins [B]

NOTE

○ The exhaust camshaft has a 8943 EX mark [A] and the intake camshaft has a 8943 IN mark [B]. Be careful not to mix up these shafts.

- Install the camshaft sprockets so that position the timing marks [A] outside.
- The intake camshaft sprocket and exhaust camshaft sprocket are identical.
- Apply a non-permanent locking agent to the threads of the camshaft sprocket bolts and tighten them.

Torque - Camshaft Sprocket Bolts: 15 N·m (1.5 kgf·m, 11 ft·lb)

- Apply molybdenum disulfide oil solution to all cam parts and journals.
- Using a wrench on the timing rotor bolt [A], turn the crankshaft clockwise until the line [B] (TDC mark for #1,4 pistons) on the timing rotor is aligned with the timing mark [C] (Crankcase Halves Mating Surface).

NOTICE

The crankshaft may be turned while the camshafts are removed. Always pull the chain taut while turning the crankshaft. This avoids kinking the chain on the lower (crankshaft) sprocket. A kinked chain could damage both the chain and the sprocket.

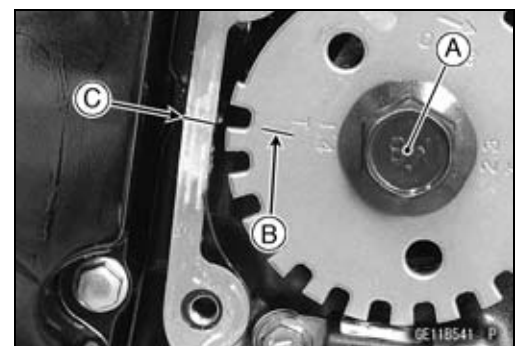
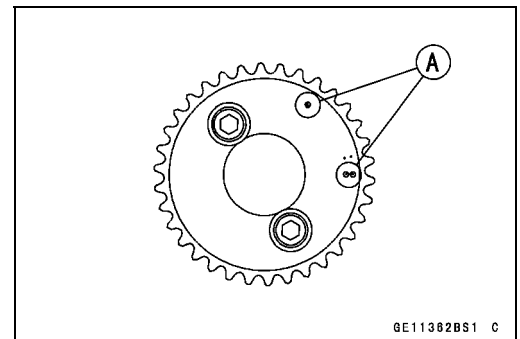
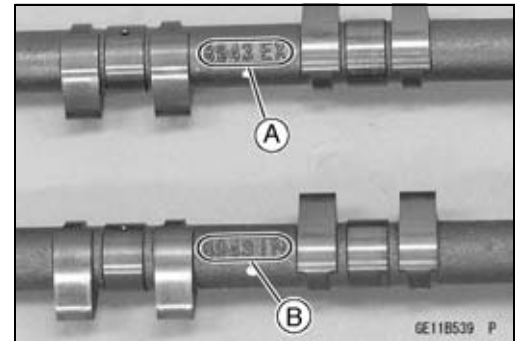
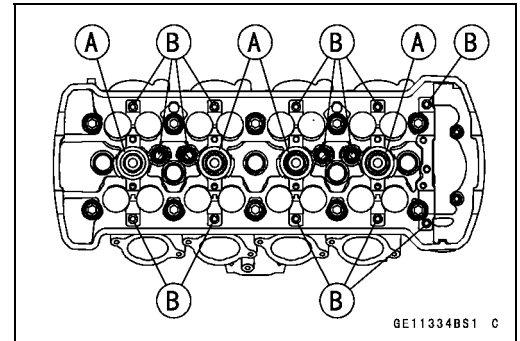

5-22 ENGINE TOP END

Camshaft, Camshaft Chain

- Pull the tension side (exhaust side) [A] of the chain taut to install the chain.
- Engage the camshaft chain with the sprockets so that timing marks on the sprockets are positioned as shown in the figure.
- The timing marks must be aligned with the cylinder head upper surface [B].
 - EX mark [C]
 - IN mark [D]
 - #1 pin [E]
 - #2 pin [F]
 - #29 pin [G]
 - #30 pin [H]

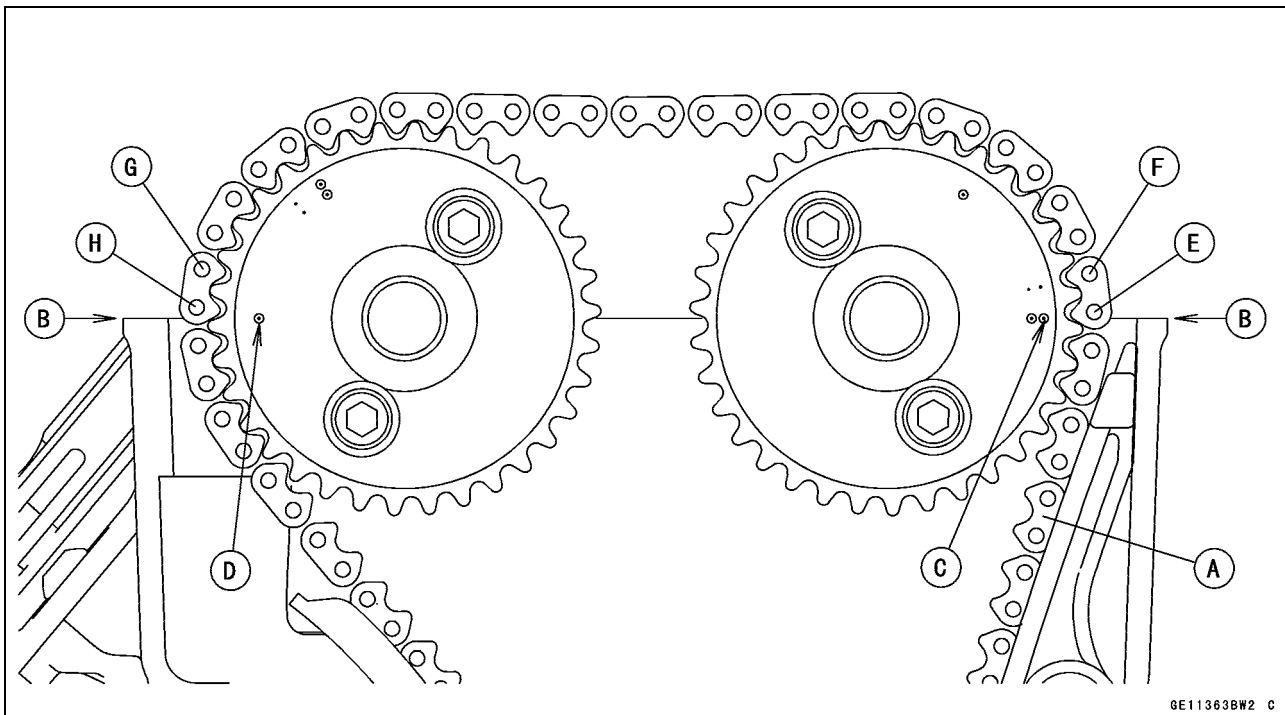

Camshaft, Camshaft Chain

- Before installing the camshaft caps and upper chain guide, install the camshaft chain tensioner body temporarily (see Camshaft Chain Tensioner Installation).
- Install the camshaft caps and upper camshaft chain guide [A] as shown in the figure.
Identification No. 1 ~ 4 (Camshaft Cap) [B]
- First tighten the all camshaft cap bolts and upper camshaft chain guide bolts evenly to seat the camshaft in place, then tighten all bolts following the specified tightening sequence.

Torque - Camshaft Cap Bolts [1 ~ 18]: 12 N·m (1.2 kgf·m, 106 in·lb)

Upper Camshaft Chain Guide Bolts [19, 20]: 12 N·m (1.2 kgf·m, 106 in·lb)

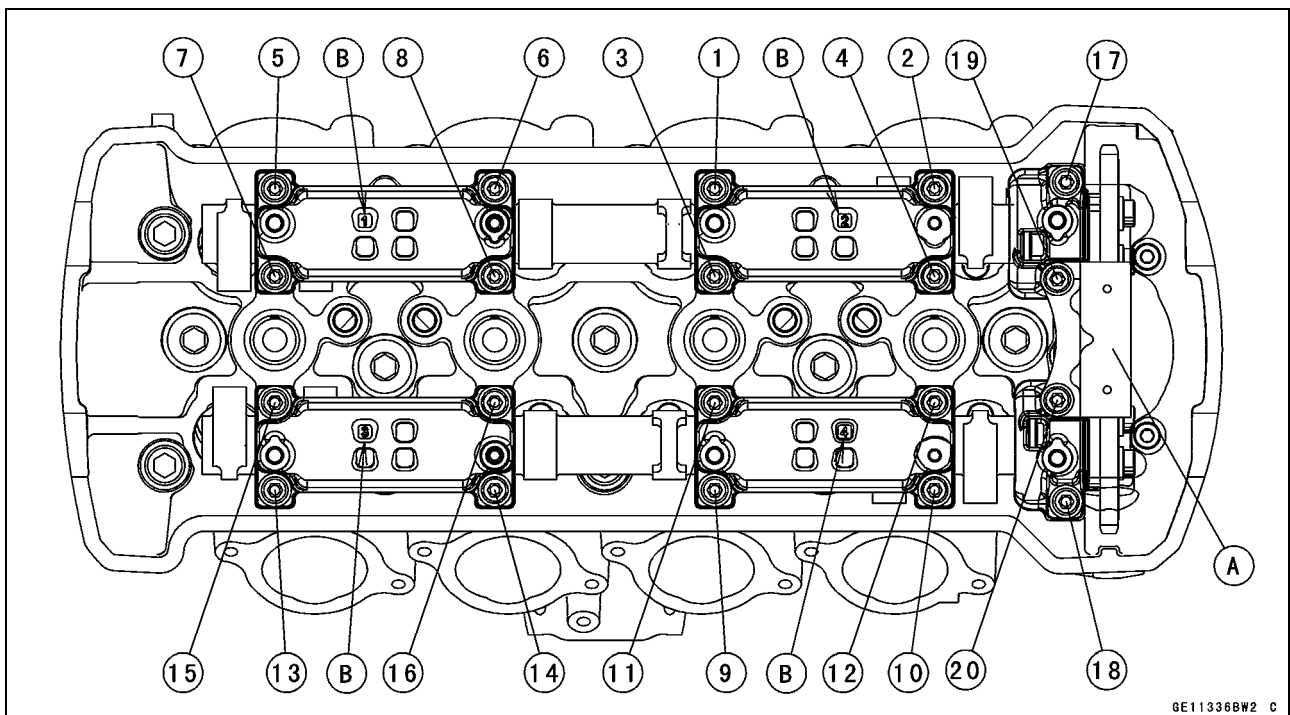

- Install the camshaft chain tensioner (see Camshaft Chain Tensioner Installation).
- Turn the crankshaft 2 turns clockwise to allow the tensioner to expand and recheck the camshaft chain timing.
- Install the cylinder head cover (see Cylinder Head Cover Installation).

5-24 ENGINE TOP END

Camshaft, Camshaft Chain

Camshaft, Camshaft Cap Wear Inspection

- Remove:
 - Upper Chain Guide (see Camshaft Removal)
 - Camshaft Caps (see Camshaft Removal)
- Cut strips of plastigage (press gauge) to journal width. Place a strip on each journal parallel to the camshaft installed in the correct position.
- Measure each clearance between the camshaft journal and the camshaft cap using plastigage [A].
- Tighten the camshaft cap bolts (see Camshaft Installation).



NOTE

○ Do not turn the camshaft when the plastigage is between the journal and camshaft cap.

Camshaft Journal, Camshaft Cap Clearance

Standard: 0.038 ~ 0.081 mm (0.0015 ~ 0.0032 in.)

Service Limit: 0.17 mm (0.0067 in.)

- ★ If any clearance exceeds the service limit, measure the diameter of each camshaft journal with a micrometer.

Camshaft Journal Diameter

Standard: 23.940 ~ 23.962 mm (0.9425 ~ 0.9434 in.)

Service Limit: 23.91 mm (0.9413 in.)

- ★ If the camshaft journal diameter is less than the service limit, replace the camshaft with a new one and measure the clearance again.
- ★ If the clearance still remains out of the limit, replace the cylinder head unit.

Camshaft Runout Inspection

- Remove the camshafts (see Camshaft Removal).
- Set the camshaft in a camshaft alignment jig or on V blocks.
- Measure runout with a dial gauge at the specified place as shown in the figure.
- ★ If the runout exceeds the service limit, replace the shaft.

Camshaft Runout

Standard: TIR 0.02 mm (0.0008 in.) or less

Service Limit: TIR 0.1 mm (0.004 in.)

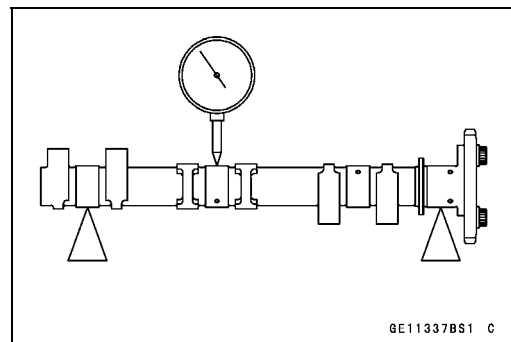

Camshaft, Camshaft Chain

Cam Wear Inspection

- Remove the camshafts (see Camshaft Removal).
- Measure the height [A] of each cam with a micrometer.
- ★ If the cams are worn down past the service limit, replace the camshaft.

Cam Height

Standard:

Exhaust 33.743 ~ 33.857 mm (1.3285 ~ 1.3330 in.)

Intake 34.743 ~ 34.857 mm (1.3678 ~ 1.3723 in.)

Service Limit:

Exhaust 33.64 mm (1.324 in.)

Intake 34.64 mm (1.364 in.)

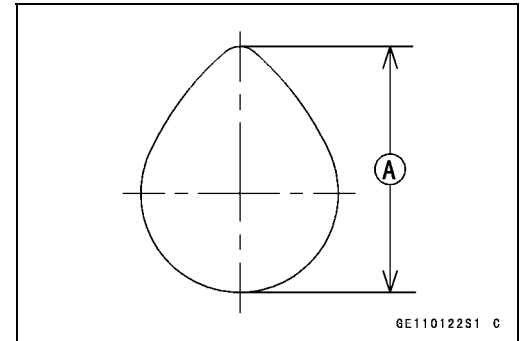

Camshaft Chain Removal

- Split the crankcase (see Crankcase Splitting in the Crankshaft/Transmission chapter).
- Remove the camshaft chain [A] from the crankshaft sprocket.

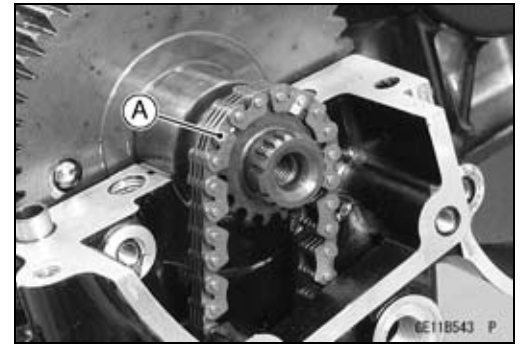

5-26 ENGINE TOP END

Cylinder Head

Cylinder Compression Measurement

NOTE

○ Use the battery which is fully charged.

- Warm up the engine thoroughly.
- Stop the engine.
- Remove:
 - Stick Coils (see Stick Coil Removal in the Electrical System chapter)
 - Spark Plugs (see Spark Plug Replacement in the Periodic Maintenance chapter)
- Attach the compression gauge [A] and adapter [B] firmly into the spark plug hole.
- Using the starter motor, turn the engine over with the throttle fully open until the compression gauge stops rising; the compression is the highest reading obtainable.

Special Tools - Compression Gauge, 20 kgf/cm²: 57001-221
Compression Gauge Adapter, M10 × 1.0: 57001-1601
L-Shape Hose: 57001-1606

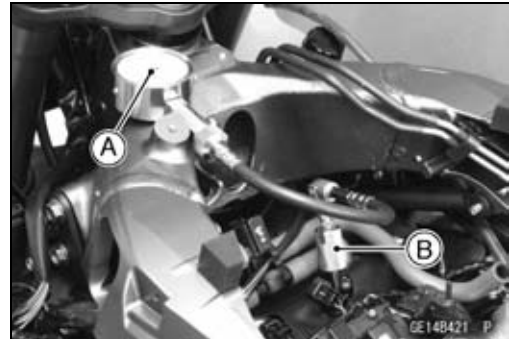

Cylinder Compression

Usable Range: 966 ~ 1 478 kPa (9.9 ~ 15.1 kgf/cm², 140 ~ 214 psi) at 280 r/min (rpm)

- Repeat the measurement for the other cylinders.
- Install the spark plugs.

Torque - Spark Plugs: 13 N·m (1.3 kgf·m, 115 in·lb)

○ The following table should be consulted if the obtainable compression reading is not within the usable range.

Problem	Diagnosis	Remedy (Action)
Cylinder compression is higher than usable range	Carbon accumulation on piston and in combustion chamber possibly due to damaged valve stem oil seal and/or damaged piston oil rings (This may be indicated by white exhaust smoke).	Remove the carbon deposits and replace damaged parts if necessary.
	Incorrect cylinder head gasket thickness	Replace the gasket with a standard part.
Cylinder compression is lower than usable range	Gas leakage around cylinder head	Replace damaged check gasket and cylinder head warp.
	Bad condition of valve seating	Repair if necessary.
	Incorrect valve clearance	Adjust the valve clearance.
	Incorrect piston/cylinder clearance	Replace the piston and/or cylinder.
	Piston seizure	Inspect the cylinder and replace/repair the cylinder and/or piston as necessary.
	Bad condition of piston ring and/or piston ring grooves.	Replace the piston and/or the piston rings.

Cylinder Head

Cylinder Head Removal

- Remove:
 - Coolant (Drain, see Coolant Change in the Periodic Maintenance chapter)
 - Camshafts (see Camshaft Removal)
 - Throttle Body Assy (see Throttle Body Assy Removal in the Fuel System (DFI) chapter)
 - Exhaust Pipe (see Exhaust Pipe Removal)

- Disconnect the water temperature sensor connector [A].
- Remove:
 - Clamps [B]
 - Water Hoses [C]

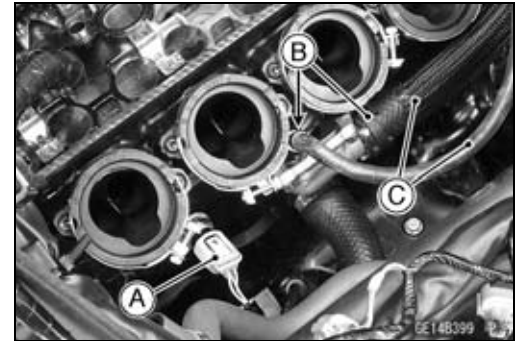

- Remove:
 - Timing Rotor (see Timing Rotor Removal in the Electrical System chapter)
 - Front Camshaft Chain Guide Bolts [A]
 - Front Camshaft Chain Guide [B]
 - Rear Camshaft Chain Guide Bolt [C]
 - Rear Camshaft Chain Guide [D]

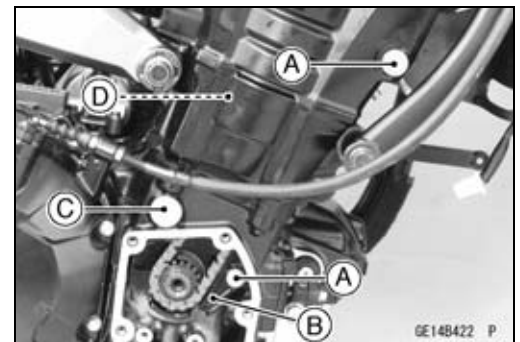

- Loosen:
 - Lower Engine Bracket Bolts (Both Sides) [A]
 - Upper Engine Mounting Bolts (Left)

- Remove:
 - Upper Engine Mounting Bolts (Right) [B]

- Loosen:
 - Upper Adjusting Collar Locknut [C]

Special Tool - Engine Mount Nut Wrench: 57001-1450

- Loosen:
 - Upper Adjusting Collar [D]

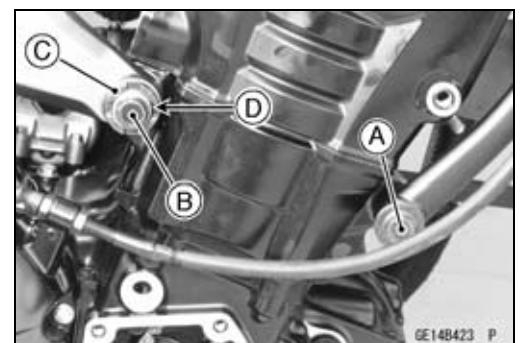

- Remove the M6 cylinder head bolts [A].
- Loosen the M10 cylinder head bolts as shown sequence [1 ~ 10] in the figure, and remove them with washers.
- Remove the cylinder head.

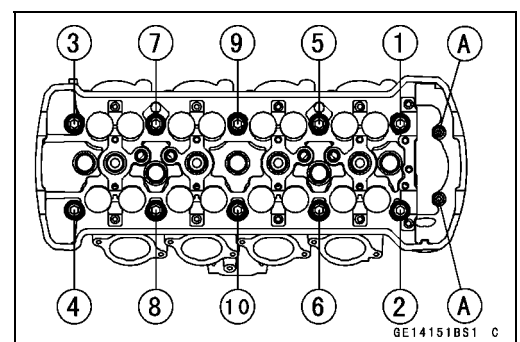

Cylinder Head Installation

NOTE

- The camshaft cap is machined with the cylinder head, so if a new cylinder head is installed, use the cap that is supplied with the new head.

5-28 ENGINE TOP END

Cylinder Head

- Replace the cylinder head gasket [A] with a new one.
- Install the dowel pins [B] and cylinder head gasket.

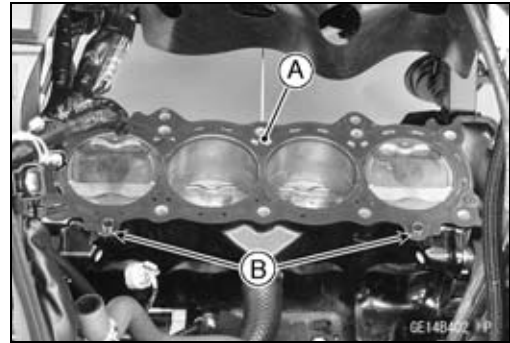

- Replace the cylinder head bolt washers [A] with new ones.
- Apply molybdenum disulfide oil solution to both sides [B] of the cylinder head bolt washers and threads [C] of the bolts.

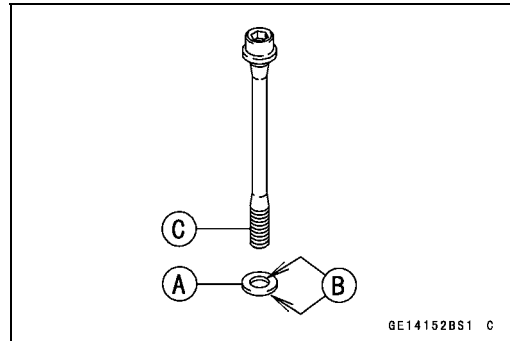

- Tighten the M10 cylinder head bolts following the tightening sequence [1 ~ 10].

Torque - Cylinder Head Bolts (M10):

First 20 N·m (2.0 kgf·m, 15 ft·lb)

Final 54 N·m (5.5 kgf·m, 40 ft·lb)

- Tighten:

Torque - Cylinder Head Bolts (M6) [A]: 12 N·m (1.2 kgf·m, 106 in·lb)

Upper Adjusting Collar: 9.8 N·m (1.0 kgf·m, 87 in·lb)

Upper Adjusting Collar Locknut: 4.9 N·m (5.0 kgf·m, 36 ft·lb)

Upper Engine Mounting Bolts: 44 N·m (4.5 kgf·m, 32 ft·lb)

Lower Engine Bracket Bolts: 59 N·m (6.0 kgf·m, 44 ft·lb)

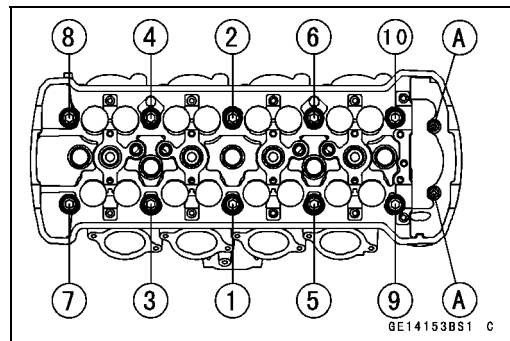

Cylinder Head

- Install:
 - Front Camshaft Chain Guide [A]
 - Rear Camshaft Chain Guide [B]
 - New O-rings [C]
 - Collar [D]
- Apply grease to the new O-ring.
- Tighten:
 - Torque - Front Camshaft Chain Guide Bolt (Upper) [E]: 25 N·m (2.5 kgf·m, 18 ft·lb)**
 - Front Camshaft Chain Guide Bolt (Lower) [F]: 12 N·m (1.2 kgf·m, 106 in·lb)**
 - Rear Camshaft Chain Guide Bolt [G]: 25 N·m (2.5 kgf·m, 18 ft·lb)**
- Install the removed parts (see appropriate chapters).

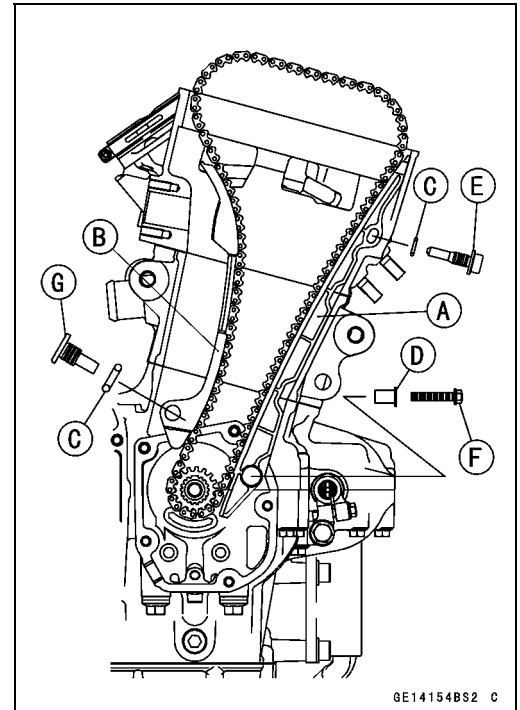

Cylinder Head Warp Inspection

- Clean the cylinder head.
- Lay a straightedge across the lower surface of the cylinder head at several positions.
- Use a thickness gauge [A] to measure the space between the straightedge [B] and the head.

Cylinder Head Warp

Standard: - - -

Service Limit: 0.05 mm (0.002 in.)

- ★ If the cylinder head is warped more than the service limit, replace it.
- ★ If the cylinder head is warped less than the service limit, repair the head by rubbing the lower surface on emery paper secured to a surface plate (first No. 200, then No. 400).

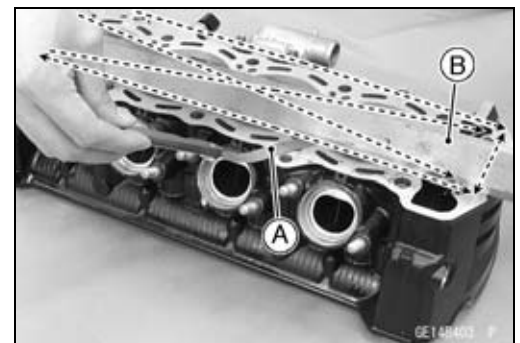

5-30 ENGINE TOP END

Valves

Valve Clearance Inspection

- Refer to the Valve Clearance Inspection in the Periodic Maintenance chapter.

Valve Clearance Adjustment

- Refer to the Valve Clearance Adjustment in the Periodic Maintenance chapter.

Valve Removal

- Remove:
 - Cylinder Head (see Cylinder Head Removal)
 - Valve Lifter and Shim
- Mark and record the valve lifter and shim locations so they can be installed in their original positions.
- Using the valve spring compressor assembly, remove the valve.

Special Tools - Valve Spring Compressor Assembly [A]:
57001-241

Valve Spring Compressor Adapter, $\phi 24$ [B]:
57001-1586

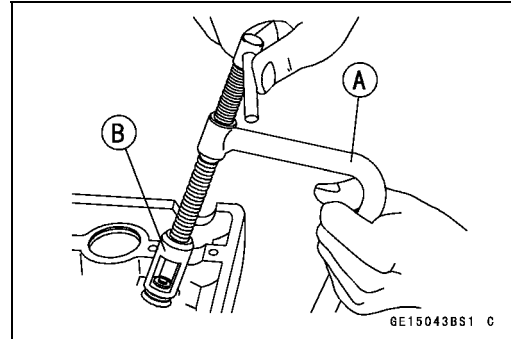

Valve Installation

- Replace the oil seal with a new one.
- Apply a thin coat of molybdenum disulfide grease to the valve stem before valve installation.
- Install the springs so that the closed coil end faces downwards.

Valve Stem [A]
Oil Seal [B]
Spring Seat [C]
Closed Coil End [D]
Valve Spring [E]
Retainer [F]
Split Keepers [G]

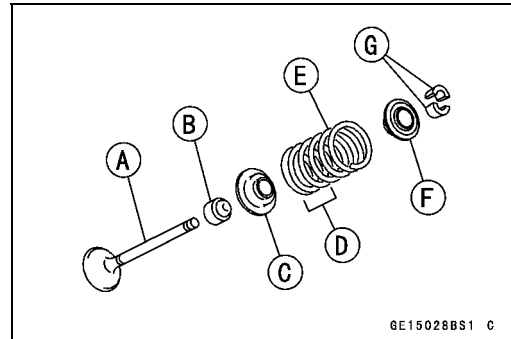

Valve Guide Removal

- Remove:
 - Valve (see Valve Removal)
 - Oil Seal
 - Spring Seat
- Heat the area around the valve guide to 120 ~ 150°C (248 ~ 302°F), and hammer lightly on the valve guide arbor [A] to remove the guide from the top of the head.

NOTICE

Do not heat the cylinder head with a torch. This will warp the cylinder head. Soak the cylinder head in oil and heat the oil.

Special Tool - Valve Guide Arbor, $\phi 4.5$: 57001-1331

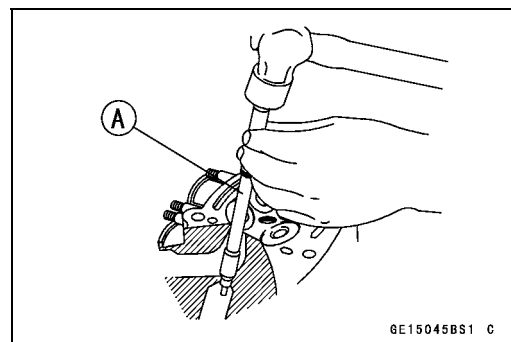

Valves

Valve Guide Installation

- Apply oil to the valve guide outer surface before installation.
- Heat the area around the valve guide hole to about 120 ~ 150°C (248 ~ 302°F).

NOTICE

Do not heat the cylinder head with a torch. This Will warp the cylinder head. Soak the cylinder head and heat the oil.

- Using the valve guide driver [A] and two washers [B], press and insert the valve guide in until the valve guide driver surface [C] touches the head surface [D].
12.8 ~ 13.0 mm (0.504 ~ 0.512 in.) [E]

Special Tools - Valve Guide Driver: 57001-1564
Washer: 57001-1612

- Ream the valve guide with valve guide reamer [A], even if the old guide is reused.

Special Tool - Valve Guide Reamer, ϕ 4.5: 57001-1333

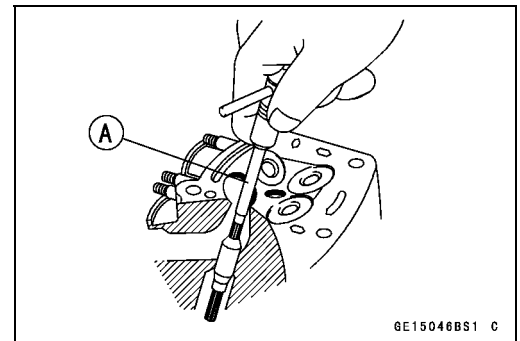
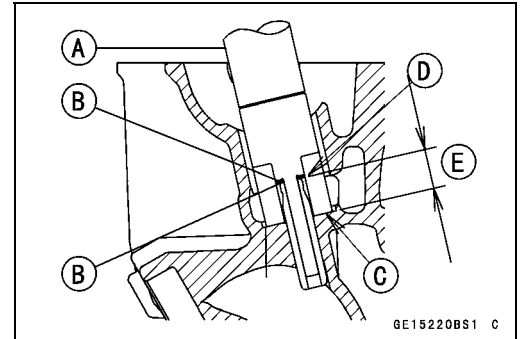

5-32 ENGINE TOP END

Valves

Valve-to-Guide Clearance Measurement (Wobble Method)

If a small bore gauge is not available, inspect the valve guide wear by measuring the valve to valve guide clearance with the wobble method as indicated below.

- Insert a new valve [A] into the guide [B] and set a dial gauge against the stem perpendicular to it as close as possible to the cylinder head mating surface.
- Move the stem back and forth [C] to measure valve/valve guide clearance.
- Repeat the measurement in a direction at a right angle to the first.
- ★ If the reading exceeds the service limit, replace the guide.

NOTE

○ The reading is not actual valve/valve guide clearance because the measuring point is above the guide.

Valve/Valve Guide Clearance (Wobble Method)

Standard:

Exhaust	0.08 ~ 0.14 mm (0.0031 ~ 0.0055 in.)
Intake	0.03 ~ 0.10 mm (0.0012 ~ 0.0039 in.)

Service Limit:

Exhaust	0.31 mm (0.012 in.)
Intake	0.29 mm (0.011 in.)

Valve Seat Inspection

- Remove the valve (see Valve Removal).
- Check the valve seating surface [A] between the valve [B] and valve seat [C].
- Measure the outside diameter [D] of the seating pattern on the valve seat.
- ★ If the outside diameter is too large or too small, repair the seat (see Seat Repair).

Valve Seating Surface Outside Diameter

Standard:

Exhaust	24.7 ~ 24.9 mm (0.972 ~ 0.980 in.)
Intake	28.9 ~ 29.1 mm (1.138 ~ 1.146 in.)

○ Measure the seat width [E] of the portion where there is no build-up carbon (white portion) of the valve seat with a vernier caliper.

Good [F]

- ★ If the width is too wide [G], too narrow [H] or uneven [J], repair the seat (see Valve Seat Repair).

Valve Seating Surface Width

Standard:

Exhaust	0.8 ~ 1.2 mm (0.031 ~ 0.047 in.)
Intake	0.5 ~ 1.0 mm (0.020 ~ 0.039 in.)

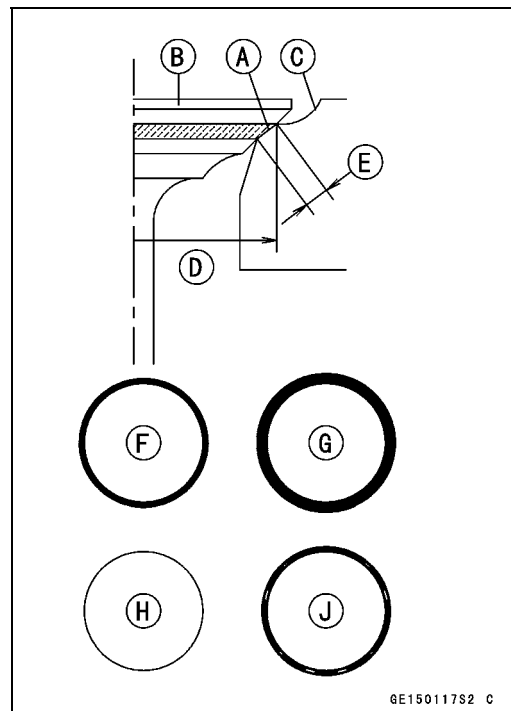
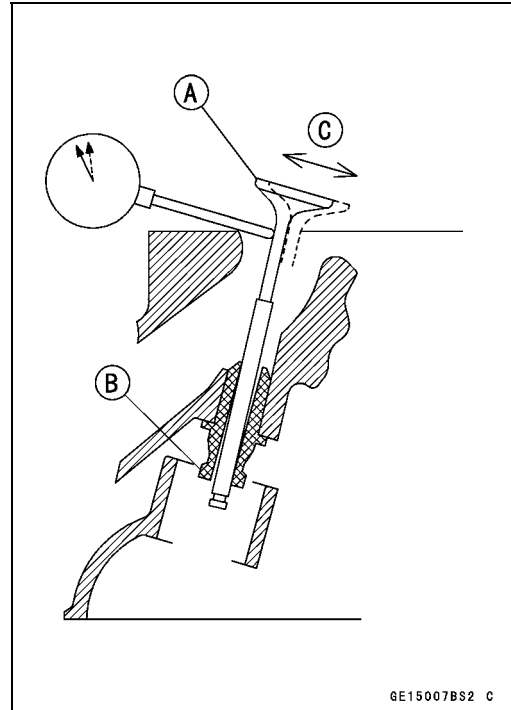

Valves

Valve Seat Repair

- Repair the valve seat with the valve seat cutters [A].

Special Tools - Valve Seat Cutter Holder Bar [B]: 57001-1128

Valve Seat Cutter Holder, $\phi 4.5$ [C]: 57001-1330

[For Exhaust Valve Seat]

Valve Seat Cutter, 45° - $\phi 27.5$: 57001-1114

Valve Seat Cutter, 32° - $\phi 28$: 57001-1119

Valve Seat Cutter, 60° - $\phi 27$: 57001-1409

[For Intake Valve Seat]

Valve Seat Cutter, 45° - $\phi 32$: 57001-1115

Valve Seat Cutter, 32° - $\phi 33$: 57001-1199

Valve Seat Cutter, 60° - $\phi 33$: 57001-1334

- ★ If the manufacturer's instructions are not available, use the following procedure.

Seat Cutter Operation Care

1. This valve seat cutter is developed to grind the valve for repair. Therefore the cutter must not be used for other purposes than seat repair.
2. Do not drop or shock the valve seat cutter, or the diamond particles may fall off.
3. Do not fail to apply engine oil to the valve seat cutter before grinding the seat surface. Also wash off ground particles sticking to the cutter with washing oil.

NOTE

○ Do not use a wire brush to remove the metal particles from the cutter. It will take off the diamond particles.

4. Setting the valve seat cutter holder in position, operate the cutter in one hand. Do not apply too much force to the diamond portion.

NOTE

○ Prior to grinding, apply engine oil to the cutter and during the operation, wash off any ground particles sticking to the cutter with washing oil.

5. After use, wash it with washing oil and apply thin layer of engine oil before storing.

Marks Stamped on the Cutter

The marks stamped on the back of the cutter [A] represent the following.

60° Cutter angle [B]

37.5 ϕ Outer diameter of cutter [C]

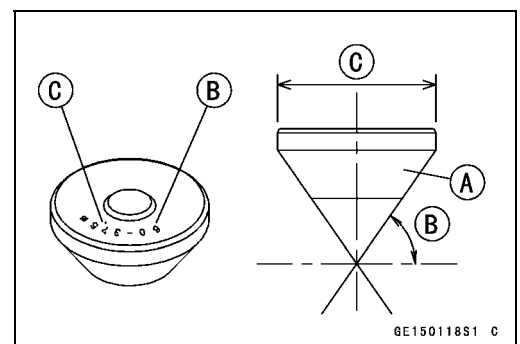
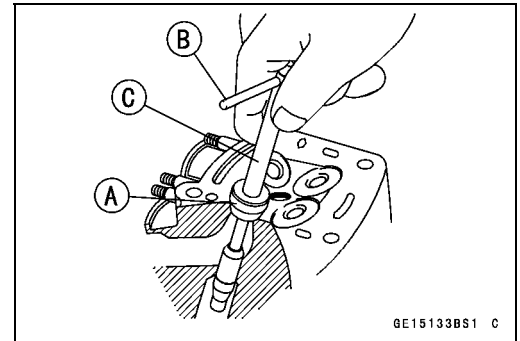

5-34 ENGINE TOP END

Valves

Operating Procedures

- Clean the seat area carefully.
- Coat the seat with machinist's dye.
- Fit a 45° cutter into the holder and slide it into the valve guide.
- Press down lightly on the handle and turn it right or left. Grind the seating surface only until it is smooth.

NOTICE

Do not grind the seat too much. Overgrinding will reduce valve clearance by sinking the valve into the head. If the valve sinks too far into the head, it will be impossible to adjust the clearance, and the cylinder head must be replaced.

- Measure the outside diameter of the seating surface with a vernier caliper.
- ★ If the outside diameter of the seating surface is too small, repeat the 45° grind until the diameter is within the specified range.
 - Widened Width [A] of engagement by machining with 45° cutter
 - Ground Volume [B] by 32° cutter
 - 32° [C]
 - Correct Width [D]
 - Ground Volume [E] by 60° cutter
 - 60° [F]

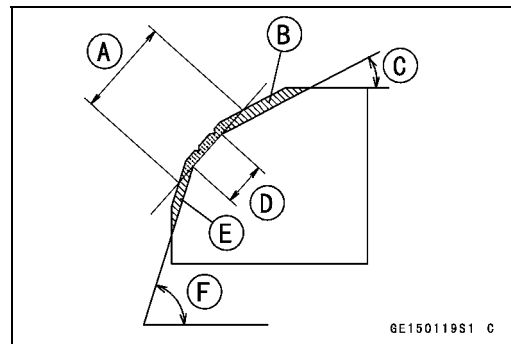

- Measure the outside diameter of the seating surface with a vernier caliper.
- ★ If the outside diameter of the seating surface is too small, repeat the 45° grind [A] until the diameter is within the specified range.
 - Original Seating Surface [B]

NOTE

- Remove all pittings or flaws from 45° ground surface.
- After grinding with 45° cutter, apply thin coat of machinist's dye to seating surface. This makes seating surface distinct and 32° and 60° grinding operation easier.
- When the valve guide is replaced, be sure to grind with 45° cutter for centering and good contact.

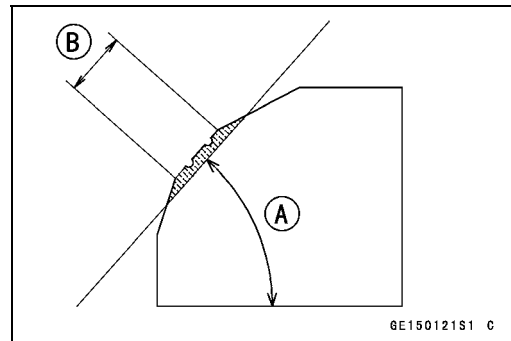

Valves

- ★ If the outside diameter [A] of the seating surface is too large, make the 32° grind described below.
- ★ If the outside diameter of the seating surface is within the specified range, measure the seat width as described below.
- Grind the seat at a 32° angle [B] until the seat outside diameter is within the specified range.
- To make the 32° grind, fit a 32° cutter into the holder, and slide it into the valve guide.
- Turn the holder one turn at a time while pressing down very lightly. Check the seat after each turn.

NOTICE

The 32° cutter removes material very quickly. Check the seat outside diameter frequently to prevent overgrinding.

- After making the 32° grind, return to the seat outside diameter measurement step above.
 - To measure the seat width, use a vernier caliper to measure the width of the 45° angle portion of the seat at several places around the seat.
 - ★ If the seat width is too narrow, repeat the 45° grind until the seat is slightly too wide, and then return to the seat outside diameter measurement step above.
 - ★ If the seat width is too wide, make the 60° [A] grind described below.
 - ★ If the seat width is within the specified range, lap the valve to the seat as described below.
 - Grind the seat at a 60° angle until the seat width is within the specified range.
 - To make the 60° grind, fit 60° cutter into the holder, and slide it into the valve guide.
 - Turn the holder, while pressing down lightly.
 - After making the 60° grind, return to the seat width measurement step above.
- Correct Width [B]

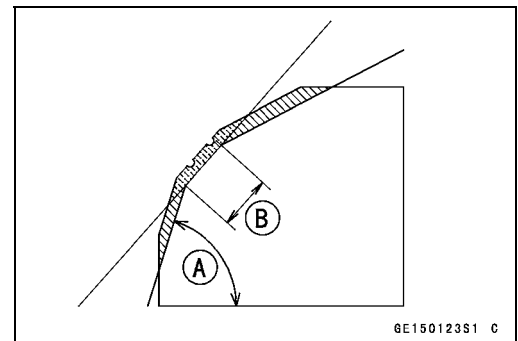
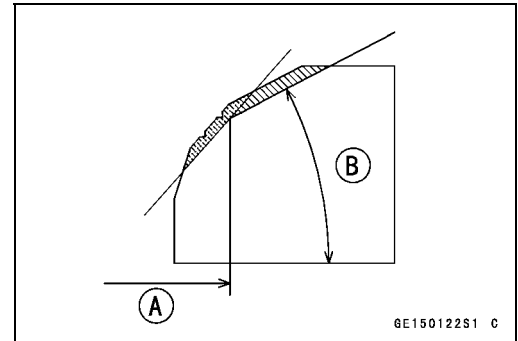

5-36 ENGINE TOP END

Valves

- Lap the valve to the seat, once the seat width and outside diameter are within the ranges specified above.
- Put a little coarse grinding compound on the face of the valve in a number of places around the valve head.
- Spin the valve against the seat until the grinding compound produces a smooth, matched surface on both the seat and the valve.
- Repeat the process with a fine grinding compound.
 - Lapper [A]
 - Valve Seat [B]
 - Valve [C]
- The seating area should be marked about in the middle of the valve face.
- ★ If the seat area is not in the right place on the valve, check to be sure the valve is the correct part. If it is, it may have been refaced too much; replace it.
- Be sure to remove all grinding compound before assembly.
- When the engine is assembled, be sure to adjust the valve clearance (see Valve Clearance Inspection in the Periodic Maintenance chapter).

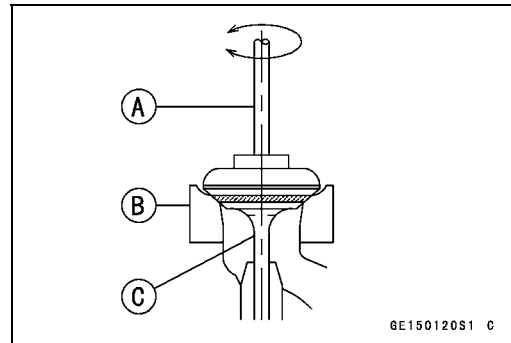

Valves

Valve Seat Repair

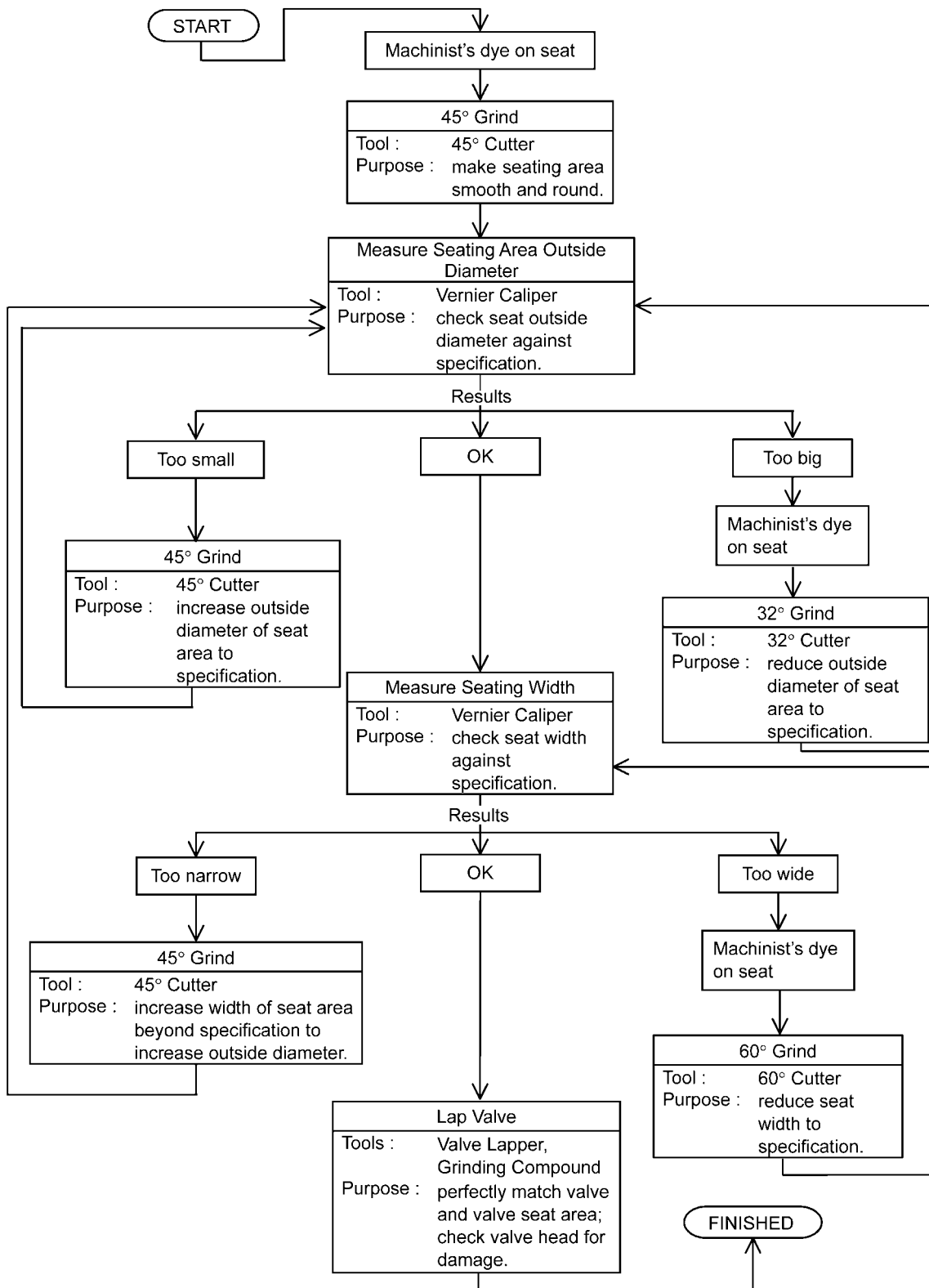

5-38 ENGINE TOP END

Cylinder, Pistons

Cylinder Removal

- Remove:
 - Lower Radiator Bolt [A]
 - Radiator Bracket Bolt [B]
 - Radiator Bracket [C]
 - Cylinder Head (see Cylinder Head Removal)
 - Engine Bracket (see Engine Removal in the Engine Removal/Installation chapter)

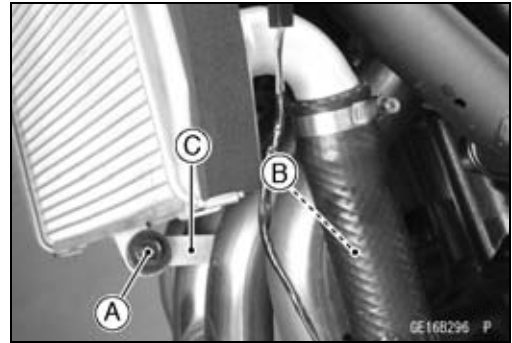

- Remove:
 - Water Hose Clamp Screw (Loosen) [A]
 - Water Hose [B]

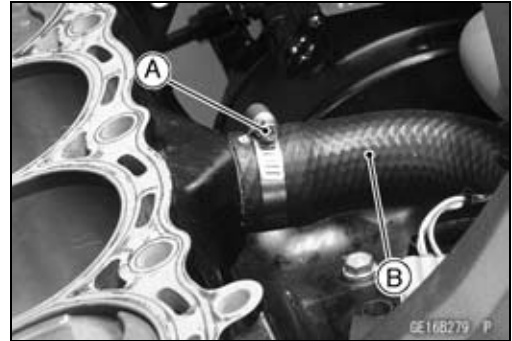

- Remove:
 - Upper Engine Mounting Bolts (Both Sides) [A]
- Loosen:
 - Upper Adjusting Collar Locknut [B]
- Special Tool - Engine Mount Nut Wrench [C]: 57001-1450
- Loosen:
 - Upper Adjusting Collar [D]

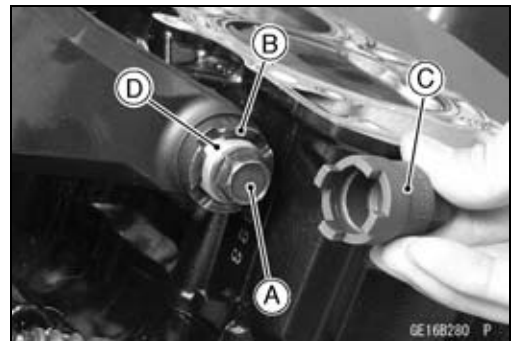

- Remove:
 - Cylinder [A]

NOTE

○ If it is hard to remove it, tap lightly using a plastic-faced mallet [B].



Cylinder Installation

NOTE

○ If a new cylinder is used, use new piston ring.

- Replace the cylinder gasket [A] with a new one.
- Install the dowel pins [B] and new cylinder gasket.
- Apply molybdenum disulfide oil solution to the cylinder bore.

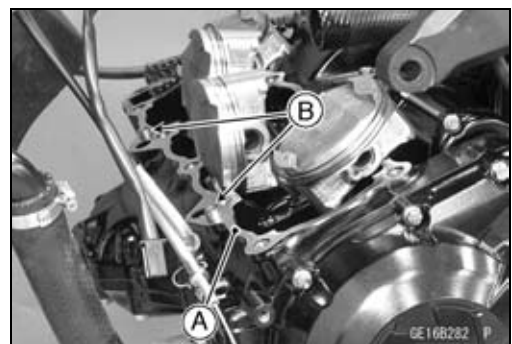

Cylinder, Pistons

- The piston ring openings must be positioned as shown in the figure. The openings of the oil ring steel rails must be about 30 ~ 40° of angle from the opening of the top ring.

- Top Ring [A]
- Second Ring [B]
- Upper Oil Ring Steel Rail [C]
- Oil Ring Expander [D]
- Lower Oil Ring Steel Rail [E]
- Dent [F]
- 30 ~ 40° [G]

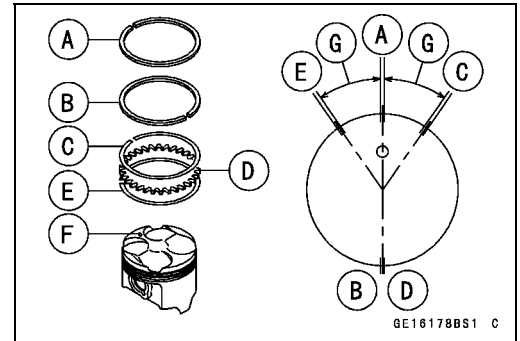

- Position the crankshaft at #2, 3 piston TDC.
- Prepare two auxiliary head bolts with their head cut.
- Install the two cylinder head bolts [A] diagonally in the crankcase.
- Install the cylinder block [B].
- Pistons [C]
- First insert the #2, 3 pistons, and then rotate the crankshaft at 90° angle.
- Tighten the upper engine mounting bolts and engine bracket bolts after cylinder head bolts tightend.

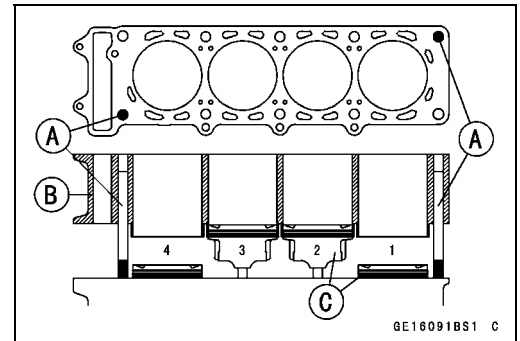

Piston Removal

- Remove the cylinder (see Cylinder Removal).
- Place a clean cloth under the pistons and remove the piston pin snap ring [A] from the outside of each piston.

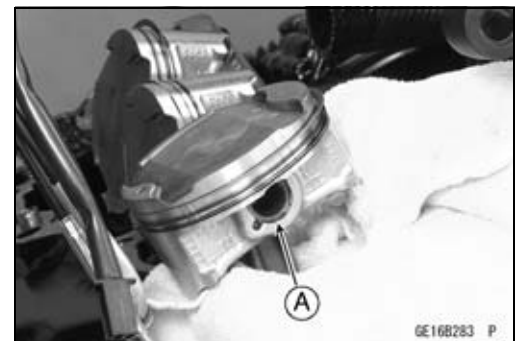

- Remove the piston pins.
Special Tool - Piston Pin Puller Assembly [A]: 57001-910
- Remove the pistons.

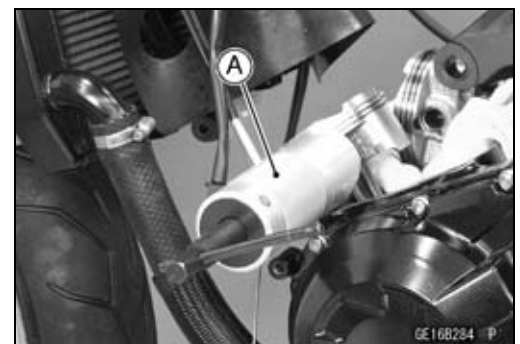

- Carefully spread the ring opening with your thumbs and then push up on the opposite side of the ring [A] to remove it.
- Remove the 3-piece oil ring with your thumbs in the same manner.

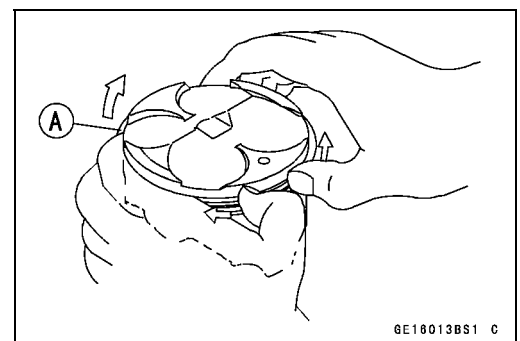

5-40 ENGINE TOP END

Cylinder, Pistons

Piston Installation

- Apply molybdenum disulfide oil solution to the oil ring expander, and install the oil ring expander [A] in the bottom piston ring groove so the ends [B] not butt together.
- Apply molybdenum disulfide oil solution to the oil ring steel rails, and install the oil ring steel rails, one above the expander and one below it.
- Spread the rail with your thumbs, but only enough to fit the rail over the piston.
- Release the rail into the bottom piston ring groove.

NOTE

○ The oil ring rails have no "top" or "bottom".

- Do not mix up the top and second ring.
- Install the top ring [A] so that the "1T" mark [B] faces up.
- Install the second ring [C] so that the "2T" mark [D] faces up.
- Apply molybdenum disulfide oil solution to the piston rings.

NOTE

○ If a new piston is used, use new piston ring.

- Install the piston with its dent mark facing forward.
- Fit a new piston pin snap ring into the side of the piston so that the ring opening [A] does not coincide with the slit [B] of the piston pin hole.
- Apply molybdenum disulfide oil solution to the piston pins and piston journals.
- When installing the piston pin snap ring, compress it only enough to install it and no more.

NOTICE

Do not reuse snap rings, as removal weakens and deforms them. They could fall out and score the cylinder wall.

- Install the cylinder (see Cylinder Installation).

Cylinder Wear Inspection

- Since there is a difference in cylinder wear in different directions, take a side-to-side and a front-to-back measurement at each of the two locations (total of four measurements) as shown in the figure.
- ★ If any of the cylinder inside diameter measurements exceeds the service limit, replace the cylinder.
 - 10 mm (0.39 in.) [A]
 - 60 mm (2.36 in.) [B]

Cylinder Inside Diameter

Standard: 76.990 ~ 77.006 mm (3.0311 ~ 3.0317 in.)

Service Limit: 77.09 mm (3.035 in.)

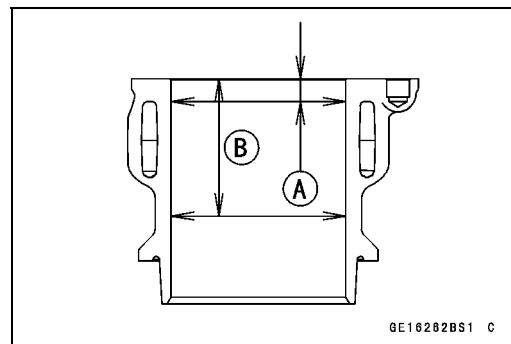
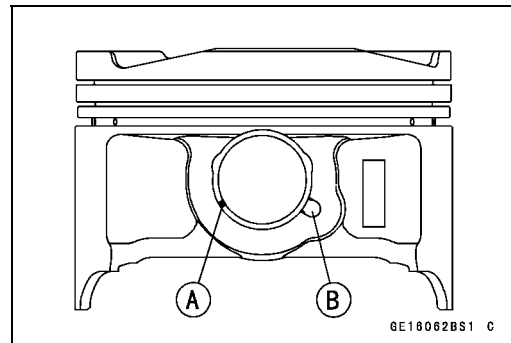
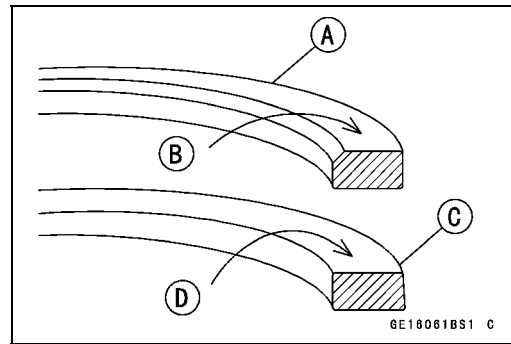
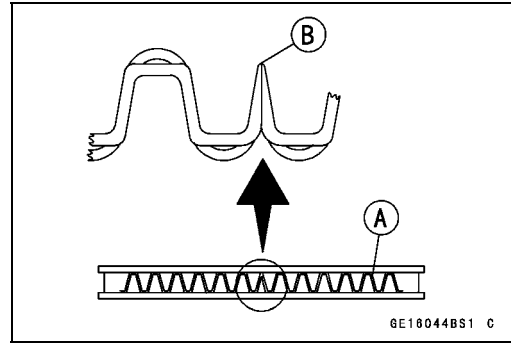

Cylinder, Pistons

Piston Wear Inspection

- Measure the outside diameter [A] of each piston 11 mm (0.43 in.) [B] up from the bottom of the piston at a right angle to the direction of the piston pin.
- ★ If the measurement is under service limit, replace the piston.

Piston Diameter

Standard:	76.974 ~ 76.984 mm (3.0305 ~ 3.0309 in.)
Service Limit:	76.82 mm (3.024 in.)

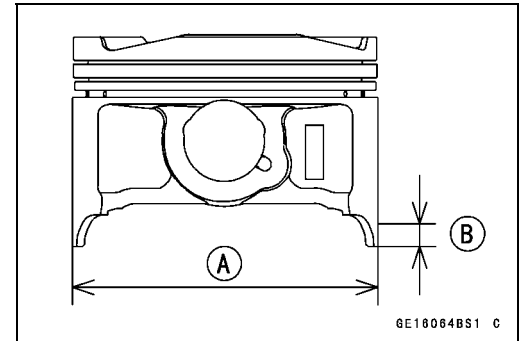

Piston Ring, Piston Ring Groove Wear Inspection

- Check for uneven groove wear by inspecting the ring seating.
- ★ The rings should fit perfectly parallel to groove surfaces. If not, replace the piston and all the piston rings.
- With the piston rings in their grooves, make several measurements with a thickness gauge [A] to determine piston ring/groove clearance.

Piston Ring/Groove Clearance

Standard:

Top	0.03 ~ 0.07 mm (0.0012 ~ 0.0028 in.)
Second	0.02 ~ 0.06 mm (0.0008 ~ 0.0024 in.)

Service Limit:

Top	0.17 mm (0.0067 in.)
Second	0.16 mm (0.0063 in.)

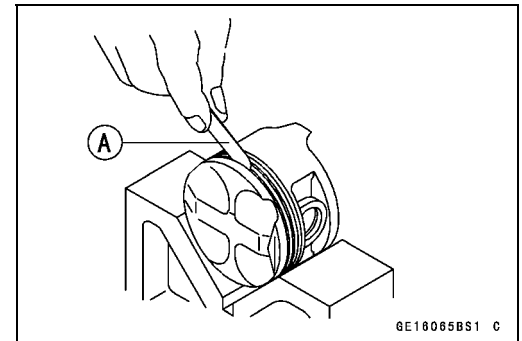

Piston Ring Groove Width Inspection

- Measure the piston ring groove width.
- Use a vernier caliper at several points around the piston.

Piston Ring Groove Width

Standard:

Top [A]	0.82 ~ 0.84 mm (0.0323 ~ 0.0331 in.)
Second [B]	0.81 ~ 0.83 mm (0.0319 ~ 0.0327 in.)

Service Limit:

Top [A]	0.92 mm (0.0362 in.)
Second [B]	0.91 mm (0.0358 in.)

- ★ If the width of any of the two grooves are wider than the service limit at any point, replace the piston.

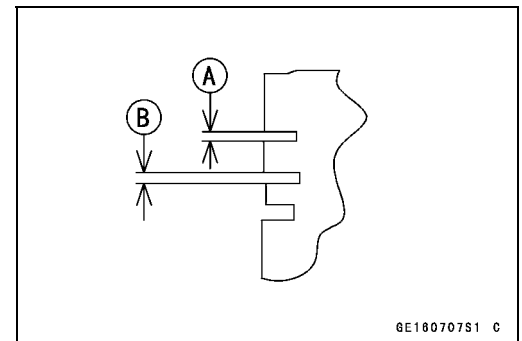

5-42 ENGINE TOP END

Cylinder, Pistons

Piston Ring Thickness Inspection

- Measure the piston ring thickness.
- Use the micrometer to measure at several points around the ring.

Piston Ring Thickness

Standard:

Top [A]	0.77 ~ 0.79 mm (0.0303 ~ 0.0311 in.)
Second [B]	0.77 ~ 0.79 mm (0.0303 ~ 0.0311 in.)

Service Limit:

Top [A]	0.70 mm (0.028 in.)
Second [B]	0.70 mm (0.028 in.)

- ★ If any of the measurements is less than the service limit on either of the rings, replace all the rings.

NOTE

- When using new rings in a used piston, check for uneven groove wear. The rings should fit perfectly parallel to the groove sides. If not, replace the piston.

Piston Ring End Gap Inspection

- Place the piston ring [A] inside the cylinder, using the piston to locate the ring squarely in place. Set it close to the bottom of the cylinder, where cylinder wear is low.
- Measure the gap [B] between the ends of the ring with a thickness gauge.

Piston Ring End Gap

Standard:

Top	0.20 ~ 0.30 mm (0.0079 ~ 0.0118 in.)
Second	0.38 ~ 0.48 mm (0.0150 ~ 0.0189 in.)

Service Limit:

Top	0.6 mm (0.024 in.)
Second	0.8 mm (0.031 in.)

- ★ If the end gap of either ring is greater than the service limit, replace all the rings.

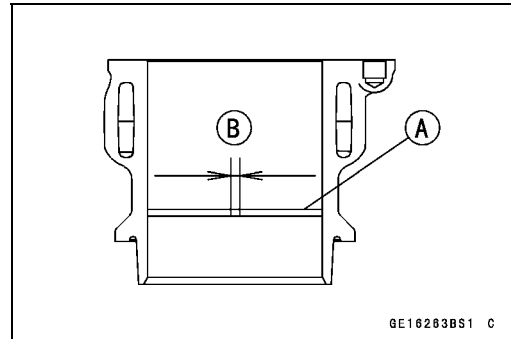
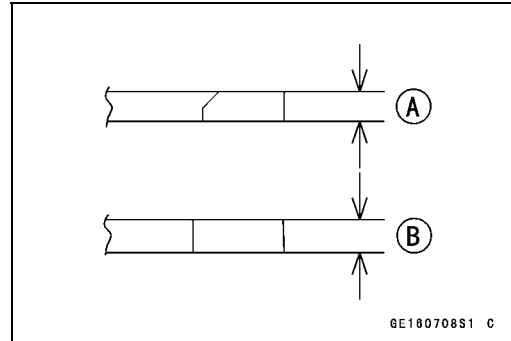

Throttle Body Assy Holder

Throttle Body Assy Holder Removal

- Remove:
 - Throttle Body Assy (see Throttle Body Assy Removal in the Fuel System (DFI) chapter)
 - Clamps [A]
 - Bolts [B]
 - Throttle Body Assy Holders [C]

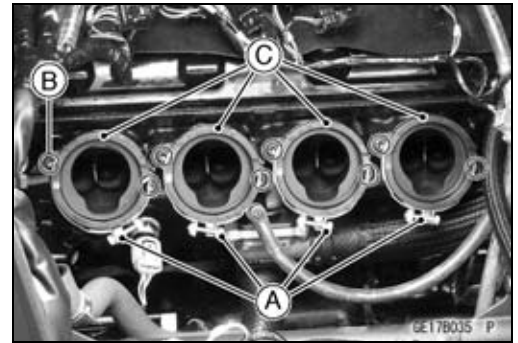

Throttle Body Assy Holder Installation

- Replace the O-rings [A] with new ones.
- Apply grease to the O-rings, and install them.
- Apply a non-permanent locking agent to the throttle body assy holder bolts.
- Tighten:
 - Torque - Throttle Body Assy Holder Bolts: 12 N·m (1.2 kgf·m, 106 in·lb)**

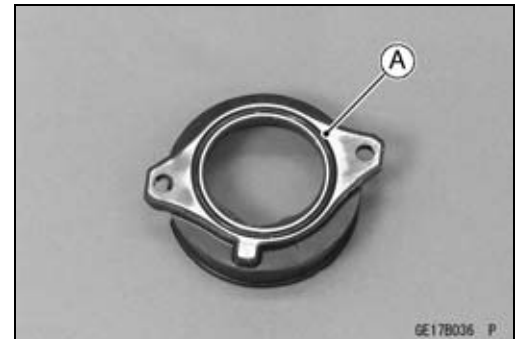

- Install the clamps [A] so that their projections [B] fit on the holes [C] of the holders.

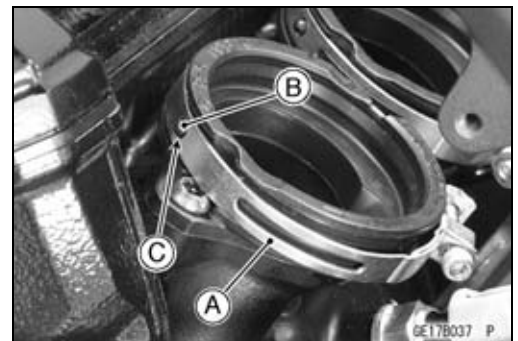

- Be sure that the clamp bolt heads [A] face as shown in the figure.

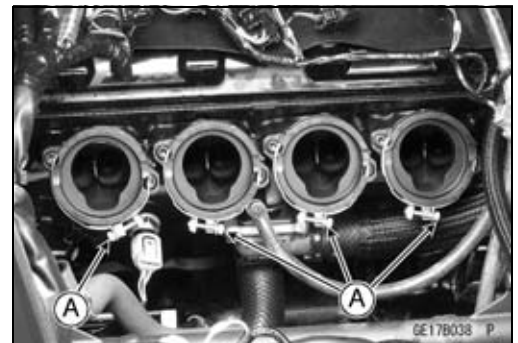

5-44 ENGINE TOP END

Muffler

⚠ WARNING

The exhaust pipe or muffler body can become extremely hot during normal operation and cause severe burns. Do not remove the exhaust pipe or muffler body while it is hot.

Muffler Body Removal

Left Muffler Body

- Loosen the muffler body clamp bolt [A].
- Remove:
 - Left Muffler Body Mounting Bolt [B] and Nut
 - Left Muffler Body [C]

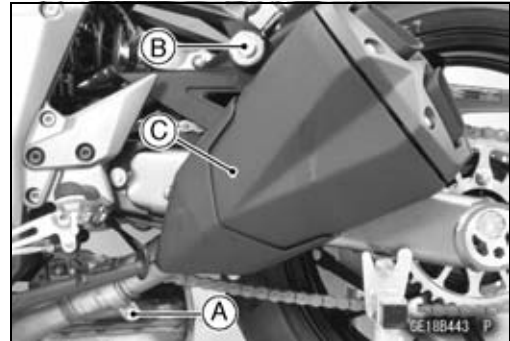

Right Muffler Body

- Clear the exhaust butterfly valve cables [A] from the clamp [B].

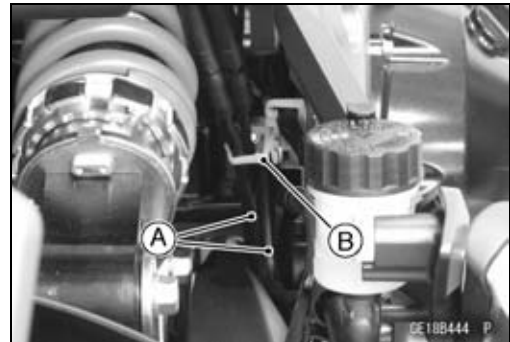

- Remove:
 - Rear Lower Fairing (see Rear Lower Fairing Removal in the Frame chapter)
- Remove the holder clamp bolt [A] to free the holder clamp [B] from the frame.

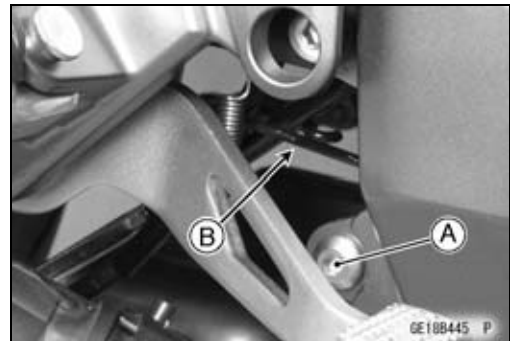

- Slide the dust covers [A].
- Loosen the locknuts [B], and turn the adjusters [C] to give the cable plenty of play.

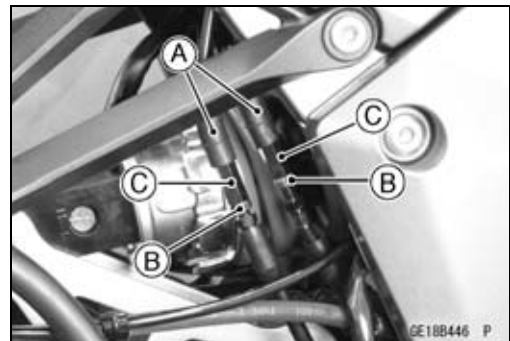

Muffler

- Remove:
 - Muffler Body Clamp Bolt [A] (Loosen)
 - Right Muffler Body Mounting Bolt [B] and Nut
 - Right Muffler Body [C] (with the cable installed)

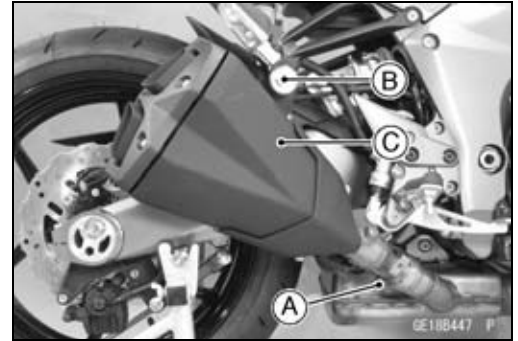

- Remove:
 - Bolts [A]
 - Exhaust Butterfly Valve Pulley Cover [B]

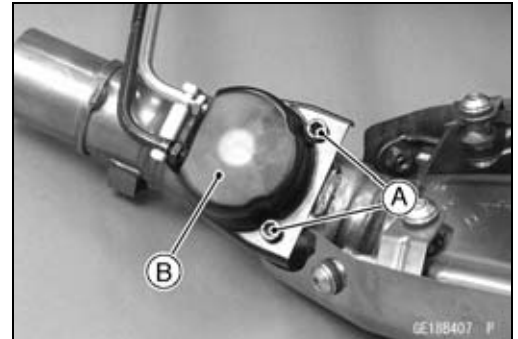

- Loosen the locknuts [A].
- Remove the cable lower ends [B].

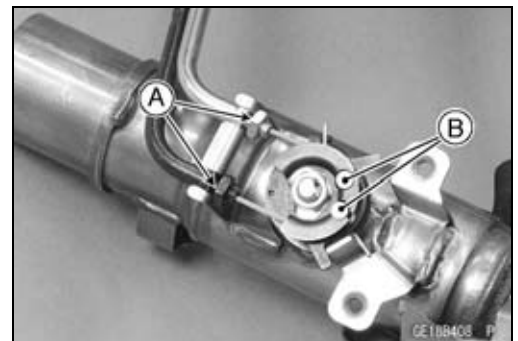

Muffler Body Installation

- Replace the muffler body gaskets [A] with new ones.
- Install the muffler body gaskets until it is bottomed so that the inside chamfer side faces rear [B].
- Install the muffler body clamps [C] so that the insert the projection [D] into the clamp slit [E].
 - Downside [F]
 - Inside [G]
 - Viewed from Rear [H]
- Install the exhaust butterfly valve cables (see Exhaust Butterfly Valve Cable Installation).
- Install the muffler bodies until it stops at the bottom surface of the exhaust pipe.
- Install the muffler body mounting bolts and nuts.
- Tighten:
 - Torque - Muffler Body Mounting Bolts [I]: 34 N·m (3.5 kgf·m, 25 ft·lb)**
- Turn the muffler body clamps outward until it stops at the slit ends.
- Tighten:
 - Torque - Muffler Body Clamp Bolt [J]: 21 N·m (2.1 kgf·m, 15 ft·lb)**

5-46 ENGINE TOP END

Muffler

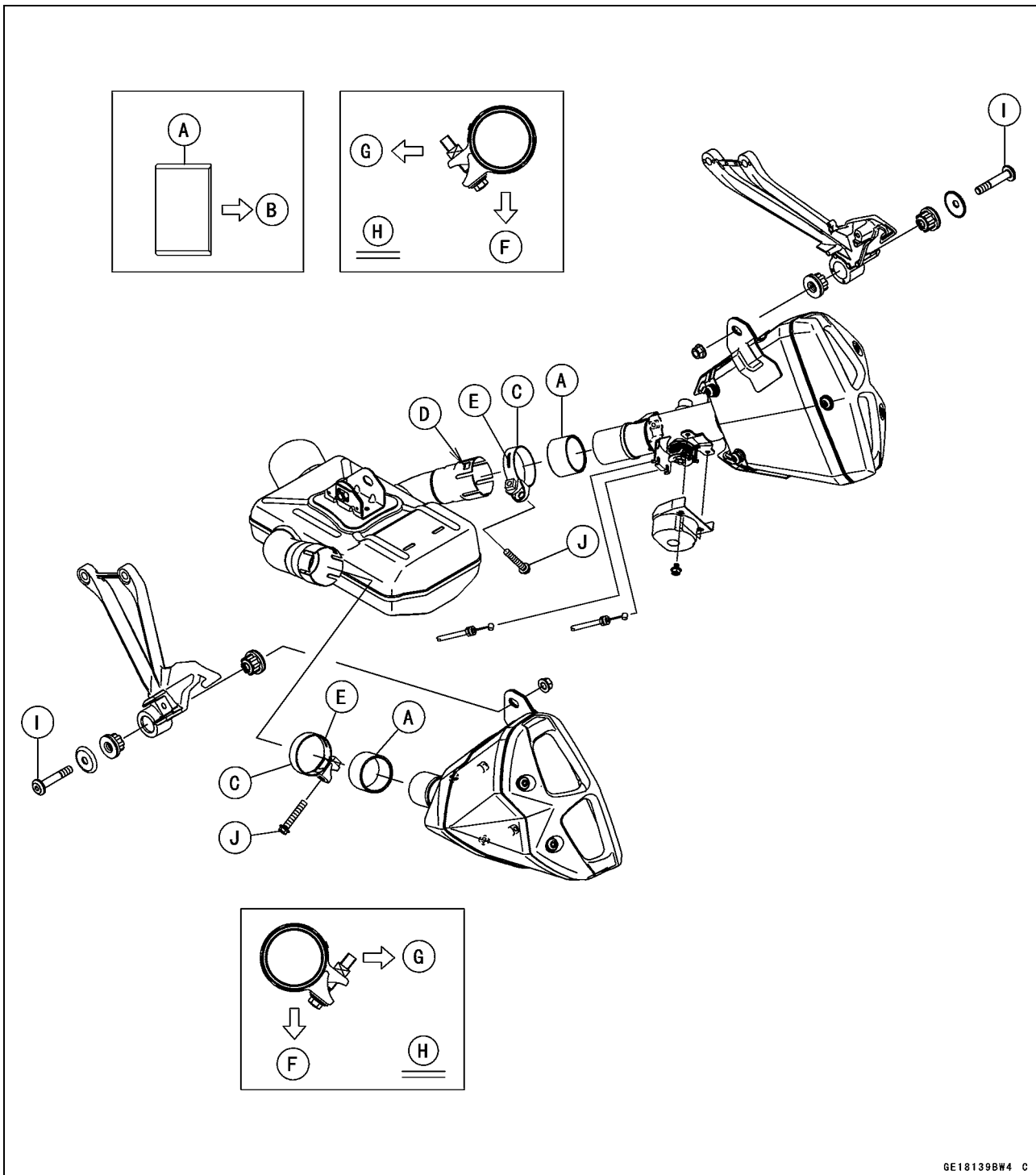

- Thoroughly warm up the engine, wait until the engine cools down, retighten all the bolts and nuts.
- Install the removed parts (see appropriate chapters).
- When installing, run the cables correctly (see Cable, Wire, and Hose Routing section in the Appendix chapter).

Muffler

Exhaust Pipe Removal

- Remove:
 - Muffler Bodies (see Muffler Body Removal)
 - Oxygen Sensor (see Oxygen Sensor Removal (Equipped Models) in the Electrical System chapter)
 - Support the premuffler chamber with the suitable stand [A].
 - Loosen the premuffler chamber mounting bolt [B].
-
- Remove:
 - Exhaust Pipe Holder Nuts [A]
 - Exhaust Pipe (Premuffler Chamber) [B]
 - (In the photo, the radiator has been removed for clarity)

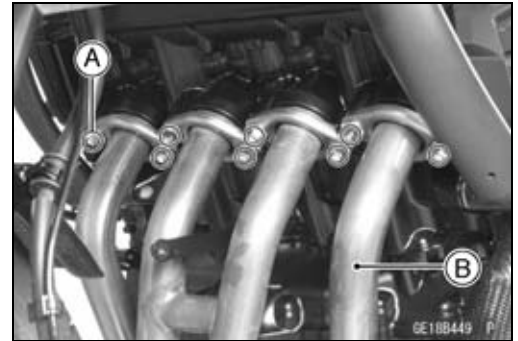
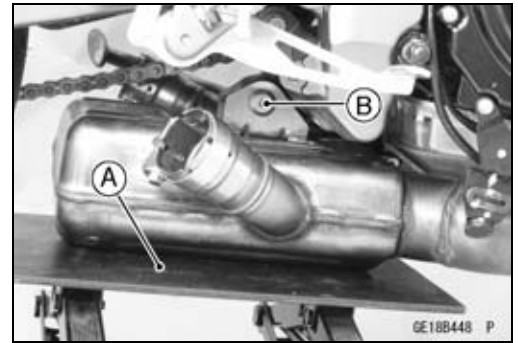

Exhaust Pipe Installation

- Replace the exhaust pipe gaskets [A] with new ones and install them.
 - Install the exhaust pipe.
 - Tighten the exhaust pipe holder nuts [B] and mounting bolt [C].
- Torque - Premuffler Chamber Mounting Bolt [C]: 34 N·m (3.5 kgf·m, 25 ft·lb)**
- Install the muffler bodies (see Muffler Body Installation).
 - Thoroughly warm up the engine, wait until the engine cools down, retighten all the bolts and nuts.
 - Install the removed parts (see appropriate chapters).
 - When installing, run the cables and leads correctly (see Cable, Wire, and Hose Routing section in the Appendix chapter).

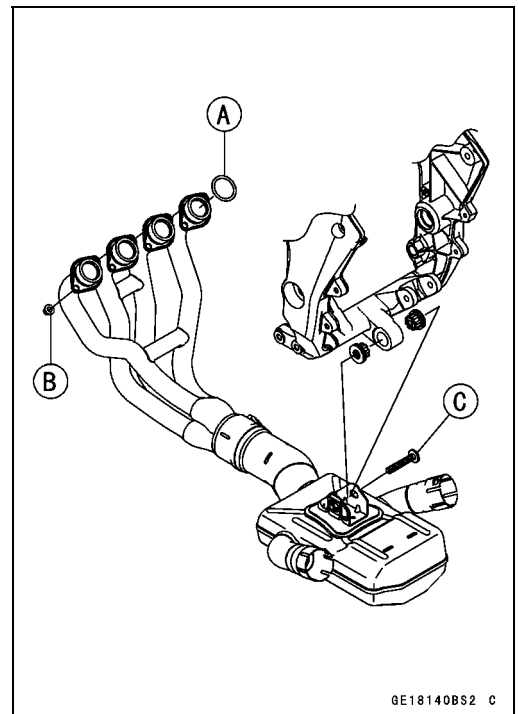

Exhaust Butterfly Valve Cable Removal

- Remove:
 - Clamp [A]
 - Exhaust Butterfly Valve Cable Upper Ends [B]
 - Exhaust Butterfly Valve Cables [C]
- Remove the cable lower ends (see Muffler Body Removal).

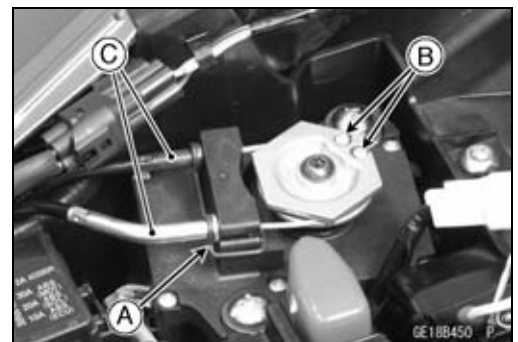

5-48 ENGINE TOP END

Muffler

Exhaust Butterfly Valve Cable Installation

- Confirm whether pulley [A] is an angle as shown in the figure.
41.7° ±0.7° [B]
- This position is original position of the pulley.

NOTE

- Correct the position electrically after confirming use is discontinued and there is no damage when differing from the angle of shown in the figure.

NOTICE

Do not correct the pulley position with the tool, forcibly. The actuator damage will occur.

- ★ If the angle is wrong, adjust the pulley (see Exhaust Butterfly Valve Actuator Installation in the Fuel System (DFI) chapter).
- Run the exhaust butterfly valve cables correctly (see Cable, Wire, and Hose Routing section in the Appendix chapter).
- Install the lower ends of the exhaust butterfly valve cables to the pulley of the right muffler body as shown in the figure.
- Make sure fit the guides [A] on the cable to the holder grooves [B].
 - Open Cable (White) [C]
 - Close Cable (Black) [D]
- Tighten the cable locknut securely.
- Install the right muffler body (see Muffler Body Installation).

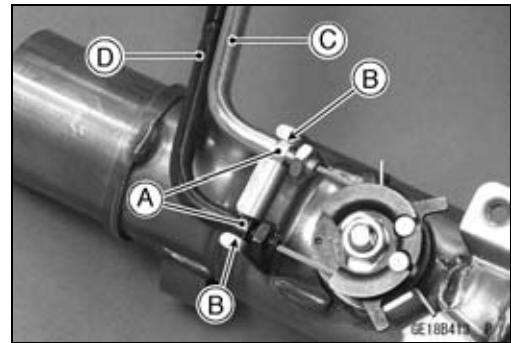
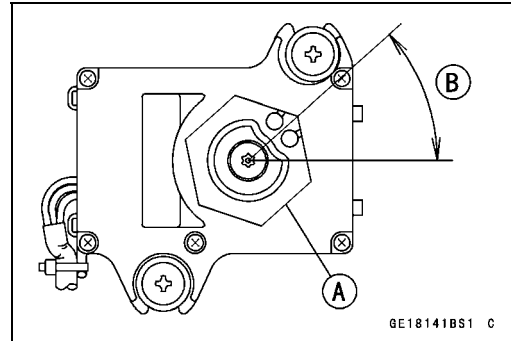

Muffler

- Install the upper ends of the exhaust butterfly valve cables to the pulley of the exhaust butterfly valve actuator, following the specified installing sequence.
 - First, install the close cable (black) [A].
 - Second, install the open cable (white) [B].
 - Third, stretch the open cable (white) by using the adjuster [C].
 - Turn the adjuster counterclockwise until the play of the open cable becomes no play.

NOTICE

To keep the correct exhaust butterfly valve position, be sure to adjust the open cable first. Do not overstretch the cable.

- Fourth, tighten the adjuster locknut (white) [D] of the open cable securely.
- Fifth, stretch the close cable (black) by using the adjuster [E].
- Turn the adjuster counterclockwise until the play of the close cable becomes no play.
- Sixth, turn the adjuster of the close cable (black) clockwise by 1/2 to 1 rotation.
- Seventh, tighten the adjuster locknut (black) [F] of the close cable securely.
- After installation, cover the dust covers on the adjusters.
- Fix the exhaust butterfly valve cables with the clamps [G].
- Run the exhaust butterfly cables into the holder clamps, and install the holder clamps.
- After connecting the cables, turn the ignition switch ON and make sure that the pulley turns clockwise and counterclockwise, then it returns clockwise slightly.

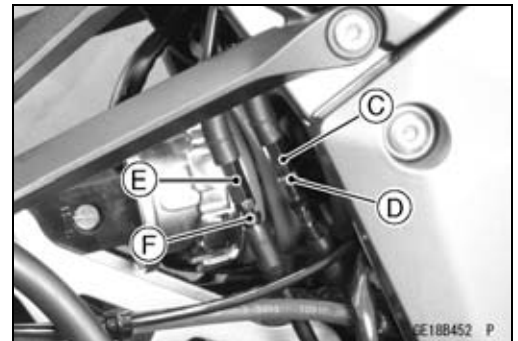
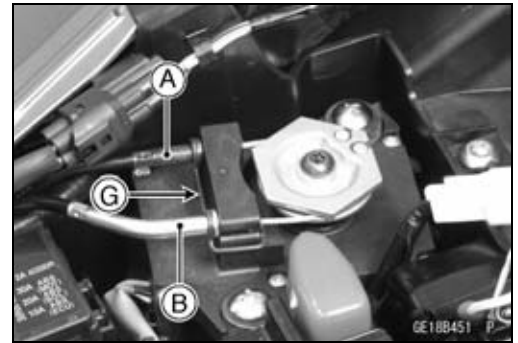

Clutch

Table of Contents

Exploded View.....	6-2
Specifications	6-4
Special Tool and Sealant.....	6-5
Clutch Lever and Cable.....	6-6
Clutch Lever Free Play Inspection.....	6-6
Clutch Lever Free Play Adjustment	6-6
Clutch Cable Removal	6-6
Clutch Cable Installation	6-6
Clutch Cable Lubrication.....	6-6
Clutch Lever Assembly Installation	6-6
Clutch Cover.....	6-7
Clutch Cover Removal.....	6-7
Clutch Cover Installation.....	6-7
Release Shaft Removal	6-7
Release Shaft Installation	6-8
Clutch Cover Disassembly.....	6-8
Clutch Cover Assembly.....	6-9
Clutch	6-10
Clutch Removal.....	6-10
Clutch Installation.....	6-10
Clutch Plate Assembly Inspection.....	6-13
Clutch Plate Assembly Adjustment.....	6-13
Clutch Plate, Wear, Damage Inspection	6-14
Clutch Plate Warp Inspection.....	6-14
Clutch Spring Free Length Measurement.....	6-14
Clutch Housing Finger Inspection	6-14
Clutch Housing Spline Inspection	6-14

6-2 CLUTCH

Exploded View

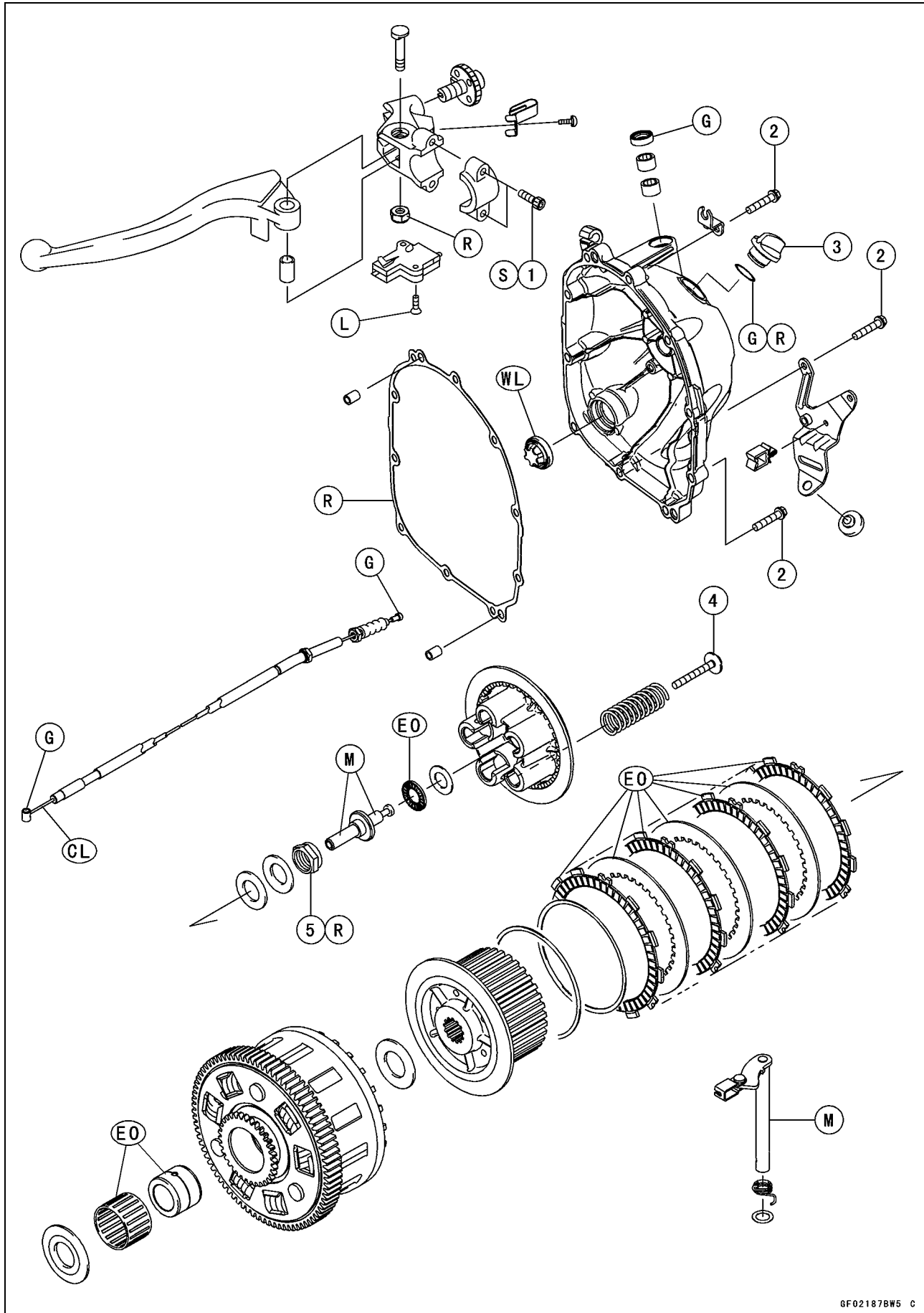

Exploded View

No.	Fastener	Torque			Remarks
		N·m	kgf·m	ft·lb	
1	Clutch Lever Assembly Clamp Bolts	7.8	0.80	69 in·lb	S
2	Clutch Cover Bolts	9.8	1.0	87 in·lb	
3	Oil Filler Plug	2.0	0.20	18 in·lb	
4	Clutch Spring Bolts	9.0	0.90	80 in·lb	
5	Clutch Hub Nut	135	13.8	99.6	R

CL: Apply cable lubricant.

EO: Apply engine oil.

G: Apply grease.

L: Apply a non-permanent locking agent.

M: Apply molybdenum disulfide grease.

R: Replacement Parts

S: Follow the specified tightening sequence.

WL: Apply soap and water solution or rubber lubricant.

6-4 CLUTCH

Specifications

Item	Standard	Service Limit
Clutch Lever Free Play	2 ~ 3 mm (0.08 ~ 0.12 in.)	— — —
Clutch		
Clutch Plate Assembly Length	51.1 ~ 51.7 mm (2.01 ~ 2.04 in.)	— — —
Friction Plate Thickness	2.72 ~ 2.88 mm (0.107 ~ 0.113 in.)	2.4 mm (0.094 in.)
Friction and Steel Plate Warp	0.15 mm (0.0059 in.) or less	0.3 mm (0.012 in.)
Clutch Spring Free Length	64.8 mm (2.55 in.)	61.8 mm (2.43 in.)

Special Tool and Sealant

Clutch Holder:
57001-1243

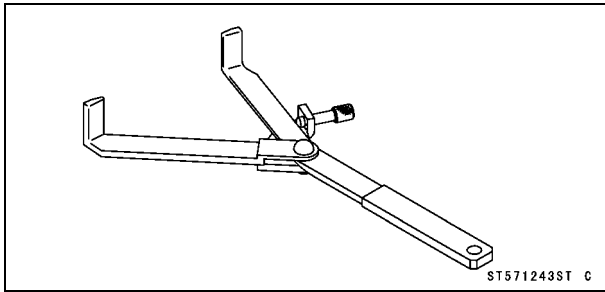

Liquid Gasket, TB1211F:
92104-0004

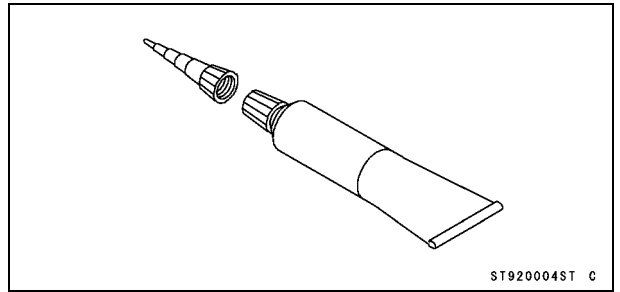

6-6 CLUTCH

Clutch Lever and Cable

Clutch Lever Free Play Inspection

- Refer to the Clutch Operation Inspection in the Periodic Maintenance chapter.

Clutch Lever Free Play Adjustment

- Refer to the Clutch Operation Inspection in the Periodic Maintenance chapter.

Clutch Cable Removal

- Remove the right lower fairing (see Lower Fairing Removal in the Frame chapter).
- Slide the dust cover [A] at the clutch cable lower end out of place.
- Loosen the nuts [B], and slide the lower end of the clutch cable to give the cable plenty of play.

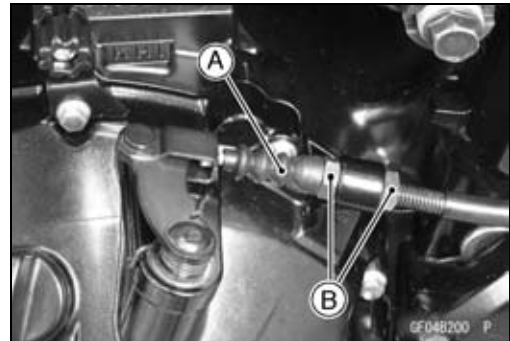

- Screw in the adjuster [A].
- Line up the slots [B] in the clutch lever and adjuster, and then free the cable from the lever.
- Free the clutch inner cable tip from the clutch release lever.
- Pull the clutch cable out of the frame.

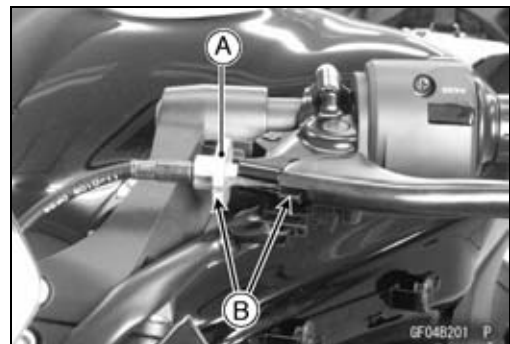

Clutch Cable Installation

- Run the clutch cable correctly (see Cable, Wire, and Hose Routing section in the Appendix chapter).
- Adjust the clutch cable (see Clutch Operation Inspection in the Periodic Maintenance chapter).

Clutch Cable Lubrication

- Refer to the Chassis Parts Lubrication in the Periodic Maintenance chapter.

Clutch Lever Assembly Installation

- Install the clutch lever so that the mating surface [A] of the clutch lever clamp is aligned with the punch mark [B].
- Tighten the upper clamp bolt first, and then the lower clamp bolt. There will be a gap at the lower part of the clamp after tightening.

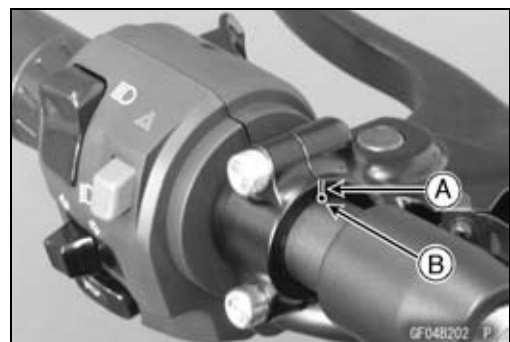

Clutch Cover

Clutch Cover Removal

- Remove:
 - Rear Lower Fairing (see Rear Lower Fairing Removal in the Frame chapter)
 - Engine Oil (Drain, see Engine Oil Change in the Periodic Maintenance chapter)
 - Clutch Cable Lower End
 - Clutch Cover Mounting Bolts [A]



- Turn the release lever [A] toward the rear as shown in the figure, and remove the clutch cover [B].
About 90° [C]

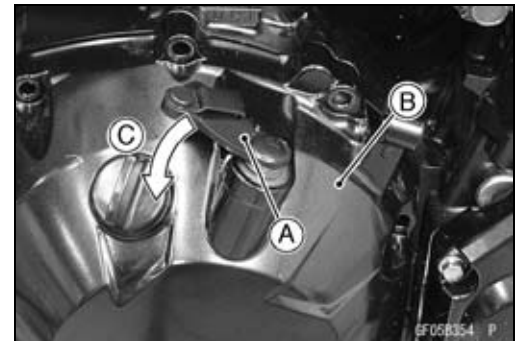

Clutch Cover Installation

- Be sure to dowel pins [A].
- Apply silicone sealant to the area [B] where the mating surface of the crankcase touches the clutch cover gasket.
- Using a high-flash point solvent, clean off any oil or dirt that may be on the liquid gasket coating area. Dry them with a clean cloth.

Sealant - Liquid Gasket, TB1211F: 92104-0004

- Replace the clutch cover gasket with a new one and install it.
- Tighten:

Torque - Clutch Cover Bolts: 9.8 N·m (1.0 kgf·m, 87 in·lb)

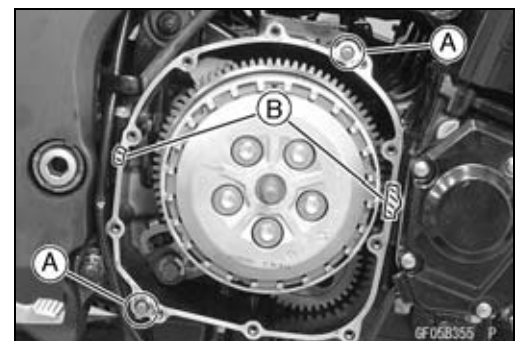

Release Shaft Removal

NOTICE

Do not remove the clutch release lever and shaft assembly unless it is absolutely necessary. If removed, the oil seal replacement may be required.

- Remove the clutch cover (see Clutch Cover Removal).
- Pull the release lever and shaft assembly [A] straight out of the clutch cover.



6-8 CLUTCH

Clutch Cover

Release Shaft Installation

- Apply grease to the oil seal lips on the upper ridge of the clutch cover.
- Apply engine oil to the needle bearings in the hole of the clutch cover.
- Apply molybdenum disulfide grease to the pusher-holding portion [A] on the release shaft.
- Install the washer [B] and spring [C].
- Insert the release shaft straight into the upper hole of the clutch cover.

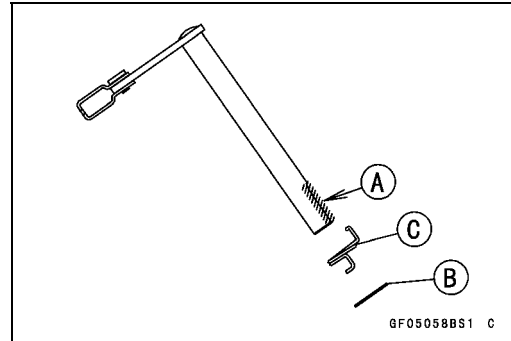

NOTICE

When inserting the release shaft, be careful not to remove the spring of the oil seal.

- Fit the spring [A] as shown in the figure.
Viewed from Rear [B]
Release Shaft [C]
Clutch Cover [D]

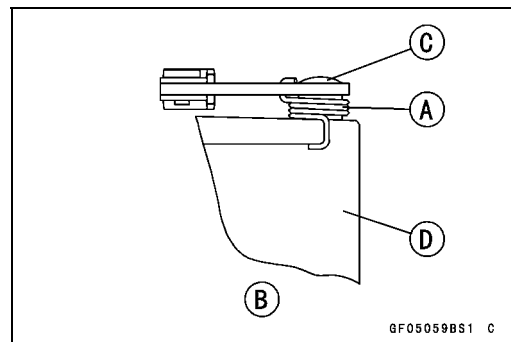

Clutch Cover Disassembly

- Remove:
Clutch Cover (see Clutch Cover Removal)
Release Lever and Shaft Assembly (see Release Shaft Removal)
Oil Filler Plug [A]
Oil Seal [B]
Needle Bearing [C]
- Remove:
Needle Bearing [A]
Oil Level Gauge [B]

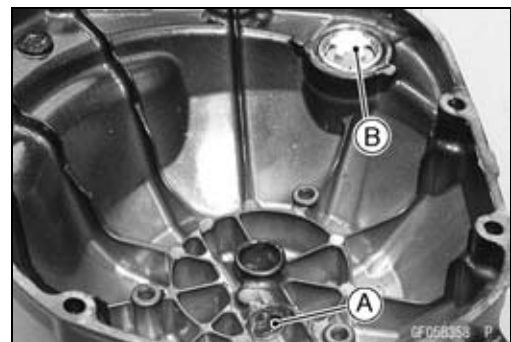
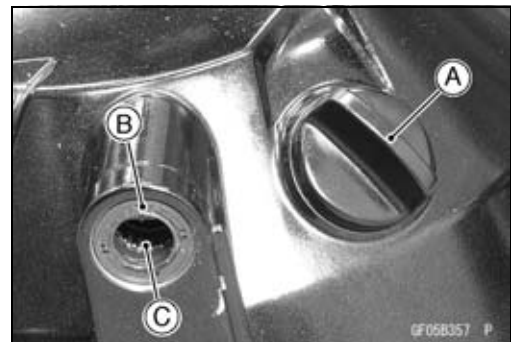

Clutch Cover

Clutch Cover Assembly

- Replace the needle bearings and oil seal with new ones.

NOTE

○ Install the needle bearings so that the manufacture's mark face out.

- Install the needle bearings [A] and oil seal [B] position as shown in the figure.

Press the needle bearing until the bottom [C].

Press the needle bearing so that the bearing surface [D] is flush with the housing end of clutch cover [E].

- Apply water to the rubber portion [A] of the oil level gauge.

- Press the gauge until the bottom so that its projection [B] faces inside of the clutch cover [C].

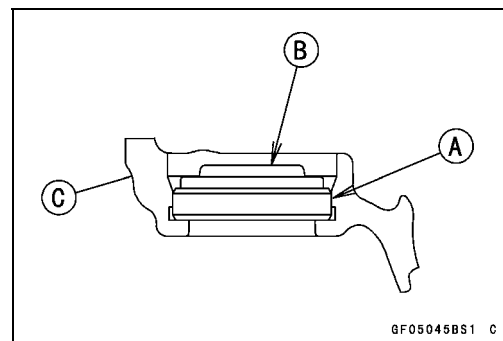
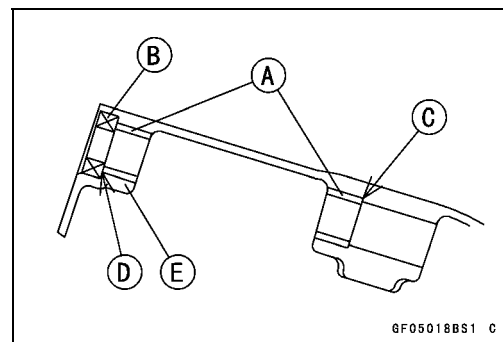

- Replace the O-ring [A] of the oil filler plug [B] with a new one.

- Apply grease to the O-ring.

- Tighten:

Torque - Oil Filler Plug: 2.0 N·m (0.20 kgf·m, 18 in·lb)

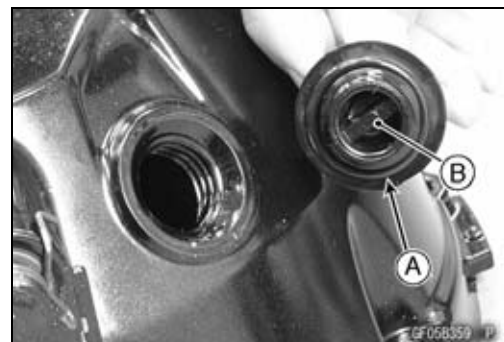

6-10 CLUTCH

Clutch

Clutch Removal

- Remove:
 - Clutch Cover (see Clutch Cover Removal)
 - Clutch Spring Bolts [A]
 - Clutch Springs
 - Clutch Spring Plate [B] (with Washer, Needle Bearing and Pusher [C])
- Remove:
 - Friction Plates and Steel Plates
 - Spring and Spring Seat

NOTE

- The two plates at both ends are different from the plate installed between these plates.
However, it is impossible to identify it on externals.
- Mark and record the locations of the friction plates so that they can be reinstalled in their original positions.

- Holding the clutch hub [A], remove the nut [B] and washers.

Special Tool - Clutch Holder [C]: 57001-1243

- Remove:
 - Clutch Hub
 - Spacer ($\phi 47 \times \phi 25.5$)

- Using the two M4 bolts or screws [A], pull out the sleeve [B], and then remove the needle bearing [C] and clutch housing.
- Remove the spacer ($\phi 56 \times \phi 25$).

Clutch Installation

- Install the spacer ($\phi 56 \times \phi 25$) [A] so that the tapered side [B] faces inward.

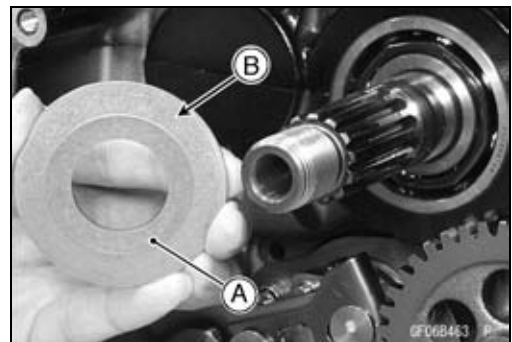
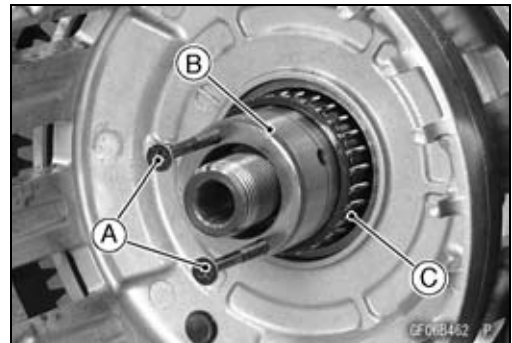
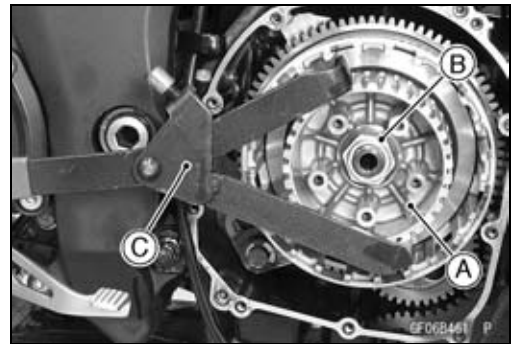
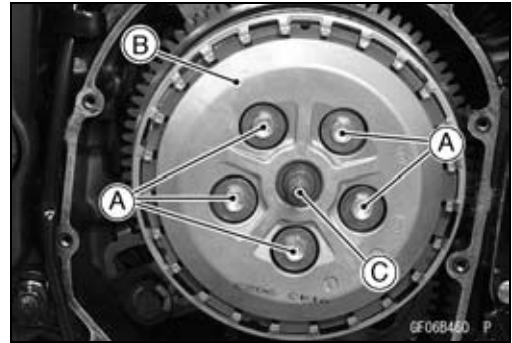

Clutch

- Install the clutch housing [A] to the drive shaft.
- While holding the clutch housing, install the needle bearing [B] and sleeve [C].
- The holes [D] of the sleeve face outward.

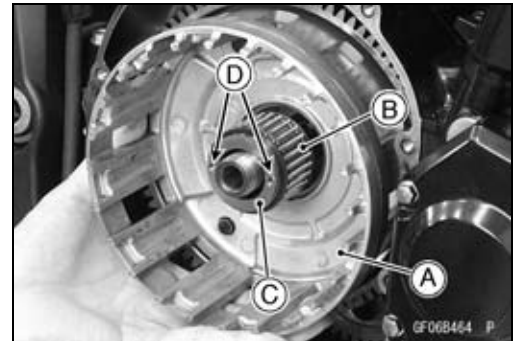

- Install the following parts to the drive shaft.
 - Spacer ($\phi 47 \times \phi 25.5$) [A]
 - Clutch Hub



- Install the washer [A] so that the "OUTSIDE" mark [B] faces outward.

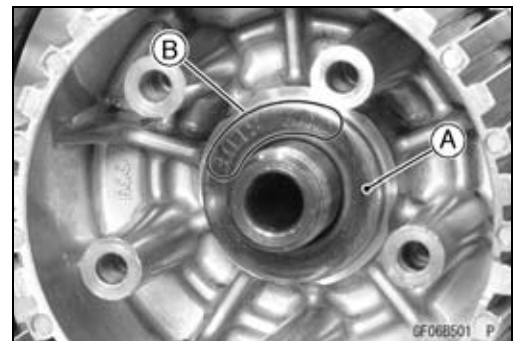

- Replace the clutch hub nut with a new one.
- Holding the clutch hub, tighten the clutch hub nut.

Special Tool - Clutch Holder: 57001-1243

Torque - Clutch Hub Nut: 135 N·m (13.8 kgf·m, 99.6 ft·lb)

- Install the spring seat [A] and spring [B] as shown in the figure.
 - Clutch Hub [C]

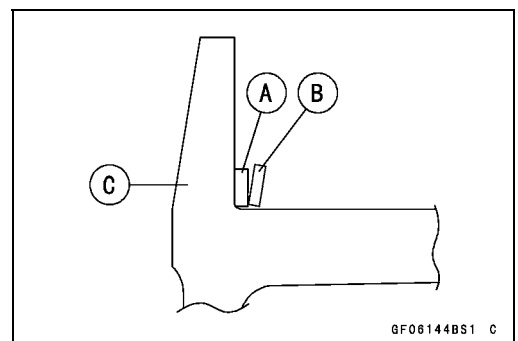

6-12 CLUTCH

Clutch

- Install the friction plates and steel plates, starting with a friction plate and alternating them.

NOTE

- Install the both ends marked two friction plates at disassembled to the their original position.
- When replace the friction plates with new ones, mark the both ends two friction plates so that the two kinds of friction plates do not mix up at opening the package.

NOTICE

If new dry friction plates and steel plates are installed, apply engine oil to the surfaces of each plate to avoid clutch plate seizure.

- Install the last friction plate [A] fitting the tangs in the grooves in the housing as shown in the figure.
- Apply molybdenum disulfide grease to the pusher shaft [A].
- Apply engine oil to the needle bearing [B].
- Install the pusher [C], needle bearing and washer [D] in the clutch spring plate [E].

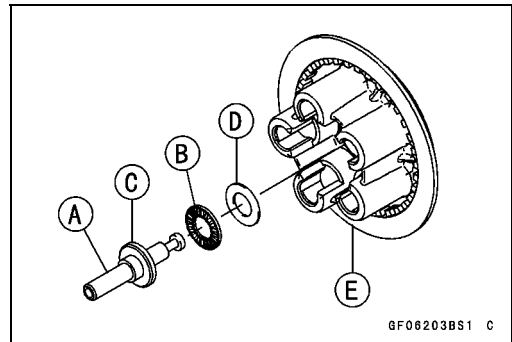

- Install the clutch spring plate so that there are no gap [A].
- ★ If it has gap [B], turn the clutch spring plate to install it again.
 - [C] Correct
 - [D] Wrong
- Install:
 - Clutch Springs
- Tighten:
 - Torque - Clutch Spring Bolts: 9.0 N·m (0.90 kgf·m, 80 in·lb)**
- Install the clutch cover (see Clutch Cover Installation).

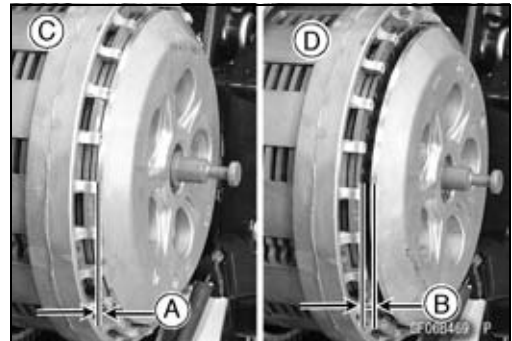

Clutch

Clutch Plate Assembly Inspection

- Inspect the friction plate thickness (see Clutch Plate, Wear, Damage Inspection).
- Measure the length [A] of the clutch plate assembly as shown in the figure.

○ Assemble:

- Clutch Hub [B]
- Spring Seat [C]
- Spring [D]
- Friction Plates [E]
- Steel Plates [F]
- Clutch Spring Plate [G]
- Clutch Springs [H]
- Clutch Spring Bolts [I]

NOTE

○ Install the both ends marked two friction plates at disassembled to the their original position.

Torque - Clutch Spring Bolts: 9.0 N·m (0.90 kgf·m, 80 in·lb)

Clutch Plate Assembly Length

Standard: 51.1 ~ 51.7 mm (2.01 ~ 2.04 in.)

- ★ If the length is not within the specified range, adjust the length (see Clutch Plate Assembly Adjustment).

Clutch Plate Assembly Adjustment

- Inspect the clutch plate assembly length, and then replace the steel plate(s) which brings the length within the specified range.

● Remove:

- Clutch Spring Bolts
- Clutch Springs
- Clutch Spring Plate

● Replace the following steel plate(s).

Thickness	Part Number
2.3 mm (0.091 in.)	13089-0008
2.6 mm (0.102 in.)	13089-0009
2.9 mm (0.114 in.)	13089-1093

NOTE

○ Do not use the steel plate of 2.3 mm (0.091 in.) and 2.9 mm (0.114 in.) thickness at the same time.

- Install the removed parts, and inspect the clutch plate assembly length.

Torque - Clutch Spring Bolts: 9.0 N·m (0.90 kgf·m, 80 in·lb)

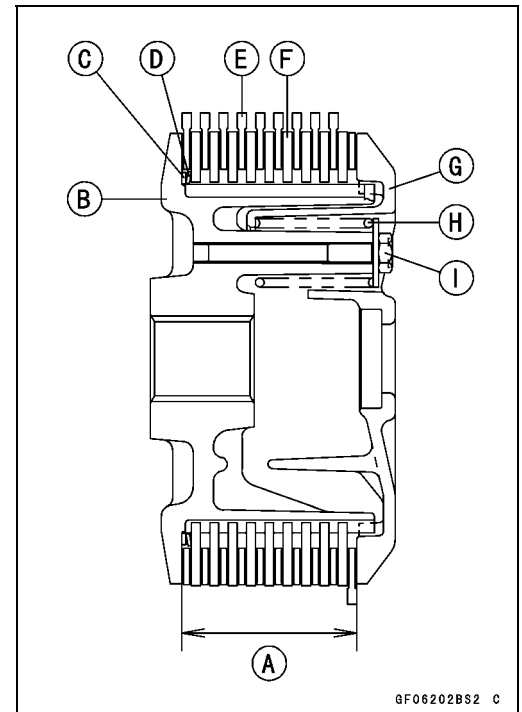

6-14 CLUTCH

Clutch

Clutch Plate, Wear, Damage Inspection

- Visually inspect the friction and steel plates for signs of seizure, overheating (discoloration), or uneven wear.
- Measure the thickness of each friction plate [A] at several points.
- ★ If any plates show signs of damage, or if they have worn past the service limit, replace them with new ones.

Friction Plate Thickness

Standard: 2.72 ~ 2.88 mm (0.107 ~ 0.113 in.)

Service Limit: 2.4 mm (0.094 in.)

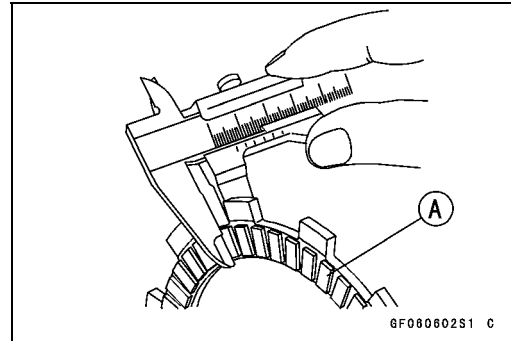

Clutch Plate Warp Inspection

- Place each friction plate or steel plate on a surface plate and measure the gap between the surface plate [A] and each friction plate or steel plate [B] with a thickness gauge [C]. The gap is the amount of friction or steel plate warp.
- ★ If any plate is warped over the service limit, replace it with a new one.

Friction and Steel Plate Warp

Standard: 0.15 mm (0.0059 in.) or less

Service Limit: 0.3 mm (0.012 in.)

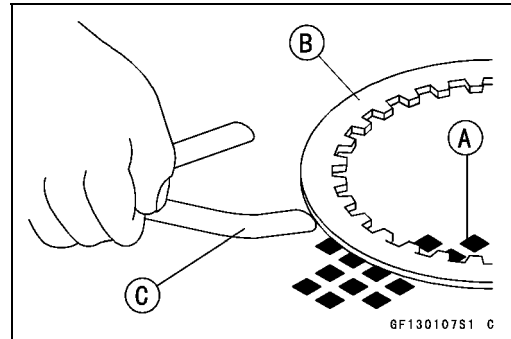

Clutch Spring Free Length Measurement

- Measure the free length of the clutch springs [A].
- ★ If any spring is shorter than the service limit, it must be replaced.

Clutch Spring Free Length

Standard: 64.8 mm (2.55 in.)

Service Limit: 61.8 mm (2.43 in.)

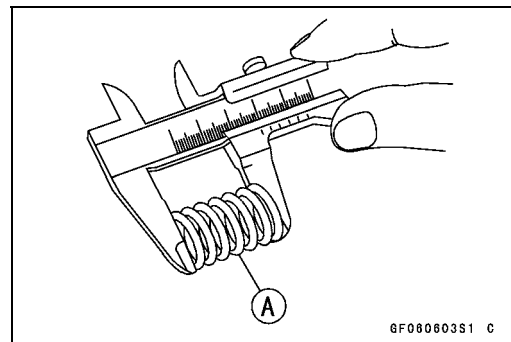

Clutch Housing Finger Inspection

- Visually inspect the clutch housing fingers [A] where the friction plate tangs [B] hit them.
- ★ If they are badly worn or if there are groove cuts where the tangs hit, replace the housing. Also, replace the friction plates if their tangs are damaged.

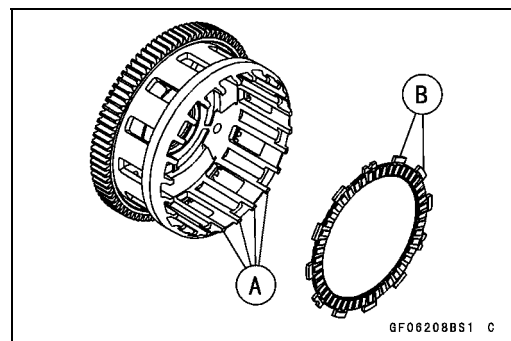

Clutch Housing Spline Inspection

- Visually inspect where the teeth [A] on the steel plates wear against the clutch hub splines [B].
- ★ If there are notches worn into the splines, replace the clutch hub. Also, replace the steel plates if their teeth are damaged.

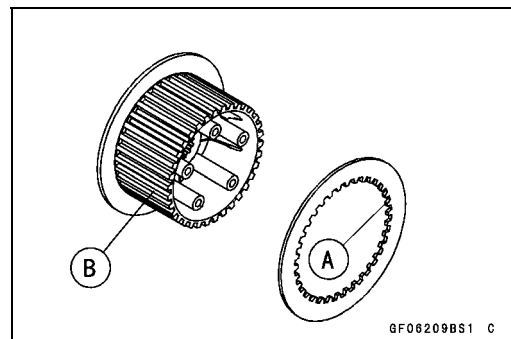

Engine Lubrication System

Table of Contents

Exploded View.....	7-2
Engine Oil Flow Chart.....	7-4
Specifications	7-5
Special Tools and Sealants	7-6
Engine Oil and Oil Filter.....	7-7
Oil Level Inspection.....	7-7
Engine Oil Change.....	7-7
Oil Filter Replacement	7-7
Oil Pan.....	7-8
Oil Pan Removal	7-8
Oil Pan Installation	7-8
Oil Screen.....	7-10
Oil Screen Removal	7-10
Oil Screen Installation	7-10
Oil Screen Cleaning.....	7-10
Oil Pressure Relief Valve.....	7-11
Oil Pressure Relief Valve Removal.....	7-11
Oil Pressure Relief Valve Installation	7-11
Oil Pressure Relief Valve Inspection.....	7-11
Oil Pump.....	7-12
Oil Pump Removal	7-12
Oil Pump Installation	7-12
Oil Pump Drive Gear Removal.....	7-13
Oil Pump Drive Gear Installation.....	7-13
Oil Cooler.....	7-14
Oil Cooler Removal.....	7-14
Oil Cooler Installation.....	7-14
Oil Pressure Measurement.....	7-15
Oil Pressure Measurement	7-15
Oil Pressure Switch	7-16
Oil Pressure Switch Removal	7-16
Oil Pressure Switch Installation	7-16
Oil Pipe.....	7-17
Oil Pipe Removal	7-17
Oil Pipe Installation	7-17

7-2 ENGINE LUBRICATION SYSTEM

Exploded View

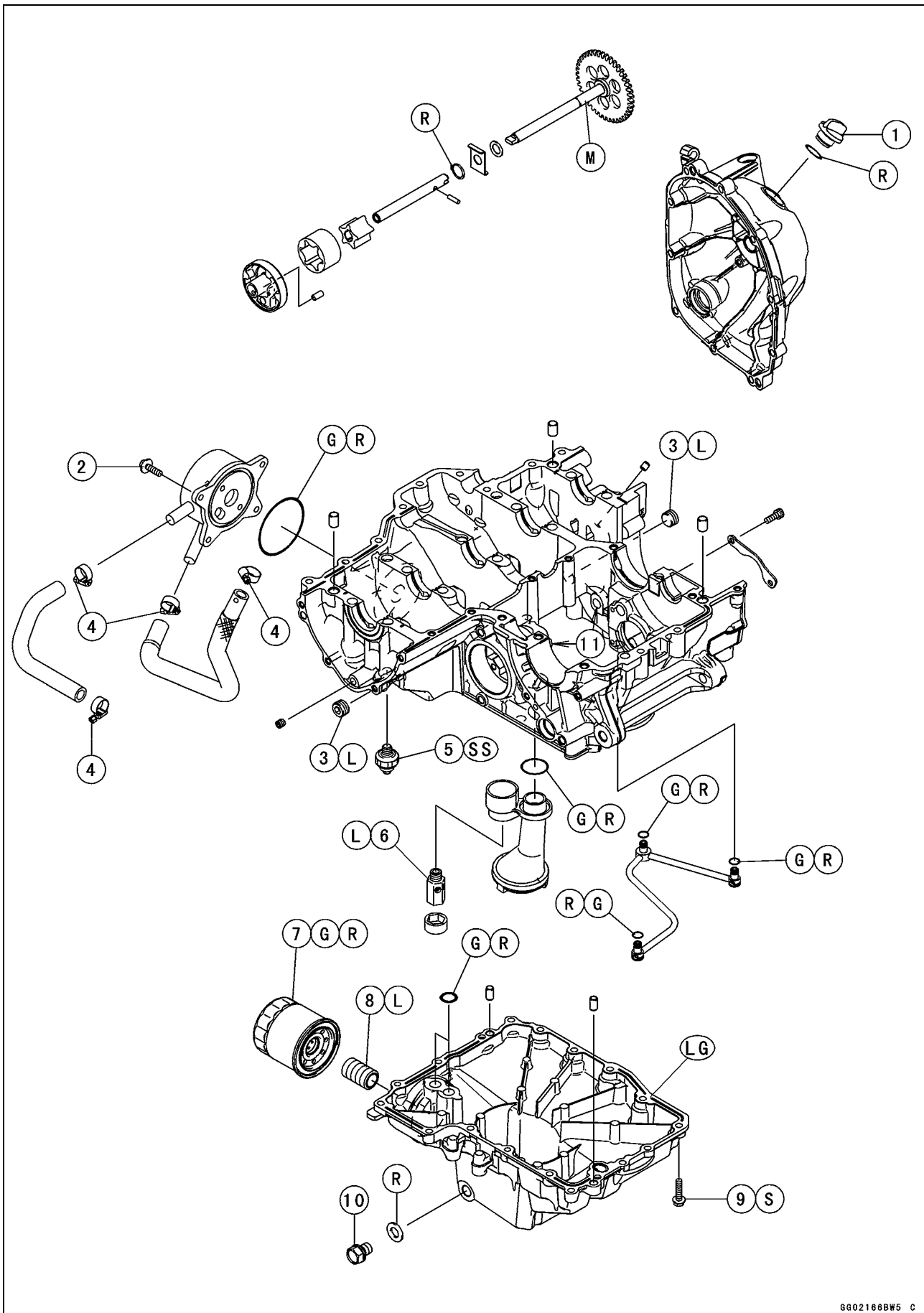

ENGINE LUBRICATION SYSTEM 7-3

Exploded View

No.	Fastener	Torque			Remarks
		N·m	kgf·m	ft·lb	
1	Oil Filler Plug	2.0	0.20	18 in·lb	
2	Oil Cooler Bolts	12	1.2	106 in·lb	
3	Oil Passage Plug	20	2.0	15	L
4	Radiator (Water) Hose Clamp Screws	3.0	0.31	27 in·lb	
5	Oil Pressure Switch	15	1.5	11	SS
6	Oil Pressure Relief Valve	15	1.5	11	L
7	Oil Filter	17	1.7	13	G, R
8	Oil Filter Pipe	25	2.5	18	L
9	Oil Pan Bolts	12	1.2	106 in·lb	S
10	Engine Oil Drain Bolt	29	3.0	21	

11. Apply molybdenum disulfide oil solution to the hole of the oil pump drive gear shaft.

G: Apply grease.

L: Apply a non-permanent locking agent.

LG: Apply liquid gasket.

M: Apply molybdenum disulfide grease.

R: Replacement Parts

S: Follow the specified tightening sequence.

SS: Apply silicone sealant.

7-4 ENGINE LUBRICATION SYSTEM

Engine Oil Flow Chart

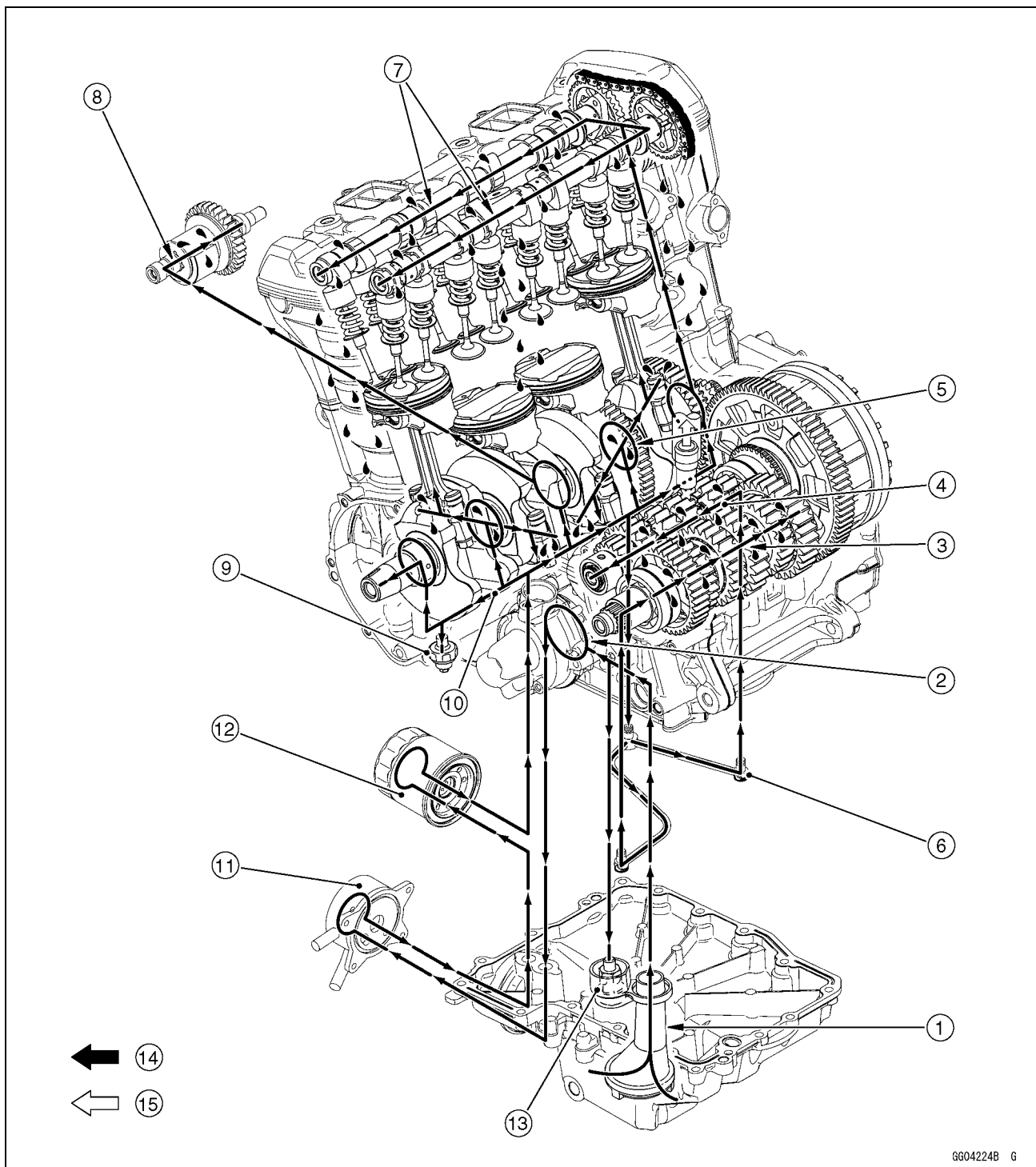

1. Oil Screen
2. Oil Pump
3. Output Shaft Oil Passage
4. Drive Shaft Oil Passage
5. Crankshaft Oil Passage
6. Oil Pipe
7. Camshaft Oil Passage
8. Balancer Oil Passage

9. Oil Pressure Switch
10. Main Oil Passage
11. Oil Cooler
12. Oil Filter
13. Oil Pressure Relief Valve
14. Oil
15. Blowby Gas

ENGINE LUBRICATION SYSTEM 7-5

Specifications

Item	Standard
Engine Oil Type Viscosity Capacity: Level	API SG, SH, SJ, SL or SM with JASO MA, MA1 or MA2 SAE 10W-40 3.2 L (3.4 US qt) (when filter is not removed) 3.8 L (4.0 US qt) (when filter is removed) 4.0 L (4.2 US qt) (when engine is completely dry) Between upper and lower level lines (Wait several minutes after idling or running)
Oil Pressure Measurement Oil Pressure	255 ~ 304 kPa (2.6 ~ 3.1 kgf/cm ² , 37 ~ 44 psi) at 4 000 r/min (rpm), Oil Temperature 50°C (122°F)

7-6 ENGINE LUBRICATION SYSTEM

Special Tools and Sealants

**Liquid Gasket, TB1211:
56019-120**

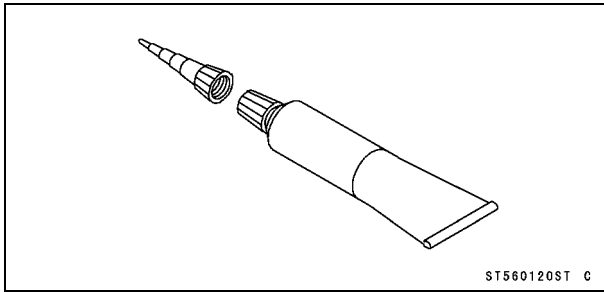

**Oil Pressure Gauge Adapter, PT3/8:
57001-1233**

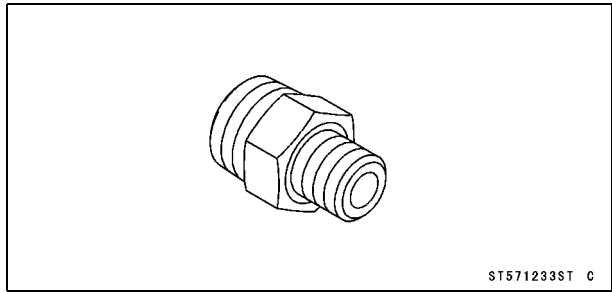

**Outside Circlip Pliers:
57001-144**

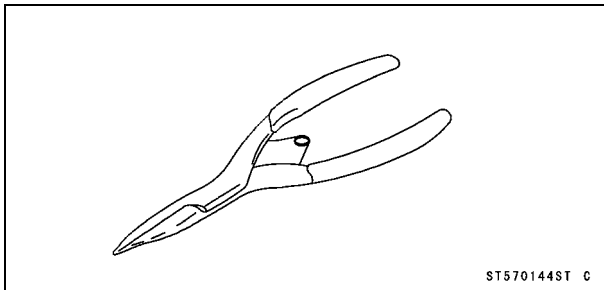

**Liquid Gasket, TB1207B:
92104-2068**

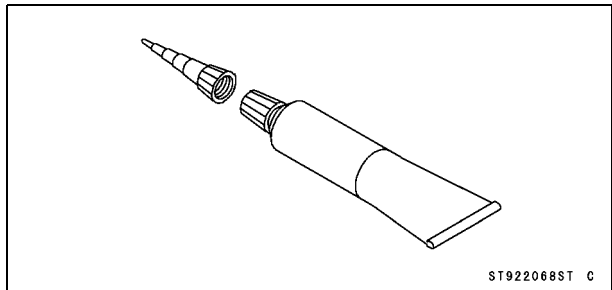

**Oil Pressure Gauge, 10 kgf/cm²:
57001-164**

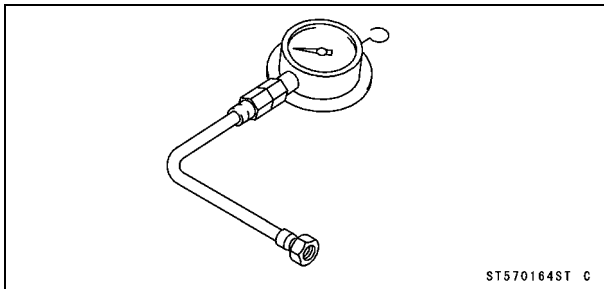

Engine Oil and Oil Filter

⚠ WARNING

Vehicle operation with insufficient, deteriorated, or contaminated engine oil will cause accelerated wear and may result in engine seizure, accident, and injury. Check the oil level before each use and change the oil and filter according to the periodic maintenance chart.

Oil Level Inspection

- Check that the engine oil level is between the upper [A] and lower [B] levels in the gauge.

NOTE

- Situate the motorcycle so that it is perpendicular to the ground.
- If the motorcycle has just been used, wait several minutes for all the oil to drain down.
- If the oil has just been changed, start the engine and run it for several minutes at idle speed. This fills the oil filter with oil. Stop the engine, then wait several minutes until the oil settles.

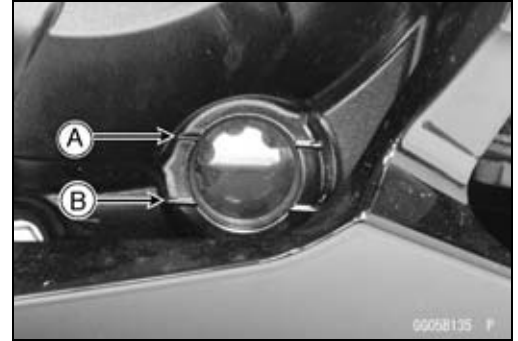

NOTICE

Racing the engine before the oil reaches every part can cause engine seizure.

If the engine oil gets extremely low or if the oil pump or oil passages clog up or otherwise do not function properly, the warning indicator light (LED) and oil pressure warning symbol will blink. If this blink stays on when the engine is running above idle speed, stop the engine immediately and find the cause.

- ★ If the oil level is too high, remove the excess oil, using a syringe or some other suitable device.
- ★ If the oil level is too low, add the correct amount of oil through the oil filler opening. Use the same type and make of oil that is already in the engine.

NOTE

- If the engine oil type and make are unknown, use any brand of the specified oil to top off the level in preference to running the engine with the oil level low. Then at your earliest convenience, change the oil completely.

Engine Oil Change

- Refer to the Engine Oil Change in the Periodic Maintenance chapter.

Oil Filter Replacement

- Refer to the Oil Filter Replacement in the Periodic Maintenance chapter.

7-8 ENGINE LUBRICATION SYSTEM

Oil Pan

Oil Pan Removal

- Remove:
 - Exhaust Pipe (see Exhaust Pipe Removal in the Engine Top End chapter)
 - Oil Filter (see Oil Filter Replacement in the Periodic Maintenance chapter)
 - Oil Pan Bolts [A]
 - Oil Pan [B]
- Remove the following parts if necessary.
 - Oil Screen (see Oil Screen Removal)
 - Oil Pipe (see Oil Pipe Removal)
 - Oil Pressure Relief Valve (see Oil Pressure Relief Valve Removal)

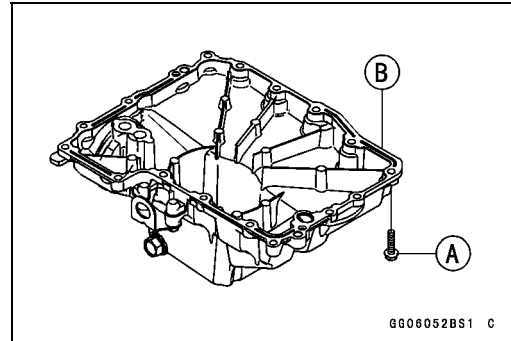

Oil Pan Installation

- Install the following parts if removed.
 - Oil Pressure Relief Valve (see Oil Pressure Relief Valve Installation)
 - Oil Pipe (see Oil Pipe Installation)
 - Oil Screen (see Oil Screen Installation)
- Replace the O-rings [A] with new ones.
- Apply grease to the O-rings, and install them.
- Install the dowel pins [B].

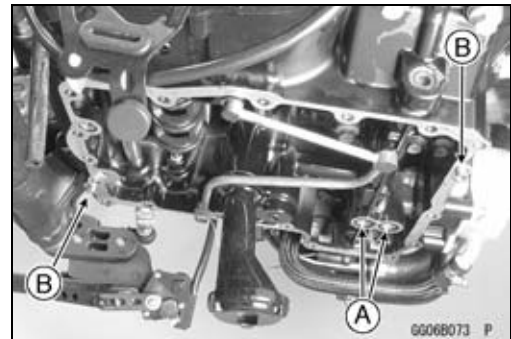

- Apply liquid gasket [A] to the mating surface of the oil pan.
- Using a high-flash point solvent, clean off any oil or dirt that may be on the liquid gasket coating area. Dry them with a clean cloth.

Sealant - Liquid Gasket, TB1207B: 92104-2068

NOTE

- Especially, apply liquid gasket so that it shall be filled up on the grooves [B].

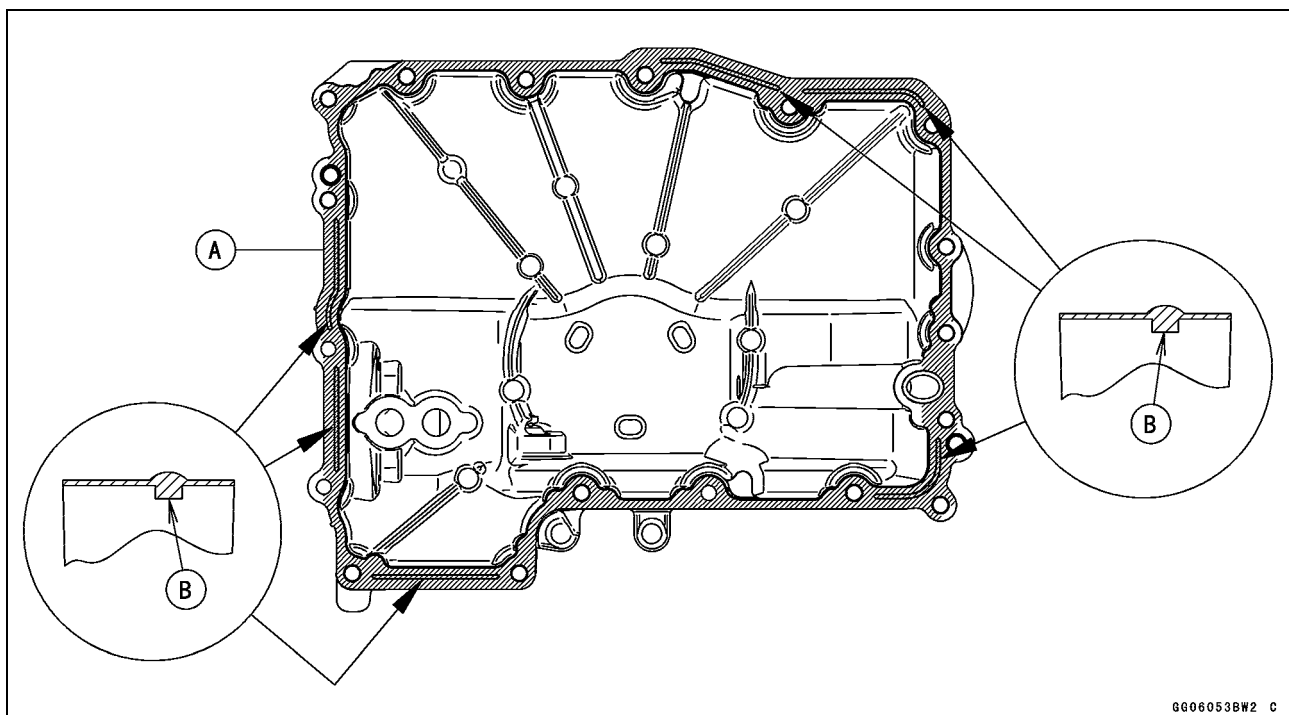

Oil Pan

NOTE

- Make the application finish within 7 minutes when the liquid gasket to the mating surface of the oil pan is applied.
- Moreover fit the oil pan and tighten the bolts just after application of the liquid gasket.
- Tighten the oil pan bolts following sequence [1 ~ 20].
Torque - Oil Pan Bolts: 12 N·m (1.2 kgf·m, 106 in·lb)

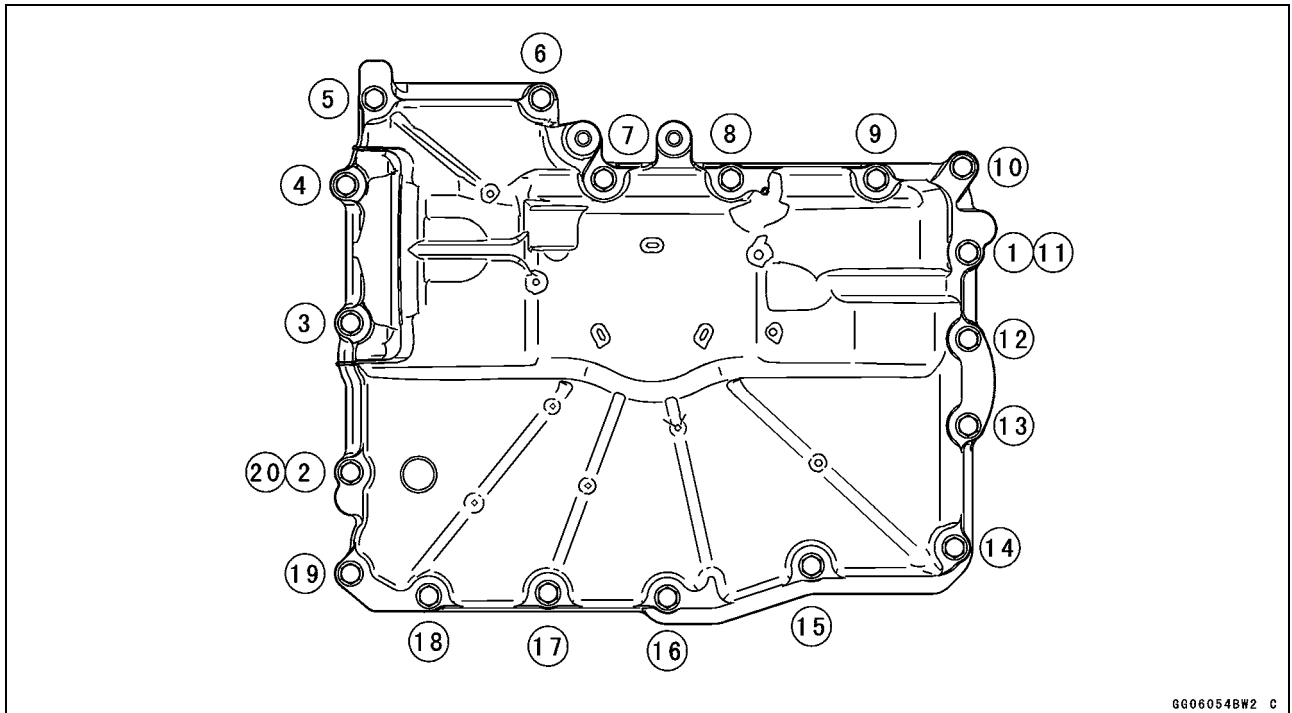

- Install the removed parts (see appropriate chapters).

7-10 ENGINE LUBRICATION SYSTEM

Oil Screen

Oil Screen Removal

- Remove:
 - Oil Pan (see Oil Pan Removal)
 - Oil Screen [A]

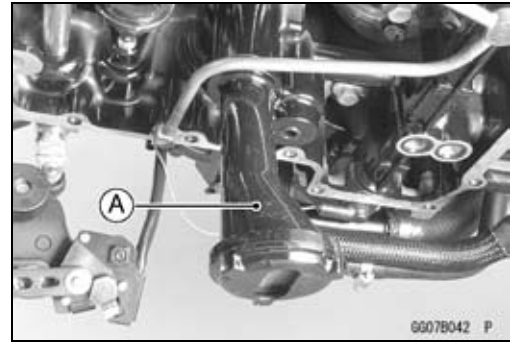

Oil Screen Installation

- Clean the oil screen (see Oil Screen Cleaning).
- Replace the O-ring [A] with a new one, and install it.
- Apply grease to the O-ring.
- Install the rubber damper [B] to the oil pressure relief valve.
- Install the oil screen.

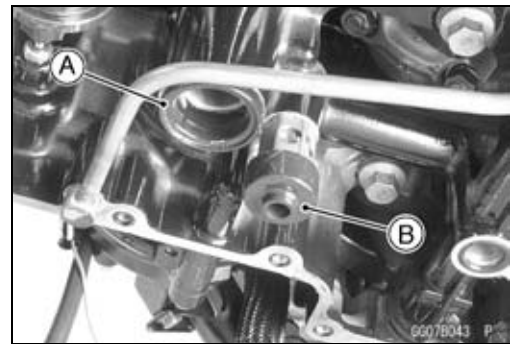

Oil Screen Cleaning

- Remove the oil screen (see Oil Screen Removal).
- Clean the oil screen with a high-flash point solvent and remove the particles stuck.
- Blow away the particles by applying compressed air [A] from the inside to the outside (from the clean side to the dirty side).



⚠ WARNING

Gasoline and low-flash point solvents can be flammable and/or explosive and cause severe burns. Clean the screen in a well-ventilated area, and take care that there are no sparks or flame anywhere near the working area; this includes any appliance with a pilot light. Do not use gasoline or a low-flash point solvent to clean the screen.

NOTE

○ *While cleaning the screen, check for any metal particles that might indicate internal engine damage.*

- Check the screens carefully for any damage.
- ★ If the screen is damaged, replace the oil screen.

Oil Pressure Relief Valve

Oil Pressure Relief Valve Removal

- Remove:
 - Oil Screen (see Oil Screen Removal)
 - Oil Pressure Relief Valve [A]

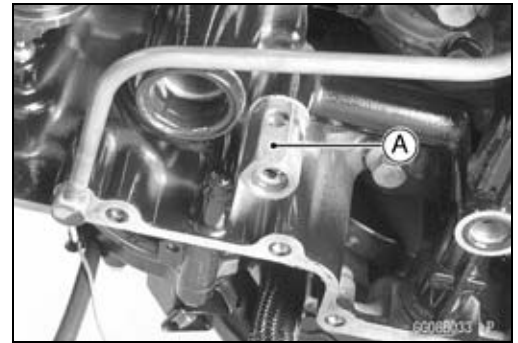

Oil Pressure Relief Valve Installation

- Apply a non-permanent locking agent to the threads of the oil pressure relief valve, and tighten it.
 - Torque - Oil Pressure Relief Valve: 15 N·m (1.5 kgf·m, 11 ft·lb)

Oil Pressure Relief Valve Inspection

- Check to see if the valve [A] slides smoothly when pushing it in with a wooden or other soft rod, and see if it comes back to its seat by spring [B] pressure.

NOTE

○ Inspect the valve in its assembled state. Disassembly and assembly may change the valve performance.

- ★ If any rough spots are found during above inspection, wash the valve clean with a high-flash point solvent and blow out any foreign particles that may be in the valve with compressed air.

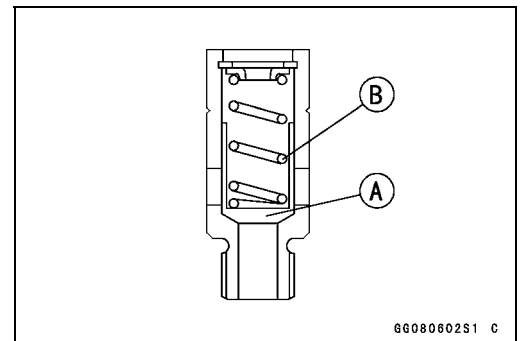

⚠ WARNING

Gasoline and low-flash point solvents can be flammable and/or explosive and cause severe burns. Clean the oil pressure relief valve in a well-ventilated area, and take care that there are no sparks or flame anywhere near the working area; this includes any appliance with a pilot light. Do not use gasoline or a low-flash point solvent to clean the oil pressure relief valve.

- ★ If cleaning does not solve the problem, replace the oil pressure relief valve as an assembly. The oil pressure relief valve is precision made with no allowance for replacement of individual parts.

7-12 ENGINE LUBRICATION SYSTEM

Oil Pump

Oil Pump Removal

- Remove:
 - Water Pump (see Water Pump Removal in the Cooling System chapter)
 - Oil Pump Cover [A]

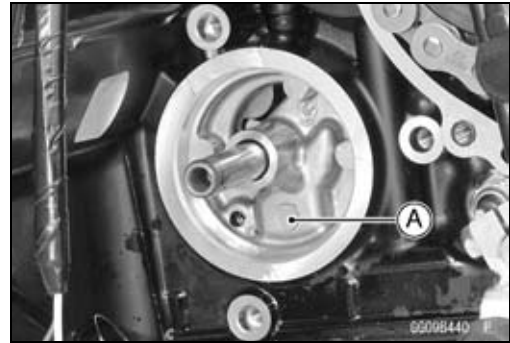

- Remove:
 - Oil (Water) Pump Shaft [A] with Inner Rotor [B]
 - Outer Rotor [C]

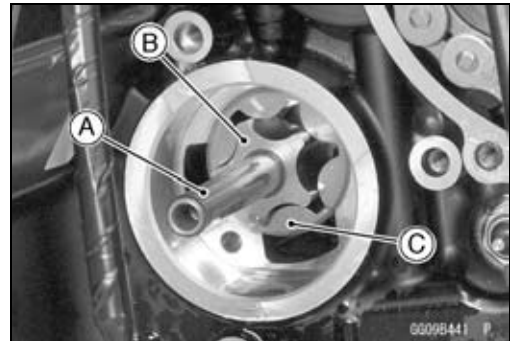

Oil Pump Installation

- Install the outer rotor [A] into the crankcase.

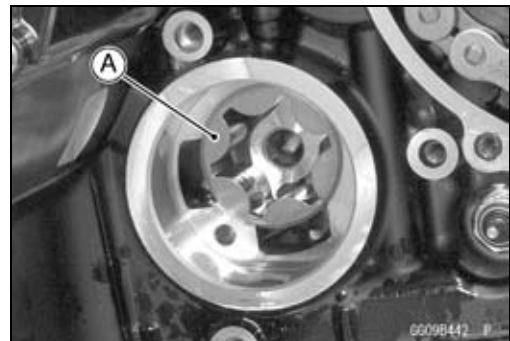

- Assemble the pin [A], inner rotor [B] and oil (water) pump shaft [C].

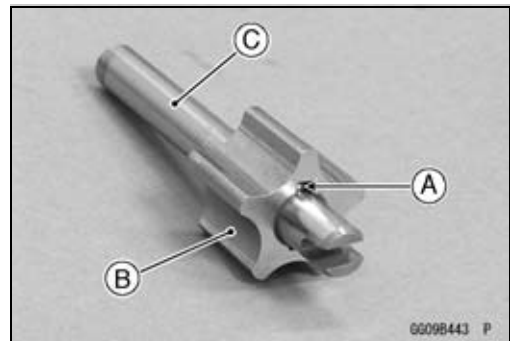

- Turn the pump shaft so that the slot [A] in its shaft fits onto the projection [B] of the pump drive gear shaft.

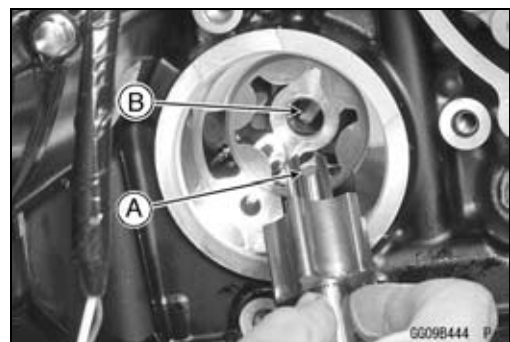

Oil Pump

- Install the dowel pin [A].
- Install the oil pump cover [B] so that the dowel pin fits into the hole [C] of the oil pump cover.
- Install the water pump (see Water Pump Installation in the Cooling System chapter).

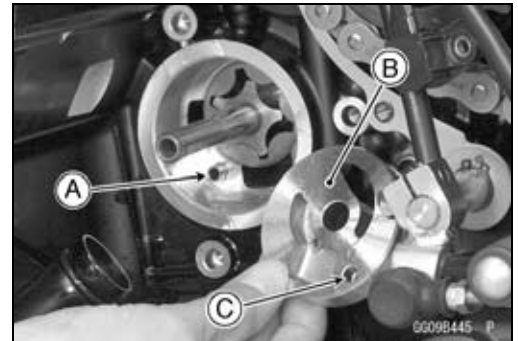

Oil Pump Drive Gear Removal

- Remove:
 - Clutch (see Clutch Removal in the Clutch chapter)
 - Oil Pan (see Oil Pan Removal)
 - Circlip [A] and Washer [B]

Special Tool - Outside Circlip Pliers: 57001-144

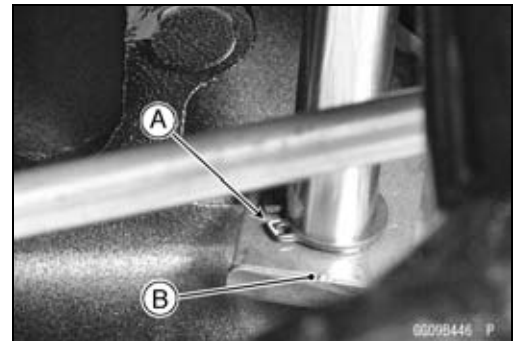

- Remove:
 - Oil Pump Drive Gear [A]
 - Washer [B]

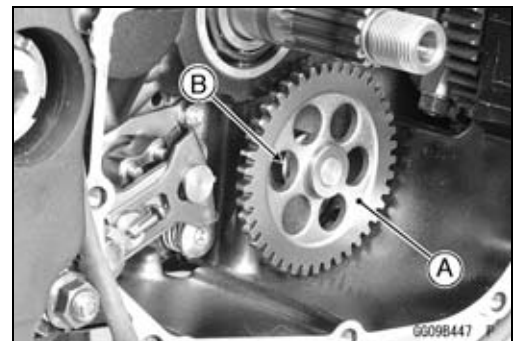

Oil Pump Drive Gear Installation

- Apply molybdenum disulfide oil solution to the hole of the oil pump drive gear shaft in the crankcase.
- Apply molybdenum grease to the journal portion [A] on the oil pump drive gear shaft [B].
- Install the washer [C] to the shaft.

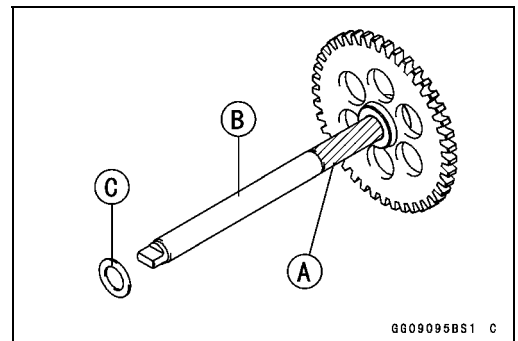

- Replace the circlip [A] with a new one.
- Insert the oil pump drive gear to the lower crankcase.
- Install the washer [B] and circlip.

Special Tool - Outside Circlip Pliers: 57001-144

- Fit the projection on the shaft and oil (water) pump shaft slot.
- Set the circlip original position.

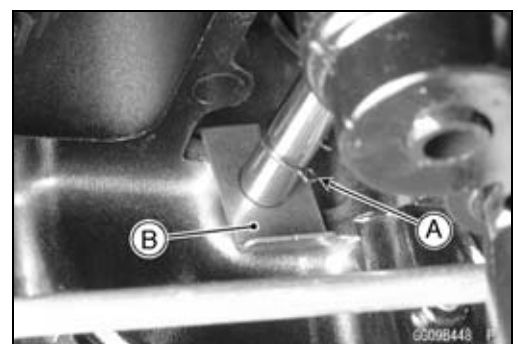

7-14 ENGINE LUBRICATION SYSTEM

Oil Cooler

Oil Cooler Removal

- Remove:
 - Left Lower Fairing Assembly (see Lower Fairing Assembly Removal in the Frame chapter)
 - Coolant (Drain, see Coolant Change in the Periodic Maintenance chapter)
 - Engine Oil (Drain, see Engine Oil Change in the Periodic Maintenance chapter)
 - Water Hose Clamp Screws (Loosen) [A]
 - Water Hoses [B]
 - Oil Cooler Bolts [C]
 - Oil Cooler [D]

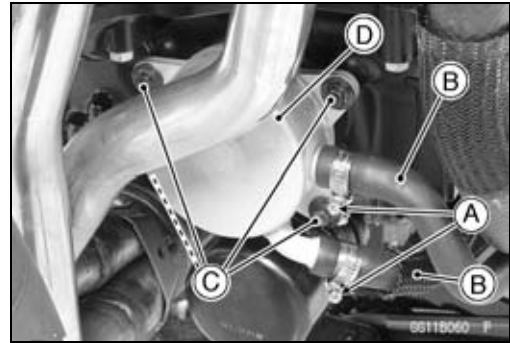

Oil Cooler Installation

- Replace the O-ring [A] with a new one.
- Apply grease to the O-ring and install it.
- Install the oil cooler.
- Tighten:
 - Torque - Oil Cooler Bolts: 12 N·m (1.2 kgf·m, 106 in·lb)**

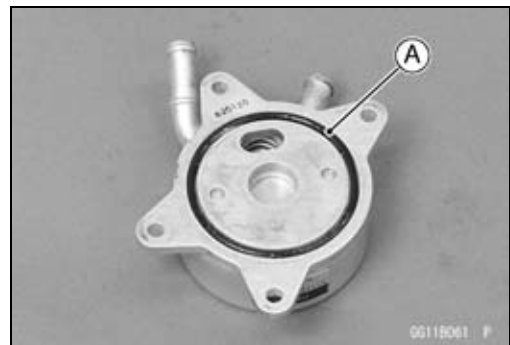

- Install the water hoses [A] and clamps as shown in the figure.
- Tighten:
 - Torque - Radiator (Water) Hose Clamp Screws [B]: 3.0 N·m (0.31 kgf·m, 27 in·lb)**
- Install the removed parts (see appropriate chapters).

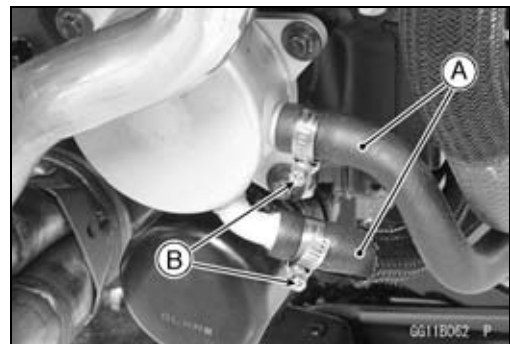

Oil Pressure Measurement

Oil Pressure Measurement

- Remove the right lower fairing (see Lower Fairing Removal in the Frame chapter).
- Remove the oil passage plug [A].

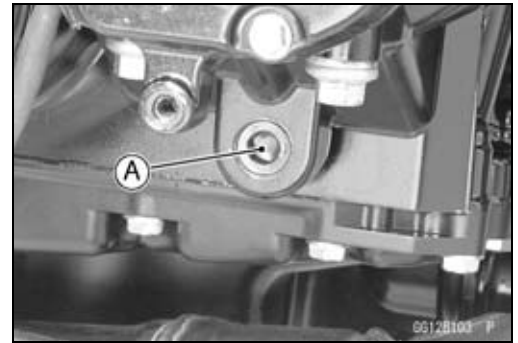

- Attach the adapter [A] and gauge [B] to the plug hole.

Special Tools - Oil Pressure Gauge, 10 kgf/cm²: 57001-164
Oil Pressure Gauge Adapter, PT3/8: 57001-1233

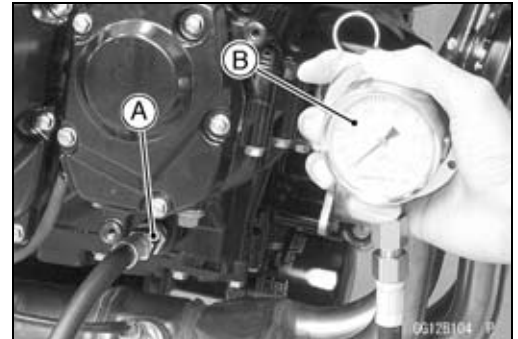

- Start the engine and warm up the engine.
- Run the engine at the specified speed, and read the oil pressure gauge.
- ★ If the oil pressure is much lower than the standard, check the oil pump, relief valve, and/or crankshaft bearing insert wear immediately.
- ★ If the reading is much higher than the standard, check the oil passages for clogging.

Oil Pressure

Standard: 255 ~ 304 kPa (2.6 ~ 3.1 kgf/cm², 37 ~ 44 psi) at 4 000 r/min (rpm), oil temperature 50°C (122°F)

- Stop the engine.
- Remove the oil pressure gauge and adapter.

⚠ WARNING

Take care against burns from hot engine oil that will drain through the oil passage when the gauge adapter is removed.

- Apply a non-permanent locking agent to the oil passage plug, and tighten it.

Torque - Oil Passage Plug: 20 N·m (2.0 kgf·m, 15 ft·lb)

7-16 ENGINE LUBRICATION SYSTEM

Oil Pressure Switch

Oil Pressure Switch Removal

- Remove:
 - Left Lower Fairing Assembly (see Lower Fairing Assembly Removal in the Frame chapter)
 - Engine Oil (Drain, see Engine Oil Change in the Periodic Maintenance chapter)
 - Switch Cover [A]
 - Switch Terminal Bolt [B]
 - Oil Pressure Switch [C]

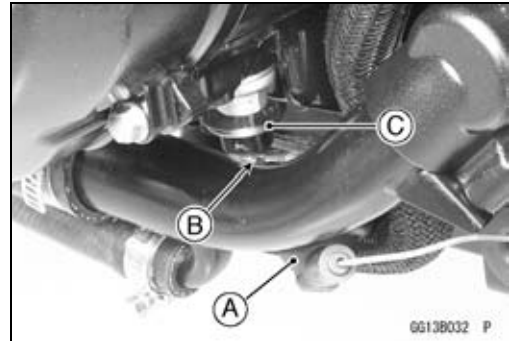

Oil Pressure Switch Installation

- Apply silicone sealant to the threads of the oil pressure switch and tighten it.
- Using a high-flash point solvent, clean off any oil or dirt that may be on the liquid gasket coating area. Dry them with a clean cloth.
 - Sealant - Liquid Gasket, TB1211: 56019-120**
 - Torque - Oil Pressure Switch: 15 N·m (1.5 kgf·m, 11 ft·lb)**
- Install the switch lead.
- Tighten:
 - Torque - Oil Pressure Switch Terminal Bolt: 2.0 N·m (0.20 kgf·m, 18 in·lb)**
- Apply grease to the terminal.

Oil Pipe

Oil Pipe Removal

- Remove:
 - Oil Pan (see Oil Pan Removal)
 - Oil Pipe [A]

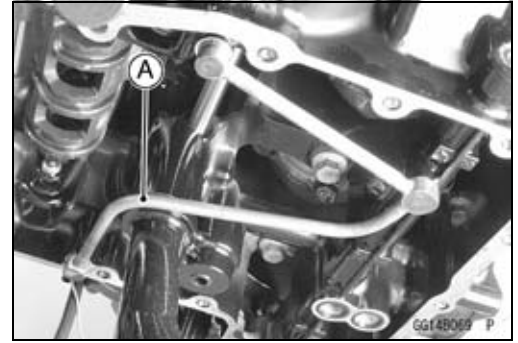

Oil Pipe Installation

- Replace the O-rings [A] with new ones.
- Apply grease to the O-rings, and install them.

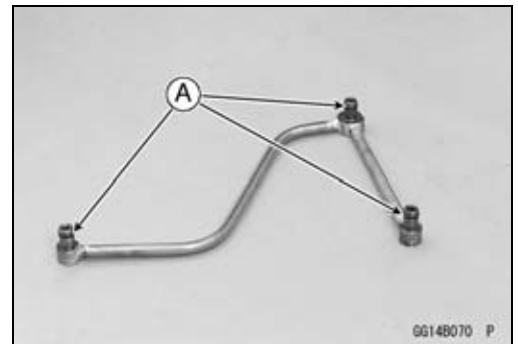

Engine Removal/Installation

Table of Contents

Exploded View.....	8-2
Special Tool	8-4
Engine Removal/Installation	8-5
Engine Removal.....	8-5
Engine Installation.....	8-8

8-2 ENGINE REMOVAL/INSTALLATION

Exploded View

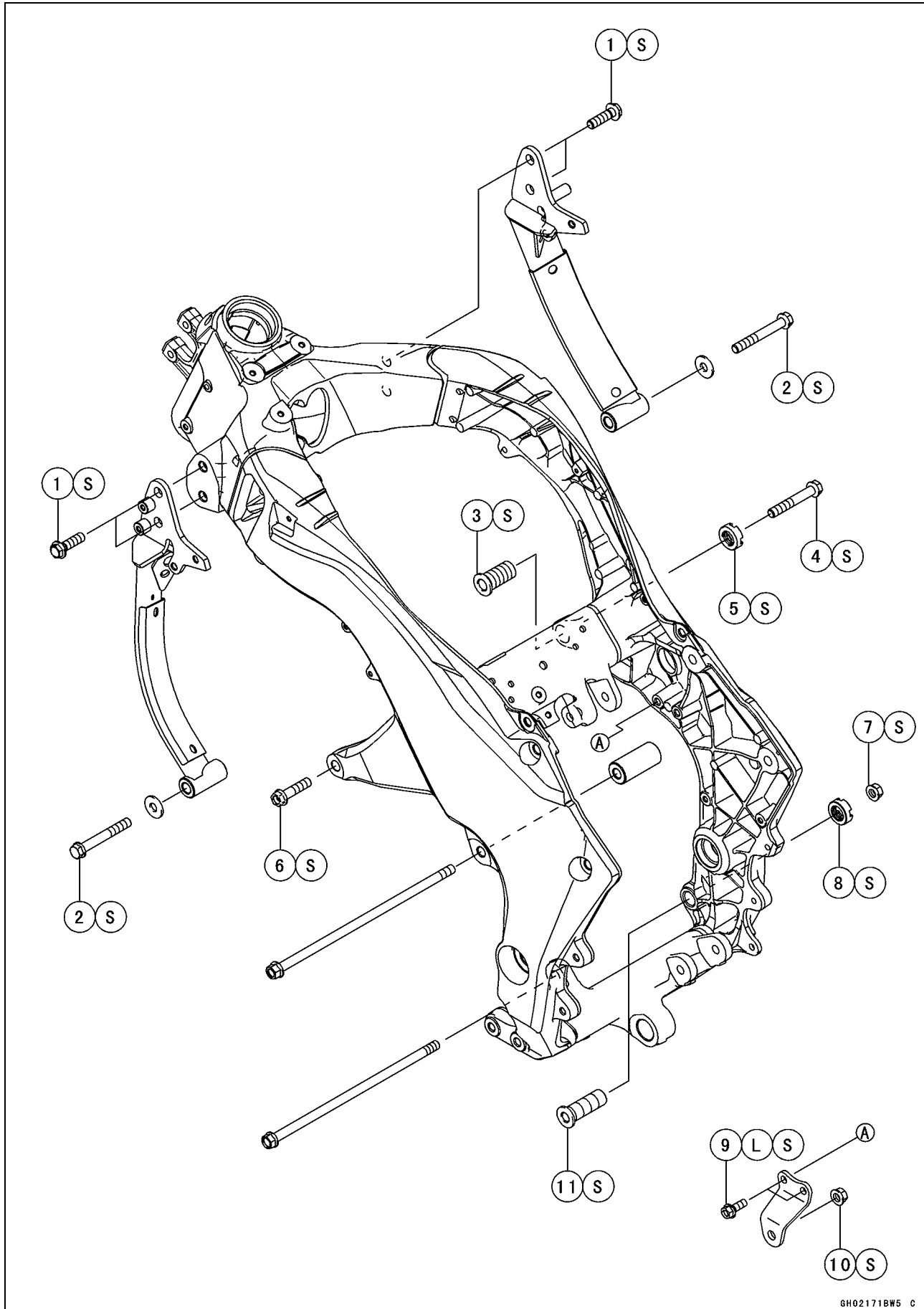

ENGINE REMOVAL/INSTALLATION 8-3

Exploded View

No.	Fastener	Torque			Remarks
		N·m	kgf·m	ft·lb	
1	Upper Engine Bracket Bolts	44	4.5	32	S
2	Lower Engine Bracket Bolts	59	6.0	44	S
3	Upper Adjusting Collar	9.8	1.0	87 in·lb	S
4	Upper Engine Mounting Bolt (L = 65)	44	4.5	32	S
5	Upper Adjusting Collar Locknut	49	5.0	36	S
6	Upper Engine Mounting Bolt (L = 40)	44	4.5	32	S
7	Lower Engine Mounting Nut	44	4.5	32	S
8	Lower Adjusting Collar Locknut	49	5.0	36	S
9	Middle Engine Bracket Bolts	25	2.5	18	L, S
10	Middle Engine Mounting Nut	44	4.5	32	S
11	Lower Adjusting Collar	9.8	1.0	87 in·lb	S

L: Apply a non-permanent locking agent.

S: Follow the specified tightening sequence.

8-4 ENGINE REMOVAL/INSTALLATION

Special Tool

Engine Mount Nut Wrench:

57001-1450

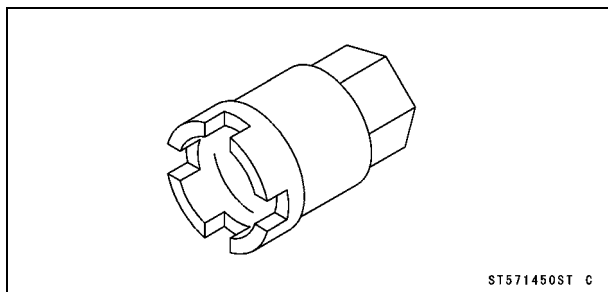

Engine Removal/Installation

Engine Removal

- Support the rear part of the swingarm with a stand.
- Squeeze the brake lever slowly and hold it with a band [A].

⚠ WARNING

Motorcycle may fall over unexpectedly resulting in an accident or injury. Be sure to hold the front brake when removing the engine.

NOTICE

Be sure to hold the front brake when removing the engine, or the motorcycle may fall over. The engine or the motorcycle could be damaged.

- Remove:
 - Engine Oil (Drain, see Engine Oil Change in the Periodic Maintenance chapter)
 - Coolant (Drain, see Coolant Change in the Periodic Maintenance chapter)
 - Lower Fairing (see Lower Fairing Removal in the Frame chapter)
 - Clutch Cable Lower End (see Clutch Cable Removal in the Clutch chapter)
 - Radiator (see Radiator and Radiator Fan Removal in the Cooling System chapter)
 - Exhaust Pipe (see Exhaust Pipe Removal in the Engine Top End chapter)
 - Air Switching Valve (see Air Switching Valve Removal in the Engine Top End chapter)
 - Throttle Body Assy (see Throttle Body Assy Removal in the Fuel System (DFI) chapter)
 - Shift Lever (see Shift Pedal Removal in the Crankshaft/Transmission chapter)
 - Engine Sprocket (see Engine Sprocket Removal in the Final Drive chapter)
- Remove:
 - Clamps [A]
 - Water Hoses [B]

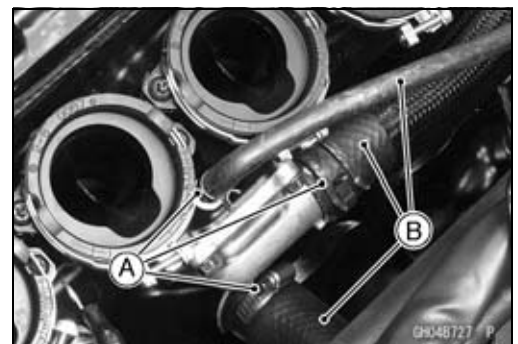
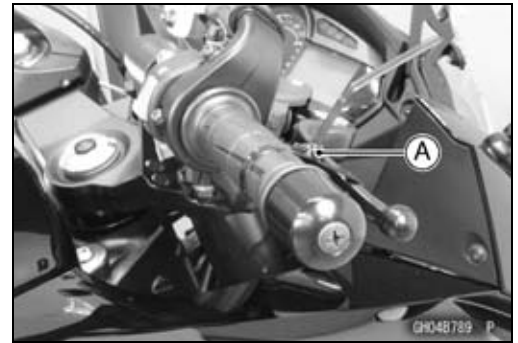

8-6 ENGINE REMOVAL/INSTALLATION

Engine Removal/Installation

- Remove the connector [A] from the bracket on the air suction valve cover.
- Disconnect the connector.
- Disconnect:
 - Starter Motor Cable (see Starter Motor Removal in the Electrical System chapter)
 - Alternator Lead Connector (see Alternator Cover Removal in the Electrical System chapter)
 - Crankshaft Sensor Lead Connector (see Crankshaft Sensor Removal in the Electrical System chapter)

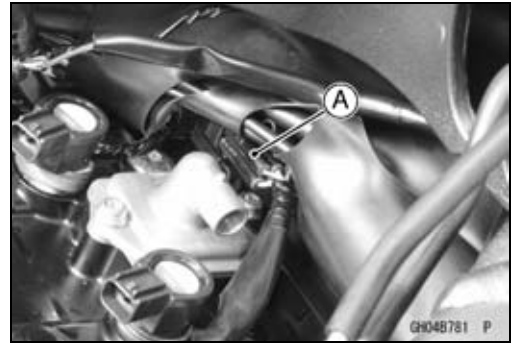

- Remove:
 - Engine Ground Cable Terminal Bolt [A]



- Remove the drive chain [A] from the output shaft [B].

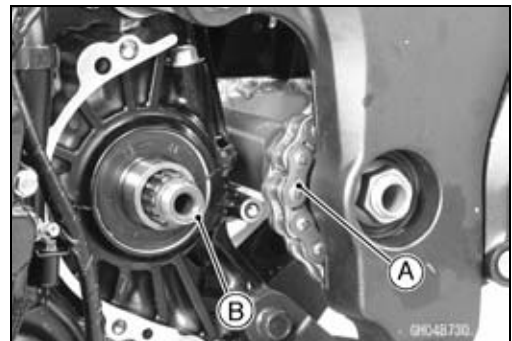

- Remove: (Both Sides)
 - Bolts [A]
 - Brackets [B]
 - Quick Rivets [C]

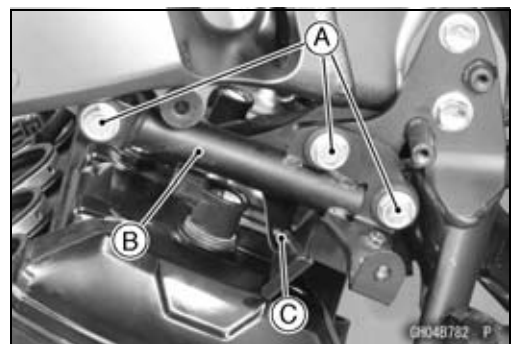

- Remove: (Left Side)
 - Upper Engine Bracket Bolts [A]
 - Lower Engine Bracket Bolt [B] and Washer
 - Engine Bracket [C]

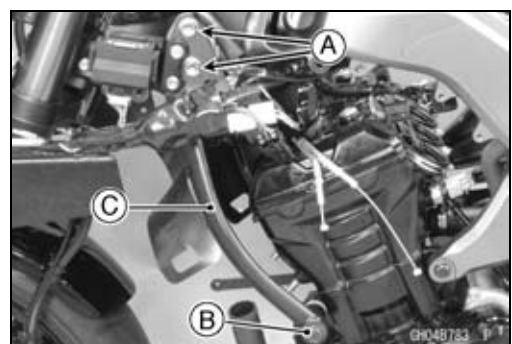

Engine Removal/Installation

- Remove: (Right Side)
Coolant Reserve Tank (see Coolant Change in the Periodic Maintenance chapter)
Upper Engine Bracket Bolts [A]
Lower Engine Bracket Bolt [B] and Washer
Engine Bracket [C]

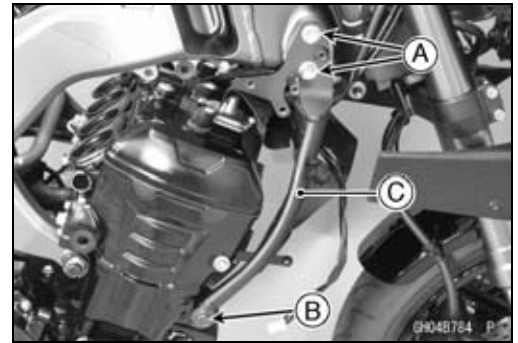

- Support the engine with a suitable stand [A].
- Put a plank [B] onto the suitable stand for engine balance.

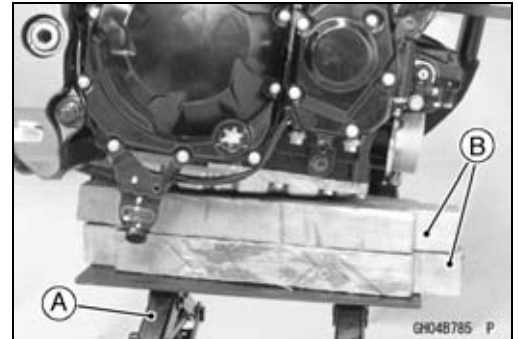

- Remove:
Upper Engine Mounting Bolt [A] (Both Sides)
Middle Engine Mounting Nut [B] and Bolt
Lower Engine Mounting Nut [C]

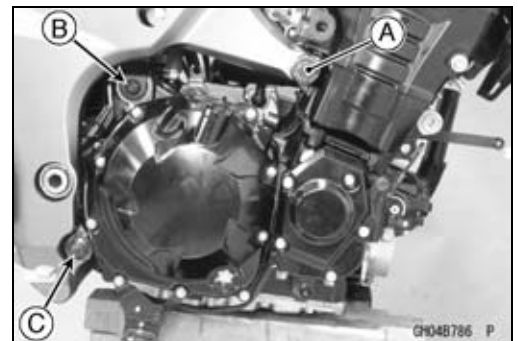

- Using the nut wrench [A], loosen the upper adjusting collar locknut [B].

Special Tool - Engine Mount Nut Wrench: 57001-1450

- Using the Hexagon Wrench, turn the adjusting collar [C] counterclockwise to make the gap between the engine and adjusting collar.

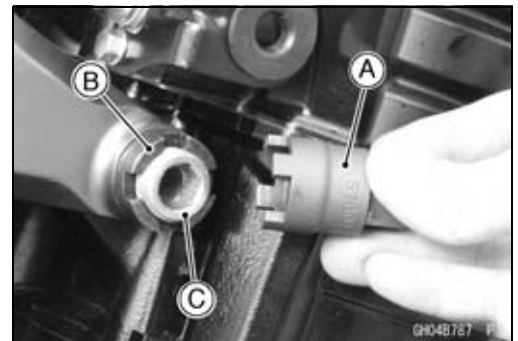

- Using the nut wrench [A], loosen the lower adjusting collar locknut [B].

Special Tool - Engine Mount Nut Wrench: 57001-1450

- Remove the lower engine mounting bolt [C].
- Using the Hexagon Wrench, turn the adjusting collar [D] counterclockwise to make the gap between the engine and adjusting collar.
- Using the stand, take out the engine.

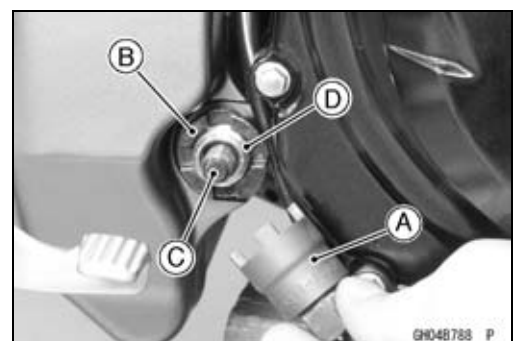

8-8 ENGINE REMOVAL/INSTALLATION

Engine Removal/Installation

Engine Installation

- Support the engine with a suitable stand.
- Put a plank onto the suitable stand for engine balance.
- Screw the adjusting collars [A] to the frame.

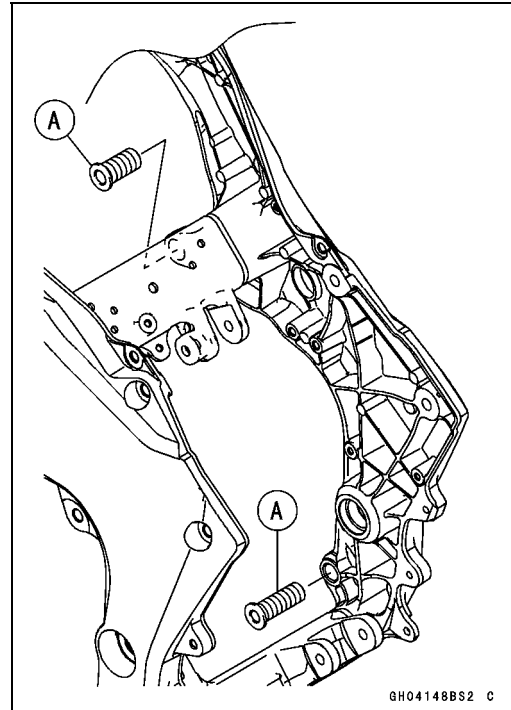

- Install the engine mounting bolts and nuts, following the specified installing sequence.
- First, hang the drive chain over the output shaft just before moving the engine into its final position in the frame.
- Second, apply a non-permanent locking agent to the threads of the middle engine bracket bolts [A]. Install the middle engine bracket [B] and tighten the bolts.

Torque - Middle Engine Bracket Bolts: 25 N·m (2.5 kgf·m, 18 ft·lb)

- Third, insert the lower engine mounting bolt [C].
- Fourth, install the collar [D], and insert the middle engine mounting bolt [E].
- Fifth, tighten:

Torque - Left Upper Engine Mounting Bolt [F]: 44 N·m (4.5 kgf·m, 32 ft·lb)

- Sixth, tighten the upper adjusting collar locknut [G] and right upper engine mounting bolt [H] temporarily.
- Seventh, tighten the lower adjusting collar [I] until the clearance between the engine and frame comes to 0 mm.
- Eighth, tighten the lower adjusting collar locknut [J] and lower engine mounting nut [K].

Torque - Lower Adjusting Collar Locknut: 49 N·m (5.0 kgf·m, 36 ft·lb)

Lower Engine Mounting Nut: 44 N·m (4.5 kgf·m, 32 ft·lb)

Special Tool - Engine Mount Nut Wrench: 57001-1450

- Ninth, tighten:

Torque - Middle Engine Mounting Nut [L]: 44 N·m (4.5 kgf·m, 32 ft·lb)

- Tenth, install the left engine bracket [M], and tighten the mounting bolts evenly.

Torque - Upper Engine Bracket Bolts [N]: 44 N·m (4.5 kgf·m, 32 ft·lb)

Lower Engine Bracket Bolts [O]: 59 N·m (6.0 kgf·m, 36 ft·lb)

- Eleventh, install the right engine bracket [P] just like the left engine bracket.
- Twelfth, remove the right upper engine mounting bolt [H].
- Thirteenth, tighten the upper adjusting collar [Q] until the clearance between the engine and frame comes to 0 mm.
- Fourteenth, tighten the upper adjusting collar locknut [G].

Torque - Upper Adjusting Collar Locknut: 49 N·m (5.0 kgf·m, 36 ft·lb)

Special Tool - Engine Mount Nut Wrench: 57001-1450

- Lastly, tighten:

Torque - Right Upper Engine Mounting Bolt [H]: 44 N·m (4.5 kgf·m, 32 ft·lb)

Engine Removal/Installation

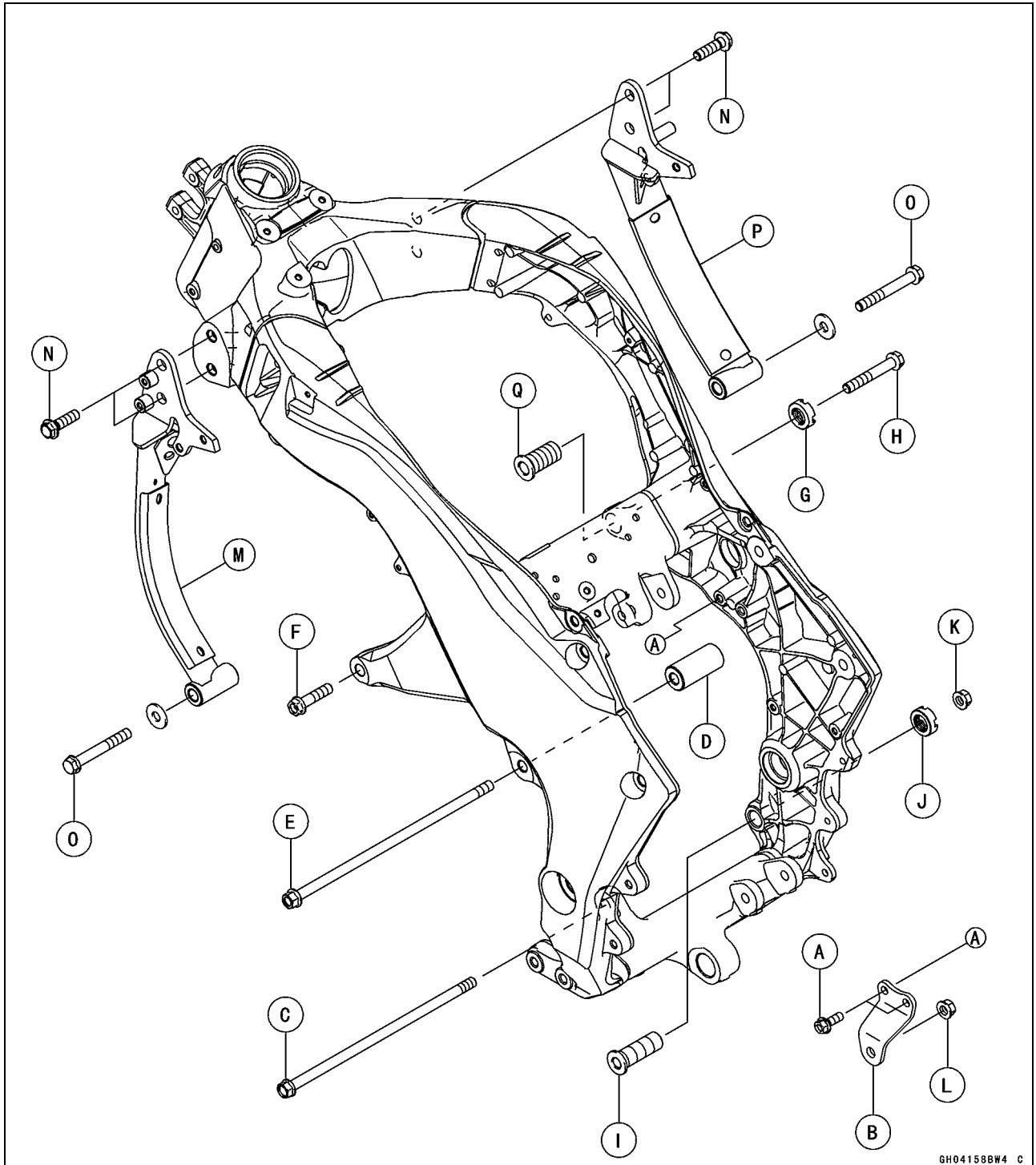

GH04158BW4 C

- Run the leads, cables and hoses correctly (see Cable, Wire, and Hose Routing section in the Appendix chapter).
- Install the removed parts (see appropriate chapters).

Torque - Engine Ground Cable Terminal Bolt: 9.8 N·m (1.0 kgf·m, 87 in·lb)

- Adjust:
 - Throttle Cables (see Throttle Control System Inspection in the Periodic Maintenance chapter)
 - Clutch Cable (see Clutch Operation Inspection in the Periodic Maintenance chapter)
 - Drive Chain (see Drive Chain Slack Inspection in the Periodic Maintenance chapter)

8-10 ENGINE REMOVAL/INSTALLATION

Engine Removal/Installation

- Fill the engine with engine oil (see Engine Oil Change in the Periodic Maintenance chapter).
- Fill the engine with coolant (see Coolant Change in the Periodic Maintenance chapter).

Crankshaft/Transmission

Table of Contents

Exploded View.....	9-2	Starter Motor Clutch Disassembly	9-27
Specifications	9-6	Starter Motor Clutch Assembly	9-27
Special Tools and Sealants	9-8	External Shift Mechanism.....	9-28
Crankcase Splitting.....	9-9	Shift Pedal Removal	9-28
Crankcase Splitting	9-9	Shift Pedal Installation	9-28
Crankcase Assembly	9-10	External Shift Mechanism	
Crankshaft and Connecting Rods.....	9-16	Removal.....	9-28
Crankshaft Removal	9-16	External Shift Mechanism	
Crankshaft Installation	9-16	Installation.....	9-29
Connecting Rod Removal.....	9-16	External Shift Mechanism	
Connecting Rod Installation.....	9-16	Inspection.....	9-30
Crankshaft/Connecting Rod		Transmission	9-32
Cleaning.....	9-20	Transmission Shaft Removal	9-32
Connecting Rod Bend Inspection	9-20	Transmission Shaft Installation	9-32
Connecting Rod Twist Inspection.	9-20	Transmission Shaft Disassembly .	9-32
Connecting Rod Big End Side		Transmission Shaft Assembly.....	9-33
Clearance Inspection	9-20	Shift Drum and Fork Removal.....	9-38
Connecting Rod Big End		Shift Drum and Fork Installation...	9-38
Bearing Insert/Crankpin Wear		Shift Drum Disassembly.....	9-38
Inspection.....	9-21	Shift Drum Assembly	9-38
Crankshaft Side Clearance		Shift Fork Bending Inspection	9-38
Inspection.....	9-22	Shift Fork/Gear Groove Wear	
Crankshaft Runout Inspection.....	9-23	Inspection.....	9-39
Crankshaft Main Bearing		Shift Fork Guide Pin/Drum	
Insert/Journal Wear Inspection .	9-23	Groove Wear Inspection	9-39
Balancer	9-25	Gear Dog and Gear Dog Hole	
Balancer Removal.....	9-25	Damage Inspection	9-39
Balancer Installation.....	9-25	Ball Bearing, Needle Bearing, and Oil	
Balancer Adjustment.....	9-26	Seal.....	9-40
Balancer Damper Inspection.....	9-26	Ball and Needle Bearing	
Starter Motor Clutch	9-27	Replacement.....	9-40
Starter Motor Clutch		Ball and Needle Bearing Wear.....	9-40
Removal/Installation.....	9-27	Oil Seal Inspection.....	9-40
Starter Motor Clutch Inspection ...	9-27		

9-2 CRANKSHAFT/TRANSMISSION

Exploded View

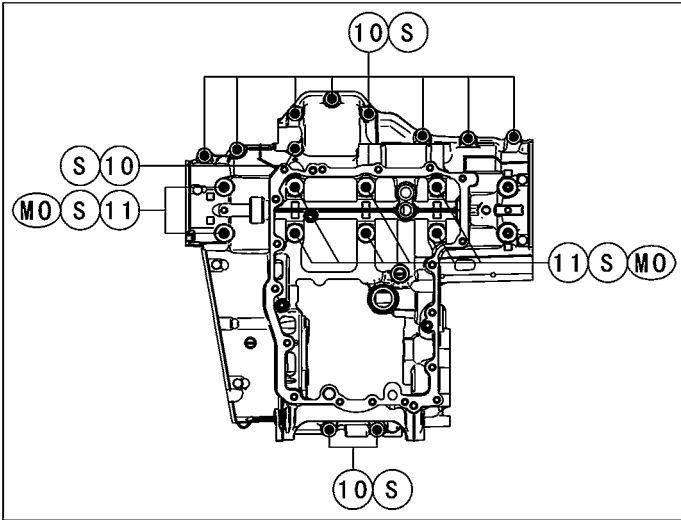
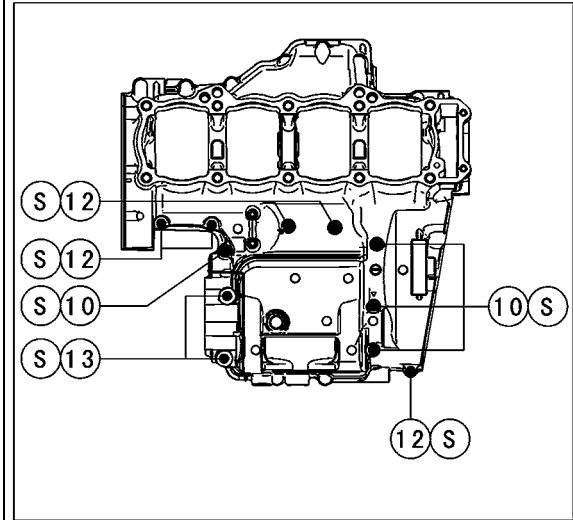
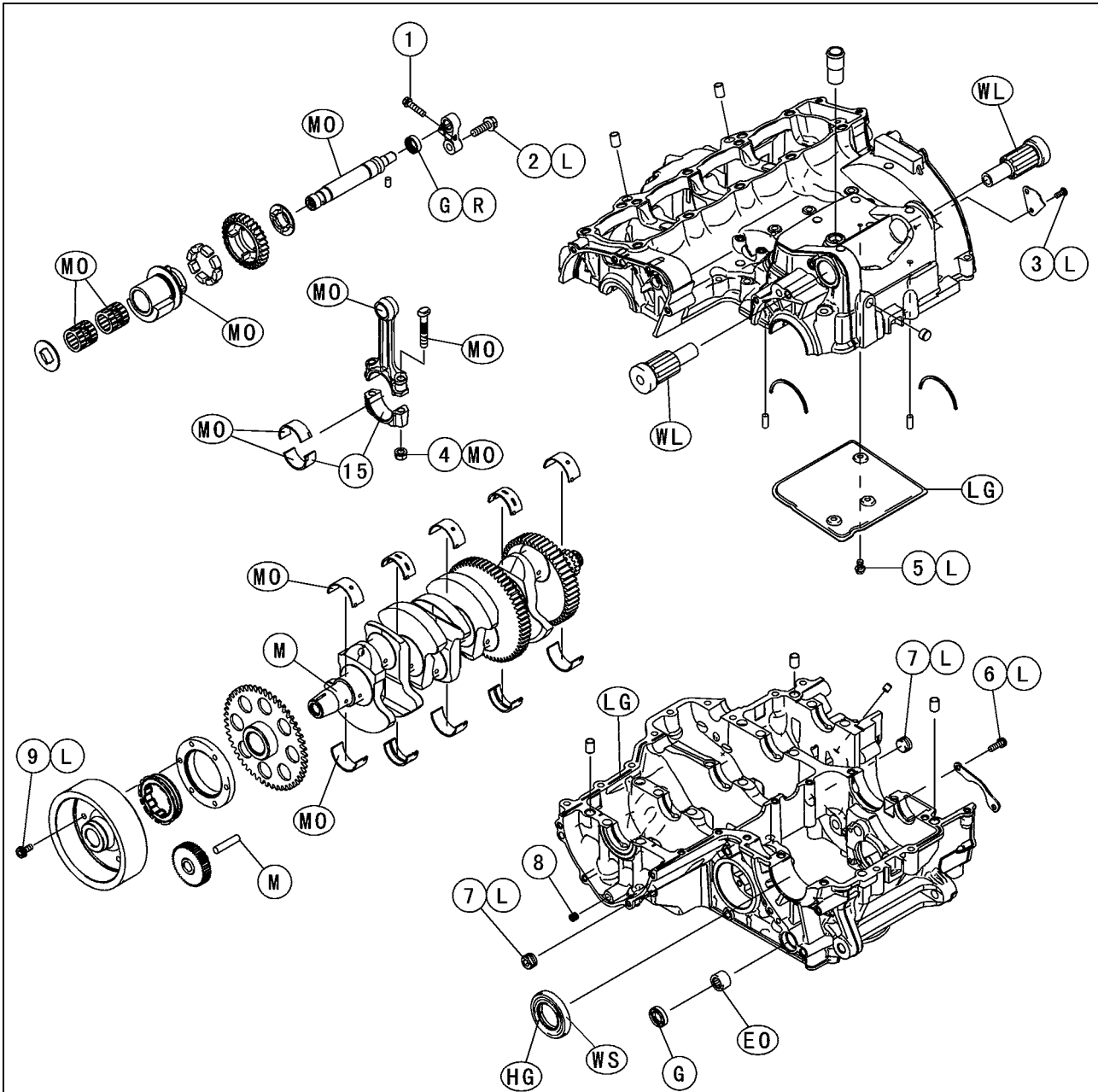

Exploded View

No.	Fastener	Torque			Remarks
		N·m	kgf·m	ft·lb	
1	Balancer Shaft Clamp Bolt	9.8	1.0	87 in·lb	
2	Balancer Shaft Lever Bolt	25	2.5	18	L
3	Breather Side Plate Bolt	5.9	0.60	52 in·lb	L
4	Connecting Rod Big End Nuts	see the text	←	←	MO
5	Breather Plate Bolts	9.8	1.0	87 in·lb	L
6	Shift Drum Bearing Holder Bolts	12	1.2	106 in·lb	L
7	Oil Passage Plugs	20	2.0	15	L
8	Oil Passage Plug	9.8	1.0	87 in·lb	
9	Starter Motor Clutch Bolts	12	1.2	106 in·lb	L
10	Crankcase Bolts (M7)	20	2.0	15	S
11	Crankcase Bolts (M9)	42	4.2	31	S, MO
12	Crankcase Bolts (M6)	20	2.0	15	S
13	Crankcase Bolts (M8)	27	2.8	20	S

15. Do not apply any grease or oil.

EO: Apply engine oil.

G: Apply grease.

HG: Apply high-temperature grease.

L: Apply a non-permanent locking agent.

LG: Apply liquid gasket.

M: Apply molybdenum disulfide grease.

MO: Apply molybdenum disulfide oil solution.

(mixture of the engine oil and molybdenum disulfide grease in a weight ratio 10:1)

R: Replacement Parts

S: Follow the specified tightening sequence.

WL: Apply soap and water solution or rubber lubricant.

WS: Apply water-soluble lubricant (ThreeBond:TB2720C).

9-4 CRANKSHAFT/TRANSMISSION

Exploded View

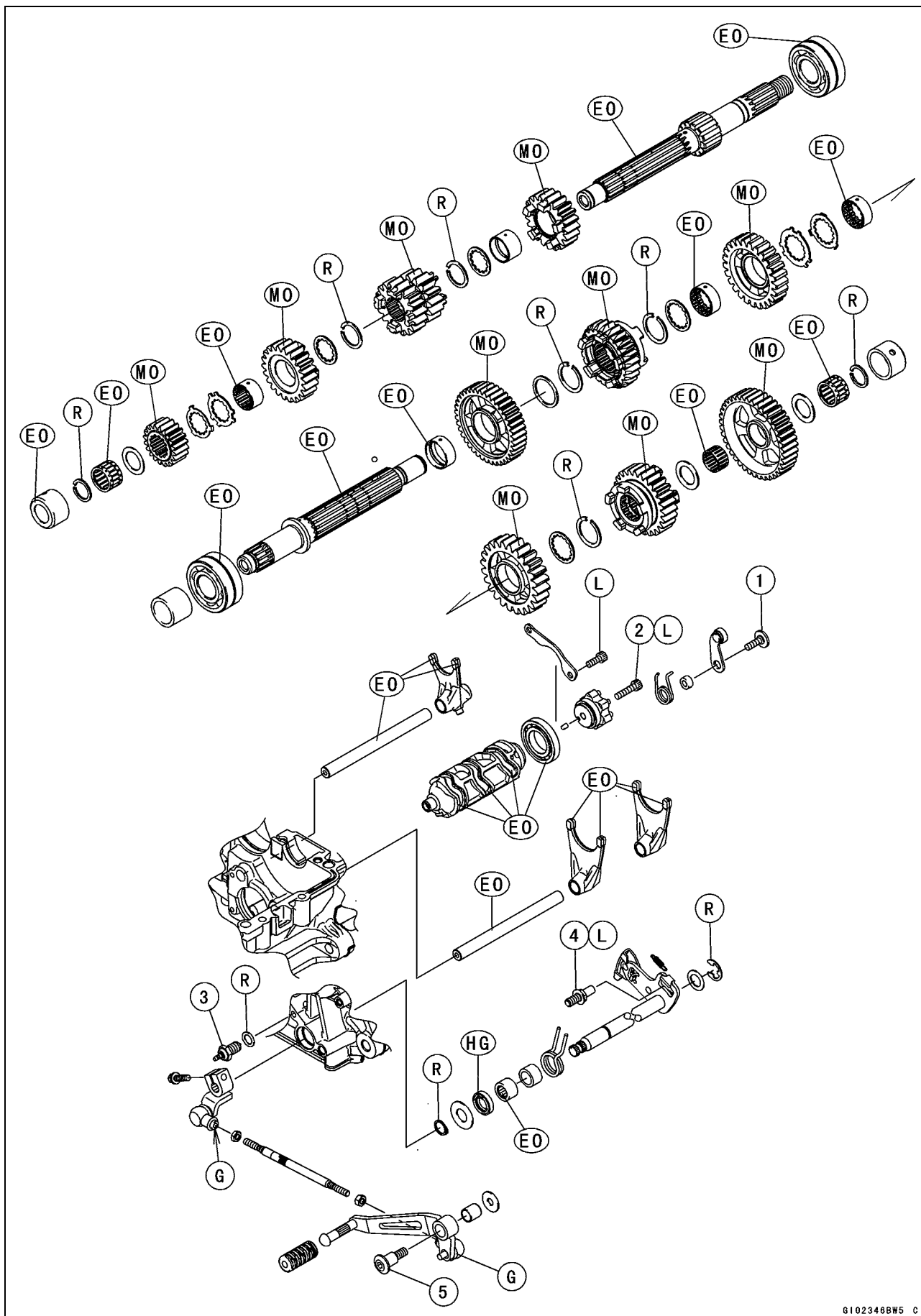

CRANKSHAFT/TRANSMISSION 9-5

Exploded View

No.	Fastener	Torque			Remarks
		N·m	kgf·m	ft·lb	
1	Gear Positioning Lever Bolt	12	1.2	106 in·lb	
2	Shift Drum Cam Bolt	12	1.2	106 in·lb	L
3	Neutral Switch	15	1.5	11	
4	Shift Shaft Return Spring Pin	39	4.0	29	L
5	Shift Pedal Mounting Bolt	25	2.5	18	

EO: Apply engine oil.

G: Apply grease.

HG: Apply high-temperature grease.

MO: Apply molybdenum disulfide oil.

(mixture of the engine oil and molybdenum disulfide grease in a weight ratio 10:1)

L: Apply a non-permanent locking agent.

R: Replacement Parts

9-6 CRANKSHAFT/TRANSMISSION

Specifications

Item	Standard	Service Limit
Crankcase, Crankshaft, Connecting Rods		
Connecting Rod Bend	— — —	TIR 0.2/100 mm (0.008/3.94 in.)
Connecting Rod Twist	— — —	TIR 0.2/100 mm (0.008/3.94 in.)
Connecting Rod Big End Side Clearance	0.13 ~ 0.38 mm (0.0051 ~ 0.0150 in.)	0.58 mm (0.023 in.)
Connecting Rod Big End Bearing Insert/Crankpin Clearance	0.030 ~ 0.060 mm (0.0012 ~ 0.0024 in.)	0.10 mm (0.0039 in.)
Crankpin Diameter:	34.484 ~ 34.500 mm (1.3576 ~ 1.3583 in.)	34.47 mm (1.357 in.)
Marking:		
None	34.484 ~ 34.492 mm (1.3576 ~ 1.3579 in.)	— — —
○	34.493 ~ 34.500 mm (1.3580 ~ 1.3583 in.)	— — —
Connecting Rod Big End Inside Diameter:	37.500 ~ 37.516 mm (1.4764 ~ 1.4770 in.)	— — —
Marking:		
None	37.500 ~ 37.508 mm (1.4764 ~ 1.4766 in.)	— — —
○	37.509 ~ 37.516 mm (1.4767 ~ 1.4770 in.)	— — —
Connecting Rod Big End Bearing Insert Thickness:		
Brown	1.478 ~ 1.483 mm (0.05819 ~ 0.05839 in.)	— — —
Black	1.483 ~ 1.488 mm (0.05839 ~ 0.05858 in.)	— — —
Blue	1.488 ~ 1.493 mm (0.05858 ~ 0.05878 in.)	— — —
Connecting Rod Bolt Stretch	(Usable Range) 0.20 ~ 0.32 mm (0.0079 ~ 0.0126 in.)	— — —
Crankshaft Side Clearance	0.09 ~ 0.19 mm (0.0035 ~ 0.0075 in.)	0.39 mm (0.0153 in.)
Crankshaft #3 Main Journal Width	23.49 ~ 23.54 mm (0.9248 ~ 0.9267 in.)	— — —
Crankshaft Runout	TIR 0.02 mm (0.0008 in.) or less	TIR 0.05 mm (0.0020 in.)
Crankshaft Main Bearing Insert/Journal Clearance	0.010 ~ 0.034 mm (0.0004 ~ 0.0013 in.)	0.06 mm (0.0024 in.)
Crankshaft Main Journal Diameter:	34.984 ~ 35.000 mm (1.3773 ~ 1.3780 in.)	34.96 mm (1.3764 in.)
Marking:		
None	34.984 ~ 34.992 mm (1.3773 ~ 1.3776 in.)	— — —
1	34.993 ~ 35.000 mm (1.3777 ~ 1.3780 in.)	— — —
Crankcase Main Bearing Inside Diameter:	38.000 ~ 38.016 mm (1.4961 ~ 1.4967 in.)	— — —
Marking:		
None	38.009 ~ 38.016 mm (1.4964 ~ 1.4967 in.)	— — —
○	38.000 ~ 38.008 mm (1.4961 ~ 1.4963 in.)	— — —

CRANKSHAFT/TRANSMISSION 9-7

Specifications

Item	Standard	Service Limit
Crankshaft Main Bearing Insert Thickness:		
Brown	1.491 ~ 1.495 mm (0.0587 ~ 0.0589 in.)	— — —
Black	1.495 ~ 1.499 mm (0.0589 ~ 0.0590 in.)	— — —
Blue	1.499 ~ 1.503 mm (0.0590 ~ 0.0592 in.)	— — —
Transmission		
Shift Fork Ear Thickness	5.9 ~ 6.0 mm (0.232 ~ 0.236 in.)	5.8 mm (0.228 in.)
Gear Groove Width	6.05 ~ 6.15 mm (0.238 ~ 0.242 in.)	6.25 mm (0.246 in.)
Shift Fork Guide Pin Diameter	6.9 ~ 7.0 mm (0.272 ~ 0.276 in.)	6.8 mm (0.268 in.)
Shift Drum Groove Width	7.05 ~ 7.20 mm (0.278 ~ 0.283 in.)	7.3 mm (0.287 in.)

Connecting Rod Big End Bearing Insert Selection

Con-rod Big End Inside Diameter Marking	Crankpin Diameter Marking	Bearing Insert	
		Size Color	Part Number
None	○	Brown	92139-0124
None	None	Black	92139-0123
○	○		
○	None	Blue	92139-0122

Crankshaft Main Bearing Insert Selection

Crankcase Main Bearing Inside Diameter Marking	Crankshaft Main Journal Diameter Marking	Bearing Insert*		
		Size Color	Part Number	Journal Nos.
○	1	Brown	92139-0034	2, 4
			92139-0219	1, 3, 5
None	1	Black	92139-0033	2, 4
○	None		92139-0218	1, 3, 5
None	None	Blue	92139-0032	2, 4
			92139-0217	1, 3, 5

*: The bearing inserts for Nos. 2 and 4 journals have an oil groove, respectively.

9-8 CRANKSHAFT/TRANSMISSION

Special Tools and Sealants

Bearing Puller:
57001-135

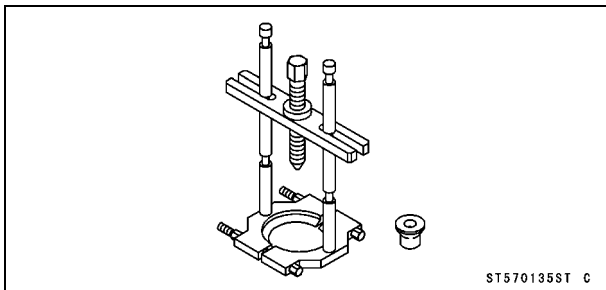

Bearing Driver Set:
57001-1129

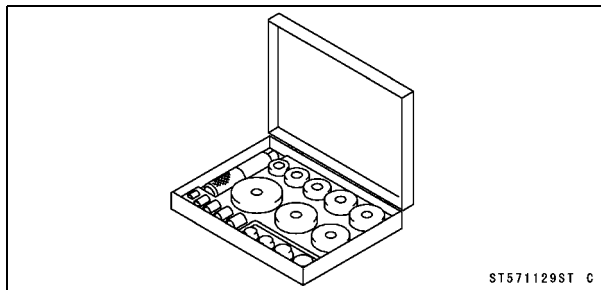

Outside Circlip Pliers:
57001-144

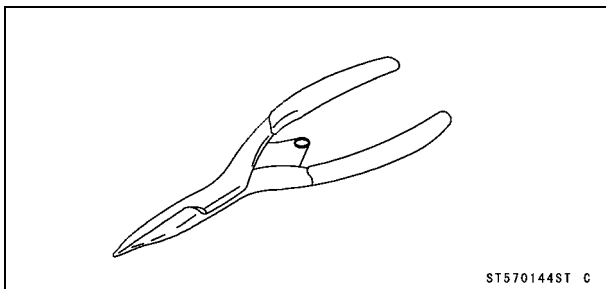

Flywheel Holder:
57001-1313

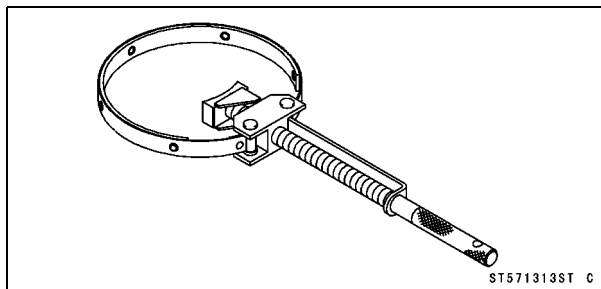

Bearing Puller Adapter:
57001-317

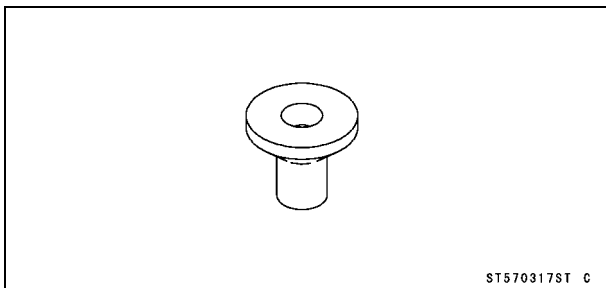

Liquid Gasket, TB1216B:
92104-1064

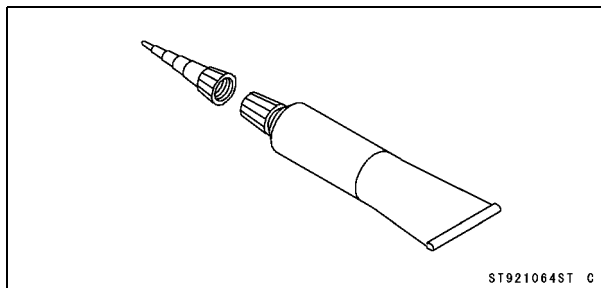

Bearing Driver, $\phi 32$:
57001-382

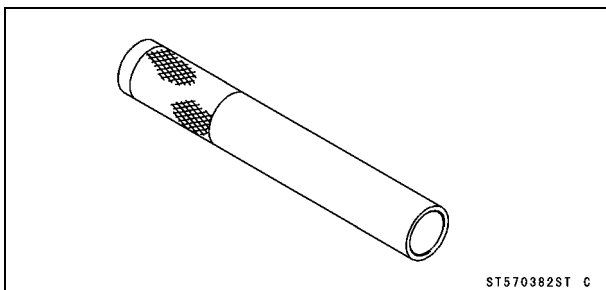

Liquid Gasket, TB1207B:
92104-2068

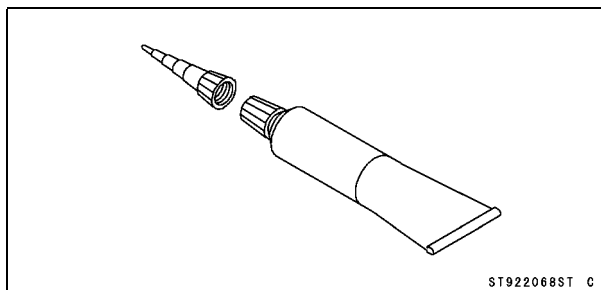

Crankcase Splitting

Crankcase Splitting

- Remove the engine (see Engine Removal in the Engine Removal/Installation chapter).
- Set the engine on a clean surface and hold the engine steady while parts are being removed.
- Remove:
 - Cylinder (see Cylinder Removal in the Engine Top End chapter)
 - Clutch (see Clutch Removal in the Clutch chapter)
 - External Shift Mechanism (see External Shift Mechanism Removal)
 - Starter Motor (see Starter Motor Removal in the Electrical System chapter)
 - Oil Pump (see Oil Pump Removal in the Engine Lubrication System chapter)
 - Alternator Rotor (see Alternator Rotor Removal in the Electrical System chapter)
 - Oil Filter (see Oil Filter Replacement in the Periodic Maintenance chapter)
 - Oil Cooler (see Oil Cooler Removal in the Engine Lubrication System chapter)
 - Oil Pipe (see Oil Pipe Removal in the Engine Lubrication System chapter)
 - Oil Pressure Relief Valve (see Oil Pressure Relief Valve Removal in the Engine Lubrication System chapter)
- ★ If the crankshaft is to be removed, remove the pistons (see Piston Removal in the Engine Top End chapter).
- Remove:
 - Balancer Shaft Clamp Bolt [A]
 - Balancer Shaft Clamp Lever Bolt [B]

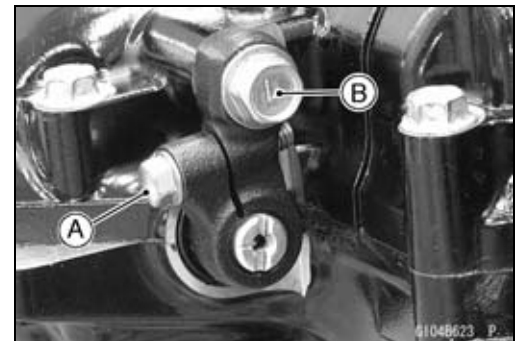

- Remove the upper crankcase bolts following the specified sequence.
 - First, loosen the M6 bolts [A].
 - Second, loosen the M7 bolts [B].
 - Lasty, loosen the M8 bolts [C].

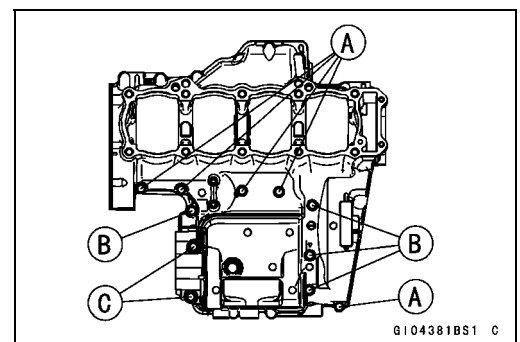

9-10 CRANKSHAFT/TRANSMISSION

Crankcase Splitting

- Remove the lower crankcase bolts, following the specified sequence.
- First, loosen the M7 bolts [A].
- Lastly, loosen the M9 bolts as shown sequence [1 ~ 10] in the figure.
- Tap lightly around the crankcase mating surface with a plastic mallet, and split the crankcase.
- Take care not to damage the crankcase.

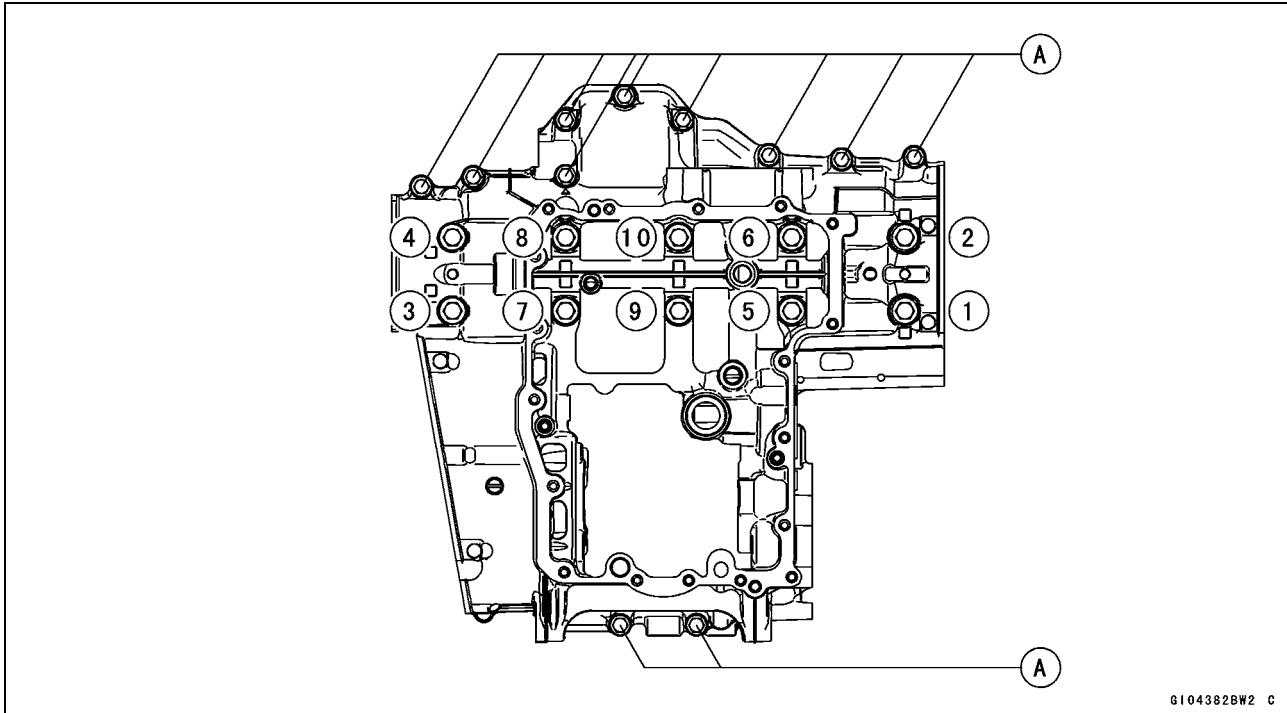

Crankcase Assembly

NOTICE

The upper and lower crankcase halves are machined at the factory in the assembled state, so the crankcase halves must be replaced as a set.

- With a high-flash point solvent, clean off the mating surfaces of the crankcase halves and wipe dry.
- Using compressed air, blow out the oil passages in the crankcase halves.
- Apply liquid gasket to the breather plate mating surface [A] 1 mm (0.04 in.) or more thick, and then install the breather plate.
- Using a high-flash point solvent, clean off any oil or dirt that may be on the liquid gasket coating area. Dry them with a clean cloth.

Sealant - Liquid Gasket, TB1207B: 92104-2068

NOTE

- Make the application finish within 7 minutes when the liquid gasket to the mating surface of the breather plate is applied.
- Moreover fit the plate and tighten the bolts just after application of the liquid gasket.

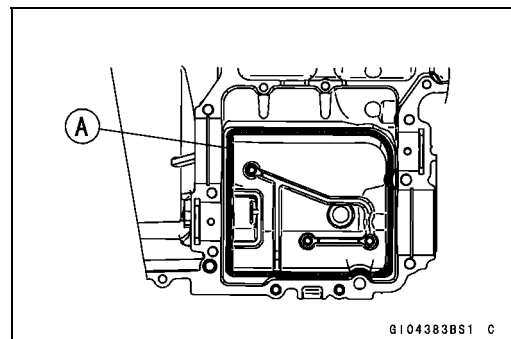

Crankcase Splitting

- Apply a non-permanent locking agent to the threads of the breather plate bolts [A] and tighten them.

Torque - Breather Plate Bolts: 9.8 N·m (1.0 kgf·m, 87 in·lb)

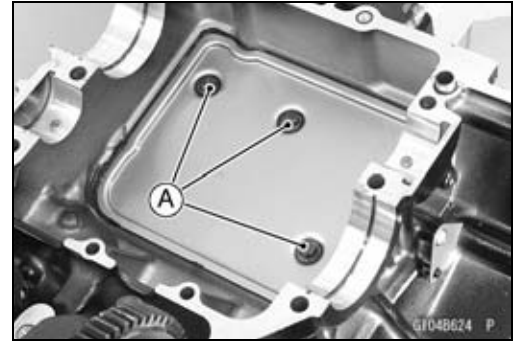

- Install the breather side plate [A] so that the plate hole [B] fit the projection [C] of the upper crankcase.
- Apply a non-permanent locking agent to the threads of the breather side plate bolt [D] and tighten it.

Torque - Breather Side Plate Bolt: 5.9 N·m (0.60 kgf·m, 52 in·lb)

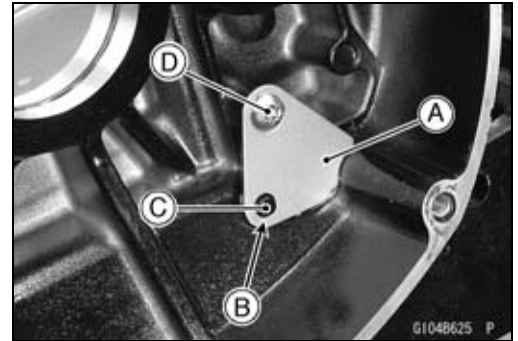

- Press and insert the fitting [A] in the upper crankcase [B] until it is bottomed.

Special Tool - Bearing Driver Set: 57001-1129

- Press and insert the plug [C] in the upper crankcase so that the plug is deeper than crankcase surface.

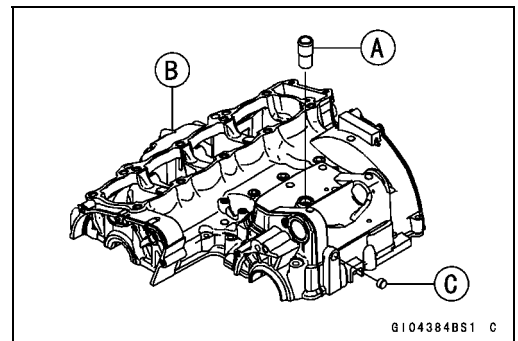

- Press and insert the new needle bearing [A] for the shift shaft so that its marked side faces outside and its surface [B] is flush with the end of the hole.
- Install the new oil seal [C] so that its surface [D] is flush with the end of the hole.
- Apply grease to the oil seal lips.

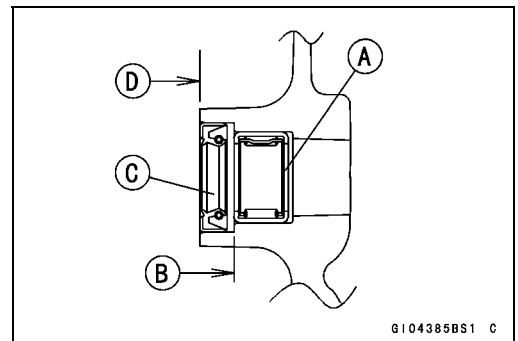

9-12 CRANKSHAFT/TRANSMISSION

Crankcase Splitting

- Apply a non-permanent locking agent to the oil passage plugs [A], and tighten them.

Torque - Oil Passage Plugs: 20 N·m (2.0 kgf·m, 15 ft·lb)

- Install the oil passage plug [B] in the lower crankcase, and tighten it.

Torque - Oil Passage Plug: 9.8 N·m (1.0 kgf·m, 87 in·lb)

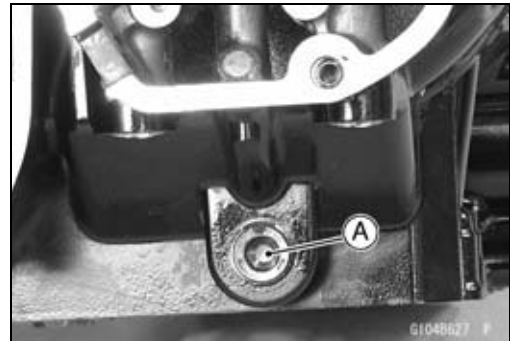
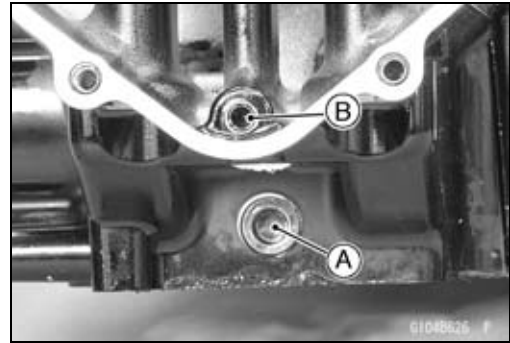

- Install:
 - Crankshaft (see Crankshaft Installation)
 - Connecting Rods (see Connecting Rod Installation)
 - Camshaft Chain [A]
 - Transmission Shafts and Gears (see Transmission Shaft Installation)
 - Dowel Pins [B]
 - Shift Drum (see Shift Drum and Fork Installation)
 - Shift Forks and Shift Rods (see Shift Drum and Fork Installation)
- Before fitting the lower case on the upper case, check the following.
 - Be sure to hang the camshaft chain on the crankshaft.
 - Check to see that the shift drum and transmission gears are in the neutral position.

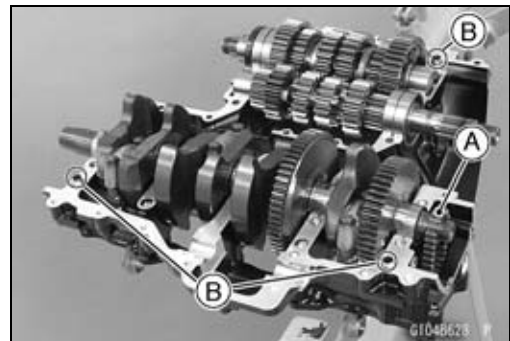

Crankcase Splitting

- Apply liquid gasket [A] to the mating surface of the lower crankcase half.
- Using a high-flash point solvent, clean off any oil or dirt that may be on the liquid gasket coating area. Dry them with a clean cloth.

Sealant - Liquid Gasket, TB1216B: 92104-1064

NOTE

- Especially, apply a sealant so that it shall be filled up on the grooves [B].
- Do not apply liquid gasket to the inside of the groove [C].

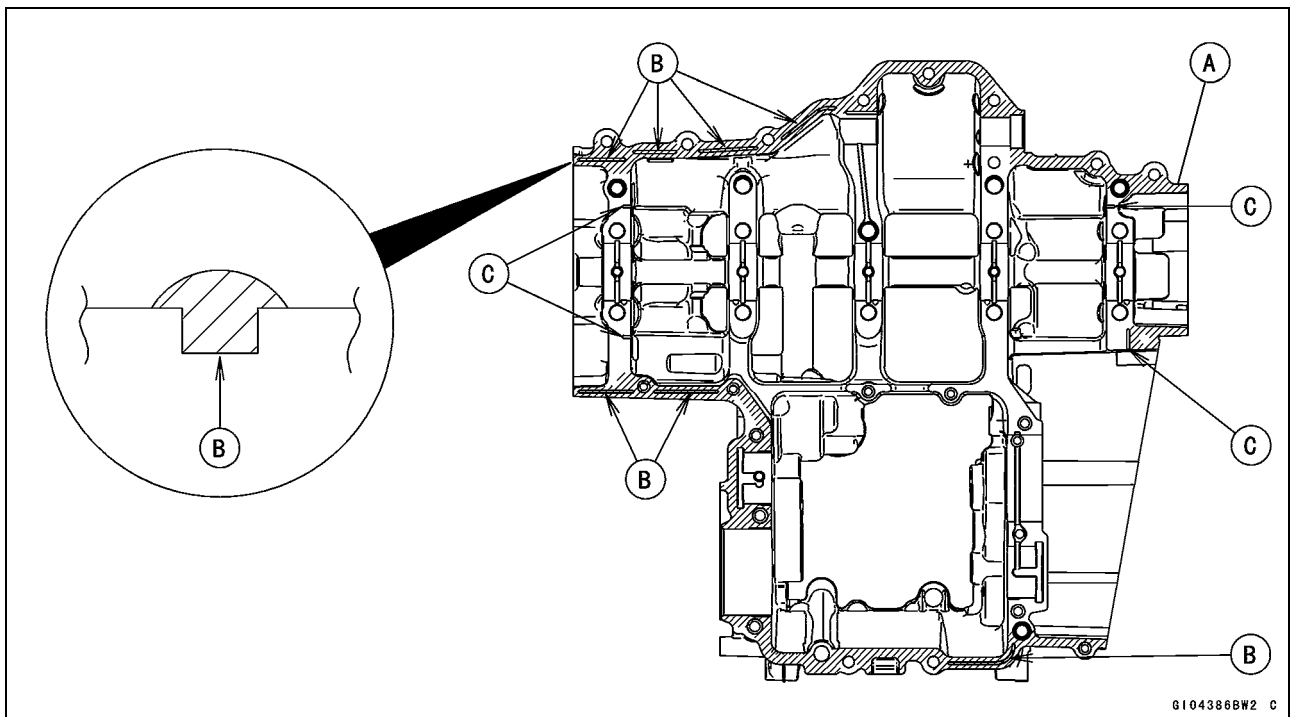

G104386W2 C

NOTICE

Do not apply liquid gasket around the crankshaft main bearing inserts and oil passage holes.

- Fit the lower crankcase to the upper crankcase.

NOTE

- Make the application finish within 20 minutes when the liquid gasket to the mating surface of the crankcase half is applied.
 - Moreover fit the case and tighten the bolts just after application of the liquid gasket.
- The M9 bolts have copper plated washers, replace them with new ones.

9-14 CRANKSHAFT/TRANSMISSION

Crankcase Splitting

- Apply molybdenum disulfide oil solution to the lower seating surface [A] on the copper plated washer [B] and threads [C] of the M9 bolts [D].

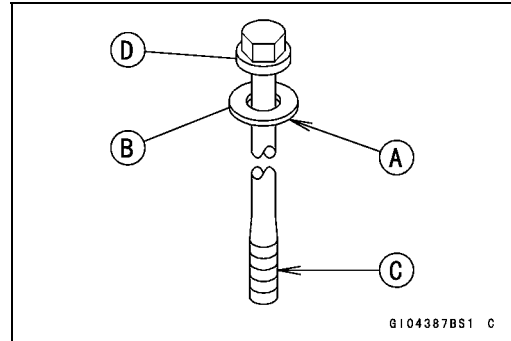

- Tighten the lower crankcase bolts using the following steps.
 - Following the sequence numbers on the lower crankcase half, tighten the M9 bolts [1 ~ 10] with copper plated washers.
 - Torque - Crankcase Bolts (M9): 42 N·m (4.2 kgf·m, 31 ft·lb)**
 - Tighten the M7 bolts [A].
 - Torque - Crankcase Bolts (M7): 20 N·m (2.0 kgf·m, 15 ft·lb)**

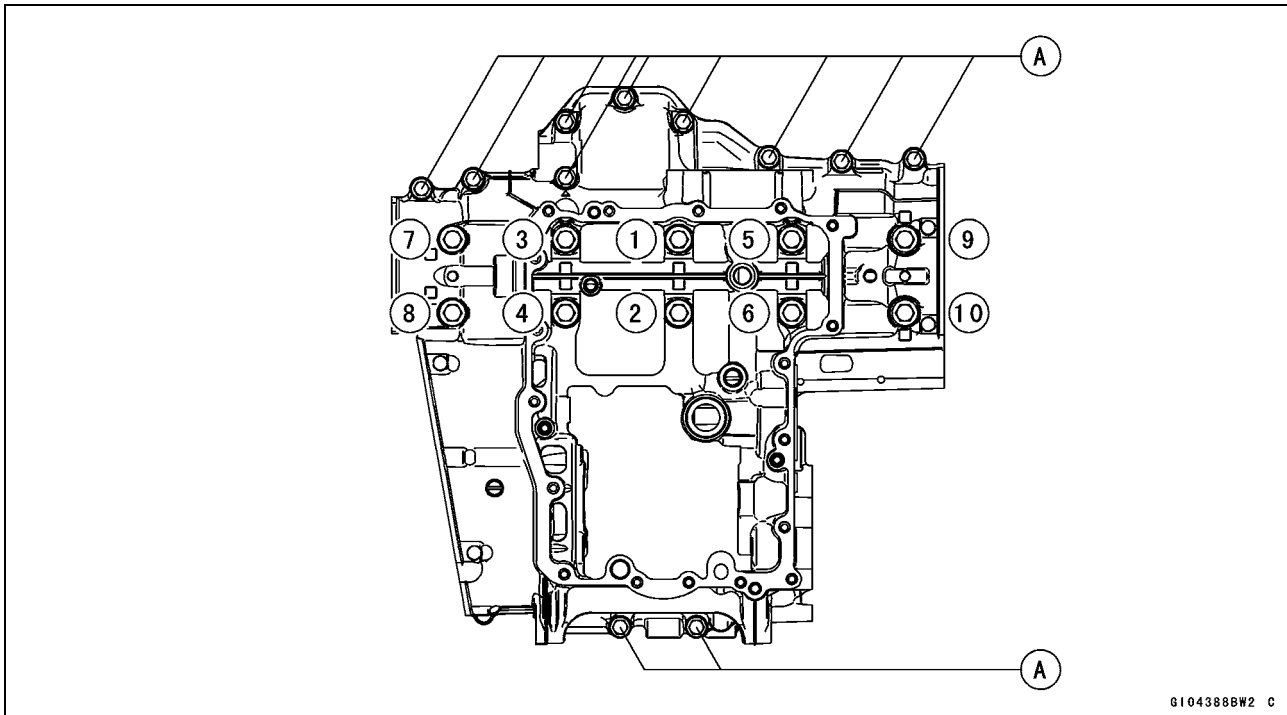

- Tighten the upper crankcase bolts follow in the specified sequence.
 - First, tighten the M8 bolts [A].
 - Torque - Crank Case Bolts (M8): 27 N·m (2.8 kgf·m, 20 ft·lb)**
 - Second, tighten the M7 bolts.
 - L = 85 mm (3.35 in.) [B]
 - L = 50 mm (1.97 in.) [C]
 - Torque - Crank Case Bolts (M7): 20 N·m (2.0 kgf·m, 15 ft·lb)**
 - Lasty, tighten the M6 bolts.
 - L = 68 mm (2.69 in.) [D]
 - L = 40 mm (1.57 in.) [E]
 - Torque - Crank Case Bolts (M6): 12 N·m (1.2 kgf·m, 106 in·lb)**

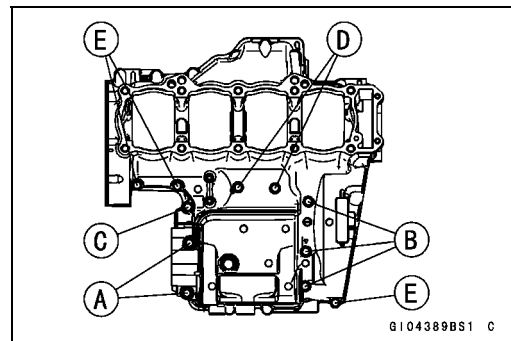

Crankcase Splitting

- After tightening all crankcase bolts, check the following items.
- Wipe up the liquid gasket that seeps out around the crankcase mating surface.
- Crankshaft and transmission shafts turn freely.
- While spinning the output shaft, gears shift smoothly from the 1st to 6th gear, and 6th to 1st.
- When the output shaft stays still, the gear can not be shifted to 2nd gear or other higher gear positions.
- Install the removed parts (see appropriate chapters).

9-16 CRANKSHAFT/TRANSMISSION

Crankshaft and Connecting Rods

Crankshaft Removal

- Split the crankcase (see Crankcase Splitting).
- Remove:
 - Balancer (see Balancer Removal)
 - Crankshaft [A]

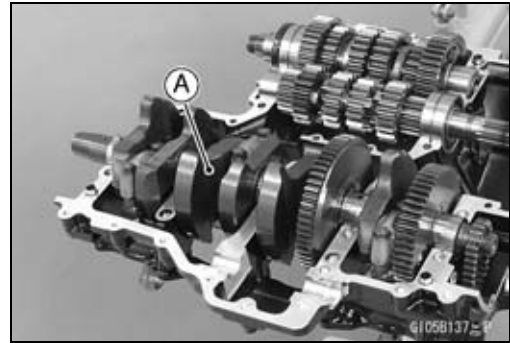

Crankshaft Installation

NOTICE

If the crankshaft, bearing inserts, or crankcase halves are replaced with new ones, select the bearing inserts and check clearance with a plastigage (press gauge) before assembling engine to be sure the correct bearing inserts are installed.

- Apply molybdenum disulfide oil solution to the crankshaft main bearing inserts.
- Install the crankshaft with the camshaft chain [A] hanging on it.
- Install the balancer (see Balancer Installation).

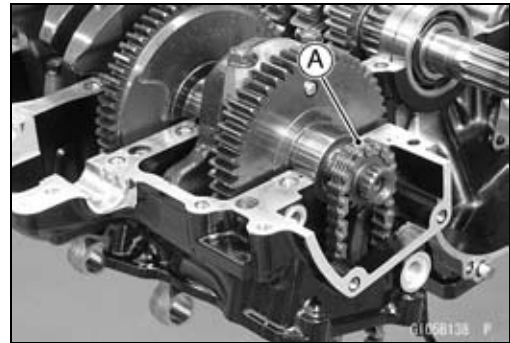

Connecting Rod Removal

- Split the crankcase (see Crankcase Splitting).
- Remove the connecting rod big end nuts [A].
- Remove the crankshaft.

NOTE

○ Mark and record the locations of the connecting rods and their big end caps so that they can be reassembled in their original positions.

- Remove the connecting rods from the crankshaft.

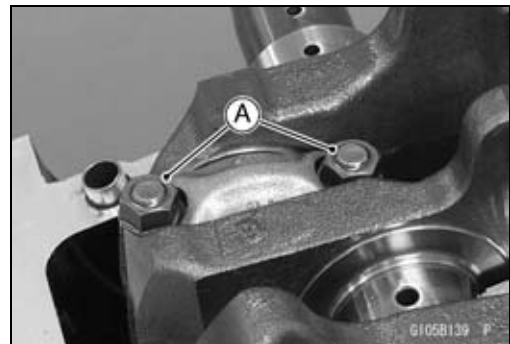

NOTICE

Discard the connecting rod bolts. To prevent damage to the crankpin surfaces, do not allow the connecting rod bolts to bump against the crankpins.

Connecting Rod Installation

NOTICE

To minimize vibration, the connecting rods should have the same weight mark.

- Big End Cap [A]
- Connecting Rod [B]
- Weight Mark, Alphabet [C]
- Diameter Mark [D]: "O" or no mark

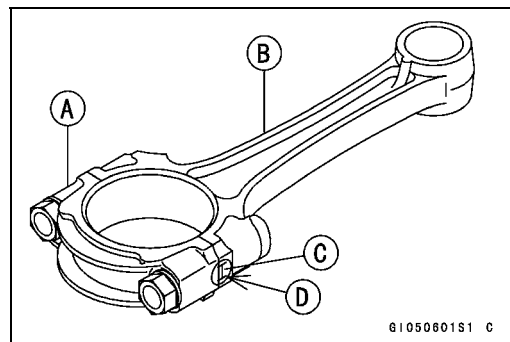

NOTICE

If the connecting rods, big end bearing inserts, or crankshaft are replaced with new ones, select the bearing insert and check clearance with a plastigage (press gauge) before assembling engine to be sure the correct bearing inserts are installed.

Crankshaft and Connecting Rods

- Apply molybdenum disulfide oil solution [A] to the inner surfaces of upper and lower bearing inserts.
- Do not apply any grease or oil to the cap inside and cap insert outside [B].
- Install the inserts so that their nails [C] are on the same side and fit them into the recess of the connecting rod and cap.

NOTICE

Wrong application of oil and grease could cause bearing damage.

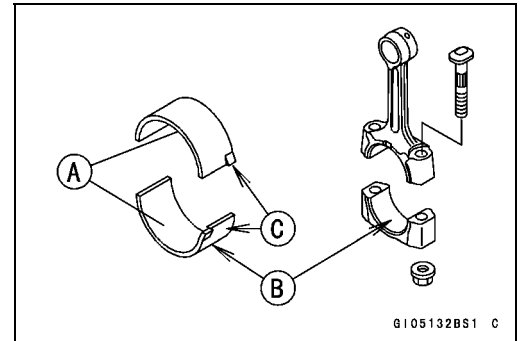

- When installing the inserts [A], be careful not to damage the insert surface with the edge of the connecting rod [B] or the cap [C]. One way to install inserts is as follows.

- Installation [D] to Cap
- Installation [E] to Connecting Rod
- Push [F]
- Spare Dowel Pin [G]
- Connecting Rod Bolts [H]

- Install the cap on the connecting rod, aligning the weight and diameter marks.
- Remove debris and clean the surface of inserts.
- Apply molybdenum disulfide oil solution [MO] to the threads and seating surfaces of the big end nuts and bolts.

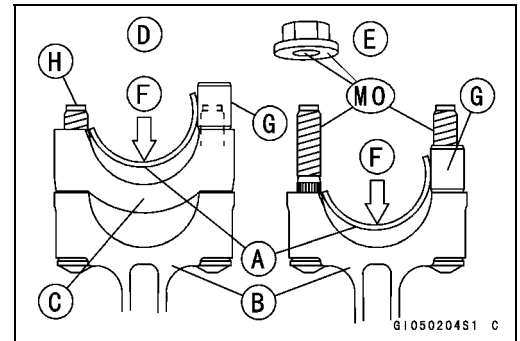

- Install the crankshaft (see Crankshaft Installation).
- Install each connecting rod on its original crankpin.
- The connecting rod big end is bolted using the “plastic region fastening method”.
- This method precisely achieves the needed clamping force without exceeding it unnecessarily, allowing the use of thinner, lighter bolts further decreasing connecting rod weight.
- There are two types of the plastic region fastening. One is a bolt length measurement method and other is a rotation angle method. Observe one of the following two, but the bolt length measurement method is preferable because this is a more reliable way to tighten the big end nuts.

NOTICE

The connecting rod bolts are designed to stretch when tightened. Never reuse the connecting rod bolts. See the table below for correct bolt and nut usage.

NOTICE

Be careful not to overtighten the nuts. The bolts must be positioned on the seating surface correctly to prevent the bolt heads from hitting the crankcase.

9-18 CRANKSHAFT/TRANSMISSION

Crankshaft and Connecting Rods

(1) Bolt Length Measurement Method

- Be sure to clean the bolts, nuts, and connecting rods thoroughly with a high-flash point solvent, because the new connecting rods, bolts, and nuts are treated with an anti-rust solution.

⚠ WARNING

Clean the bolts, nuts and connecting rods in a well-ventilated area, and take care that there is no spark or flame anywhere near the working area. This includes any appliance with a pilot light. Because of the danger of highly flammable liquids, do not use gasoline or low-flash point solvents to clean them.

NOTICE

**Immediately dry the bolts and nuts with compressed air after cleaning.
Clean and dry the bolts and nuts completely.**

- Install new bolts and nuts in reused connecting rod.
- ★ If the connecting rod assy was replaced, use the bolts and nuts attached to the new connecting rod assy.
- Apply a small amount of molybdenum disulfide oil solution to the following portions.
 - Threads [A] of Bolts and Nuts
 - Seating Surfaces [B] of Nuts and Connecting Rod Caps

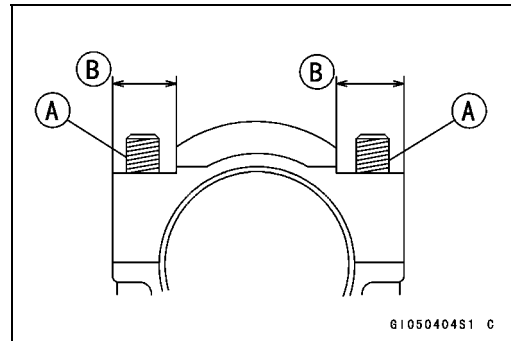

- Dent both bolt head and bolt tip with a punch as shown in the figure.
- Before tightening, use a point micrometer to measure the length of new connecting rod bolts and record the values to find the bolt stretch.
 - Connecting Rod [A]
 - Dent here with a punch [B].
 - Nuts [C]
 - Fit micrometer pins into dents [D].
- Tighten the big end nuts until the bolt elongation reaches the length specified as follows.

$$\text{Bolt Length after tightening} - \text{Bolt Length before tightening} = \text{Bolt Stretch}$$

Connecting Rod Bolt Stretch

Usable Range: 0.20 ~ 0.32 mm (0.0079 ~ 0.0126 in.)

- Check the length of the connecting rod bolts.
- ★ If the stretch is more than the usable range, the bolt has stretched too much. An overelongated bolt may break in use.

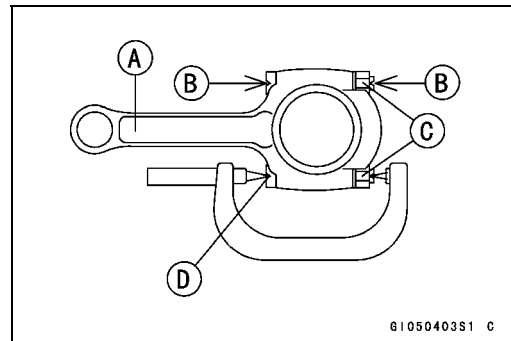

Crankshaft and Connecting Rods

(2) Rotation Angle Method

- ★ If you do not have a point micrometer, you may tighten the nuts using the “Rotation Angle Method”.
- Be sure to clean the bolts, nuts and connecting rods thoroughly with a high-flash point solvent, because the new connecting rods, bolts and nuts are treated with an anti-rust solution.

⚠ WARNING

Gasoline and low-flash point solvents can be flammable and/or explosive and cause severe burns. Clean the bolts, nuts, and connecting rods in a well-ventilated area, and take care that there are no sparks or flame anywhere near the working area; this includes any appliance with a pilot light. Do not use gasoline or a low-flash point solvent to clean them.

NOTICE

Immediately dry the bolts and nuts with compressed air after cleaning. Clean and dry the bolts and nuts completely.

- Install new bolts and nuts in reused connecting rods.
- ★ If the connecting rod assy was replaced, use the bolts and nuts attached to the new connecting rod assy.
- Apply a small amount of molybdenum disulfide oil solution to the following portions.
 - Threads [A] of Bolts and Nuts
 - Seating Surfaces [B] of Nuts and Connecting Rod Caps

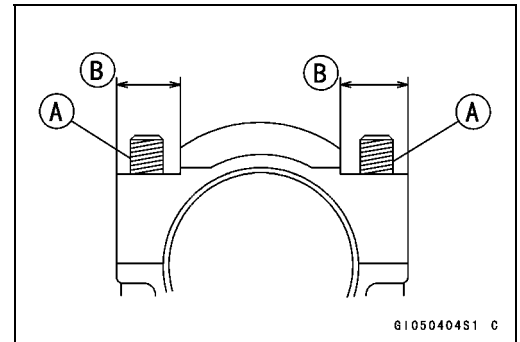

- First, tighten the nuts to the specified torque. See the table below.
- Next, tighten the nuts **120° ±5°**.
- Mark [A] the connecting rod big end caps and nuts so that nuts can be turned 120° [B] properly.
- Tighten the hexagon nut by 2 corners.

Connecting Rod Assy	Bolt	Nut	Torque + Angle N·m (kgf·m, ft·lb)
New	Use the bolts attached to new con-rod.	Attached to new con-rod	22 (2.2, 16) + 120°
		New	20 (2.0, 15) + 120°
Used	Replace the bolts with new ones.	Used	26 (2.7, 19) + 120°
		New	26 (2.7, 19) + 120°

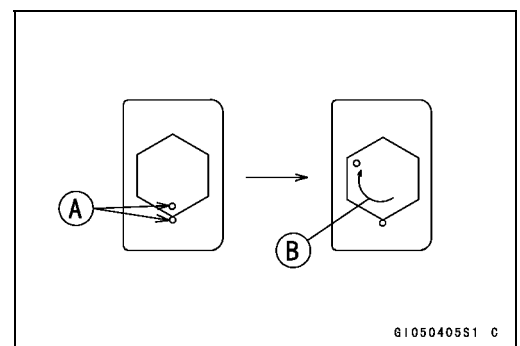

9-20 CRANKSHAFT/TRANSMISSION

Crankshaft and Connecting Rods

Crankshaft/Connecting Rod Cleaning

- After removing the connecting rods from the crankshaft, clean them with a high-flash point solvent.
- Blow the crankshaft oil passages with compressed air to remove any foreign particles or residue that may have accumulated in the passages.

Connecting Rod Bend Inspection

- Remove the connecting rod big end bearing inserts, and reinstall the connecting rod big end cap.
- Select an arbor [A] of the same diameter as the connecting rod big end, and insert the arbor through the connecting rod big end.
- Select an arbor of the same diameter as the piston pin and at least 100 mm (3.94 in.) long, and insert the arbor [B] through the connecting rod small end.
- On a surface plate, set the big-end arbor on V block [C].
- With the connecting rod held vertically, use a height gauge to measure the difference in the height of the arbor above the surface plate over a 100 mm (3.94 in.) length to determine the amount of connecting rod bend.
- ★ If connecting rod bend exceeds the service limit, the connecting rod must be replaced.

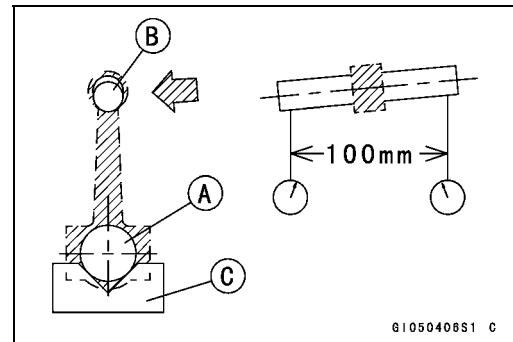

Connecting Rod Bend

Service Limit: TIR 0.2/100 mm (0.008/3.94 in.)

Connecting Rod Twist Inspection

- With the big-end arbor [A] still on V block [C], hold the connecting rod horizontally and measure the amount that the arbor [B] varies from being paralleled with the surface plate over a 100 mm (3.94 in.) length of the arbor to determine the amount of connecting rod twist.
- ★ If connecting rod twist exceeds the service limit, the connecting rod must be replaced.

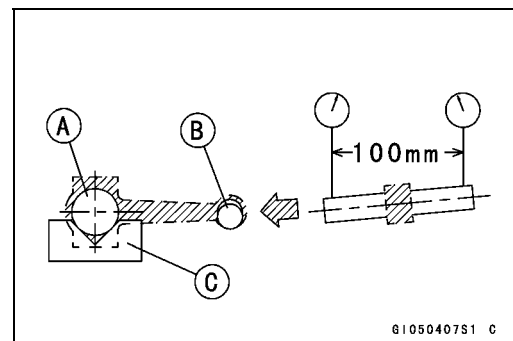

Connecting Rod Twist

Service Limit: TIR 0.2/100 mm (0.008/3.94 in.)

Connecting Rod Big End Side Clearance Inspection

- Measure connecting rod big end side clearance.
- Insert a thickness gauge [A] between the big end and either crank web to determine clearance.

Connecting Rod Big End Side Clearance

Standard: 0.13 ~ 0.38 mm (0.0051 ~ 0.0150 in.)

Service Limit: 0.58 mm (0.023 in.)

- ★ If the clearance exceeds the service limit, replace the connecting rod with new one and then check clearance again. If clearance is too large after connecting rod replacement, the crankshaft also must be replaced.



Crankshaft and Connecting Rods

Connecting Rod Big End Bearing Insert/Crankpin Wear Inspection

- Measure the bearing insert/crankpin [A] clearance with plastigage [B].
- Tighten the big end nuts to the specified torque (see Connecting Rod Installation).

NOTE

○ Do not move the connecting rod and crankshaft during clearance measurement.

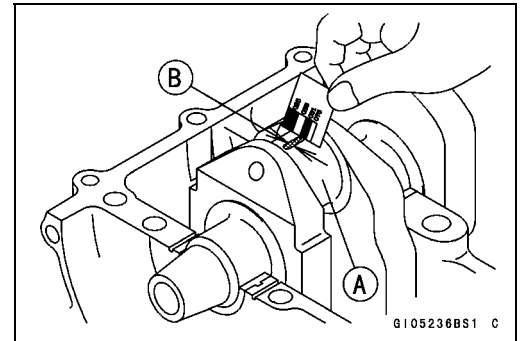

NOTICE

After measurement, replace the connecting rod bolts.

Connecting Rod Big End Bearing Insert/Crankpin Clearance
Standard: 0.030 ~ 0.060 mm (0.0012 ~ 0.0024 in.)
Service Limit: 0.10 mm (0.0039 in.)

- ★ If the clearance is within the standard, no bearing replacement is required.
- ★ If the clearance is between 0.061 mm (0.0024 in.) and the service limit (0.10 mm, 0.0039 in.), replace the bearing inserts [A] with inserts painted blue [B]. Check insert/crankpin clearance with the plastigage. The clearance may exceed the standard slightly, but it must not be less than the minimum in order to avoid bearing seizure.
- ★ If the clearance exceeds the service limit, measure the diameter of the crankpins.

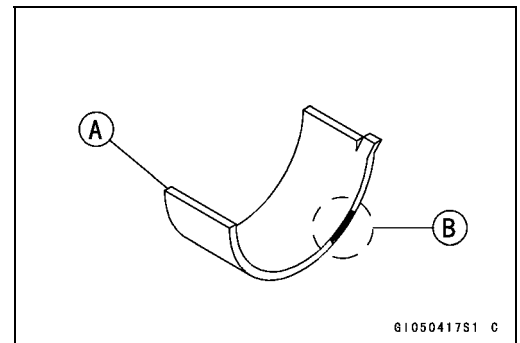

Crankpin Diameter

Standard: 34.484 ~ 34.500 mm (1.3576 ~ 1.3583 in.)
Service Limit: 34.47 mm (1.357 in.)

- ★ If any crankpin has worn past the service limit, replace the crankshaft with a new one.
- ★ If the measured crankpin diameters are not less than the service limit, but do not coincide with the original diameter markings on the crankshaft, make new marks on it.

Crankpin Diameter Marks

None 34.484 ~ 34.492 mm (1.3576 ~ 1.3579 in.)
 ○ **34.493 ~ 34.500 mm (1.3580 ~ 1.3583 in.)**

△: Crankpin Diameter Marks, "○" or no mark.

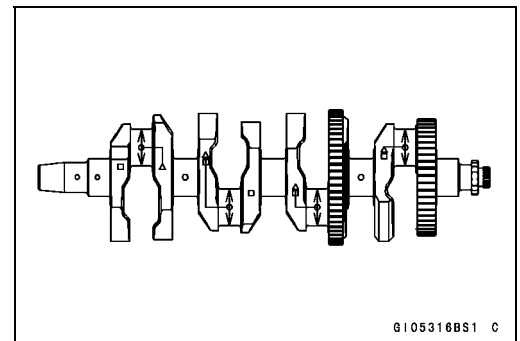

9-22 CRANKSHAFT/TRANSMISSION

Crankshaft and Connecting Rods

- Measure the connecting rod big end inside diameter, and mark each connecting rod big end in accordance with the inside diameter.
- Tighten the connecting rod big end nuts to the specified torque (see Connecting Rod Installation).

NOTE

- *The mark already on the big end should almost coincide with the measurement.*

Connecting Rod Big End Inside Diameter Marks

None 37.500 ~ 37.508 mm (1.4764 ~ 1.4766 in.)

○ 37.509 ~ 37.516 mm (1.4767 ~ 1.4770 in.)

Big End Cap [A]

Connecting Rod [B]

Weight Mark, Alphabet [C]

Diameter Mark (Around Weight Mark) [D]: "○" or no mark

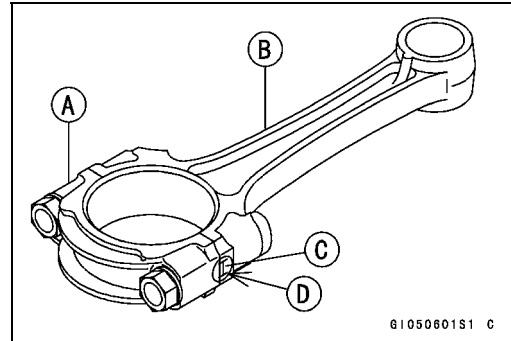

- Select the proper bearing insert [A] in accordance with the combination of the connecting rod and crankshaft coding. Size Color [B]

Con-rod Big End Inside Diameter Marking	Crankpin Diameter Marking	Bearing Insert	
		Size Color	Part Number
None	○	Brown	92139-0124
None	None	Black	92139-0123
○	○		
○	None	Blue	92139-0122

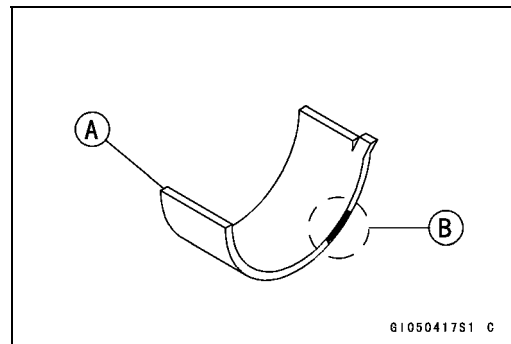

- Install the new inserts in the connecting rod and check insert/crankpin clearance with the plastigage.

Crankshaft Side Clearance Inspection

- Insert a thickness gauge [A] between the crankcase main bearing and the crank web at the No.3 journal to determine clearance.
- ★ If the clearance exceeds the service limit, replace the crankcase halves as a set.

NOTE

- *The upper and lower crankcase halves are machined at the factory in the assembled state, so the crankcase halves must be replaced as a set.*

Crankshaft Side Clearance

Standard: 0.09 ~ 0.19 mm (0.0035 ~ 0.0075 in.)

Service Limit: 0.39 mm (0.0153 in.)

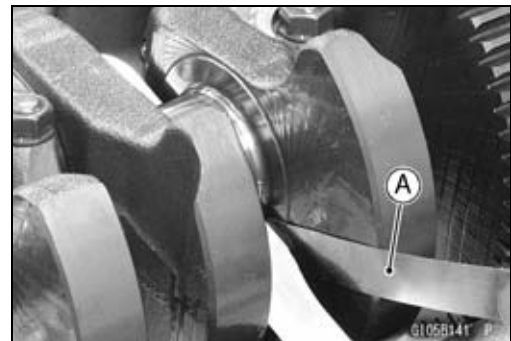

Crankshaft and Connecting Rods

Crankshaft Runout Inspection

- Measure the crankshaft runout.
- ★ If the measurement exceeds the service limit, replace the crankshaft.

Crankshaft Runout

- Standard: TIR 0.02 mm (0.0008 in.) or less
- Service Limit: TIR 0.05 mm (0.0020 in.)

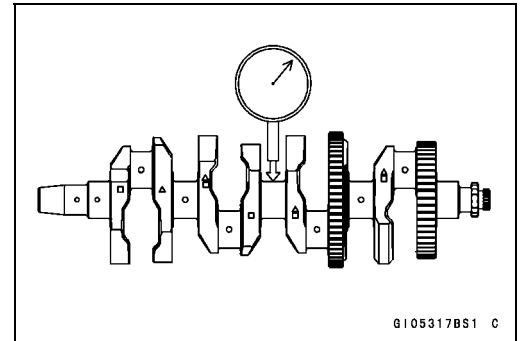

G105317BS1 C

Crankshaft Main Bearing Insert/Journal Wear Inspection

- Using a plastigage (press gauge) [A], measure the bearing insert/journal [B] clearance.

NOTE

- Tighten the crankcase bolts to the specified torque (see Crankcase Assembly).
- Do not turn the crankshaft during clearance measurement.
- Journal clearance less than 0.025 mm (0.00098 in.) can not be measured by plastigage, however, using genuine parts maintains the minimum standard clearance.

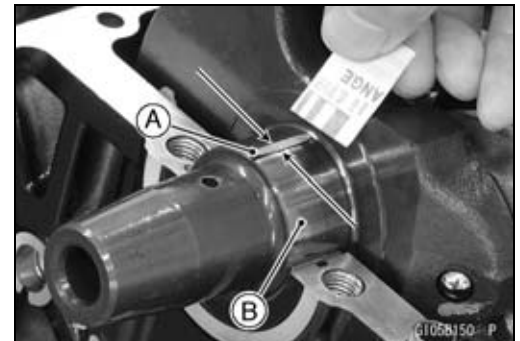

G1053150 P

Crankshaft Main Bearing Insert/Journal Clearance

- Standard: 0.010 ~ 0.034 mm (0.0004 ~ 0.0013 in.)
- Service Limit: 0.06 mm (0.0024 in.)

- ★ If the clearance is within the standard, no bearing replacement is required.
- ★ If the clearance is between 0.035 mm (0.0014 in.) and the service limit (0.06 mm, 0.0024 in.), replace the bearing inserts [A] with inserts painted blue [B]. Check insert/journal clearance with the plastigage. The clearance may exceed the standard slightly, but it must not be less than the minimum in order to avoid bearing seizure.
- ★ If the clearance exceeds the service limit, measure the diameter of the crankshaft main journal.

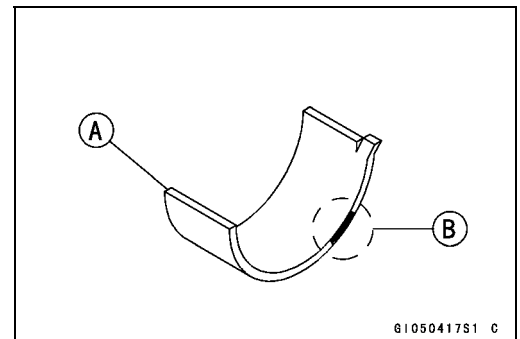

G1050417S1 C

Crankshaft Main Journal Diameter

- Standard: 34.984 ~ 35.000 mm (1.3773 ~ 1.3780 in.)
- Service Limit: 34.96 mm (1.3764 in.)

- ★ If any journal has worn past the service limit, replace the crankshaft with a new one.
- ★ If the measured journal diameters are not less than the service limit, but do not coincide with the original diameter markings on the crankshaft, make new marks on it.

Crankshaft Main Journal Diameter Marks

- None 34.984 ~ 34.992 mm (1.3773 ~ 1.3776 in.)
- 1 34.993 ~ 35.000 mm (1.3777 ~ 1.3780 in.)

□: Crankshaft Main Journal Diameter Marks, "1" or no mark.

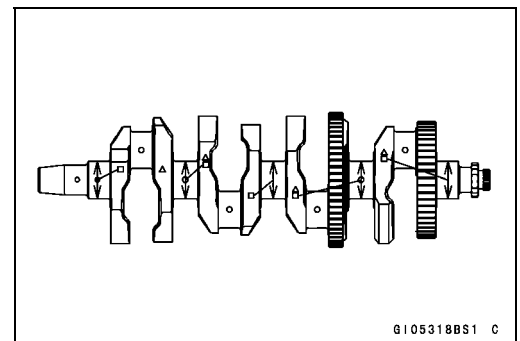

G105318BS1 C

9-24 CRANKSHAFT/TRANSMISSION

Crankshaft and Connecting Rods

- Measure the main bearing inside diameter, and mark the upper crankcase half in accordance with the inside diameter.

Crankcase Main Bearing Inside Diameter Marks: “○” or no mark.

- Tighten the crankcase bolts to the specified torque (see Crankcase Assembly).

NOTE

○ The mark already on the upper crankcase half should almost coincide with the measurement.

Crankcase Main Bearing Inside Diameter Marks

- 38.000 ~ 38.008 mm (1.4961 ~ 1.4963 in.)
- None 38.009 ~ 38.016 mm (1.4964 ~ 1.4967 in.)

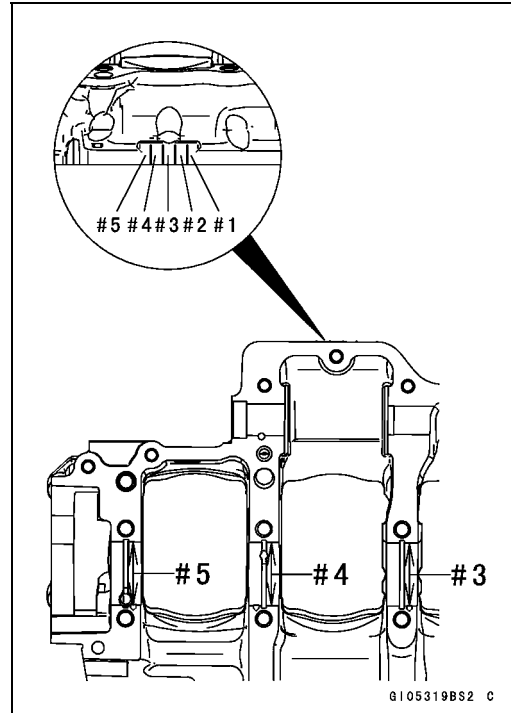

- Select the proper bearing insert [A] in accordance with the combination of the crankcase and crankshaft coding. Size Color [B]

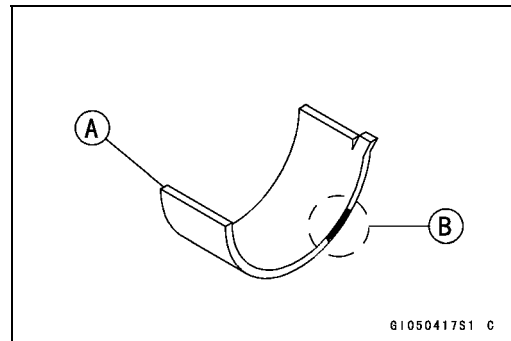

Crankcase Main Bearing Inside Diameter Marking	Crankshaft Main Journal Diameter Marking	Bearing Insert*		
		Size Color	Part Number	Journal Nos.
○	1	Brown	92139-0034	2, 4
			92139-0219	1, 3, 5
None	1	Black	92139-0033	2, 4
○	None		92139-0218	1, 3, 5
None	None	Blue	92139-0032	2, 4
			92139-0217	1, 3, 5

* The bearing inserts for Nos. 2 and 4 journals have an oil groove, respectively.

- Install the new inserts in the crankcase halves and check insert/journal clearance with the plastigage.

Balancer

Balancer Removal

- Split the crankcase (see Crankcase Splitting).
- Unscrew:
 - Balancer Shaft Clamp Bolt [A]
 - Balancer Shaft Lever [B]
 - Oil Seal [C]
- Remove the balancer [D] from the upper crankcase half.

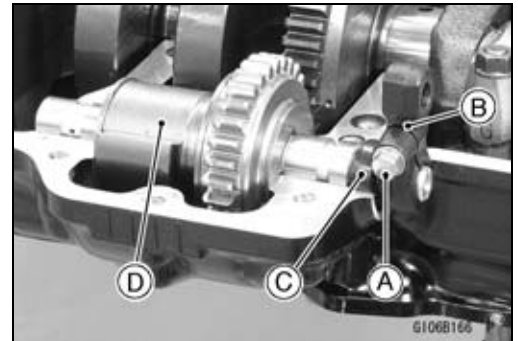

Balancer Installation

- Check that the rubber dampers [A] are in place as shown in the figure.

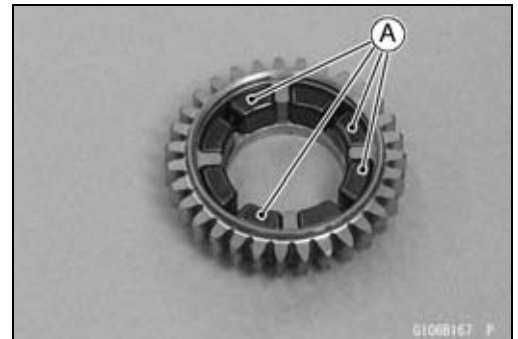

- Apply molybdenum disulfide oil solution to the damper contact portions of the balancer weight.
- Install the balancer weight [A] into the gear [B].
- Align the punch mark [C] of the balancer weight with the groove [D] of the gear.

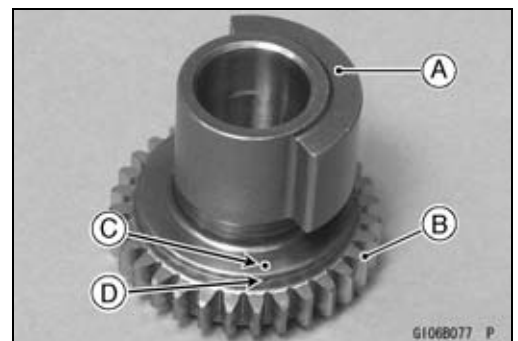

- Apply molybdenum disulfide oil solution to the needle bearings. Insert the needle bearings.
- Fit the copper washers [A] on both ends of the weight and gear assembly. The projected sides [B] face inward.

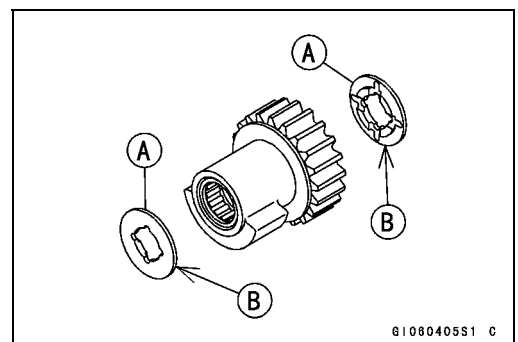

- Insert the pin [A] as shown in the figure.
- Set the balancer on the upper crankcase half.
- Align the punch mark [B] on the balancer gear [C] with the mark [D] on the balancer drive gear [E] of crankshaft.

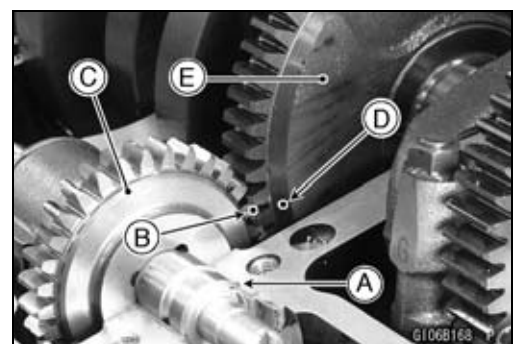

9-26 CRANKSHAFT/TRANSMISSION

Balancer

- Assemble the crankcase (see Crankcase Assembly).
- Fill the oil seal lips with grease.
- Install the new oil seal [A] so that its surface is flush with the surface of the crankcase.
- Turn the balancer shaft so that its mark [B] faces downward (This photo is shown with the upside down).

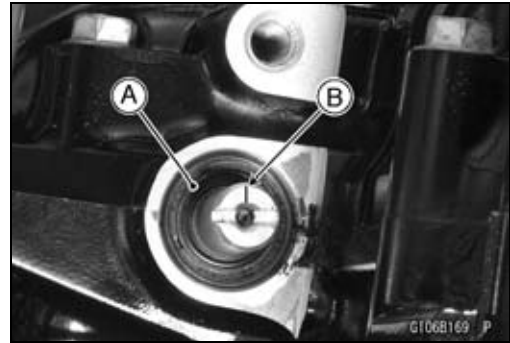

- Install the balancer shaft lever [A].
- Apply a non-permanent locking agent to the threads of the balancer shaft clamp lever bolt [B].
- Tighten:

Torque - Balancer Shaft Clamp Lever Bolt: 25 N·m (2.5 kgf·m, 18 ft·lb)

Balancer Shaft Clamp Bolt [C]: 9.8 N·m (1.0 kgf·m, 87 in·lb)

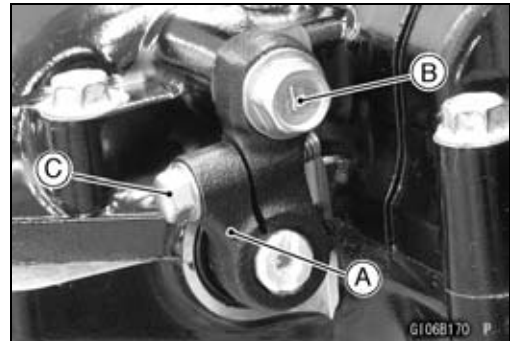

Balancer Adjustment

- Remove the lower fairing (see Lower Fairing Removal in the Frame chapter).
- Start the engine and warm it up thoroughly.
- Adjust the balancer gear backlash with the engine idling. The amount of backlash can be changed by turning the balancer shaft which has eccentric journals.
- Start the engine and let it idle.
- Loosen the clamp bolt [A] and turn the balancer shaft [B] clockwise [C] until the balancer gear makes a whining sound.
- Turn the shaft counterclockwise [D] until the balancer gear whining sound disappears and tighten the clamp bolt.

Torque - Balancer Shaft Clamp Bolts: 9.8 N·m (1.0 kgf·m, 87 in·lb)

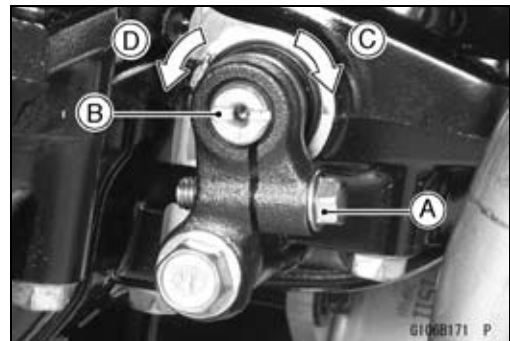

Balancer Damper Inspection

- Remove the balancer and disassemble the weight and gear assembly.
- Visually inspect the rubber dampers [A].
- ★ If they appear damaged or deteriorated, replace them.

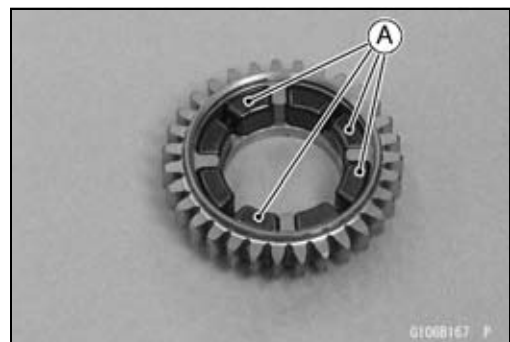

Starter Motor Clutch

Starter Motor Clutch Removal/Installation

- Refer to the Alternator Rotor Removal/Installation in the Electrical System chapter.

Starter Motor Clutch Inspection

- Remove:
 - Alternator Cover (see Alternator Cover Removal in the Electrical System chapter)
 - Starter Idle Gear and Shaft
- Turn the starter motor clutch gear [A] by hand. The starter motor clutch gear should turn clockwise [B] freely, but should not turn counterclockwise [C].
- ★ If the starter motor clutch does not operate as it should or if it makes noise, go to the next step.
- Disassemble the starter motor clutch, and visually inspect the clutch parts.
- ★ If there is any worn or damaged part, replace it.

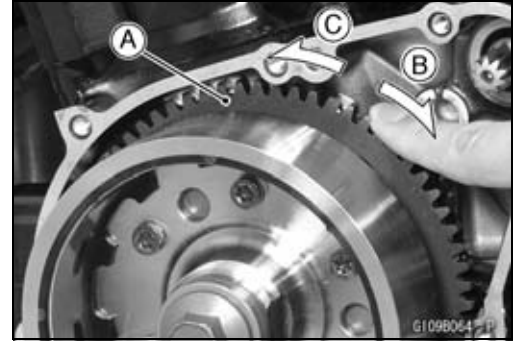

NOTE

○ Examine the starter motor clutch gear as well. Replace it if it worn or damaged.

Starter Motor Clutch Disassembly

- Remove:
 - Alternator Rotor (see Alternator Rotor Removal in the Electrical System chapter)
- Hold the alternator rotor with the flywheel holder [A].
- **Special Tool - Flywheel Holder: 57001-1313**
- Remove the starter motor clutch bolts [B].

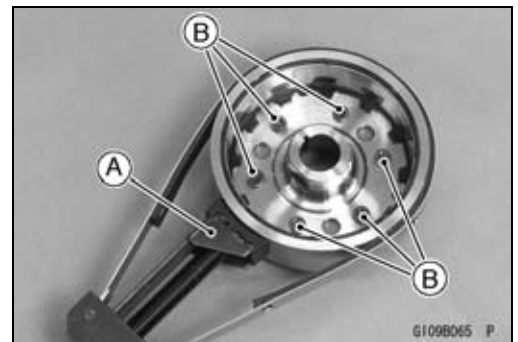

- Remove:
 - Starter Motor Clutch Housing [A]
 - Starter Motor Clutch [B]

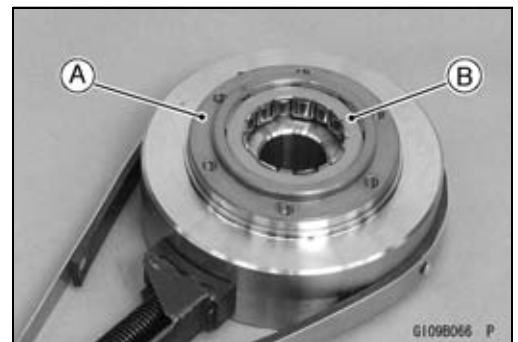

Starter Motor Clutch Assembly

- Install the starter motor clutch to the housing so that the flange [A] fit to the housing groove [B].
- Apply a non-permanent locking agent to the threads of the starter motor clutch bolts and tighten them.

Torque - Starter Motor Clutch Bolts: 12 N·m (1.2 kgf·m, 106 in·lb)

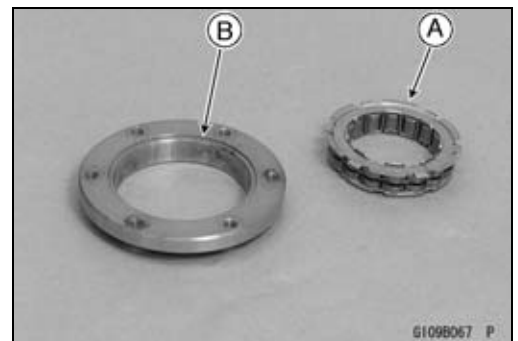

9-28 CRANKSHAFT/TRANSMISSION

External Shift Mechanism

Shift Pedal Removal

- Remove:
 - Shift Lever Bolt [A]
 - Shift Lever [B]
 - Shift Pedal Mounting Bolt [C]
 - Shift Pedal [D] with Tie-rod [E]

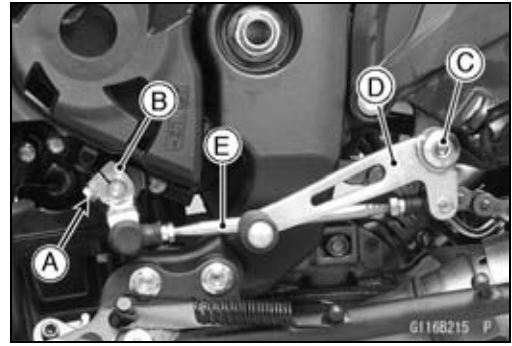

Shift Pedal Installation

- Tighten:
 - Torque - Shift Pedal Mounting Bolt [A]: 25 N·m (2.5 kgf·m, 18 ft·lb)
 - Shift Pedal [B]
 - Washer [C]

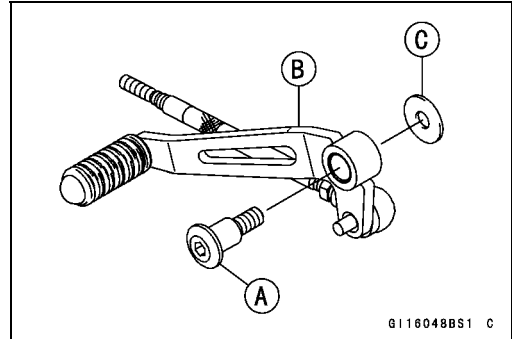

- Align the punch mark [A] on the shift shaft with the slit [B] of the shift lever.
- Tighten the shift lever bolt [C].

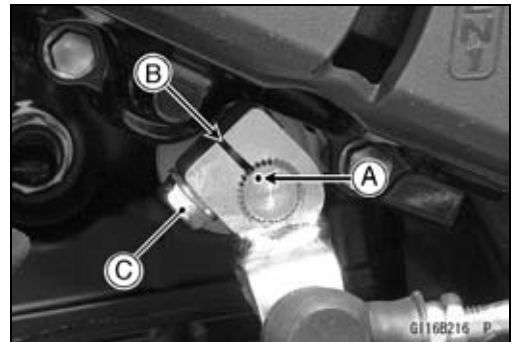

- After installation, confirm that the shift pedal [A] is positioned as shown in the figure.
 - About 90° [B]
- ★ If the pedal position is different, adjust it as follows.
 - To adjust the pedal position, loosen the front locknut [C] (left-hand threads) and rear locknut [D], and then turn the tie-rod [E].

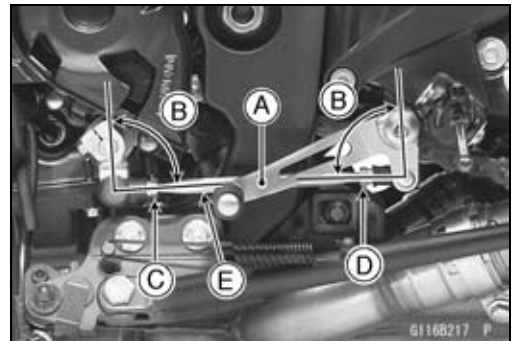

External Shift Mechanism Removal

- Remove:
 - Shift Lever (see Shift Pedal Removal)
 - Circlip [A]
 - Washer [B]
 - Clutch (see Clutch Removal in the Clutch chapter)
- Special Tool - Outside Circlip Pliers: 57001-144

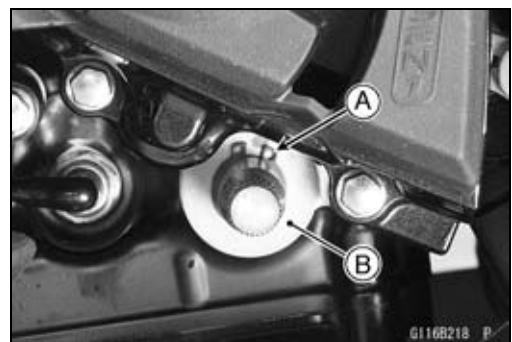

External Shift Mechanism

- Pull out the shift shaft assembly [A].



- Remove:
 Gear Positioning Lever Bolt [A]
 Gear Positioning Lever [B]
 Collar and Spring [C]

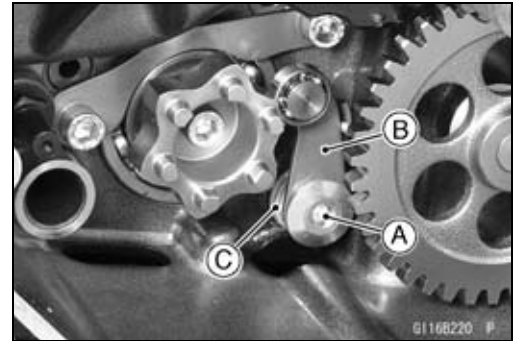

- Remove:
 Shift Drum Cam Bolt [A]
 Shift Drum Cam [B]

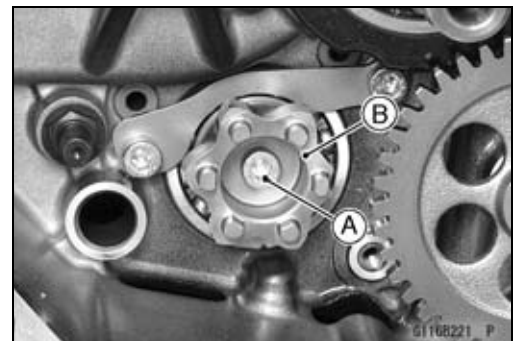

External Shift Mechanism Installation

- Be sure to install the dowel pin [A].
- Align the dowel pin with the hollow [B] of the shift drum cam.
- Apply a non-permanent locking agent to the threads of the shift drum cam bolt, and tighten it.

Torque - Shift Drum Cam Bolt: 12 N·m (1.2 kgf·m, 106 in·lb)

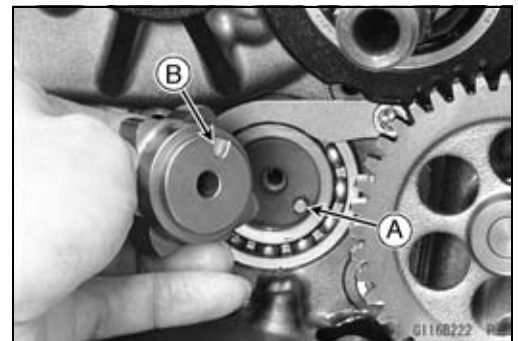

- Assemble the following parts as shown.
 [A] Gear Positioning Lever
 [B] Spring
 [C] Collar
 [D] Gear Positioning Lever Bolt
- Hang the spring end [E] to the gear positioning lever.

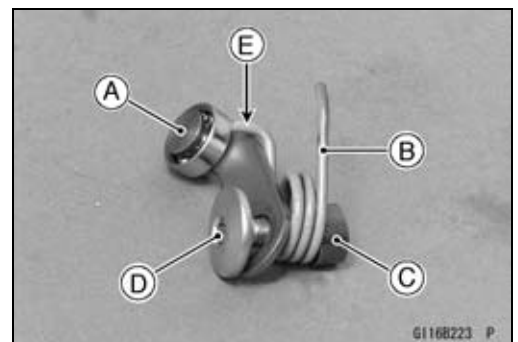

9-30 CRANKSHAFT/TRANSMISSION

External Shift Mechanism

- While prying the gear positioning lever [A], tighten the gear positioning lever bolt [B].

Torque - Gear Positioning Lever Bolt: 12 N·m (1.2 kgf·m, 106 in·lb)

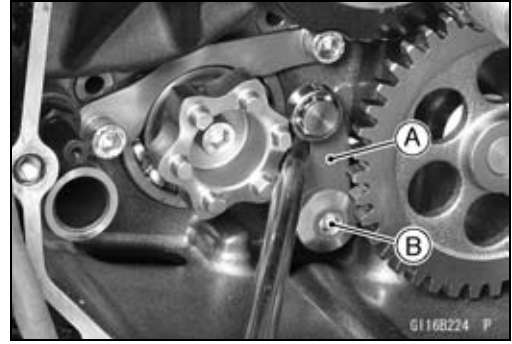

- Install the shift shaft [A] so that the return spring pin [B] fits between the spring [C].

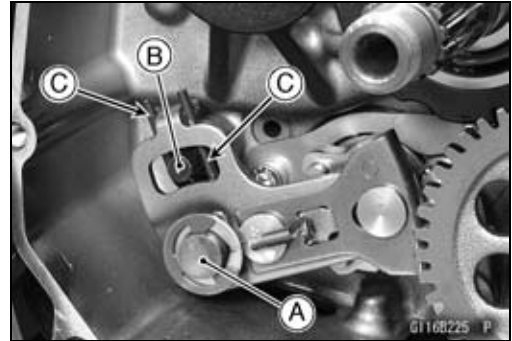

- Install the washer [A].
- Replace the circlip [B] with a new one, and install it.

Special Tool - Out side Circlip Pliers: 57001-144

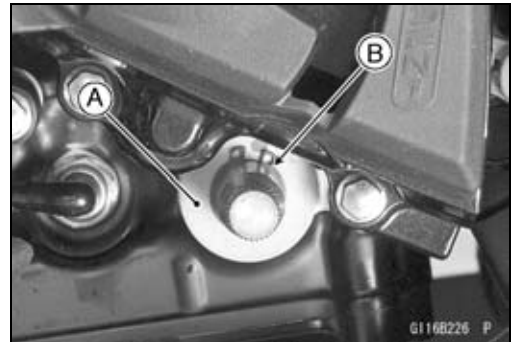

External Shift Mechanism Inspection

- Examine the shift shaft [A] for any damage.
 - ★ If the shaft is bent, straighten or replace it.
 - ★ If the serration [B] are damaged, replace the shaft.
 - ★ If the springs [C] are damaged in any way, replace them.
 - ★ If the shift mechanism arm [D] is damaged in any way, replace the shift shaft.

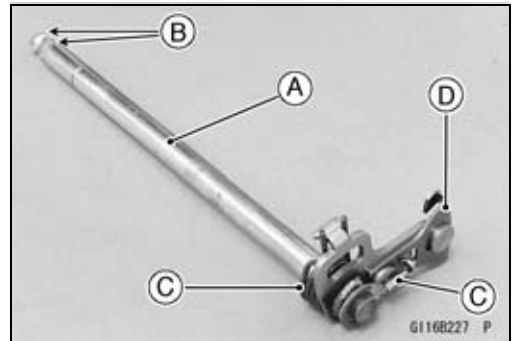

- Check the return spring pin [A] is not loose.
 - ★ If it is loose, unscrew it, apply a non-permanent locking agent to the threads, and tighten it.

Torque - Shift Shaft Return Spring Pin: 39 N·m (4.0 kgf·m, 29 ft·lb)

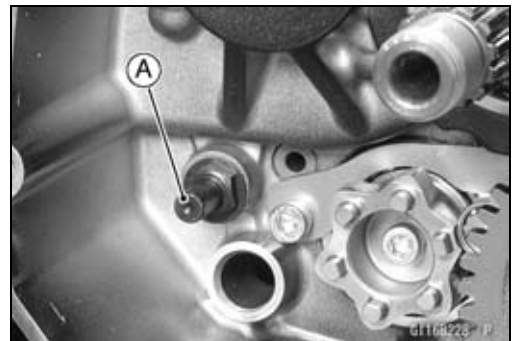

External Shift Mechanism

- Check the gear positioning lever [A] and its spring for breaks or distortion.
- ★ If the lever or spring are damaged in any way, replace them.
- Visually inspect the shift drum cam [B].
- ★ If it is badly worn or shows any damage, replace it.

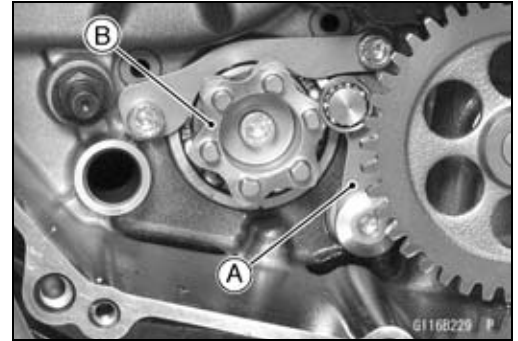

9-32 CRANKSHAFT/TRANSMISSION

Transmission

Transmission Shaft Removal

- Split the crankcase (see Crankcase Splitting).
- Remove the drive shaft [A] and output shaft [B].

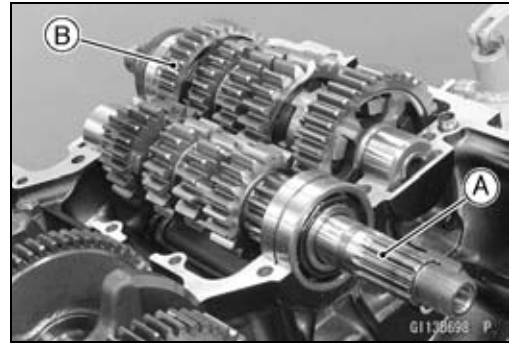

Transmission Shaft Installation

- Check to see that the set pins [A] and set rings [B] are in place.

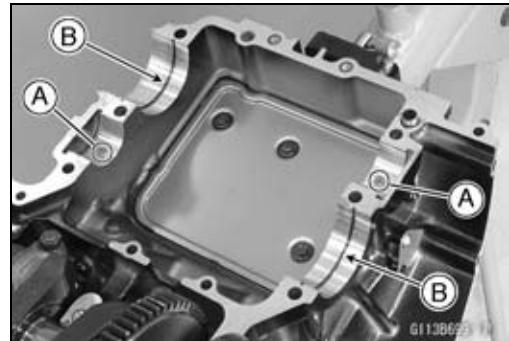

- Install the drive shaft and output shaft into the upper crankcase half.
- Apply engine oil to the bearings.
- The bearing set pins and rings must match properly with the holes or grooves in the bearing outer races. When they are properly matched, there is no clearance [A] between the crankcase and the bearing outer races.

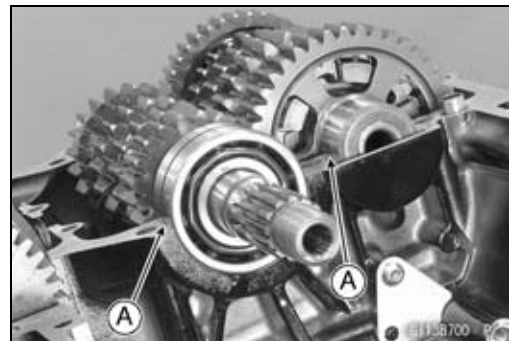

- Assemble the crankcase (see Crankcase Assembly).
- Apply high-temperature grease to the oil seal lips.
- Apply water-soluble lubricant to the out side surface of the oil seal [A].

Sealant - ThreeBond: TB2720C

- Press in the oil seal onto collar [B] so that the surface of the oil seal is flush with the surface [C] of the crankcase.

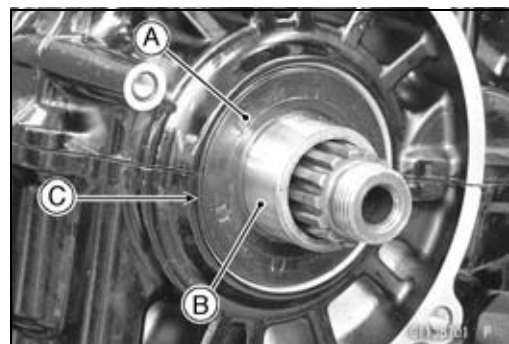

Transmission Shaft Disassembly

- Remove the transmission shafts (see Transmission Shaft Removal).
- Remove the circlips, and disassemble the transmission shafts.

Special Tool - Outside Circlip Pliers: 57001-144

- The 5th gear [A] on the output shaft has three steel balls assembled into it for the positive neutral finder mechanism. Remove the 5th gear.
- Set the output shaft in a vertical position holding the 3rd gear [B].
- Spin the 5th gear quickly [C] and pull it off upward.

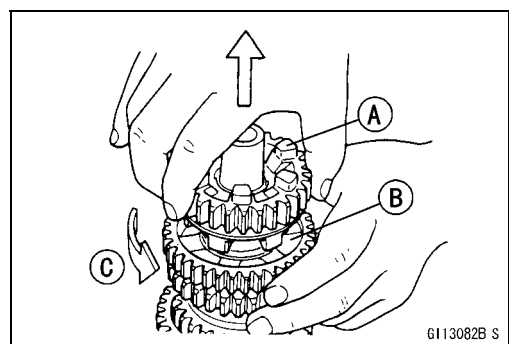

Transmission

- Remove the ball bearing [A] from each shafts.

Special Tools - Bearing Puller [C]: 57001-135

Bearing Puller Adapter [D]: 57001-317

- Discard the bearing.
- For output shaft, remove the collar [B] together with the ball bearing.

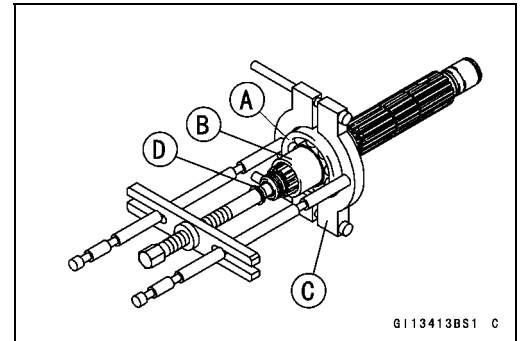

Transmission Shaft Assembly

- Install the new ball bearing [A] and collar [B] (output shaft) on the each shaft, using the bearing driver.

Spacial Tool - Bearing Driver, ϕ 32: 57001-382

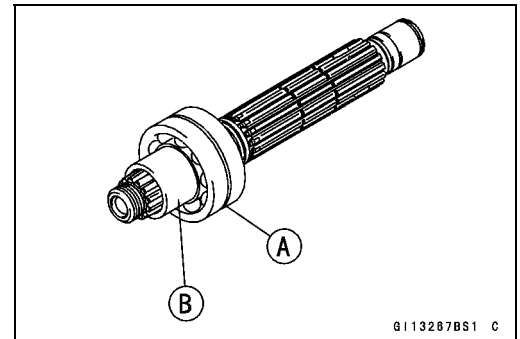

- Apply engine oil to the bushings, ball bearings and shafts.
- Install the gear bushings [A] on the shaft with their holes [B] aligned.

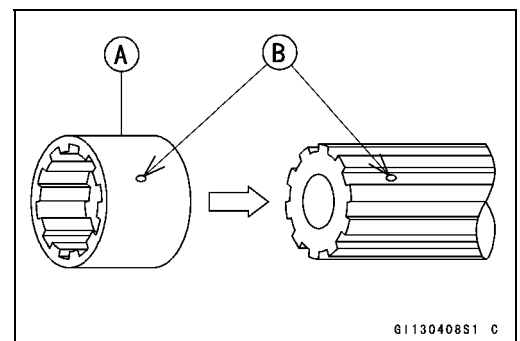

- Replace any circlips removed with new ones.
- Install the circlips [A] so that the opening [B] is aligned with a spline groove [C].

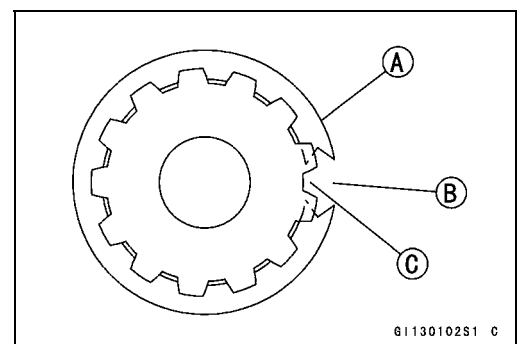

9-34 CRANKSHAFT/TRANSMISSION

Transmission

- The drive shaft gears can be recognized by size: the gear with the smallest diameter is 1st gear, and the largest one is 6th gear. Be sure that all parts are put back in the correct sequence and all circlips and washers are properly in place.
- Install the 3rd/4th gear onto the drive shaft with their oil holes aligned.
- Install the 6th gear bushing onto the drive shaft with their oil holes aligned.
- The output shaft gears can be recognized by size: the gear with the largest diameter is 1st gear, and the smallest one is 6th gear. Be sure that all parts are put back in the correct sequence and all circlips and washers are properly in place.
- Install the 6th gear onto the output shaft with their oil holes aligned.
- Install the 3rd/4th gear bushings onto the output shaft with their oil holes aligned.

NOTE

- When the toothed washers are assembled onto the output shaft, note the following.
- When the tangs [A] of the toothed washer shall be assembled, they should be installed into the notch [B] of the toothed washer (see Page 9-36).

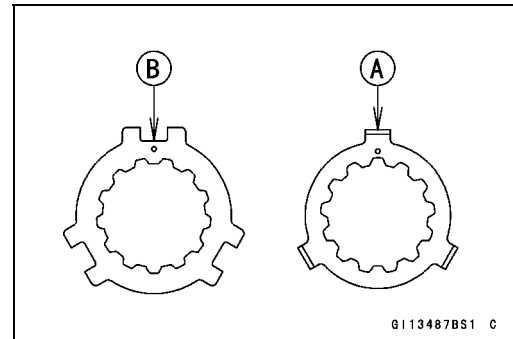

- Fit the steel balls into the 5th gear holes in the output shaft, aligning the hole as shown in the figure.
5th Gear [A]
Output Shaft [B]
Steel Balls [C]
Hole [D]

NOTICE

Do not apply grease to the balls to hold them in place. This will cause the positive neutral finder mechanism to malfunction.

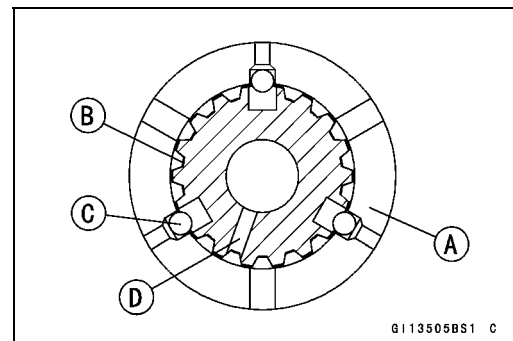

- After assembling the 5th gear with steel balls in place on the output shaft, check the ball-locking effect that the 5th gear doesn't come out of the output shaft when moving it up and down by hand.
- Check that each gear spins or slides freely on the transmission shafts without binding after assembly.

Transmission

This page intentionally left blank.

9-36 CRANKSHAFT/TRANSMISSION

Transmission

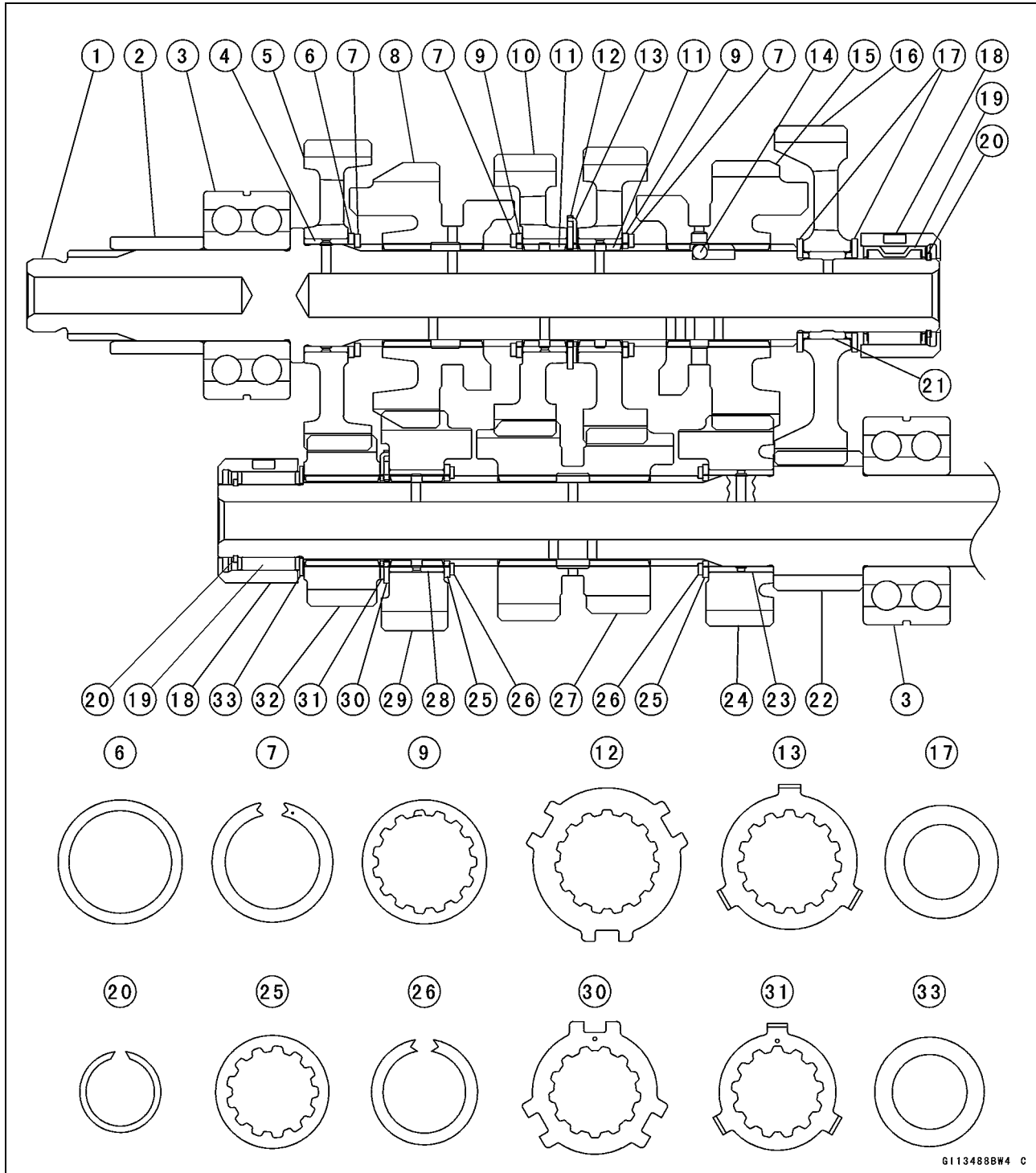

Transmission

1. Output Shaft
2. Collar
3. Bearing
4. Bushing
5. 2nd Gear (39 T)
6. Washer ($\phi 34 \times \phi 28.1$)
7. Circlips ($\phi 33 \times \phi 25.9$)
8. Top Gear (25 T)
9. Toothed Washer ($\phi 34$)
10. 4th/3rd Gear (25 T/24 T)
11. Bushing
12. Toothed Washer ($\phi 40.5$)
13. Toothed Washer ($\phi 37$)
14. Steel Balls
15. 5th Gear (26 T)
16. Low Gear (39 T)
17. Washers ($\phi 31 \times \phi 20.5$)
18. Races
19. Needle Bearings
20. Circlips ($\phi 22.2 \times \phi 18.7$)
21. Needle Bearing
22. Low Gear (15 T) (Drive Shaft)
23. Bushing
24. 5th Gear (21 T)
25. Toothed Washer ($\phi 31$)
26. Circlip ($\phi 29 \times \phi 22.6$)
27. 3rd/4th Gear (15 T/18 T)
28. Bushing
29. Top Gear (22 T)
30. Toothed Washer ($\phi 34.2$)
31. Toothed Washer ($\phi 32$)
32. 2nd Gear (20 T)
33. Washer ($\phi 30 \times \phi 20.5$)

9-38 CRANKSHAFT/TRANSMISSION

Transmission

Shift Drum and Fork Removal

- Remove:
 - Lower Crankcase Half (see Crankcase Splitting)
 - Transmission Shafts (see Transmission Shaft Removal)
 - Gear Positioning Lever (see External Shift Mechanism Removal)
 - Bolts [A]
 - Shift Drum Bearing Holder [B]
- Pull out the shift rods [C], and take off the shift forks.
- Pull out the shift drum [D].

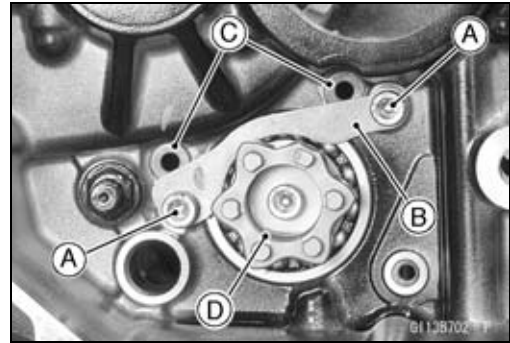

Shift Drum and Fork Installation

- Apply engine oil to the shift drum, forks and rods.
- Install the shift rods [A], noting the groove position.
- The rods are identical.
- Position the one with shortest ears [B] on the drive shaft and place the pin in the center groove in the shift drum [C].
- The two forks [D] on the output shaft are identical.
- Install the forks so that its "0061" and "0062" side faces engine left side.
- Apply a non-permanent locking agent to the threads of the shift drum bearing holder bolts, and tighten them.

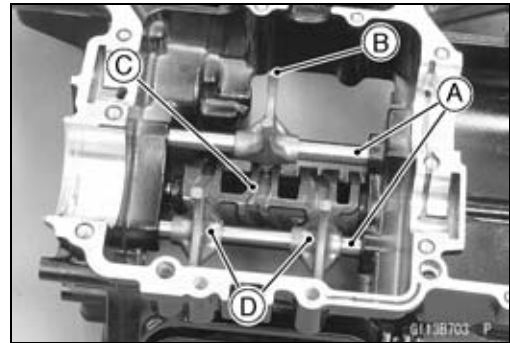

Torque - Shift Drum Bearing Holder Bolts: 12 N·m (1.2 kgf·m, 106 in·lb)

Shift Drum Disassembly

- Remove the shift drum (see Shift Drum and Fork Removal).
- While holding the shift drum with a vise, remove the shift drum cam bolt [A].
- Remove:
 - Shift Drum Cam [B]
 - Dowel Pin [C]
 - Bearing [D]

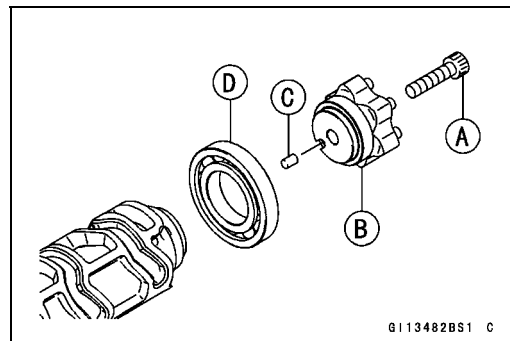

Shift Drum Assembly

- Be sure to install the dowel pin.
- Apply a non-permanent locking agent to the threads of the shift drum bearing holder bolt, and tighten it.

Torque - Shift Drum Cam Bolt: 12 N·m (1.2 kgf·m, 106 in·lb)

Shift Fork Bending Inspection

- Visually inspect the shift forks, and replace any fork that is bent. A bent fork could cause difficulty in shifting, or allow the transmission to jump out of gear when under power.
- 90° [A]

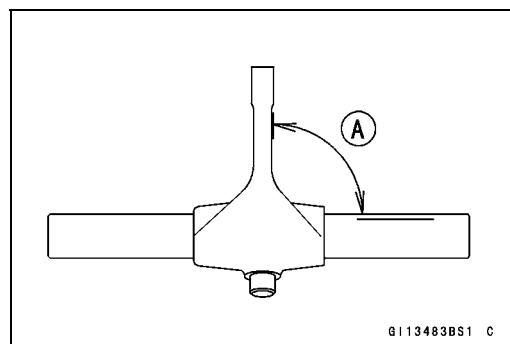

Transmission

Shift Fork/Gear Groove Wear Inspection

- Measure the thickness of the shift fork ears [A], and measure the width of the gear grooves [B].
- ★ If the thickness of a shift fork ear is less than the service limit, the shift fork must be replaced.

Shift Fork Ear Thickness

Standard: 5.9 ~ 6.0 mm (0.232 ~ 0.236 in.)

Service Limit: 5.8 mm (0.228 in.)

- ★ If the gear groove is worn over the service limit, the gear must be replaced.

Gear Groove Width

Standard: 6.05 ~ 6.15 mm (0.238 ~ 0.242 in.)

Service Limit: 6.25 mm (0.246 in.)

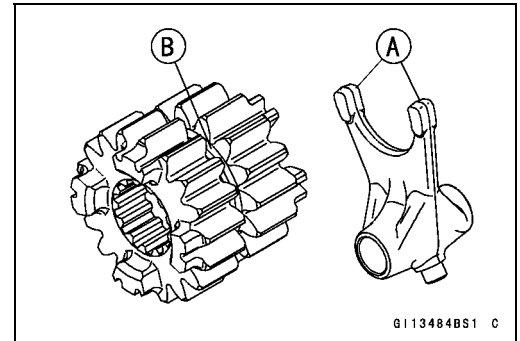

Shift Fork Guide Pin/Drum Groove Wear Inspection

- Measure the diameter of each shift fork guide pin [A], and measure the width of each shift drum groove [B].
- ★ If the guide pin on any shift fork is less than the service limit, the fork must be replaced.

Shift Fork Guide Pin Diameter

Standard: 6.9 ~ 7.0 mm (0.272 ~ 0.276 in.)

Service Limit: 6.8 mm (0.268 in.)

- ★ If any shift drum groove is worn over the service limit, the drum must be replaced.

Shift Drum Groove Width

Standard: 7.05 ~ 7.20 mm (0.278 ~ 0.283 in.)

Service Limit: 7.3 mm (0.287 in.)

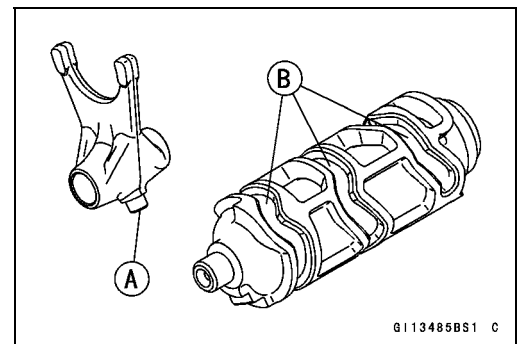

Gear Dog and Gear Dog Hole Damage Inspection

- Visually inspect the gear dogs [A] and gear dog holes [B].
- ★ Replace any damaged gears or gears with excessively worn dogs or dog holes.

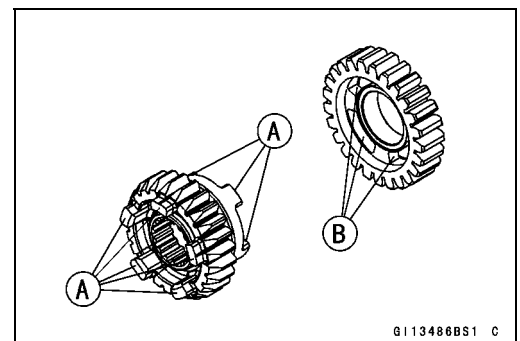

9-40 CRANKSHAFT/TRANSMISSION

Ball Bearing, Needle Bearing, and Oil Seal

Ball and Needle Bearing Replacement

NOTICE

Do not remove the ball or needle bearings unless it is necessary. Removal may damage them.

- Using a press or puller, remove the ball bearing and/or needle bearings.

NOTE

○ In the absence of the above mentioned tools, satisfactory results may be obtained by heating the case to approximately 93°C (200°F) max., and tapping the bearing in or out.

NOTICE

Do not heat the case with a torch. This will warp the case. Soak the case in oil and heat the oil.

- Using a press and the bearing driver set [A], install the new ball bearing until it stops at the bottom of its housing.
- The new needle bearings must be pressed into the crankcase so that the end is flush with the end of the hole.

Special Tool - Bearing Driver Set: 57001-1129

Ball and Needle Bearing Wear

NOTICE

Do not remove the bearings for inspection. Removal may damage them.

- Check the ball bearings.
- Since the ball bearings are made to extremely close tolerances, the wear must be judged by feel rather than measurement. Clean each bearing in a high-flash point solvent, dry it (do not spin the bearing while it is dry), and oil it with engine oil.
- Spin [A] the bearing by hand to check its condition.
- ★ If the bearing is noisy, does not spin smoothly, or has any rough spots, replace it.
- Check the needle bearings.
- The rollers in a needle bearing normally wear very little, and wear is difficult to measure. Instead of measuring, inspect the bearing for abrasion, color change, or other damage.
- ★ If there is any doubt as to the condition of a needle bearing, replace it.

Oil Seal Inspection

- Inspect the oil seals.
- ★ Replace it if the lips are misshapen, discolored (indicating that the rubber has deteriorated), hardened or otherwise damaged.

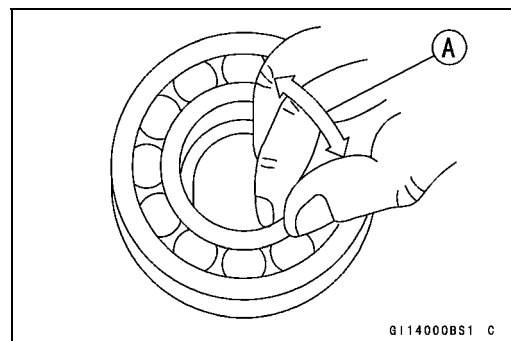
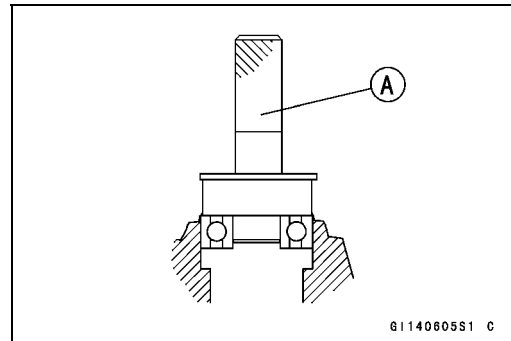

Wheels/Tires

Table of Contents

Exploded View.....	10-2
Specifications	10-4
Special Tools	10-5
Wheels (Rims).....	10-6
Front Wheel Removal	10-6
Front Wheel Installation	10-6
Rear Wheel Removal.....	10-7
Rear Wheel Installation.....	10-9
Wheel Inspection	10-10
Axle Inspection.....	10-10
Balance Inspection.....	10-11
Balance Adjustment.....	10-11
Balance Weight Removal.....	10-11
Balance Weight Installation.....	10-11
Tires.....	10-13
Air Pressure Inspection/Adjustment.....	10-13
Tire Inspection	10-13
Tire Removal.....	10-13
Tire Installation.....	10-13
Tire Repair	10-15
Hub Bearing.....	10-16
Hub Bearing Removal.....	10-16
Hub Bearing Installation.....	10-16
Hub Bearing Inspection.....	10-17
Hub Bearing Lubrication	10-17

10-2 WHEELS/TIRES

Exploded View

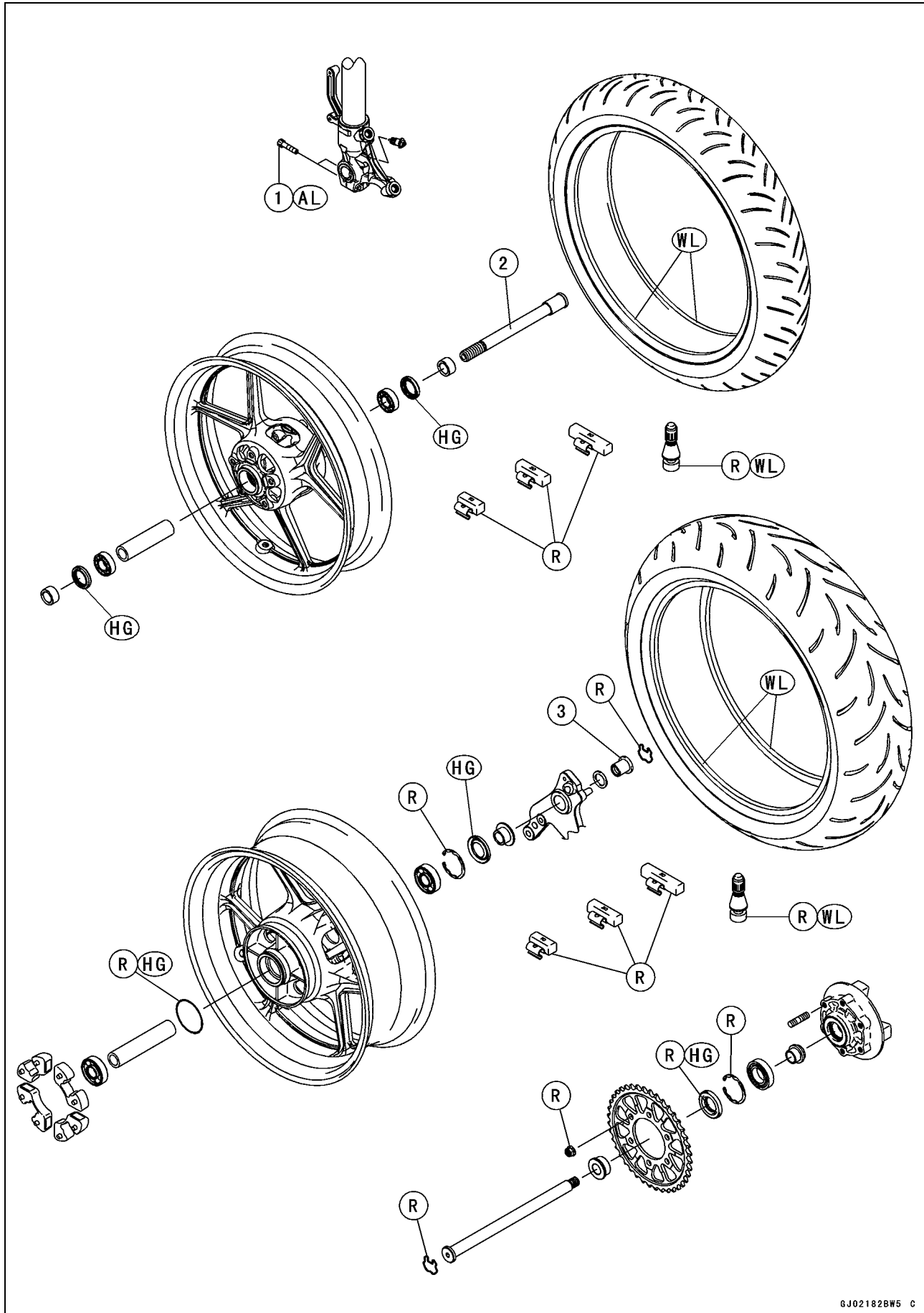

Exploded View

No.	Fastener	Torque			Remarks
		N·m	kgf·m	ft·lb	
1	Front Axle Clamp Bolt	20	2.0	15	AL
2	Front Axle	108	11.0	79.7	
3	Rear Axle Nut	98	10	72	

AL: Tighten the two clamp bolts alternately two times to ensure even tightening torque.

HG: Apply high-temperature grease.

R: Replacement Parts

WL: Apply soap and water solution or rubber lubricant.

10-4 WHEELS/TIRES

Specifications

Item	Standard	Service Limit
Wheels (Rims)		
Rim Runout:		
Axial	TIR 0.5 mm (0.02 in.) or less	TIR 1.0 mm (0.04 in.)
Radial	TIR 0.8 mm (0.03 in.) or less	TIR 1.0 mm (0.04 in.)
Axle Runout/100 mm (3.94 in.)	TIR 0.1 mm (0.004 in.) or less	TIR 0.2 mm (0.008 in.)
Wheel Balance	10 g (0.35 oz.) or less	— — —
Balance Weights	10 g (0.35 oz.), 20 g (0.71 oz.), 30 g (1.06 oz.)	— — —
Rim Size:		
Front	J17M/C × MT3.50	— — —
Rear	J17M/C × MT6.00	— — —
Tires		
Air Pressure (when Cold):		
Front	Up to 180 kg (397 lb) load: 250 kPa (2.5 kgf/cm ² , 36 psi)	— — —
Rear	Up to 180 kg (397 lb) load: 290 kPa (2.9 kgf/cm ² , 42 psi)	— — —
Tread Depth:		
Front	3.6 mm (0.14 in.)	1 mm (0.04 in.) (AT, CH, DE) 1.6 mm (0.06 in.)
Rear	5.3 mm (0.21 in.)	Up to 130 km/h (80 mph): 2 mm (0.08 in.) Over 130 km/h (80 mph): 3 mm (0.12 in.)
Standard Tires:	Make, Type	Size
Front	BRIDGESTONE, BATTLAX BT016F BB	120/70 ZR17 M/C (58 W)
Rear	BRIDGESTONE, BATTLAX BT016R BB	190/50 ZR17 M/C (73 W)

WARNING

Some replacement tires may adversely affect handling and cause an accident resulting in serious injury or death. To ensure proper handling and stability, use only the recommended standard tires for replacement, inflated to the standard pressure.

Special Tools

Inside Circlip Pliers:
57001-143

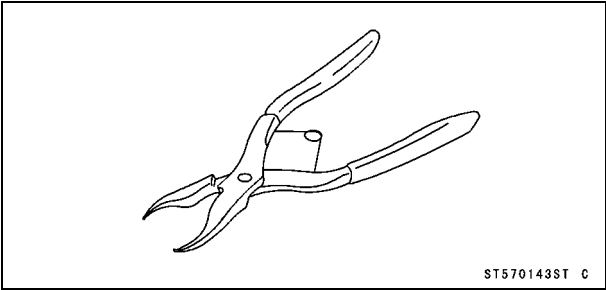

Bearing Remover Head, $\phi 20 \times \phi 22$:
57001-1293

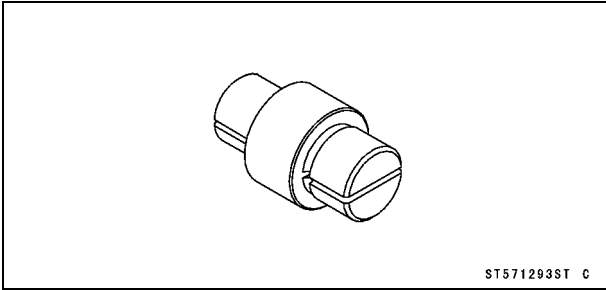

Bearing Driver Set:
57001-1129

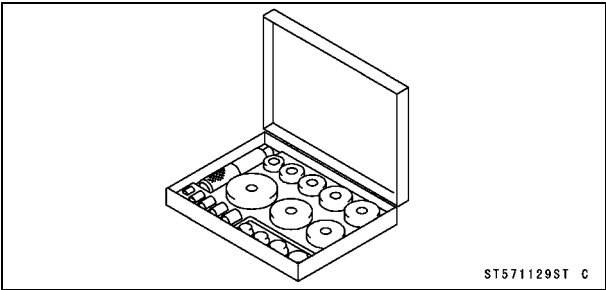

Bearing Remover Shaft, $\phi 13$:
57001-1377

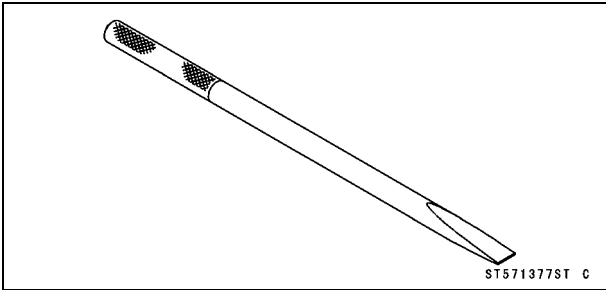

Jack:
57001-1238

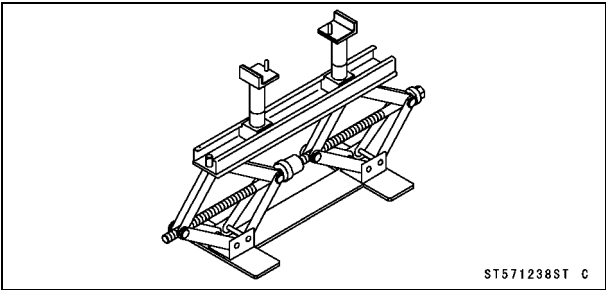

Jack Attachment:
57001-1608

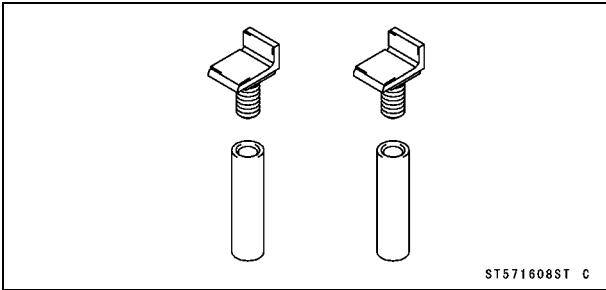

Attachment Jack:
57001-1252

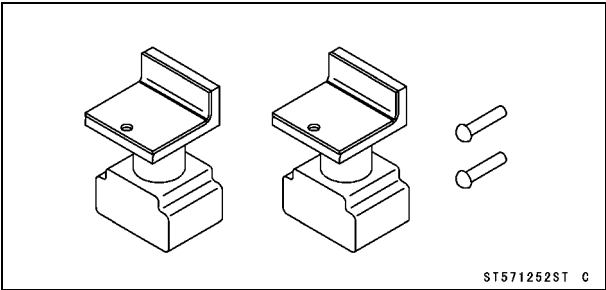

10-6 WHEELS/TIRES

Wheels (Rims)

Front Wheel Removal

- Remove:
 - Front Caliper Mounting Bolts [A] (Both Sides)
 - Front Calipers [B] (Both Sides)
 - Lower Fairing (see Lower Fairing Removal in the Frame chapter)
 - Front Fender (see Front Fender Removal in the Frame chapter)
- For the ABS equipped Models, remove the bolt [C] and front wheel rotation sensor [D].

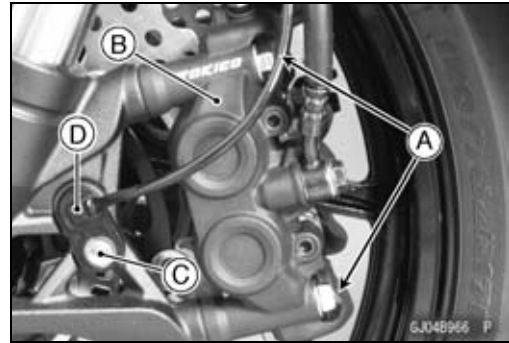

- Loosen:
 - Front Axle Clamp Bolts [A] (Loosen)
 - Front Axle [B]

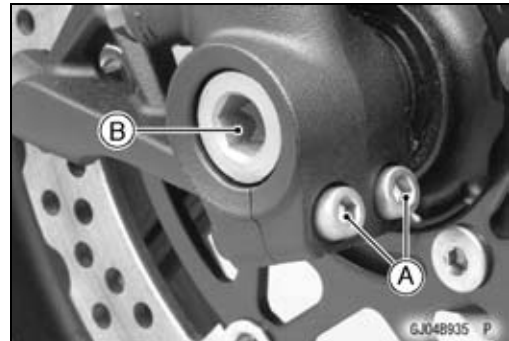

- For the oxygen sensor equipped Models, remove the oxygen sensor (see Oxygen Sensor Removal (Equipped Models) in the Electrical System chapter).
- Raise the front wheel off the ground.

Special Tools - Jack [A]: 57001-1238

Attachment Jack [B]: 57001-1252

Jack Attachment [C]: 57001-1608

- Pull out the axle to the right and drop the front wheel out of the forks.

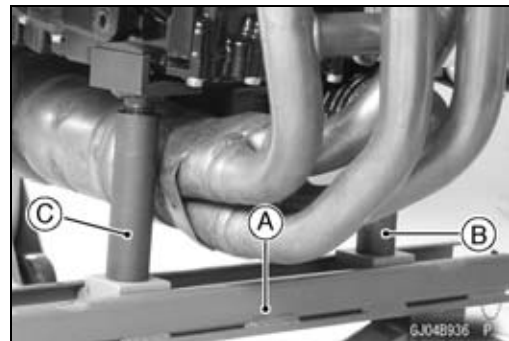

NOTICE

Do not lay the wheel down on one of the discs. This can damage or warp the disc. Place blocks under the wheel so that the disc does not touch the ground.

Front Wheel Installation

NOTE

○ The direction of the wheel rotation [A] is shown by an arrow [B] on the wheel spoke.

- Check the wheel rotation mark on the front wheel and install it.

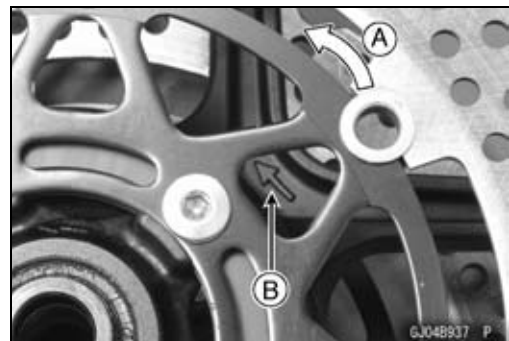

Wheels (Rims)

- Apply high-temperature grease to the grease seal lips.
- Fit the collars [A] on the both sides of the hub.
- The collars are identical.
- Insert the front axle.
- Tighten:
 - Torque - Front Axle: 108 N·m (11.0 kgf·m, 79.7 ft·lb)

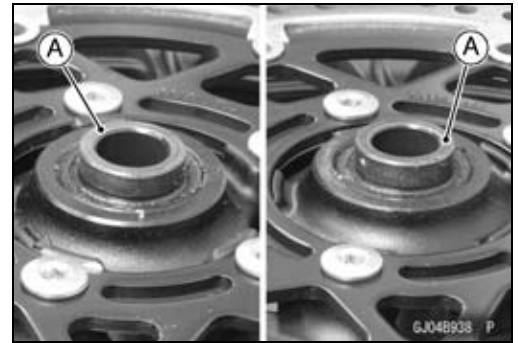

- Before tightening the axle clamp bolts [A] on the right front fork leg, pump the front fork up and down 4 or 5 times to allow the right front fork leg to seat on the front axle.

NOTE

○ Put a block in front of the front wheel to stop moving.

- Tighten:
 - Torque - Front Axle Clamp Bolts: 20 N·m (2.0 kgf·m, 15 ft·lb)

NOTE

○ Tighten the two clamp bolts alternately two times to ensure even tightening torque.

- Install the removed parts (see appropriate chapters).
- Check the front brake effectiveness (see Brake Operation Inspection in the Periodic Maintenance chapter).

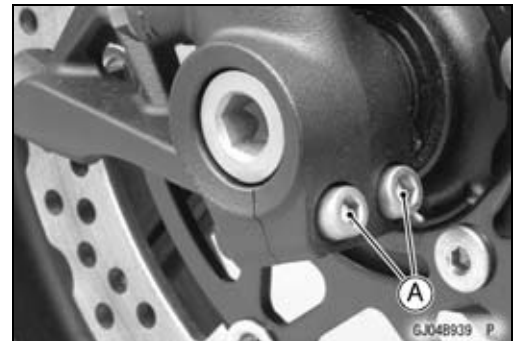

WARNING

After servicing, it takes several applications of the brake lever before the brake pads contact the disc, which could result in increased stopping distance and cause an accident resulting in injury or death. Do not attempt to ride the motorcycle until a firm brake lever is obtained by pumping the lever until the pads are against the disc.

Rear Wheel Removal

- Raise the rear wheel off the ground with the stand [A].



10-8 WHEELS/TIRES

Wheels (Rims)

- Loosen the torque link nuts [A] lightly for chain adjuster turn easily.



- Remove:
 - Rear Caliper Mounting Bolts [A]
 - Rear Caliper [B]

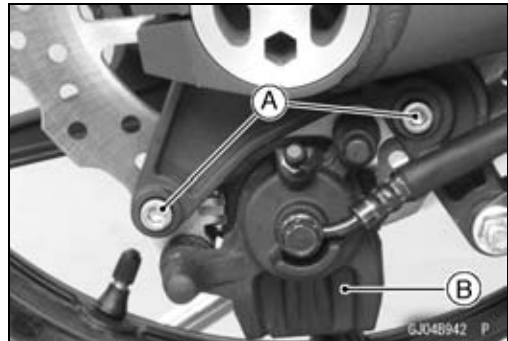

- For ABS equipped Models, remove the bolt [A], clamp [B] and rear wheel rotation sensor [C].

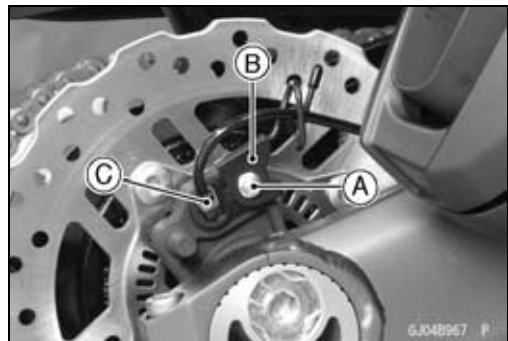

- Loosen the chain adjuster clamp bolts [A] (Both Sides).
- Turn the chain adjuster [B] to make the chain slack.
- Remove:
 - Retaining Rings [C] (Both Sides)
 - Rear Axle Nut [D]
 - Washer

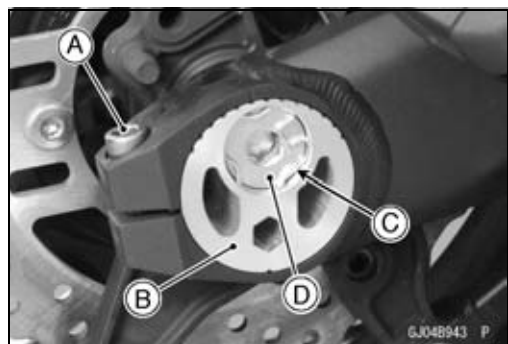

- Remove:
 - Rear Axle [A] (from Left Side)

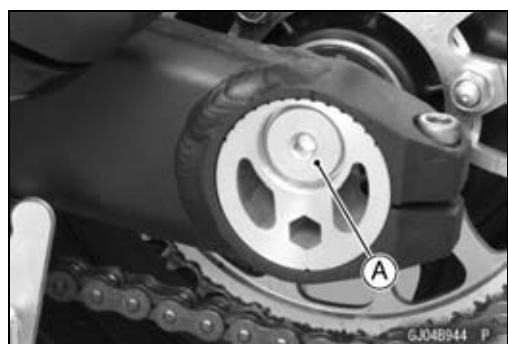

Wheels (Rims)

- Remove the drive chain [A] from the rear sprocket toward the left.
- Move the rear wheel back and remove it.

NOTICE

Do not lay the wheel on the ground with the disc facing down. This can damage or warp the disc. Place blocks under the wheel so that the disc does not touch the ground.



Rear Wheel Installation

- Apply high-temperature grease to the grease seal lips.
- Fit the collars on the both sides of the hub.
 - Left Side Collar [A] ($\phi 40 \times \phi 35$)
 - Right Side Collar [B] ($\phi 44 \times \phi 28$)



- Engage the drive chain with the rear sprocket.
- Insert the axle from the left side of the wheel.
- Align the hole of the brake holder with hole of the rear wheel.
- Install:
 - Washer
 - Rear Axle Nut [A]
- Before tightening the rear axle nut, check that the scale on the left and right adjusters set the same position.
- Tighten:

Torque - Rear Axle Nut: 98 N·m (10 kgf·m, 72 ft·lb)

- Replace the retaining rings [B] with new ones, and install them.

- Adjust the drive chain slack after installation (see Drive Chain Slack Inspection in the Periodic Maintenance chapter).

- Tighten:

Torque - Torque Link Nuts: 34 N·m (3.5 kgf·m, 25 ft·lb)

- Install the rear caliper (see Caliper Installation in the Brakes chapter).
- Check the rear brake effectiveness (see Brake Operation Inspection in the Periodic Maintenance chapter).

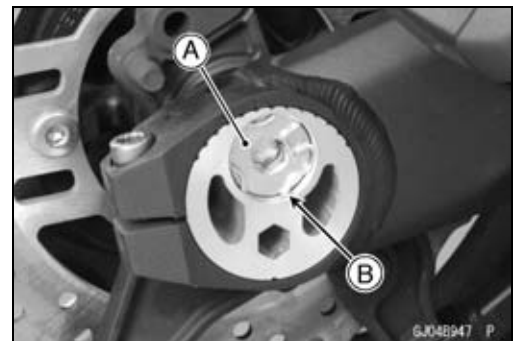

⚠ WARNING

After servicing, it takes several applications of the brake pedal before the brake pads contact the disc, which could result in increased stopping distance and cause an accident resulting in injury or death. Do not attempt to ride the motorcycle until a firm brake pedal is obtained by pumping the pedal until the pads are against the disc.

10-10 WHEELS/TIRES

Wheels (Rims)

Wheel Inspection

- Raise the front/rear wheel off the ground.

Special Tools - Jack: 57001-1238

Jack Attachment: 57001-1608

Attachment Jack: 57001-1252

- Spin the wheel lightly, and check for roughness or binding.
- ★ If roughness or binding is found, replace the hub bearings (see Hub Bearing Removal/Installation).
- Inspect the wheel for small cracks, dents, bending, or warp.
- ★ If there is any damage to the wheel, replace the wheel.
- Remove the wheel, and support it with the tire by the axle.
- Measure the rim runout, axial [A] and radial [B], with a dial gauge.
- ★ If rim runout exceeds the service limit, check the hub bearings (see Hub Bearing Inspection).
- ★ If the problem is not due to the bearings, replace the wheel.

Rim Runout (with tire installed)

Standard:

Axial TIR 0.5 mm (0.02 in.) or less

Radial TIR 0.8 mm (0.03 in.) or less

Service Limit:

Axial TIR 1.0 mm (0.04 in.)

Radial TIR 1.0 mm (0.04 in.)

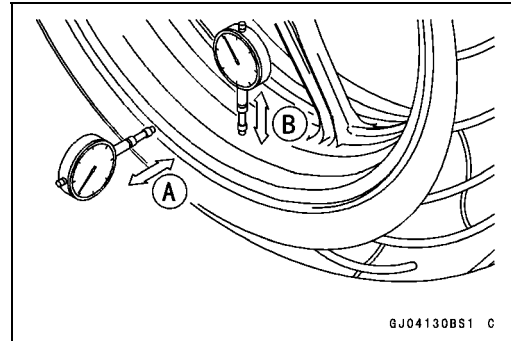

⚠ WARNING

Damaged wheel parts may fail and cause an accident resulting in serious injury or death. Never attempt to repair a damaged wheel part. If the wheel part is damaged, it must be replaced with a new one.

Axle Inspection

- Remove the front and rear axles (see Front/Rear Wheel Removal).
- Visually inspect the front and rear axle for damages.
- ★ If the axle is damaged or bent, replace it.
- Place the axle in V blocks that are 100 mm (3.94 in.) [A] apart, and set a dial gauge [B] on the axle at a point halfway between the blocks. Turn [C] the axle to measure the runout. The difference between the highest and lowest dial readings is the amount of runout.
- ★ If axle runout exceeds the service limit, replace the axle.

Axle Runout/100 mm (3.94 in.)

Standard: TIR 0.1 mm (0.004 in.) or less

Service Limit: TIR 0.2 mm (0.008 in.)

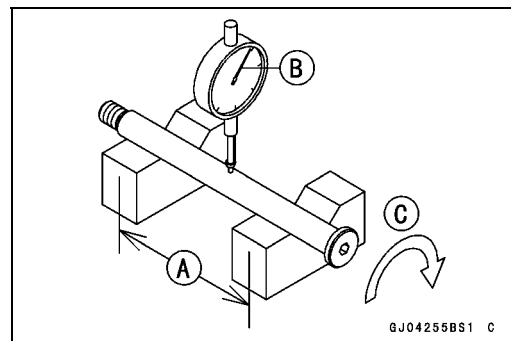

Wheels (Rims)

Balance Inspection

- Remove the front and rear wheels (see Front/Rear Wheel Removal).
- Support the wheel so that it can be spun freely.
- Spin the wheel lightly, and mark [A] the wheel at the top when the wheel stops.
- Repeat this procedure several times. If the wheel stops of its own accord in various positions, it is well balanced.
- ★ If the wheel always stops in one position, adjust the wheel balance (see Balance Adjustment).

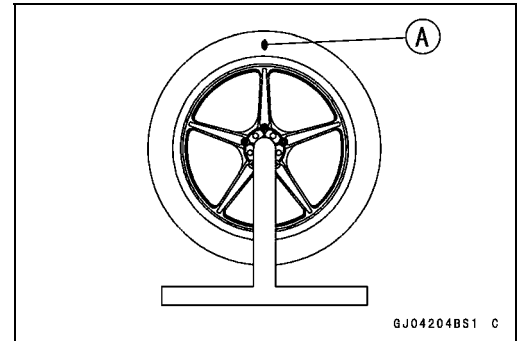

Balance Adjustment

- If the wheel always stops in one position, provisionally attach a balance weight [A] on the rim at the marking using adhesive tape.
- Rotate the wheel 1/4 turn [B], and see whether or not the wheel stops in this position. If it does, the correct balance weight is being used.
- ★ If the wheel rotates and the weight goes up, replace the weight with the next heavier size. If the wheel rotates and the weight goes down, replace the weight with the next lighter size. Repeat these steps until the wheel remains at rest after being rotated 1/4 turn.
- Rotate the wheel another 1/4 turn and then another 1/4 turn to see if the wheel is correctly balanced.
- Repeat the entire procedure as many times as necessary to achieve correct wheel balance.
- Permanently install the balance weight.

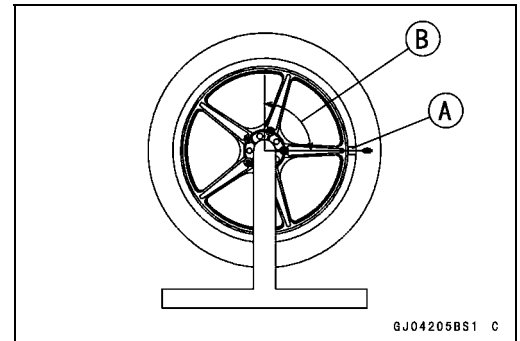

Balance Weight Removal

- Insert a standard tip screwdrivers [A] [B] between the rib [C] and weight [D] as shown in the figure.
- Pry the balance weight with two screwdrivers and remove the balance weight.
- Discard the used balance weight.

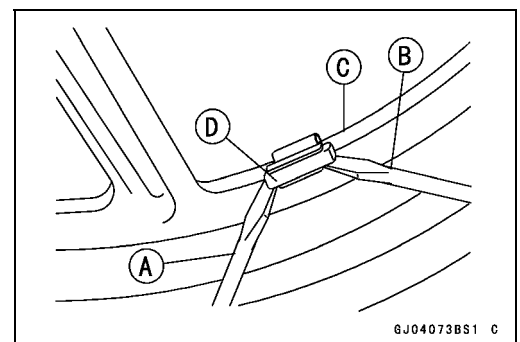

NOTICE

Do not tap the screwdrivers. The rim could be damaged.

Balance Weight Installation

- Check if the weight portion has any play on the blade [A] and clip [B].
- ★ If it does, discard it.

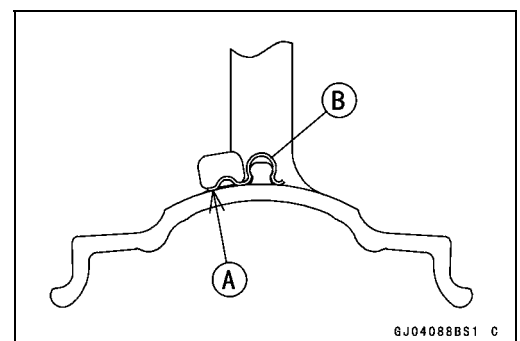

⚠ WARNING

Unbalanced wheels can create an unsafe riding condition. If the balance weight has any play on the rib of the rim, the blade and/or clip have been stretched. Replace the loose balance weight. Do not reuse used balance weight.

10-12 WHEELS/TIRES

Wheels (Rims)

Balance Weight

Part Number	Weight
41075-0007	10 g (0.35 oz.)
41075-0008	20 g (0.71 oz.)
41075-0009	30 g (1.06 oz.)

NOTE

- Balance weights are available from Kawasaki dealers in 10, 20 and 30 grams (0.35, 0.71 and 1.06 oz.) sizes. An imbalance of less than 10 grams (0.35 oz.) will not usually affect running stability.
- Do not use four or more balance weight (more than 90 gram, 3.2 oz.). If the wheel requires an excess balance weight, disassemble the wheel to find the cause.

- Slip the balance weight [A] onto the rib [B] by pushing or lightly hammering [C] the clip [D].

Left Side [E]
Right Side [F]

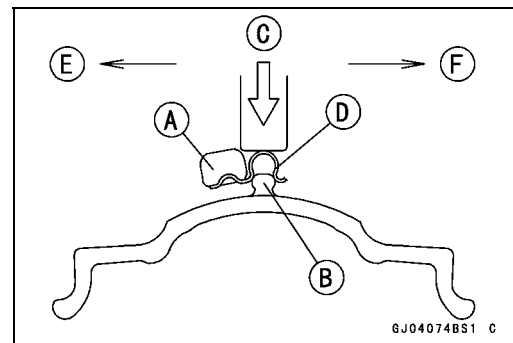

- Be sure to install the balance weight.
- Check that the blade [A] and clip [B] are fully seated on the rim [C] and that the clip is hooked over the rib [D].

Left Side [E]
Right Side [F]

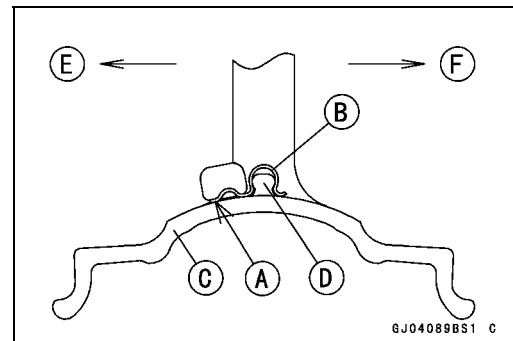

Tires

Air Pressure Inspection/Adjustment

- Refer to the Air Pressure Inspection in the Periodic Maintenance chapter.

Tire Inspection

- Refer to the Wheel/Tire Damage Inspection in the Periodic Maintenance chapter.

Tire Removal

- Remove:
 - Wheels (see Front/Rear Wheel Removal)
 - Valve Core (Let out the air)
- To maintain wheel balance, mark the valve stem position on the tire with chalk so that the tire can be reinstalled in the same position.
 - Chalk Mark or Yellow Mark [A]
 - Air Valve [B]
 - Align [C]
- Lubricate the tire beads and rim flanges on both sides with a soap and water solution or rubber lubricant. This helps the tire beads slip off the rim flanges.

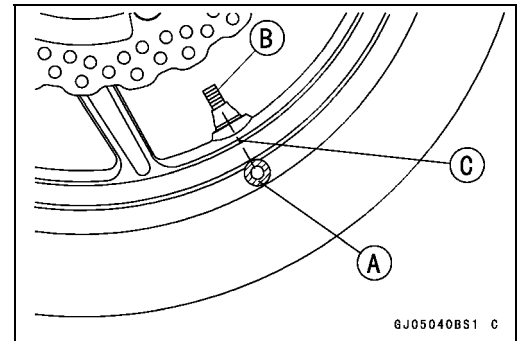

NOTICE

Never lubricate with engine oil or petroleum distillates because they will deteriorate the tire.

- Remove the tire from the rim using a suitable commercially available tire changer.

NOTE

○ *The tires cannot be removed with hand tools because they fit the rims too tightly.*

Tire Installation

WARNING

Some replacement tires may adversely affect handling and cause an accident resulting in serious injury or death. To ensure proper handling and stability, use only the recommended standard tires for replacement, inflated to the standard pressure.

- Inspect the rim and tire, and replace them if necessary.
- Clean the sealing surfaces of the rim and tire, and smooth the sealing surfaces of the rim with a fine emery cloth if necessary.
- Remove the air valve and discard it.

NOTICE

Replace the air valve whenever the tire is replaced. Do not reuse the air valve.

10-14 WHEELS/TIRES

Tires

- Install a new valve in the rim.
- Remove the valve cap, lubricate the stem seal [A] with a soap and water solution or rubber lubricant, and pull [B] the valve stem through the rim from the inside out until it snaps into place.

NOTICE

Do not use engine oil or petroleum distillates to lubricate the stem because they will deteriorate the rubber.

- The air valve is shown in the figure.

Valve Cap [A]
Valve Core [B]
Stem Seal [C]
Valve Stem [D]
Valve Seat [E]
Valve Opened [F]

- Check the tire rotation mark on the front and rear tires and install them on the rim accordingly.

Tire Rotation Mark [A]
Rotating Direction [B]

- Position the tire on the rim so that the valve [A] align with the tire balance mark [B] (the chalk mark made during removal, or the yellow paint mark on a new tire).
- Install the tire bead over the rim flange using a suitable commercially available tire changer.
- Lubricate the tire beads and rim flanges with a soap and water solution or rubber lubricant to help seat the tire beads in the sealing surfaces of the rim while inflating the tire.
- Center the rim in the tire beads, and inflate the tire with compressed air until the tire beads seat in the sealing surfaces.

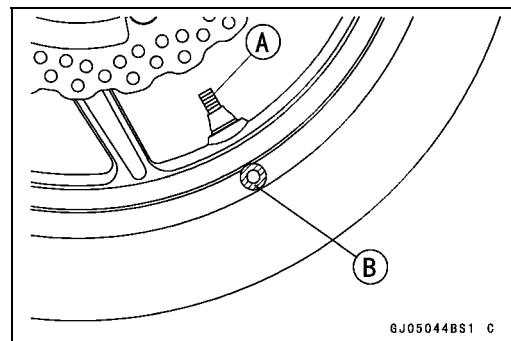
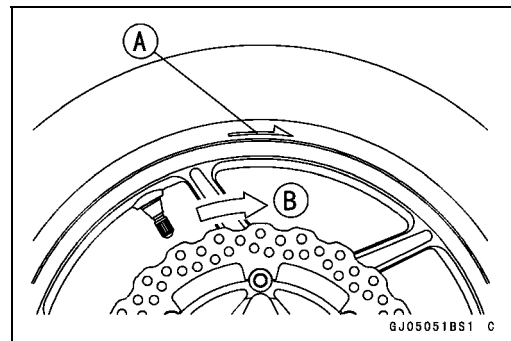
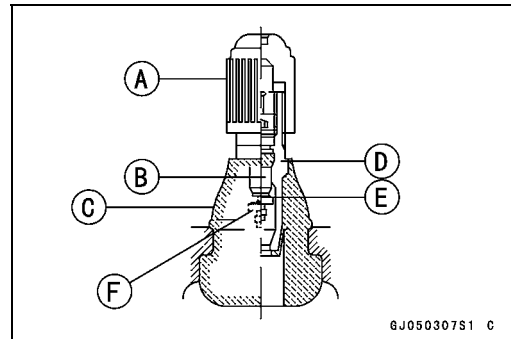
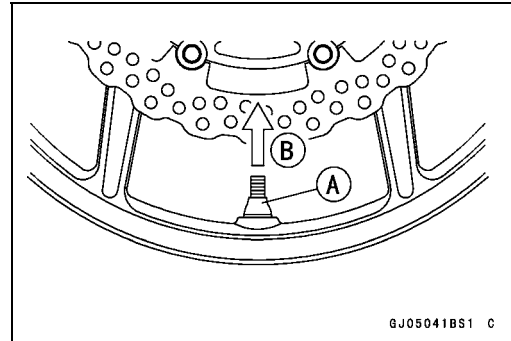

WARNING

Overinflating a tire can cause it to explode, causing serious injury or death. Be sure to install the valve core whenever inflating the tire, and do not inflate the tire to more than 400 kPa (4.0 kgf/cm², 57 psi).

Tires

- Check to see that the rim lines [A] on both sides of the tire sidewalls are parallel with the rim flanges.
- ★ If the rim flanges and tire sidewall rim lines are not parallel, remove the valve core.
- Lubricate the rim flanges and tire beads.
- Install the valve core and inflate the tire again.
- After the tire beads seat in the rim flanges, check for air leakage.
- Inflate the tire slightly above standard inflation.
- Use a soap and water solution or submerge the tire, and check for bubbles that would indicate leakage.
- Adjust the air pressure to the specified pressure (see Air Pressure Inspection in the Periodic Maintenance chapter).
- Install the air valve cap.
- Adjust the wheel balance (see Balance Adjustment).

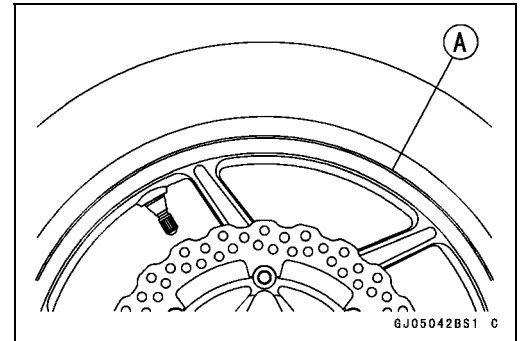

Tire Repair

Currently two types of repair for tubeless tires have come into wide use. One type is called a temporary (external) repair which can be carried out without removing the tire from the rim, and the other type is called permanent (internal) repair which requires tire removal. It is generally understood that higher running durability is obtained by permanent (internal) repairs than by temporary (external) ones. Also, permanent (internal) repairs have the advantage of permitting a thorough examination for secondary damage not visible from external inspection of the tire. For these reasons, Kawasaki does not recommend temporary (external) repair. Only appropriate permanent (internal) repairs are recommended. Repair methods may vary slightly from make to make. Follow the repair methods indicated by the manufacturer of the repair tools and materials so that safe results can be obtained.

10-16 WHEELS/TIRES

Hub Bearing

Hub Bearing Removal

- Remove the wheels (see Front/Rear Wheel Removal), and take out the following.

Collars [A]
Coupling [B] (Out of rear hub)
Grease Seals [C]
Circlip [D]

Special Tool - Inside Circlip Pliers: 57001-143

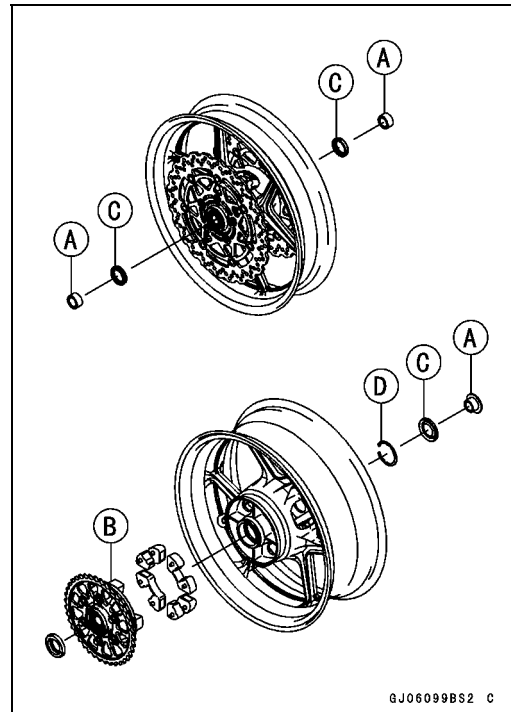

- Use the bearing remover to remove the hub bearings [A].

NOTICE

Do not lay the wheel on the ground with the disc facing down. This can damage or warp the disc. Place blocks under the wheel so that the disc does not touch the ground.

Special Tools - Bearing Remover Head, $\phi 20 \times \phi 22$ [B]:
57001-1293

Bearing Remover Shaft, $\phi 13$ [C]: 57001-1377

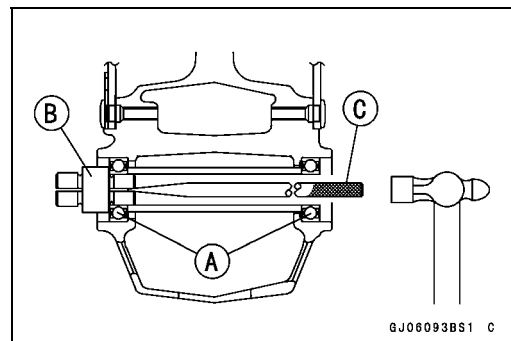

Hub Bearing Installation

- Before installing the hub bearings, blow any dirt or foreign particles out of the hub with compressed air to prevent contamination of the bearings.
- Replace the bearings with new ones.
- Install the bearings by using the bearing driver set which does not contact the bearing inner race.

NOTE

○ Install the bearings so that the marked side faces out.

- Press in each right the bearing [A] until they are bottomed.

Special Tool - Bearing Driver Set [B]: 57001-1129

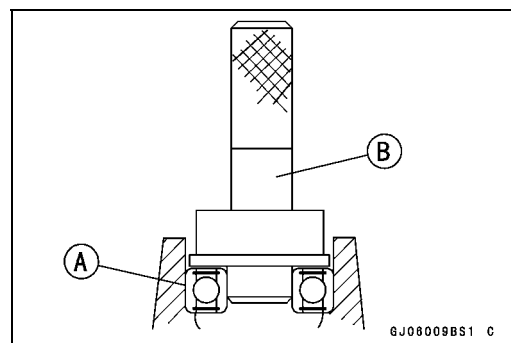

Hub Bearing

- Replace the circlip with a new one.
Special Tool - Inside Circlip Pliers: 57001-143
- Replace the grease seals with new ones.
- Press in the grease seals [A] so that the seal surface flush [B] with the end of the hole.
- Apply high-temperature grease to the grease seal lips.
Special Tool - Bearing Driver Set [C]: 57001-1129

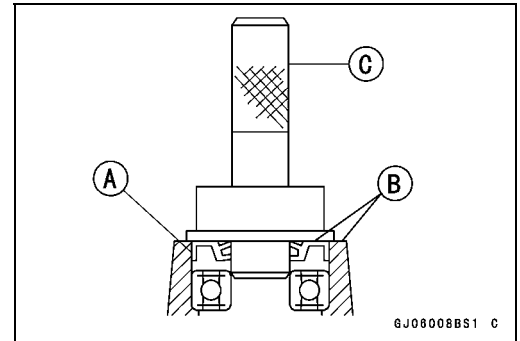

Hub Bearing Inspection

Since the hub bearings are made to extremely close tolerances, the clearance can not normally be measured.

NOTE

- Do not remove any bearings for inspection. If any bearings are removed, they will need to be replaced with new ones.
- Turn each bearing in the hub back and forth [A] while checking for plays, roughness, or binding.
- ★ If bearing play, roughness, or binding is found, replace the bearing.
- Examine the bearing seal [B] for tears or leakage.
- ★ If the seal is torn or is leaking, replace the bearing.

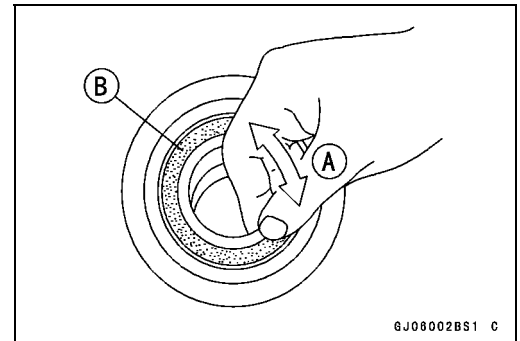

Hub Bearing Lubrication

NOTE

- Since the hub bearings are packed with grease and sealed, lubrication is not required.

Final Drive

Table of Contents

Exploded View.....	11-2
Specifications	11-4
Special Tools	11-5
Drive Chain.....	11-6
Drive Chain Slack Inspection.....	11-6
Drive Chain Slack Adjustment	11-6
Wheel Alignment Inspection/Adjustment	11-6
Drive Chain Wear Inspection	11-6
Drive Chain Lubrication.....	11-6
Drive Chain Removal	11-6
Drive Chain Installation	11-7
Drive Chain Replacement.....	11-7
Sprocket, Coupling	11-11
Engine Sprocket Cover Removal.....	11-11
Engine Sprocket Cover Installation.....	11-11
Engine Sprocket Removal	11-12
Engine Sprocket Installation	11-12
Rear Sprocket Removal.....	11-12
Rear Sprocket Installation.....	11-13
Coupling Installation.....	11-13
Coupling Bearing Removal	11-13
Coupling Bearing Installation	11-14
Coupling Bearing Inspection.....	11-14
Coupling Bearing Lubrication.....	11-14
Coupling Damper Inspection.....	11-14
Sprocket Wear Inspection.....	11-15
Rear Sprocket Warp Inspection	11-15

11-2 FINAL DRIVE

Exploded View

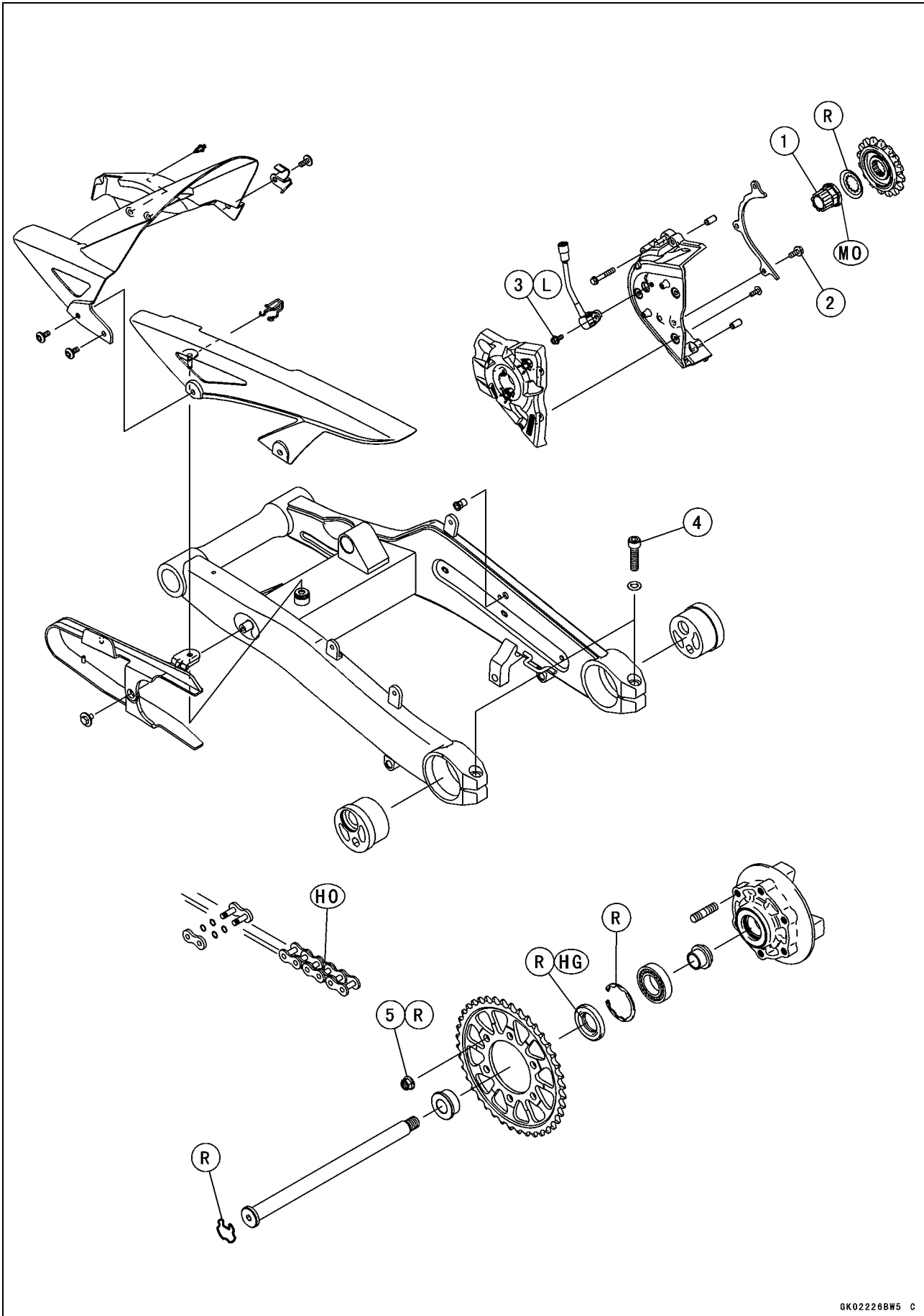

Exploded View

No.	Fastener	Torque			Remarks
		N·m	kgf·m	ft·lb	
1	Engine Sprocket Nut	125	12.7	92.2	MO
2	Drive Chain Guide Bolts	9.8	1.0	87 in·lb	
3	Speed Sensor Mounting Bolt	6.9	0.70	61 in·lb	L
4	Chain Adjuster Clamp Bolts	64	6.5	47	
5	Rear Sprocket Nuts	59	6.0	44	

HG: Apply high-temperature grease.

HO: Apply heavy oil.

MO: Apply molybdenum disulfide oil.

(mixture of the engine oil and molybdenum disulfide grease in a weight ratio 10 : 1)

R: Replacement Parts

11-4 FINAL DRIVE

Specifications

Item	Standard	Service Limit
Drive Chain		
Drive Chain Slack	20 ~ 30 mm (0.8 ~ 1.2 in.)	---
Drive Chain Wear (20-link Length)	317.5 ~ 318.2 mm (12.50 ~ 12.53 in.)	319 mm (12.56 in.)
Standard Chain:		
Make	ENUMA	---
Type	EK525ZX	---
Link	112 links	---
Link Pin Outside Diameter (When drive chain replacing)	5.6 ~ 6.0 mm (0.22 ~ 0.24 in.)	---
Link Plates Outside width (When drive chain replacing)	20.35 ~ 20.55 mm (0.8012 ~ 0.8091 in.)	---
Sprockets		
Rear Sprocket Warp	0.4 mm (0.016 in.) or less	0.5 mm (0.020 in.)

Special Tools

Inside Circlip Pliers:
57001-143

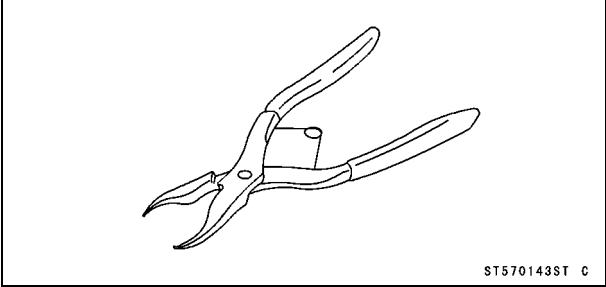

Bearing Driver Set:
57001-1129

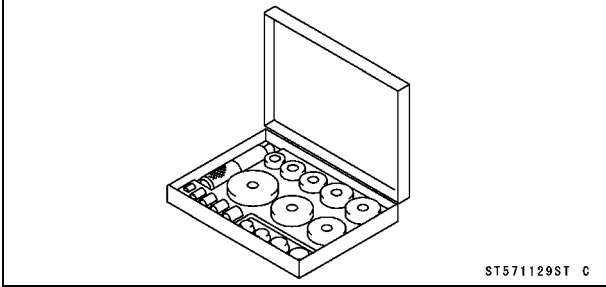

11-6 FINAL DRIVE

Drive Chain

Drive Chain Slack Inspection

- Refer to the Drive Chain Slack Inspection in the Periodic Maintenance chapter.

Drive Chain Slack Adjustment

- Refer to the Drive Chain Slack Adjustment in the Periodic Maintenance chapter.

Wheel Alignment Inspection/Adjustment

- Refer to the Wheel Alignment Inspection in the Periodic Maintenance chapter.

Drive Chain Wear Inspection

- Refer to the Drive Chain Wear Inspection in the Periodic Maintenance chapter.

Drive Chain Lubrication

- Refer to the Drive Chain Lubrication Condition Inspection in the Periodic Maintenance chapter.

Drive Chain Removal

- Remove:
 - Mud Guard (see Mud Guard Removal in the Frame chapter)
 - Rear Wheel (see Rear Wheel Removal in the Wheels/Tires chapter)
 - Chain Cover Bolt [A]

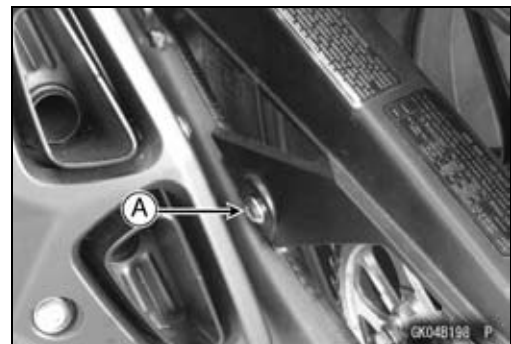

- Remove:
 - Clamp [A]
 - Chain Cover [B]
 - Swingarm (see Swingarm Removal in the Suspension chapter)

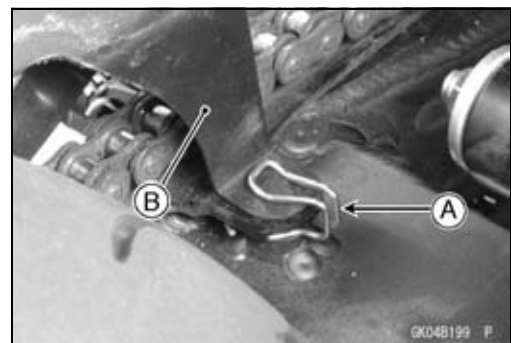

- Remove:
 - Engine Sprocket Cover (see Engine Sprocket Cover)
- Remove the drive chain [A] from the engine sprocket [B], and take it off the chassis.

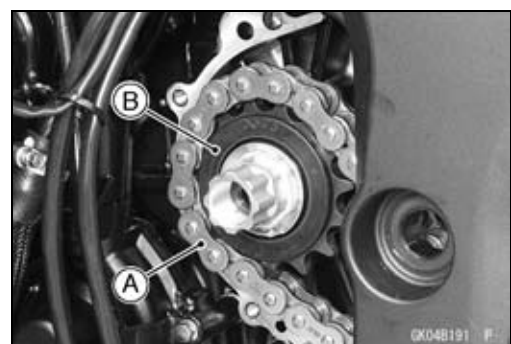

Drive Chain

Drive Chain Installation

- Install the drive chain to the engine sprocket.
- Install:
 - Swingarm (see Swingarm Installation in the Suspension chapter)
 - Rear Wheel (see Rear Wheel Installation in the Wheels/Tires chapter)
 - Engine Sprocket Cover (see Engine Sprocket Cover Installation)
- Insert the projection [A] on the chain cover into the swingarm hole [B].
- Adjust the drive chain slack after installing the chain (see Drive Chain Slack Adjustment in the Periodic Maintenance chapter).

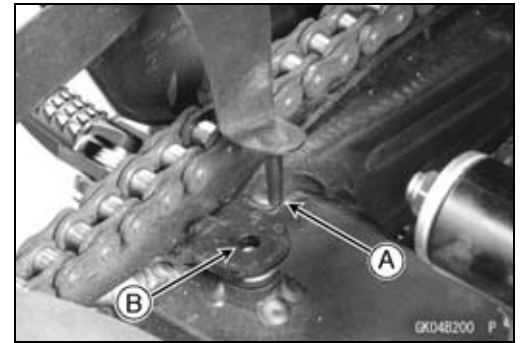

Drive Chain Replacement

- Remove:
 - Chain Cover (see Drive Chain Removal)
 - Engine Sprocket Cover (see Engine Sprocket Removal)

NOTICE

For safety, if the drive chain shall be replaced, replace it using a recommended tool.

**Recommended Tool - Type: EK Joint Tool #50
Brand: ENUMA**

Body [A]
 Handlebar [B]
 Cutting and Riveting Pin [C]
 For Cutting [D]
 For Riveting [E]
 Plate Holder (A) [F]
 Plate Holder (B) [G]
 Gauge [H]

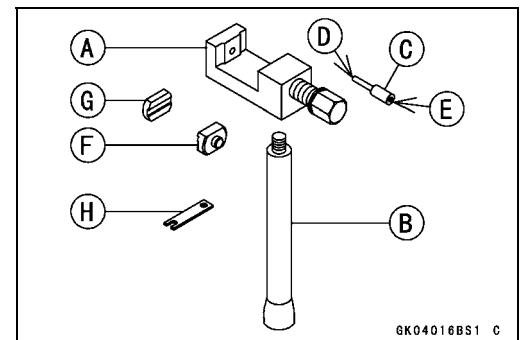

- Grind [A] the pin head to make it flat.
- Set the cutting and riveting pin [B] as shown in the figure.

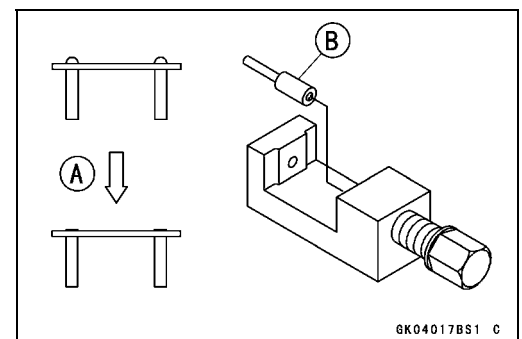

11-8 FINAL DRIVE

Drive Chain

- Screw the pin holder until it touches chain pin.
- Be sure that the cutting pin hits center of chain pin.

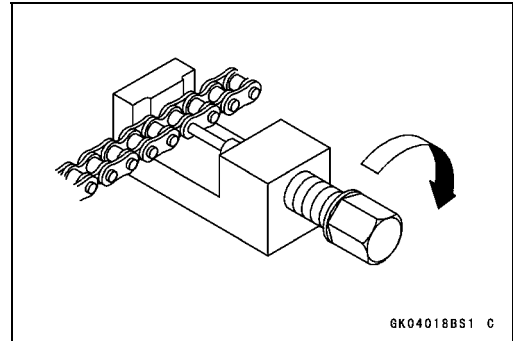

- Screw the handlebar [A] into body.
- Turn the pin holder with wrench [B] clockwise to extract chain pin.

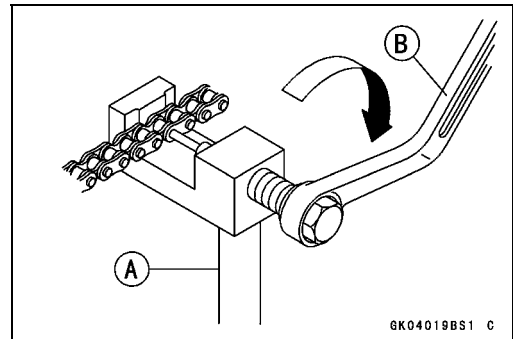

- Replace the link pin, link plate and grease seals.
- Apply grease to the link pins [A] and grease seals [B] [C].
- Engage the drive chain on the engine and rear sprockets.
- Insert the link pins in the drive chain ends.
- Install the grease seals.
- Install the link plate [D] so that the mark faces out.
- Push the link plate by hand or plier to fix it.
- In case of grease seals chain, be sure to set the grease seals correctly.

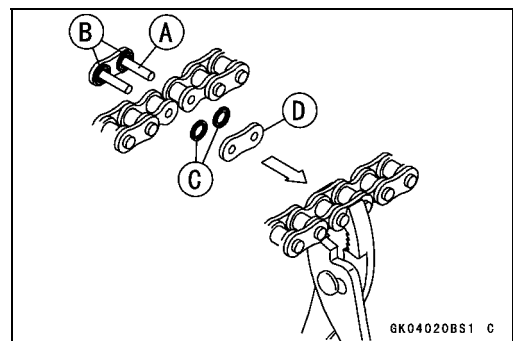

- Set the plate holder (A) [A] and plate holder (B) [B] on the body.

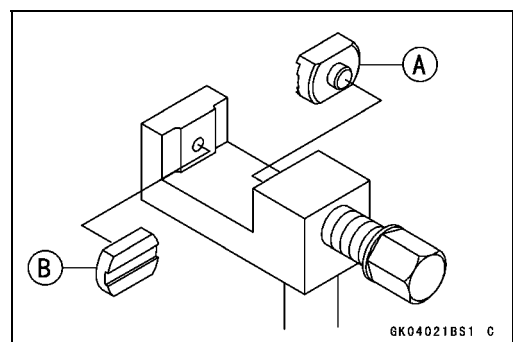

- Fit the plate holder (A) [A] to link plate.
- Turn the pin holder by hand until plate holder (B) [B] touches the other link plate.

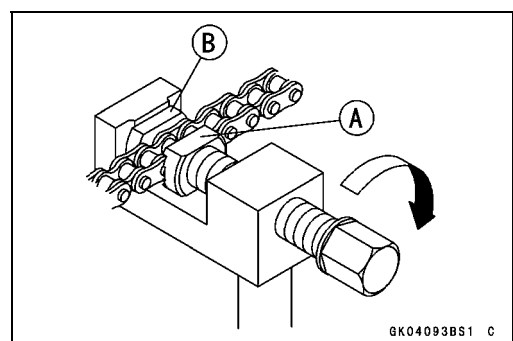

Drive Chain

- Turn the pin holder [A] by wrench clockwise until two pins of link come into groove of plate holders [B].
- Take off the plate holder.

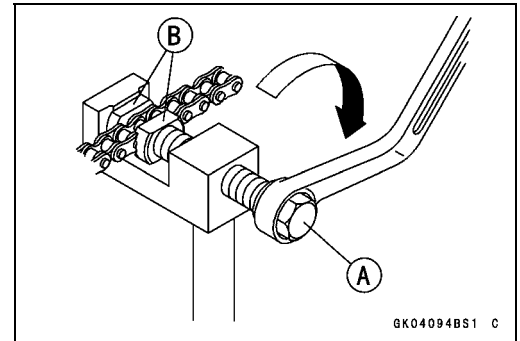

- Set the plate holder (B) [A] and cutting and riveting pin [B] as shown in the figure.

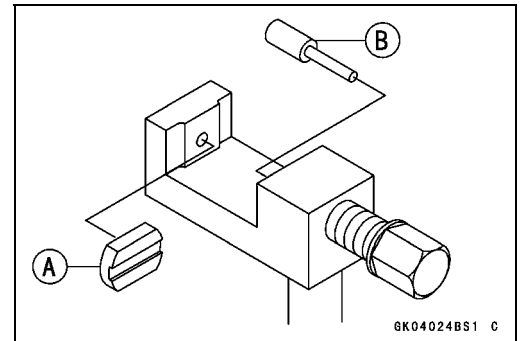

- Turn the pin holder until riveting pin touches link pin.

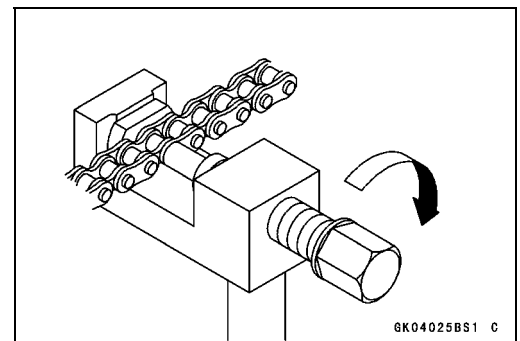

- Turn the wrench clockwise until tip of riveting pin hits to the link pin.
- Rivet it.
- Same work for the other link pin.

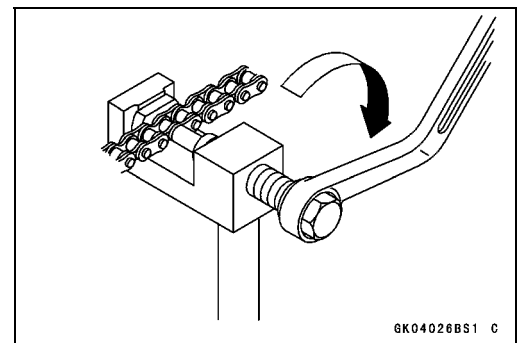

11-10 FINAL DRIVE

Drive Chain

- After staking, check the staked area of the link pin for cracks.
- Measure the outside diameter [A] of the link pin and link plates width [B].

Link Pin Outside Diameter

Standard: 5.6 ~ 6.0 mm (0.22 ~ 0.24 in.)

Link Plates Outside Width

Standard: 20.35 ~ 20.55 mm (0.8012 ~ 0.8091 in.)

- ★ If the reading exceeds the specified length, cut and rejoin the chain again.

- Check:

Movement of the Rollers

- Adjust the drive chain slack after installing the chain (see Drive Chain Slack Adjustment in the Periodic Maintenance chapter).

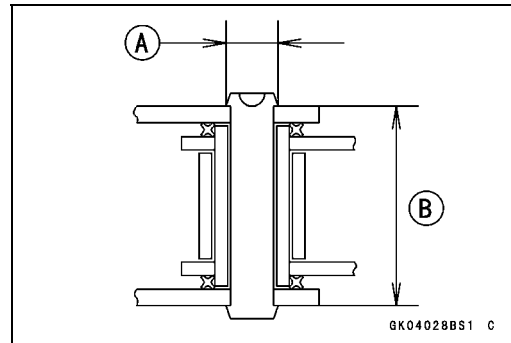

Sprocket, Coupling

Engine Sprocket Cover Removal

- Remove:
 - Right Lower Fairing (see Lower Fairing Removal in the Frame chapter)
 - Engine Sprocket Inner Cover Bolts [A]
 - Engine Sprocket Inner and Outer Cover [B]

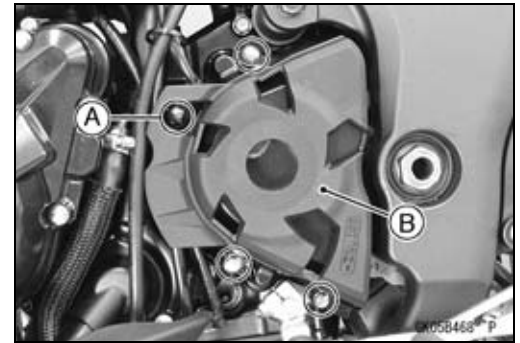

- Remove the engine sprocket outer cover screws [A] to separate the outer and inner cover [B].

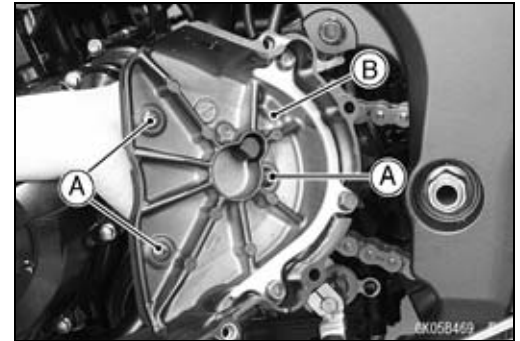

- Remove the speed sensor bolt [A].



Engine Sprocket Cover Installation

- Be sure to install the drive chain guide [A].
- Tighten:
 - Torque - Drive Chain Guide Bolts [B]: 9.8 N-m (1.0 kgf-m, 87 in-lb)**

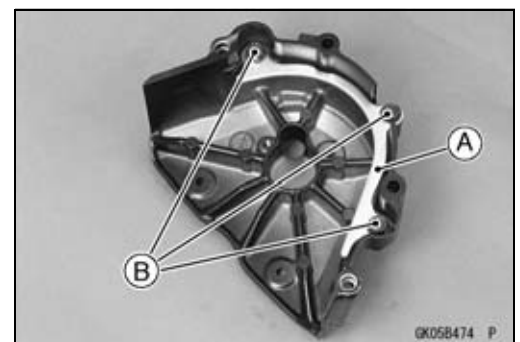

- Apply a non-permanent locking agent to the thread of the speed sensor mounting bolt.
- Tighten:
 - Torque - Speed Sensor Mounting Bolt: 6.9 N-m (0.70 kgf-m, 61 in-lb)**

- Install the engine sprocket outer cover to the inner cover.
- Be sure to install the dowel pins [A].
- Install the engine sprocket inner cover.



11-12 FINAL DRIVE

Sprocket, Coupling

Engine Sprocket Removal

- Remove:
 - Left Lower Fairing (see Lower Fairing Removal in the Frame chapter)
 - Engine Sprocket Cover (see Engine Sprocket Cover Removal)
- Flatten out the bended washer [A].
- Remove the engine sprocket nut [B] and washer.

NOTE

○ When loosening the engine sprocket nut, hold the rear brake on.

- Raise the rear wheel off the ground with the stand.
- Loosen the drive chain (see Drive Chain Slack Adjustment in the Periodic Maintenance chapter).
- Remove the drive chain from the rear sprocket toward the right.
- Disengage the drive chain [A] from the engine sprocket [B].
- Pull the engine sprocket off the output shaft [C].

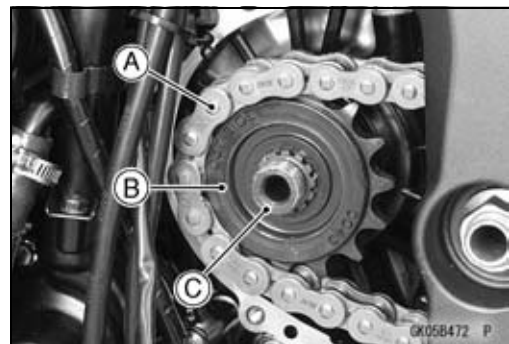
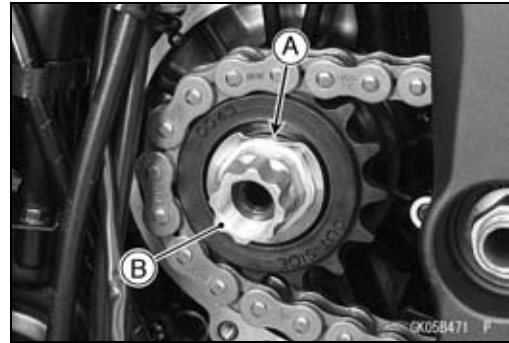

Engine Sprocket Installation

- Replace the sprocket washer.
- Install the engine sprocket so that "OUT SIDE" letters [A] face outward.
- Apply molybdenum disulfide oil solution to the threads and the seating surface of the engine sprocket nut.
- Tighten:

Torque - Engine Sprocket Nut: 125 N·m (12.7 kgf·m, 92.2 ft·lb)

NOTE

○ Tighten the nut while applying the rear brake.

- After torquing the engine sprocket nut, bend the one side of the washer over the nut.
- Adjust the drive chain slack after installing the engine sprocket (see Drive Chain Slack Adjustment in the Periodic Maintenance chapter).



Rear Sprocket Removal

- Remove the rear wheel (see Rear Wheel Removal in the Wheels/Tires chapter).

NOTICE

Do not lay the wheel on the ground with the disc facing down. This can damage or warp the disc. Place blocks under the wheel so that the disc does not touch the ground.

- Remove the rear sprocket nuts [A].
- Remove the rear sprocket [B].

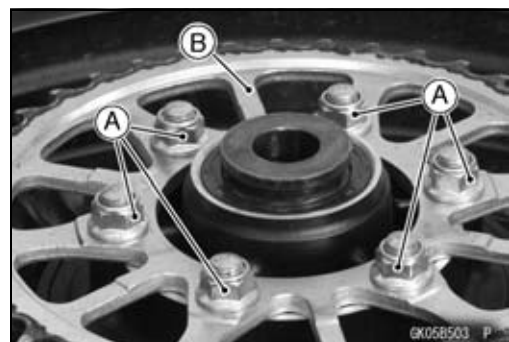

Sprocket, Coupling

Rear Sprocket Installation

- Install the sprocket facing the tooth number marking [A] outward.
- Replace the rear sprocket nuts with new ones.
- Tighten:
Torque - Rear Sprocket Nuts: 59 N·m (6.0 kgf·m, 44 ft·lb)
- Install the rear wheel (see Rear Wheel Installation in the Wheels/Tires chapter).

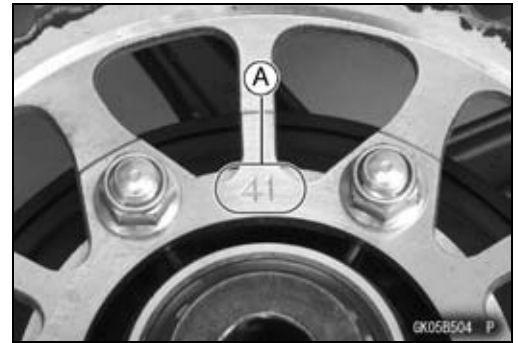

Coupling Installation

- Apply high-temperature grease to the following parts.
 Coupling Grease Seal Lip [A]
 Coupling Internal Surface [B]

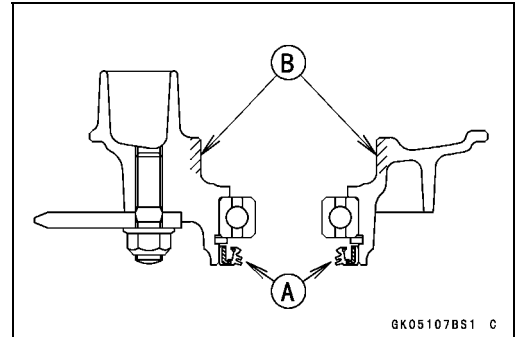

- Install:
 Collar [A]
 Coupling [B]

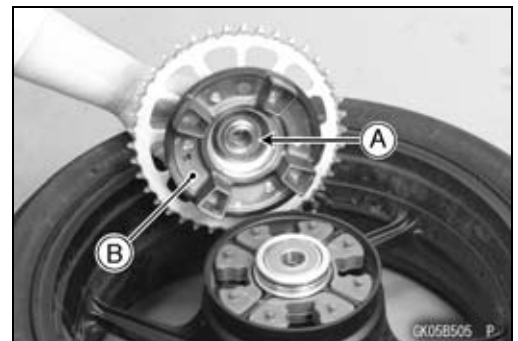

Coupling Bearing Removal

- Remove:
 Coupling
 Grease Seal
 Circlip [A]
- **Special Tool - Inside Circlip Pliers: 57001-143**

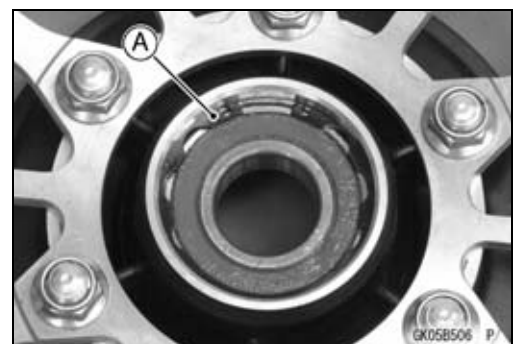

- Remove the bearing [A] by tapping from the wheel side.
Special Tool - Bearing Driver Set [B]: 57001-1129

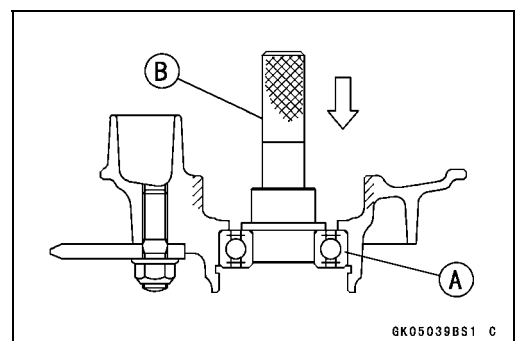

11-14 FINAL DRIVE

Sprocket, Coupling

Coupling Bearing Installation

- Replace the bearing with a new one.
- Press in the bearing [A] until it is bottomed.

Special Tool - Bearing Driver Set [B]: 57001-1129

- Pack the bearing with high-temperature grease.
- Replace the circlip with a new one.

Special Tool - Inside Circlip Pliers: 57001-143

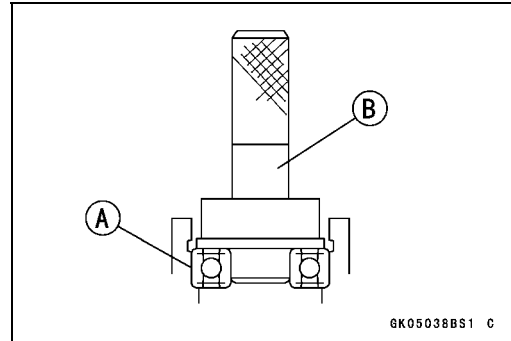

- Replace the grease seal with a new one.
- Press in the grease seal so that the seal surface is flush with the end of the hole.
- Apply high-temperature grease to the grease seal lip.

Special Tool - Bearing Driver Set: 57001-1129

Coupling Bearing Inspection

Since the coupling bearing is made to extremely close tolerances, the clearance can not normally be measured.

NOTE

○ *It is not necessary to remove the coupling bearing for inspection. If the bearing is removed, it will need to be replaced with a new one.*

- Turn the bearing in the coupling back and forth [A] while checking for plays, roughness or binding.
- ★ If the bearing play, roughness or binding is found, replace the bearing.
- Examine the bearing seal [B] for tears or leakage.
- ★ If the seal is torn or is leaking, replace the bearing.

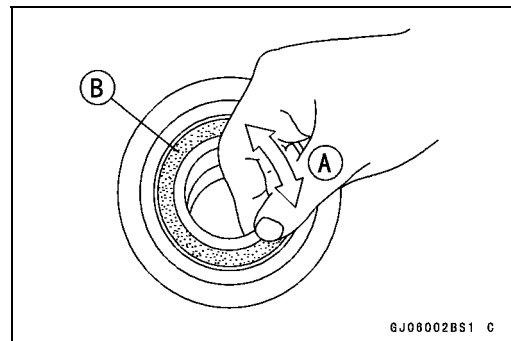

Coupling Bearing Lubrication

NOTE

○ *Since the coupling bearing is packed with grease and sealed, lubrication is not required.*

Coupling Damper Inspection

- Remove the rear wheel coupling, and inspect the rubber dampers [A].
- Replace the damper if it appears damaged or deteriorated.



Sprocket, Coupling

Sprocket Wear Inspection

- Visually inspect the engine and rear sprocket teeth for wear and damage.
- ★ If the teeth are worn as illustrated, replace the sprocket, and inspect the drive chain wear (see Drive Chain Wear Inspection in the Periodic Maintenance chapter).
 - Worn Tooth (Engine Sprocket) [A]
 - Worn Tooth (Rear Sprocket) [B]
 - Direction of Rotation [C]

NOTE

- If a sprocket requires replacement, the chain is probably worn also. When replacing a sprocket, inspect the chain.

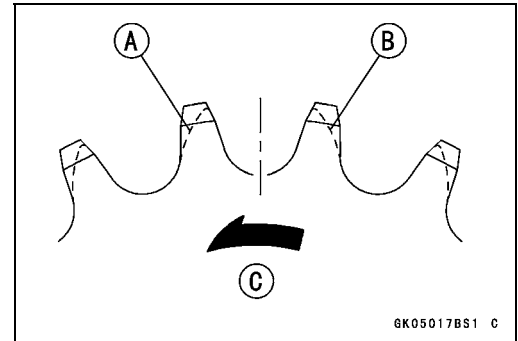

Rear Sprocket Warp Inspection

- Raise the rear wheel off the ground with the stand so that it will turn freely.
- Set a dial gauge [A] against the rear sprocket [B] near the teeth as shown in the figure, and rotate [C] the rear wheel to measure the sprocket runout (warp). The difference between the highest and lowest dial gauge readings is the amount of runout (warp).
- ★ If the runout exceeds the service limit, replace the rear sprocket.

Rear Sprocket Warp

Standard: 0.4 mm (0.016 in.) or less

Service Limit: 0.5 mm (0.020 in.)

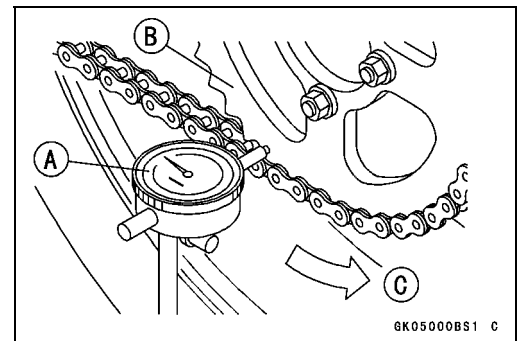

Brakes

Table of Contents

Exploded View.....	12-3
Specifications	12-10
Special Tools	12-11
Brake Lever, Brake Pedal.....	12-12
Brake Lever Position Adjustment.....	12-12
Brake Pedal Position Inspection	12-12
Brake Pedal Position Adjustment.....	12-12
Brake Pedal Removal	12-12
Brake Pedal Installation	12-13
Calipers	12-14
Front Caliper Removal	12-14
Rear Caliper Removal.....	12-14
Caliper Installation	12-15
Front Caliper Disassembly.....	12-15
Front Caliper Assembly.....	12-15
Rear Caliper Disassembly	12-15
Rear Caliper Assembly	12-15
Caliper Fluid Seal Damage.....	12-16
Rear Caliper Dust Boot and Friction Boot Damage	12-16
Caliper Piston and Cylinder Damage.....	12-16
Rear Caliper Holder Shaft Wear	12-17
Brake Pads.....	12-18
Front Brake Pad Removal.....	12-18
Front Brake Pad Installation.....	12-18
Rear Brake Pad Removal	12-19
Rear Brake Pad Installation	12-19
Brake Pad Wear Inspection	12-19
Master Cylinder	12-20
Front Master Cylinder Removal	12-20
Front Master Cylinder Installation	12-20
Rear Master Cylinder Removal.....	12-20
Rear Master Cylinder Installation.....	12-21
Front Master Cylinder Disassembly	12-21
Rear Master Cylinder Disassembly.....	12-21
Master Cylinder Assembly	12-21
Master Cylinder Inspection (Visual Inspection).....	12-22
Brake Disc	12-23
Brake Disc Removal	12-23
Brake Disc Installation	12-23
Brake Disc Wear	12-23
Brake Disc Warp	12-23
Brake Fluid	12-24
Brake Fluid Level Inspection.....	12-24
Brake Fluid Change	12-24
Brake Line Bleeding.....	12-24
Brake Hose.....	12-28
Brake Hose Removal/Installation.....	12-28
Brake Hose and Pipe Inspection.....	12-28
Anti-Lock Brake System (Equipped Models).....	12-29
Parts Location	12-29

12-2 BRAKES

ABS Servicing Precautions	12-33
ABS Troubleshooting Outline.....	12-35
Inquiries to Rider.....	12-38
Self-diagnosis Outline	12-40
Self-diagnosis Procedures	12-40
Service Code Clearing Procedures.....	12-41
How to Read Service Codes.....	12-44
How to Erase Service Codes	12-44
ABS Indicator Light (LED) Inspection	12-46
Solenoid Coil Temperature Abnormal [High-Temperature] (Service Code 11).....	12-46
Solenoid Valve Inspection (Service Code 13, 14, 17, 18).....	12-46
ABS Solenoid Valve Relay Inspection (Service Code 19)	12-47
Front, Rear Wheel Rotation Difference Abnormal (Service Code 25)	12-47
ABS Motor Relay Inspection (Service Code 35).....	12-48
Front Wheel Rotation Sensor Signal Abnormal (Service Code 42)	12-48
Front Wheel Rotation Sensor Wiring Inspection (Service Code 43)	12-49
Rear Wheel Rotation Sensor Signal Abnormal (Service Code 44).....	12-50
Rear Wheel Rotation Sensor Wiring Inspection (Service Code 45).....	12-50
Power Supply Voltage Abnormal (Low-Voltage) (Service Code 52)	12-51
Power Supply Voltage Abnormal (Over-Voltage) (Service Code 53)	12-51
ECU Inspection (Service Code 55)	12-52
Wheel Rotation Sensor Signal Abnormal [Too High Speed] (Service Code 93)	12-52
ABS Hydraulic Unit Removal	12-52
ABS Hydraulic Unit Installation	12-54
ABS Hydraulic Unit Inspection	12-54
Front Wheel Rotation Sensor Removal	12-55
Front Wheel Rotation Sensor Installation	12-55
Rear Wheel Rotation Sensor Removal	12-56
Rear Wheel Rotation Sensor Installation	12-56
Wheel Rotation Sensor Inspection.....	12-57
Wheel Rotation Sensor Air Gap Inspection	12-57
Wheel Rotation Sensor Rotor Inspection.....	12-58
ABS Solenoid Valve Relay Fuse (20 A) Removal.....	12-58
ABS Motor Relay Fuse (30 A) Removal	12-58
ABS ECU Fuse (10 A) Removal	12-58
Fuse Installation.....	12-59
Fuse Inspection.....	12-59

Exploded View

This page intentionally left blank.

12-4 BRAKES

Exploded View

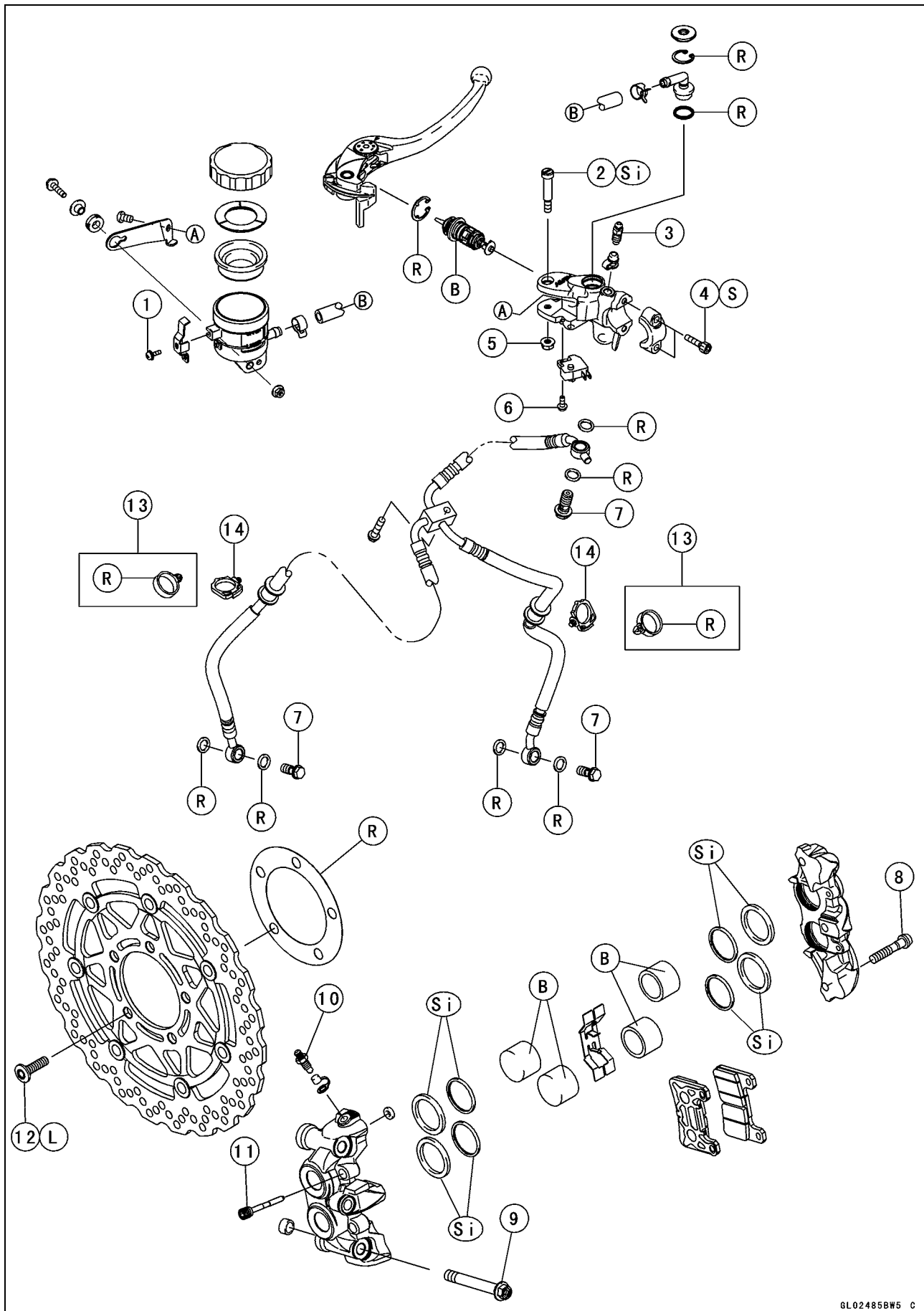

Exploded View

No.	Fastener	Torque			Remarks
		N·m	kgf·m	ft·lb	
1	Front Master Cylinder Reservoir Cap Stopper Screw	1.2	0.12	11 in·lb	
2	Brake Lever Pivot Bolt	1.0	0.10	8.8 in·lb	Si
3	Front Master Cylinder Bleed Valve	5.4	0.55	48 in·lb	
4	Front Master Cylinder Clamp Bolts	11	1.1	97 in·lb	S
5	Brake Lever Pivot Bolt Locknut	5.9	0.60	52 in·lb	
6	Front Brake Light Switch Screw	1.2	0.12	11 in·lb	
7	Brake Hose Banjo Bolts	25	2.5	18	
8	Front Caliper Assembly Bolts	22	2.2	16	
9	Front Caliper Mounting Bolts	34	3.5	25	
10	Bleed Valves	7.8	0.80	69 in·lb	
11	Front Brake Pad Pins	15	1.5	11	
12	Front Brake Disc Mounting Bolts	27	2.8	20	L

13. ZX1000GB Early Model

14. Face the lock portion of the clamp backward.

B: Apply brake fluid.

L: Apply a non-permanent locking agent.

R: Replacement Parts

S: Follow the specified tightening sequence.

Si: Apply silicone grease (ex. PBC grease).

12-6 BRAKES

Exploded View

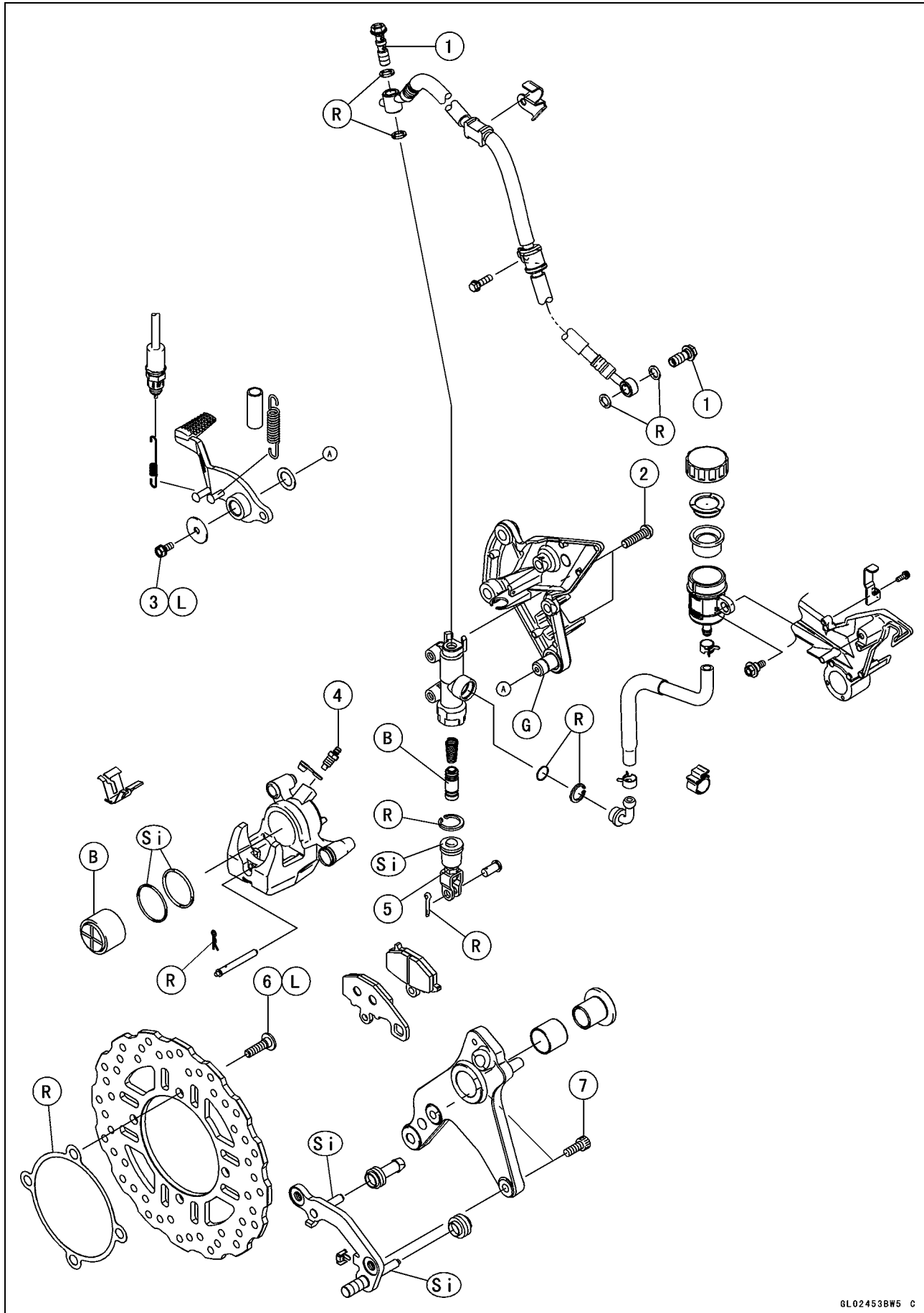

Exploded View

No.	Fastener	Torque			Remarks
		N·m	kgf·m	ft·lb	
1	Brake Hose Banjo Bolts	25	2.5	18	
2	Rear Master Cylinder Mounting Bolts	25	2.5	18	
3	Brake Pedal Bolt	8.8	0.90	78 in·lb	L
4	Bleed Valve	7.8	0.8	69 in·lb	
5	Rear Master Cylinder Push Rod Locknut	17	1.7	12	
6	Rear Brake Disc Mounting Bolts	27	2.8	20	L
7	Rear Caliper Mounting Bolts	25	2.5	18	

B: Apply brake fluid.

G: Apply grease.

L: Apply a non-permanent locking agent.

R: Replacement Parts

Si: Apply silicone grease (ex. PBC grease).

12-8 BRAKES

Exploded View

ABS Equipped Models

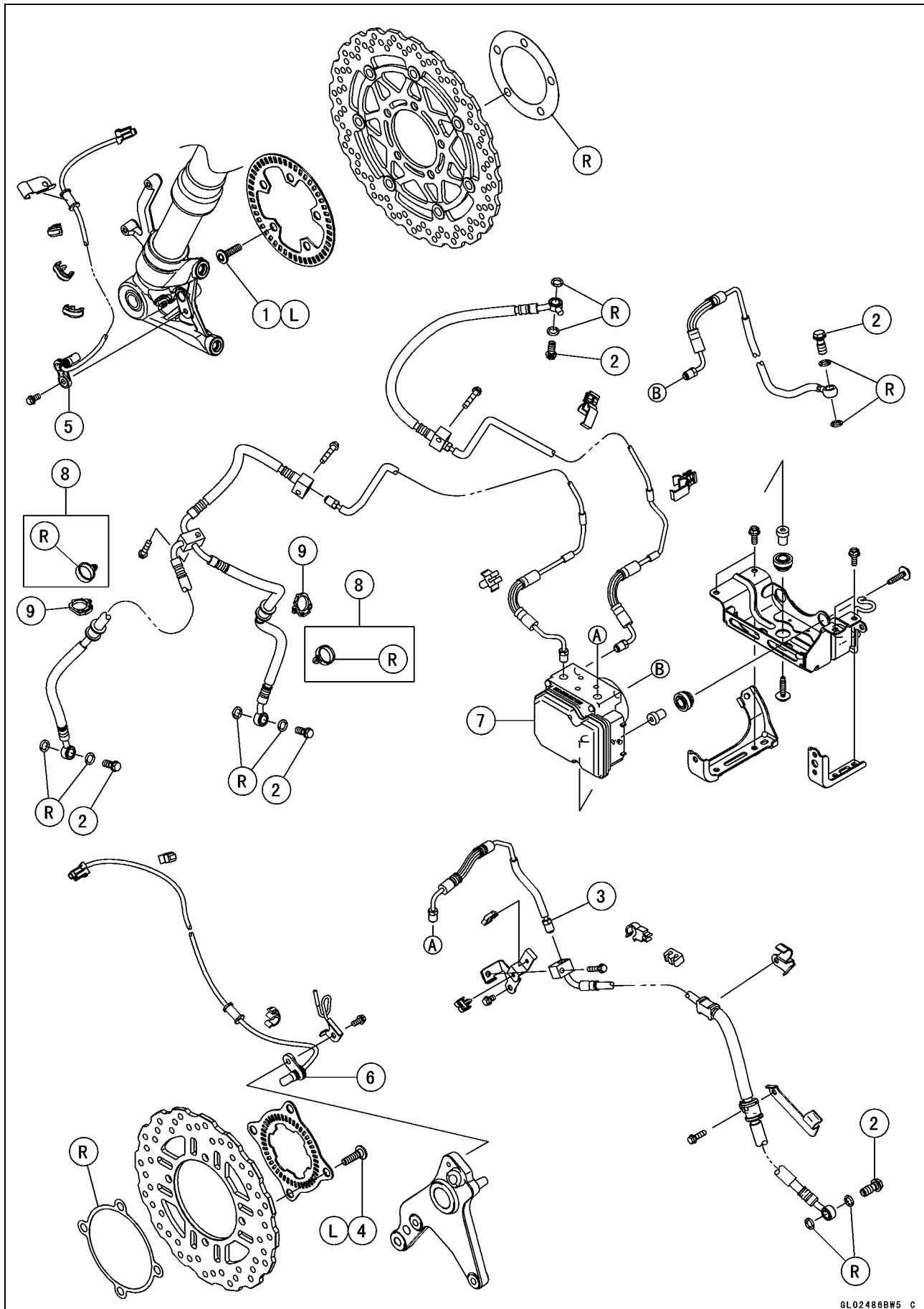

Exploded View

No.	Fastener	Torque			Remarks
		N-m	kgf-m	ft-lb	
1	Front Brake Disc Mounting Bolts	27	2.8	20	L
2	Brake Hose Banjo Bolts	25	2.5	18	
3	Brake Pipe Joint Nuts	18	1.8	13	
4	Rear Brake Disc Mounting Bolts	27	2.8	20	L

- 5. Front Wheel Rotation Sensor
- 6. Rear Wheel Rotation Sensor
- 7. ABS Hydraulic Unit
- 8. ZX1000HB Early Model
- 9. Face the lock portion of the clamp backward.
- L: Apply a non-permanent locking agent.
- R: Replacement Parts

NOTE

○ *When disassembling the brake hose and pipe, disassemble them by the unit as shown in the exploded view.*

12-10 BRAKES

Specifications

Item	Standard	Service Limit
Brake Lever, Brake Pedal		
Brake Lever Position	6-way adjustable (to suit rider)	— — —
Brake Lever Free Play	Non-adjustable	— — —
Pedal Free Play	Non-adjustable	— — —
Pedal Position	About 62 mm (2.4 in.) below footpeg top	— — —
Brake Pads		
Lining Thickness:		
Front	4.0 mm (0.16 in.)	1 mm (0.04 in.)
Rear	5.0 mm (0.20 in.)	1 mm (0.04 in.)
Brake Discs		
Thickness:		
Front	5.3 ~ 5.7 mm (0.21 ~ 0.22 in.)	5.0 mm (0.20 in.)
Rear	5.8 ~ 6.2 mm (0.23 ~ 0.24 in.)	5.5 mm (0.22 in.)
Runout	TIR 0.15 mm (0.006 in.) or less	TIR 0.3 mm (0.01 in.)
Brake Fluid		
Grade	DOT4	— — —
ABS (Equipped Models)		
Wheel Rotation Sensor Air Gap:		
Front	1.98 ~ 2.86 mm (0.0780 ~ 0.113 in.)	— — —
Rear	1.12 ~ 1.85 mm (0.0441 ~ 0.0728 in.)	— — —

Special Tools

**Jack:
57001-1238**

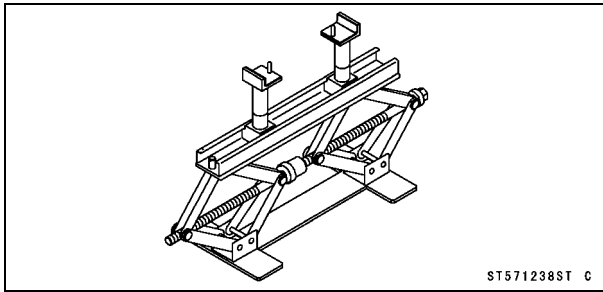

**Jack Attachment:
57001-1608**

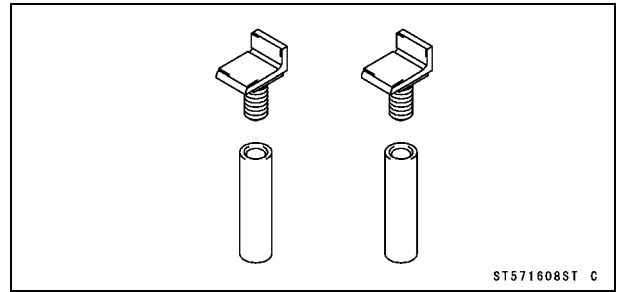

**Attachment Jack:
57001-1252**

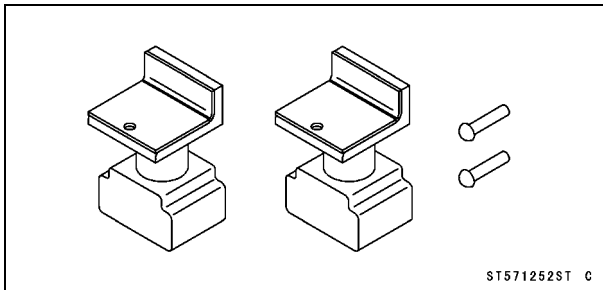

12-12 BRAKES

Brake Lever, Brake Pedal

Brake Lever Position Adjustment

The brake lever adjuster has 6 positions so that the brake lever position can be adjusted to suit the operator's hand.

- Push the lever forward and turn the adjuster [A] to align the number with the arrow mark [B] on the lever holder.
- The distance from the grip to the lever is minimum at number 6 and maximum at number 1.

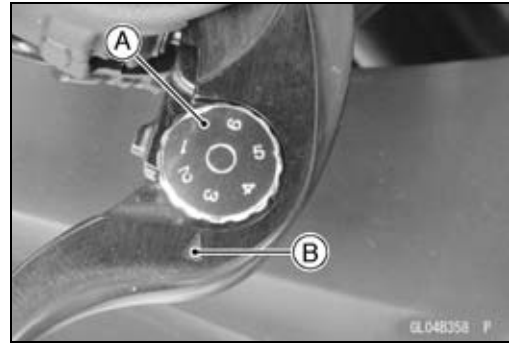

Brake Pedal Position Inspection

- Check that the brake pedal [A] is in the correct position. [B] Footpeg

Pedal Position

Standard: About 62 mm (2.4 in.) [C] below top of footpeg

- ★ If it is incorrect, adjust the brake pedal position.

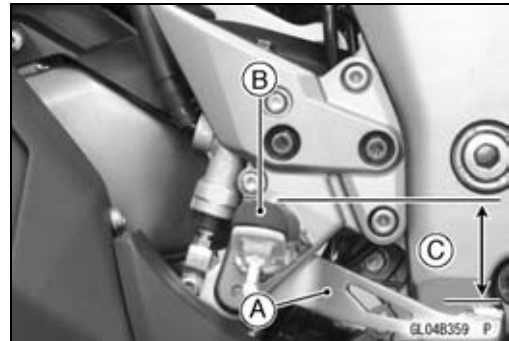

Brake Pedal Position Adjustment

NOTE

○ Usually it is not necessary to adjust the pedal position, but always adjust it when the push rod locknut has been loosened.

- Loosen the locknut [A] and turn the push rod with the hex head [B] to achieve the correct pedal position.
- ★ If the length [C] shown is 70 ± 1 mm (2.76 ± 0.04 in.), the pedal position will be within the standard range.
- Tighten:

Torque - Rear Master Cylinder Push Rod Locknut: 17 N·m (1.7 kgf·m, 12 ft·lb)

- Check the brake light switch operation (see Brake Light Switch Operation Inspection in the Periodic Maintenance chapter).

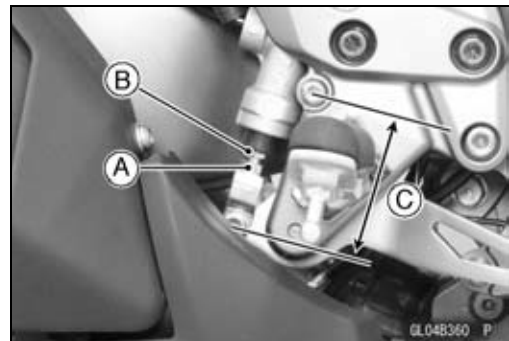

Brake Pedal Removal

- Remove:
 - Rear Lower Fairing (see Rear Lower Fairing Removal in the Frame chapter)
 - Right Front Footpeg Bracket Bolts [A]

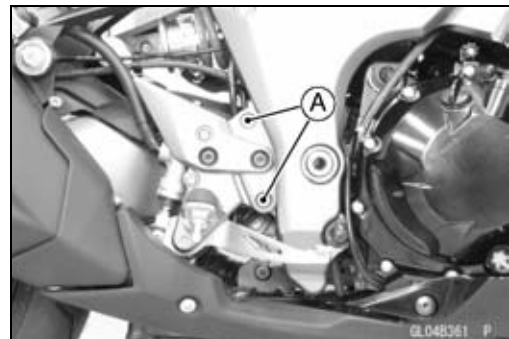

Brake Lever, Brake Pedal

- Remove:
 - Cotter Pin [A]
 - Joint Pin [B]
 - Rear Brake Light Switch Spring [C]
 - Return Spring [D]
 - Brake Pedal Bolt [E]
 - Brake Pedal [F]

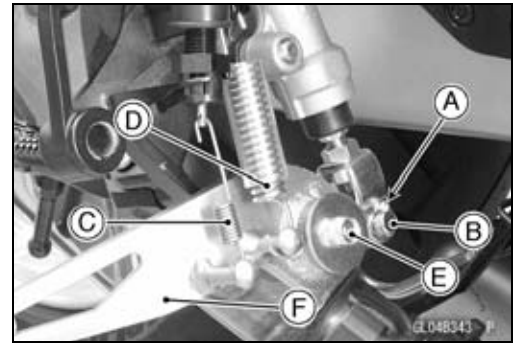

Brake Pedal Installation

- Apply grease to the footpeg pivot shaft [A].
- Install:
 - Washer [B]
 - Brake Pedal [C]
 - Washer [D]
- Apply a non-permanent locking agent to the threads of the brake pedal bolt [E], and tighten it.

Torque - Brake Pedal Bolt: 8.8 N·m (0.90 kgf·m, 78 in·lb)

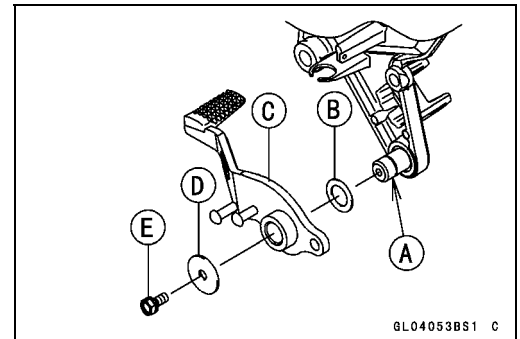

- Hook the longer end of the rear brake light switch spring [A] on the brake light switch.
- Hook the upper end of the return spring [B] on the footpeg bracket hook.
- Face the both lower spring ends forward.

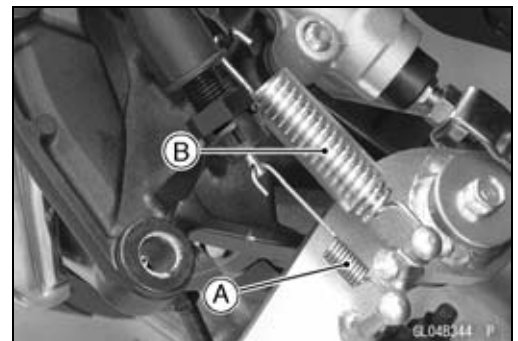

- Replace the cotter pin [A] with a new one.
- Insert the cotter pin and bend the pin ends [B].
- Install the front footpeg bracket.
- Tighten:

Torque - Front Footpeg Bracket Bolts: 25 N·m (2.5 kgf·m, 18 ft·lb)

- Check the brake pedal position (see Brake Pedal Position Inspection).

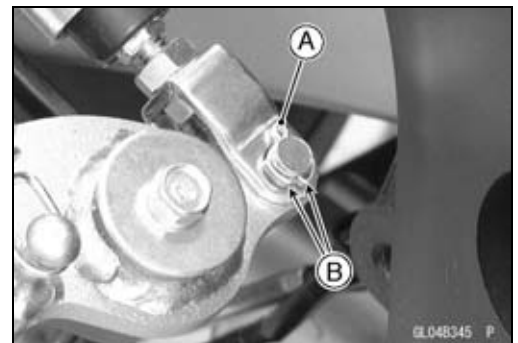

12-14 BRAKES

Calipers

Front Caliper Removal

- Loosen the banjo bolt [A] at the brake hose lower end, and tighten it loosely.
- Unscrew the caliper mounting bolts [B], and detach the caliper [C] from the disc.

NOTICE

Do not loosen the caliper assembly bolts [D]. Take out only the caliper mounting bolts for caliper removal. Loosening the caliper assembly bolts will cause brake fluid leakage.

- Unscrew the banjo bolt and remove the brake hose [E] from the caliper (see Brake Hose and Pipe Replacement in the Periodic Maintenance chapter).

NOTICE

Immediately wash away any brake fluid that spills.

NOTE

○ If the caliper is to be disassembled after removal and if compressed air is not available, disassemble the caliper before the brake hose is removed (see Caliper Rubber Parts Replacement in the Periodic Maintenance chapter).

- Remove the collars [A] from the fork leg.

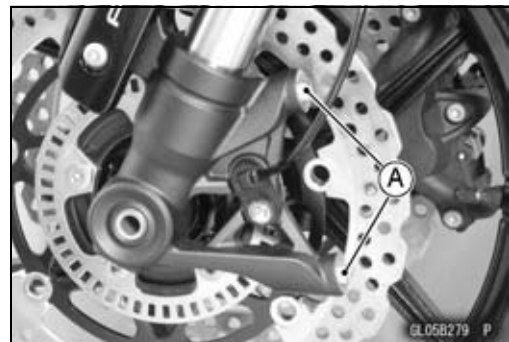
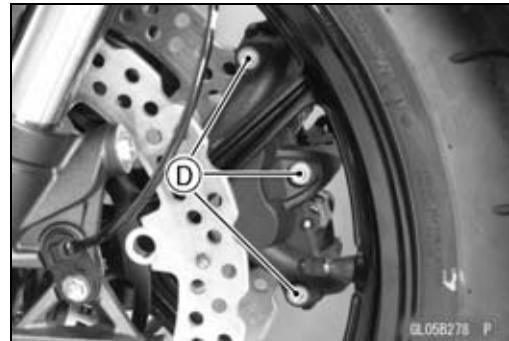
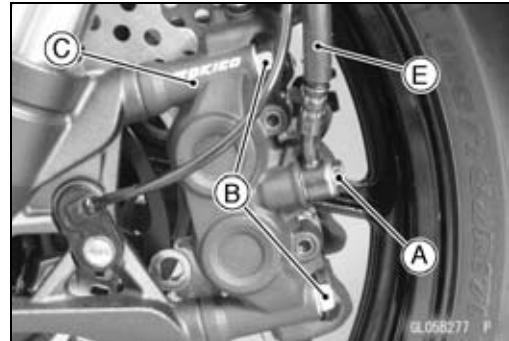

Rear Caliper Removal

- Loosen the banjo bolt [A] at the brake hose lower end, and tighten it loosely.
- Unscrew the caliper mounting bolts [B], and detach the caliper [C] from the disc.
- Unscrew the banjo bolt and remove the brake hose [D] from the caliper (see Brake Hose and Pipe Replacement in the Periodic Maintenance chapter).

NOTICE

Immediately wash away any brake fluid that spills.

NOTE

○ If the caliper is to be disassembled after removal and if compressed air is not available, disassemble the caliper before the brake hose is removed (see Caliper Rubber Parts Replacement in the Periodic Maintenance chapter).

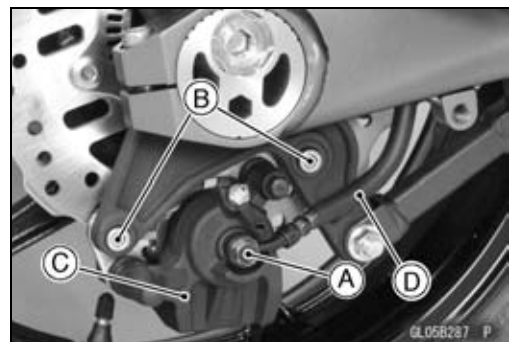

Calipers

Caliper Installation

- Install the caliper and brake hose lower end.
- For the front caliper, install the collars [A] on the fork leg and fit the holes [B] of the front caliper to the collars.
- Replace the washers on each side of hose fitting with new ones.

- Tighten:

Torque - Caliper Mounting Bolts

Front: 34 N·m (3.5 kgf·m, 25 ft·lb)

Rear: 25 N·m (2.5 kgf·m, 18 ft·lb)

Brake Hose Banjo Bolts: 25 N·m (2.5 kgf·m, 18 ft·lb)

- Bleed the brake line (see Brake Line Bleeding).
- Check the brake for good braking power, no brake drag, and no fluid leakage.

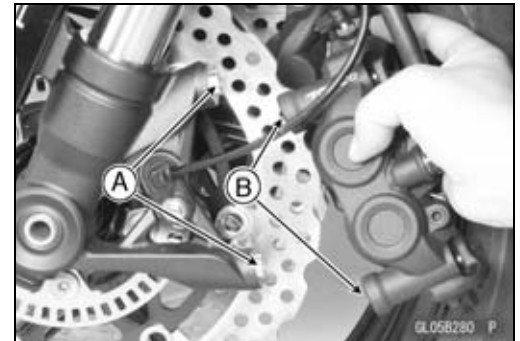

⚠ WARNING

After servicing, it takes several applications of the brake lever or pedal before the brake pads contact the disc, which could result in increased stopping distance and cause an accident resulting in injury or death. Do not attempt to ride the motorcycle until a firm brake lever or pedal is obtained by pumping the lever or pedal until the pads are against the disc.

Front Caliper Disassembly

- Refer to the Caliper Rubber Parts Replacement in the Periodic Maintenance chapter.

Front Caliper Assembly

- Refer to the Caliper Rubber Parts Replacement in the Periodic Maintenance chapter.

Rear Caliper Disassembly

- Refer to the Caliper Rubber Parts Replacement in the Periodic Maintenance chapter.

Rear Caliper Assembly

- Refer to the Caliper Rubber Parts Replacement in the Periodic Maintenance chapter.

12-16 BRAKES

Calipers

Caliper Fluid Seal Damage

The fluid seal (piston seal) [A] is placed around the piston to maintain clearance between the pad and the disc. If the seal is in a poor condition, it could lead the pad to wear excessively or the brake to drag, which may cause the temperature of the discs or the brake fluid to increase.

● Replace the fluid seal if it exhibits any of the conditions listed below.

- Brake fluid leakage around the pad.
- Brakes overheat.
- Considerable difference in inner and outer pad wear.
- Seal and piston are stuck together.

★ If the fluid seal is replaced, replace the dust seal [B] as well. Also, replace all seals every other time the pads are changed.

Front Caliper [C]

Rear Caliper [D]

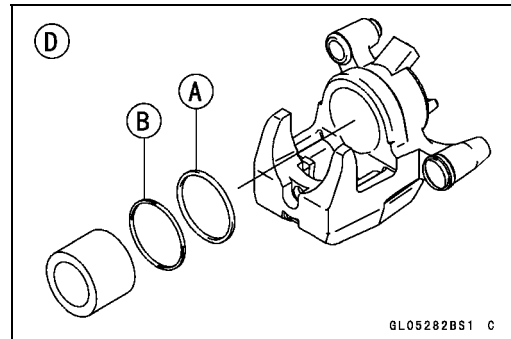
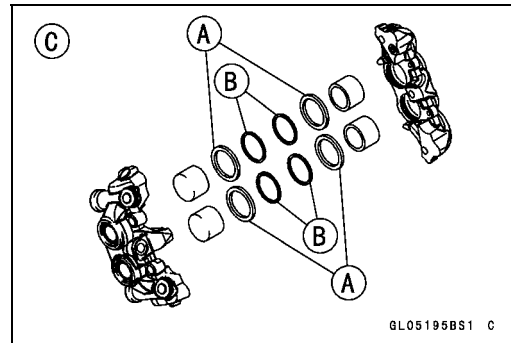

Rear Caliper Dust Boot and Friction Boot Damage

● Check that the dust boot [A] and friction boot [B] are not cracked, worn, swollen, or otherwise damaged.

★ If they show any damage, replace it.

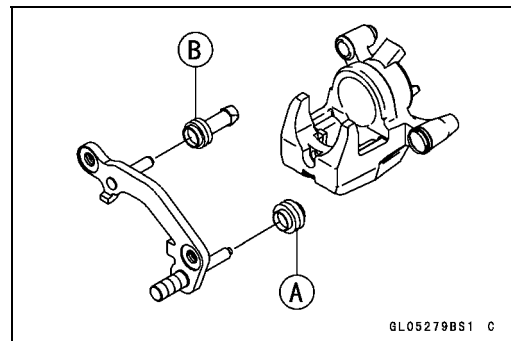

Caliper Piston and Cylinder Damage

● Visually inspect the pistons [A] and cylinder surfaces [B].

★ Replace the caliper if the cylinder and piston are badly scored or rusty.

Front Caliper [C]

Rear Caliper [D]

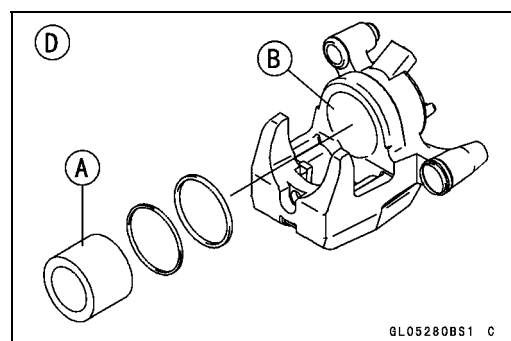
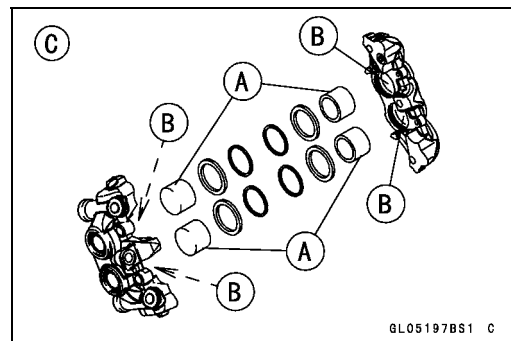

Calipers

Rear Caliper Holder Shaft Wear

The caliper body must slide smoothly on the caliper holder shafts [A]. If the body does not slide smoothly, one pad will wear more than the other, pad wear will increase, and constant drag on the disc will raise brake and brake fluid temperature.

- Check to see that the caliper holder shafts are not badly worn or stepped, and that the rubber friction boots are not damaged.
- ★ If the rubber friction boot is damaged, replace the rubber friction boot. To replace the friction boot, remove the pads and the caliper bracket.
- ★ If the caliper holder shaft is damaged, replace the caliper bracket.

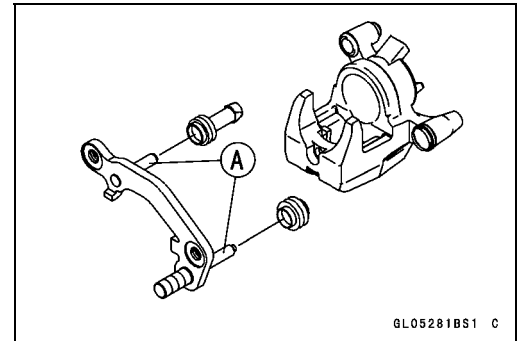

12-18 BRAKES

Brake Pads

Front Brake Pad Removal

- Loosen the pad pins [A].



- Remove the front caliper with the hose installed (see Front Caliper Removal).
- Remove:
 - Pad Pins [A]
 - Brake Pads [B]

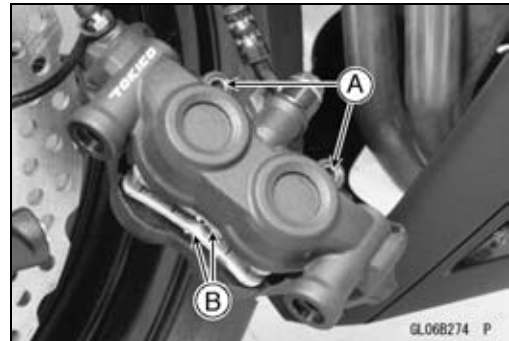

Front Brake Pad Installation

- Check that the pad spring [A] is in place on the caliper.
- Push the caliper pistons in by hand as far as they will go.

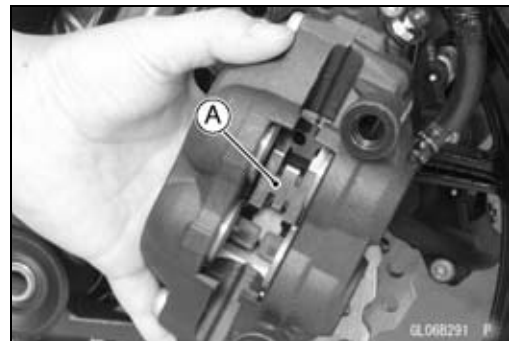

- Install the brake pads [A] on the pad spring correctly.
- Fit the pad into the groove of the caliper as shown in the figure.
- Install the pad pins while pushing the brake pads lightly.
- Tighten the pad pins temporarily.
- Install the front caliper (see Caliper Installation).
- Tighten:

Torque - Front Brake Pad Pins: 15 N·m (1.5 kgf·m, 11 ft·lb)

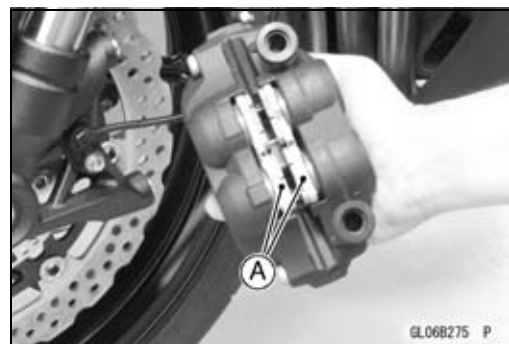

⚠ WARNING

After servicing, it takes several applications of the brake lever before the brake pads contact the disc, which could result in increased stopping distance and cause an accident resulting in injury or death. Do not attempt to ride the motorcycle until a firm brake lever is obtained by pumping the lever until the pads are against the disc.

Brake Pads

Rear Brake Pad Removal

- Remove the rear caliper with the hose installed (see Rear Caliper Removal).
- Remove:
 - Clip [A]
 - Pad Pin [B]
- Remove the brake pad [C] of the jaw side from the holder shaft [D], then remove the other pad [E].

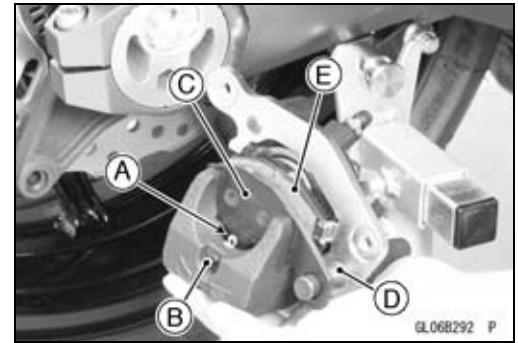

Rear Brake Pad Installation

- Check that the pad spring [A], guide [B] and insulator [C] are in place on the caliper and holder.
- Push the caliper piston in by hand as far as it will go.

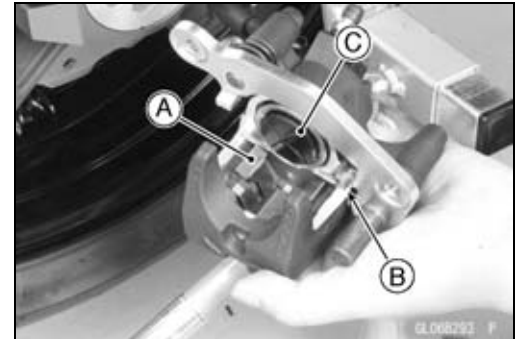

- Install the brake pad [A] on the piston side first, then install the other pad on the holder shaft.
- Fit the projections [B] of the piston side pad into the recesses [C] of the caliper holder.
- Install the pad pin while pushing the brake pad of the jaw side lightly.
- Install a new clip.
- The clip must be “outside” of the pad.
- Install the rear caliper (see Rear Caliper Installation).

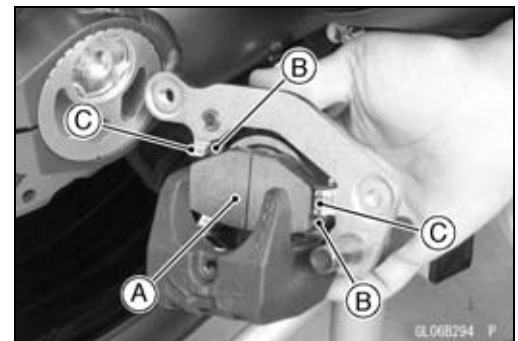

⚠ WARNING

After servicing, it takes several applications of the brake pedal before the brake pads contact the disc, which could result in increased stopping distance and cause an accident resulting in injury or death. Do not attempt to ride the motorcycle until a firm brake pedal is obtained by pumping the pedal until the pads are against the disc.

Brake Pad Wear Inspection

- Refer to the Brake Pad Wear Inspection in the Periodic Maintenance chapter.

12-20 BRAKES

Master Cylinder

Front Master Cylinder Removal

- Remove the rear view mirror (see Rear View Mirror Removal in the Frame chapter).
- Remove the banjo bolt [A] to disconnect the brake hose from the master cylinder (see Brake Hose Removal/Installation).
- Unscrew the clamp bolts [B], and take off the master cylinder [C] as an assembly with the reservoir, brake lever, and brake switch installed.
- Disconnect the front brake light switch connector [D].

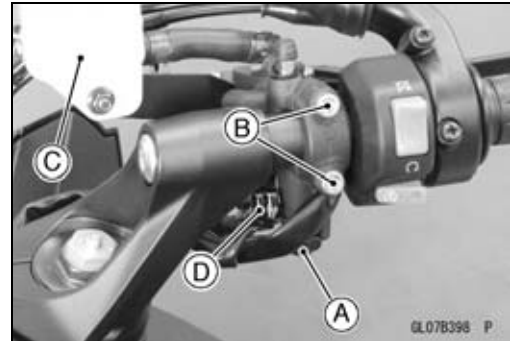

NOTICE

Immediately wash away any brake fluid that spills.

Front Master Cylinder Installation

- Set the front master cylinder to match its mating surface [A] to the punch mark [B] of the handlebar.
- The master cylinder clamp must be installed with the arrow mark [C] upward.
- Tighten the upper clamp bolt first, and then the lower clamp bolt.

Torque - Front Master Cylinder Clamp Bolts: 11 N·m (1.1 kgf·m, 97 in·lb)

- Replace the washers that are on each side of the hose fitting with new ones.
- Tighten:
 - Torque - Brake Hose Banjo Bolts: 25 N·m (2.5 kgf·m, 18 ft·lb)**
- Bleed the brake line (see Brake Line Bleeding).
- Check the brake for good braking power, no brake drag, and no fluid leakage.

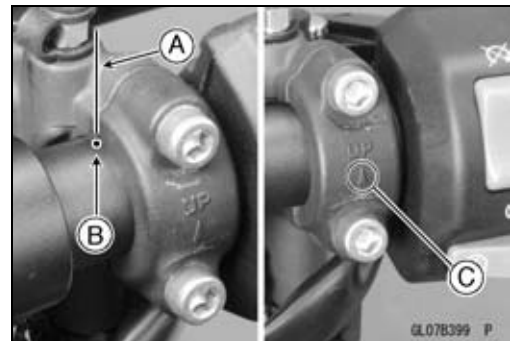

Rear Master Cylinder Removal

- Remove the rear lower fairing (see Rear Lower Fairing Removal in the Frame chapter).
- Loosen:
 - Brake Hose Banjo Bolt [A]
 - Rear Master Cylinder Mounting Bolts [B]
- Remove the footpeg bracket bolts [C].

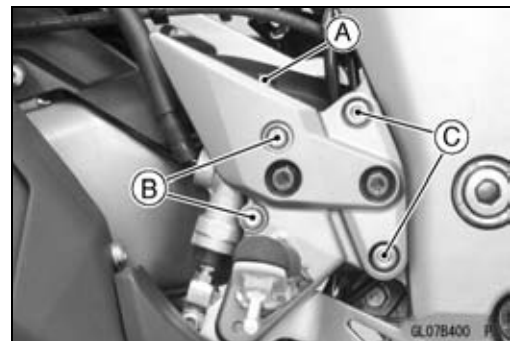

- Remove:
 - Rear Master Cylinder Mounting Bolts [A]
 - Cotter Pin [B]
 - Joint Pin [C]
 - Brake Hose Banjo Bolt [D]
 - Brake Hose [E]
- Slide out the clamp [F].
- Pull off the reservoir hose lower end, and drain the brake fluid into a container.

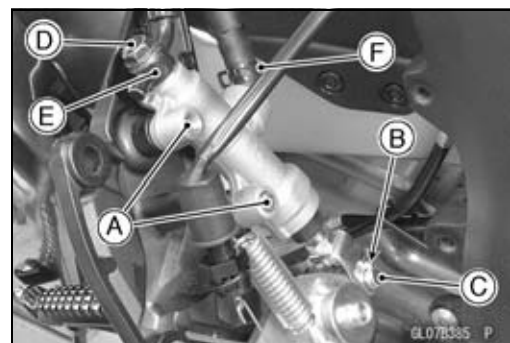

Master Cylinder

Rear Master Cylinder Installation

- Replace the cotter pin [A] with a new one.
- Insert the cotter pin and bend the pin ends [B].

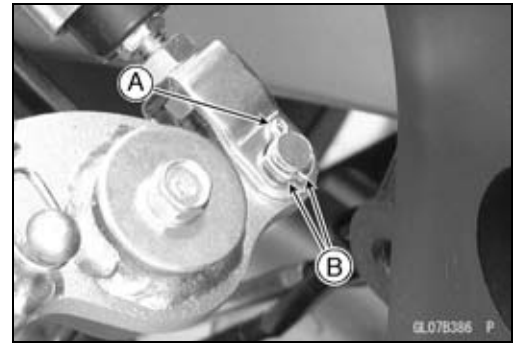

- Replace the washers on each side of hose fitting with new ones.
- Depress the brake pedal [A] to align the holes of the master cylinder, then install the master cylinder mounting bolts [B].
- Tighten the following bolts.

Torque - Front Footpeg Bracket Bolts: 25 N·m (2.5 kgf·m, 18 ft·lb)

Rear Master Cylinder Mounting Bolts: 25 N·m (2.5 kgf·m, 18 ft·lb)

Brake Hose Banjo Bolts: 25 N·m (2.5 kgf·m, 18 ft·lb)

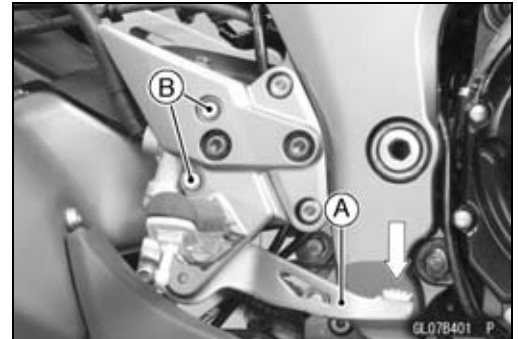

NOTE

○After installation, check that the rear brake light switch spring is hooked on the return spring.

- Bleed the brake line (see Brake Line Bleeding).
- Check the brake for good braking power, no brake drag, and no fluid leakage.

Front Master Cylinder Disassembly

- Refer to the Master Cylinder Rubber Parts Replacement in the Periodic Maintenance chapter.

Rear Master Cylinder Disassembly

- Refer to the Master Cylinder Rubber Parts Replacement in the Periodic Maintenance chapter.

Master Cylinder Assembly

- Refer to the Master Cylinder Rubber Parts Replacement in the Periodic Maintenance chapter.

12-22 BRAKES

Master Cylinder

Master Cylinder Inspection (Visual Inspection)

- Remove the master cylinders (see Front/Rear Master Cylinder Removal).
- Disassemble the front and rear master cylinders (see Master Cylinder Rubber Parts Replacement in the Periodic Maintenance chapter).
- Check that there are no scratches, rust or pitting on the inner wall [A] of each master cylinder and on the outside of each piston [B].
- ★ If a master cylinder or piston shows any damage, replace them.
- Inspect the primary cup [C] and secondary cup [D].
- ★ If a cup is worn, damaged softened (rotted), or swollen, the piston assembly should be replaced to renew the cups.
- ★ If fluid leakage is noted at the brake lever, the piston assembly should be replaced to renew the cups.
- Check the dust covers [E] for damage.
- ★ If they are damaged, replace them.
- Check the piston return springs [F] for any damage.
- ★ If the springs are damaged, replace them.
- Check that relief port [G] and supply port [H] are not plugged.
- ★ If the relief port becomes plugged, the brake pads will drag on the disc. Blow the ports clean with compressed air.

Front Master Cylinder [J]

Rear Master Cylinder [K]

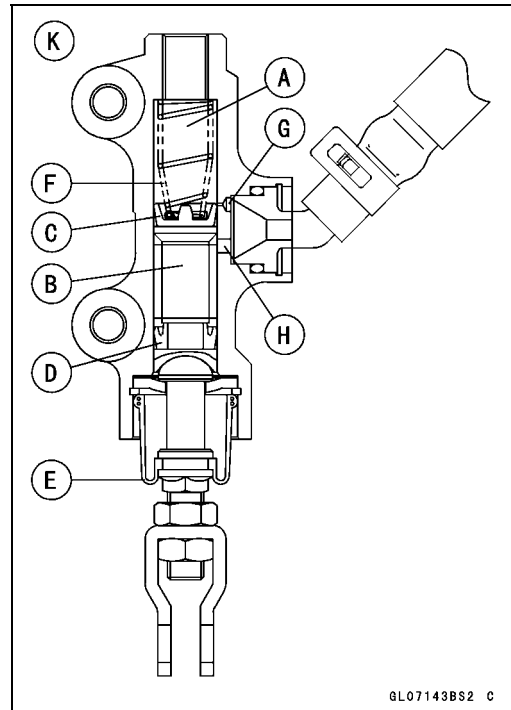
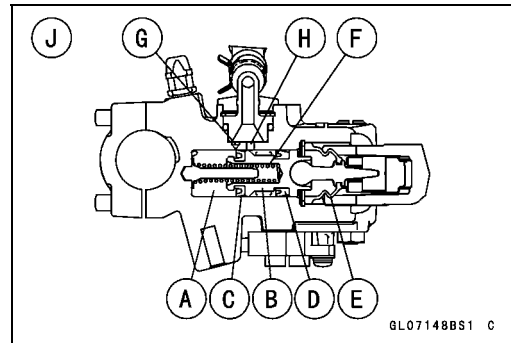

Brake Disc

Brake Disc Removal

- Remove the wheels (see Front/Rear Wheel Removal in the Wheels/Tires chapter).
- Unscrew the mounting bolts [A], and take off the disc [B].
- Remove the gaskets.

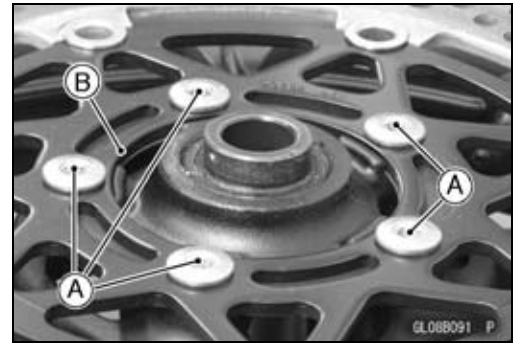

Brake Disc Installation

- Replace the gaskets with new ones.
- Install the brake disc on the wheel so that the marked side [A] faces out.
- Apply a non-permanent locking agent to the threads of the front and rear brake disc mounting bolts, and tighten them.

Torque - Brake Disc Mounting Bolts: 27 N·m (2.8 kgf·m, 20 ft·lb)

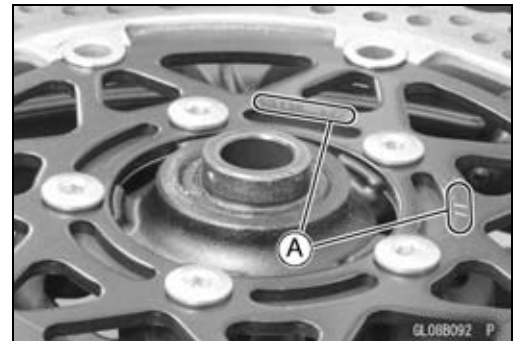

Brake Disc Wear

- Measure the thickness of each disc [A] at the point where it has worn the most.
 - ★ If the disc has worn past the service limit, replace it.
- Measuring Area [B]

Brake Discs Thickness

Standard:

Front 5.3 ~ 5.7 mm (0.21 ~ 0.22 in.)

Rear 5.8 ~ 6.2 mm (0.23 ~ 0.24 in.)

Service Limit:

Front 5.0 mm (0.20 in.)

Rear 5.5 mm (0.22 in.)

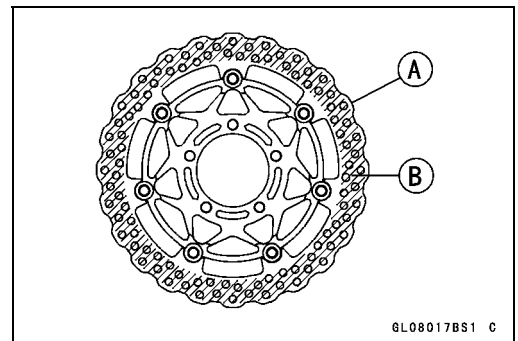

Brake Disc Warp

- Raise the front/rear wheel off the ground.

Special Tools - Jack: 57001-1238

Attachment Jack: 57001-1252

Jack Attachment: 57001-1608

- For front disc inspection, turn the handlebar fully to one side.

- Set up a dial gauge against the disc [A] as shown in the figure and measure disc runout, while turning [B] the wheel by hand.

- ★ If runout exceeds the service limit, replace the disc.

Disc Runout

Standard: TIR 0.15 mm (0.006 in.) or less

Service Limit: TIR 0.3 mm (0.01 in.)

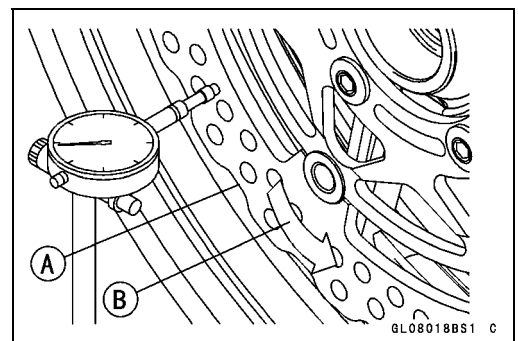

12-24 BRAKES

Brake Fluid

Brake Fluid Level Inspection

- Refer to the Brake Fluid Level Inspection in the Periodic Maintenance chapter.

Brake Fluid Change

- Refer to the Brake Fluid Change in the Periodic Maintenance chapter.

Brake Line Bleeding

The brake fluid has a very low compression coefficient so that almost all the movement of the brake lever or pedal is transmitted directly to the caliper for braking action. Air, however, is easily compressed. When air enters the brake lines, brake lever or pedal movement will be partially used in compressing the air. This will make the lever or pedal feel spongy, and there will be a loss in braking power.

⚠ WARNING

Air in the brake lines diminish braking performance and can cause an accident resulting in injury or death. If the brake lever or pedal has a soft or "spongy" feeling mushy when it is applied, there might be air in the brake lines or the brake may be defective. Do not operate the vehicle and service the brake system immediately.

NOTE

- *The procedure to bleed the front brake line is as follows. Bleeding the rear brake line is the same as for the front brake.*

- Remove:
 - Screw [A]
 - Stopper [B]
 - Front Brake Reservoir Cap [C]
 - Diaphragm Plate
 - Diaphragm
- Fill the reservoir with fresh brake fluid to the upper level line in the reservoir.
- Slowly pump the brake lever several times until no air bubbles can be seen rising up through the fluid from the holes at the bottom of the reservoir.
- Bleed the air completely from the master cylinder by this operation.

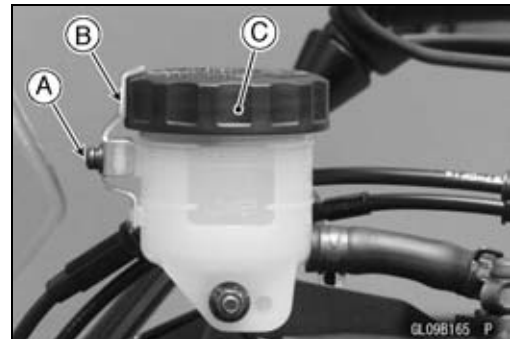

Brake Fluid

- Remove the rubber cap from the bleed valve on the front master cylinder.
- Attach a clear plastic hose [A] to the bleed valve, and run the other end of the hose into a container.

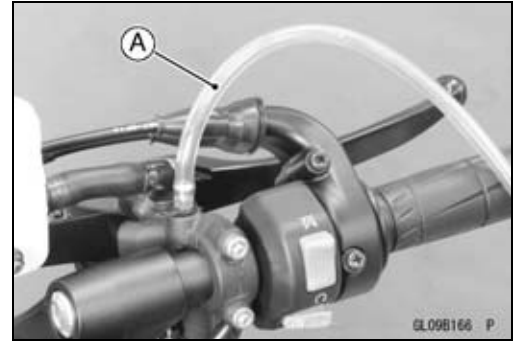

- Bleed the brake line and the master cylinder.
- Repeat this operation until no more air can be seen coming out into the plastic hose.
 1. Pump the brake lever until it becomes hard, and apply the brake and hold it [A].
 2. Quickly open and close [B] the bleed valve while holding the brake applied.
 3. Release the brake [C].

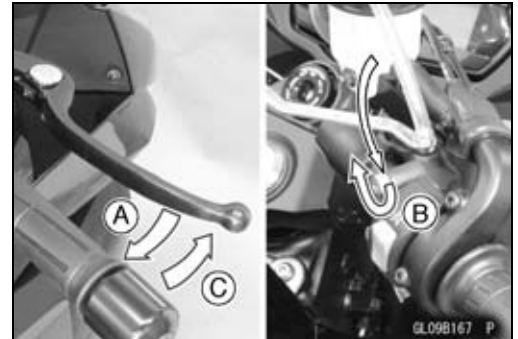

NOTE

- *The fluid level must be checked often during the bleeding operation and replenished with fresh brake fluid as necessary. If the fluid in the reservoir runs completely out any time during bleeding, the bleeding operation must be done over again from the beginning since air will have entered the line.*

- Remove the clear plastic hose.
- Tighten the bleed valve, and install the rubber cap.

Torque - Front Master Cylinder Bleed Valve: 5.4 N·m (0.55 kgf·m, 48 in·lb)

- Remove the rubber cap [A] from the bleed valve on the caliper.
- Attach a clear plastic hose [B] to the bleed valve, and run the other end of the hose into a container.

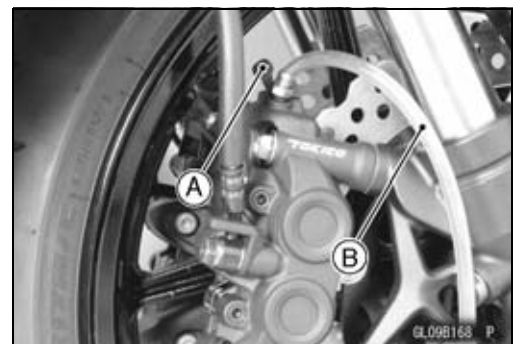

12-26 BRAKES

Brake Fluid

- Bleed the brake line and the caliper.
- Repeat this operation until no more air can be seen coming out into the plastic hose.
 1. Pump the brake lever until it becomes hard, and apply the brake and hold it [A].
 2. Quickly open and close [B] the bleed valve while holding the brake applied.
 3. Release the brake [C].

NOTE

- The fluid level must be checked often during the bleeding operation and replenished with fresh brake fluid as necessary. If the fluid in the reservoir runs completely out any time during bleeding, the bleeding operation must be done over again from the beginning since air will have entered the line.
- Tap the brake hose lightly from the caliper to the reservoir for more complete bleeding.
- Front Brake: First bleeding the right caliper then repeat the above steps for the left caliper.



- Remove the clear plastic hose.
- Install:
 - Diaphragm
 - Diaphragm Plate
 - Front Brake Reservoir Cap
- Follow the procedure below to install the front/rear brake fluid reservoir cap correctly.
- First, tighten the brake fluid reservoir cap [B] clockwise [C] by hand until slight resistance is felt indicating that the cap is seated on the reservoir body, then tighten the cap an additional 1/6 turn [D] while holding the brake fluid reservoir body [A].
- Tighten the rear brake reservoir cap stopper screw securely.

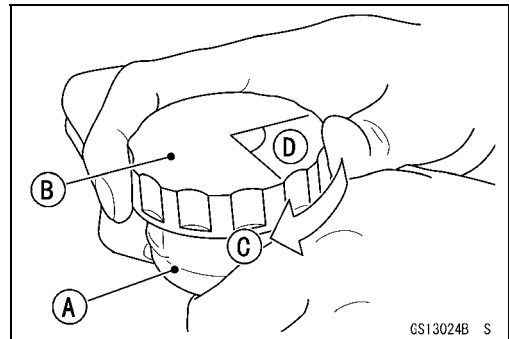

- Tighten:
 - Torque - Front Master Cylinder Reservoir Cap Stopper Screw: 1.2 N·m (0.12 kgf·m, 11 in·lb)**
- Tighten the bleed valve, and install the rubber cap.
 - Torque - Bleed Valves: 7.8 N·m (0.80 kgf·m, 69 in·lb)**
- Check the fluid level (see Brake Fluid Level Inspection in the Periodic Maintenance chapter).
- After bleeding is done, check the brake for good braking power, no brake drag, and no fluid leakage.

Brake Fluid

 WARNING

When working with the disc brake, observe the precautions listed below.

1. Never reuse old brake fluid.
2. Do not use fluid from a container that has been left unsealed or that has been open for a long time.
3. Do not mix two types and brands of fluid for use in the brake. This lowers the brake fluid boiling point and could cause the brake to be ineffective. It may also cause the rubber brake parts to deteriorate.
4. Don't leave the reservoir cap off for any length of time to avoid moisture contamination of the fluid.
5. Don't change the fluid in the rain or when a strong wind is blowing.
6. Except for the disc pads and disc, use only disc brake fluid, isopropyl alcohol, or ethyl alcohol for cleaning of the brake parts. Do not use any other fluid for cleaning these parts. Gasoline, engine oil, or any other petroleum distillate will cause deterioration of the rubber parts. Oil spilled on any part will be difficult to wash off completely and will eventually deteriorate the rubber used in the disc brake.
7. When handling the disc pads or disc, be careful that no disc brake fluid or any oil gets on them. Clean off any fluid or oil that inadvertently gets on the pads or disc with a high-flash point solvent. Do not use one which will leave an oily residue. Replace the pads with new ones if they cannot be cleaned satisfactorily.
8. Brake fluid quickly ruins painted surfaces; any spilled fluid should be completely wiped up immediately.
9. If any of the brake line fittings or the bleed valve is opened at any time, the **AIR MUST BE BLED FROM THE BRAKE LINE.**

12-28 BRAKES

Brake Hose

Brake Hose Removal/Installation

- Refer to the Brake Hose Replacement in the Periodic Maintenance chapter.

Brake Hose and Pipe Inspection

- Refer to the Brake Hose and Pipe Damage and Installation Condition Inspection in the Periodic Maintenance chapter.

Anti-Lock Brake System (Equipped Models)

Parts Location

Front Wheel Rotation Sensor [A]

Front Wheel Rotation Sensor Rotor [B]

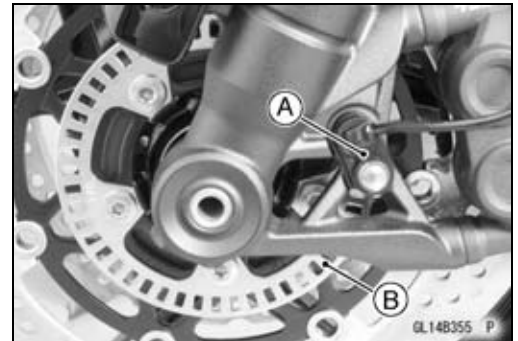

Rear Wheel Rotation Sensor [A]

Rear Wheel Rotation Sensor Rotor [B]

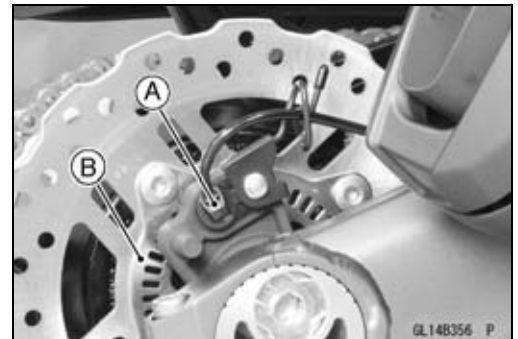

ABS Indicator Light [A]



ABS Hydraulic Unit [A]



Fuse Box 1 [A] (ABS Fuses and Accessory Fuse)

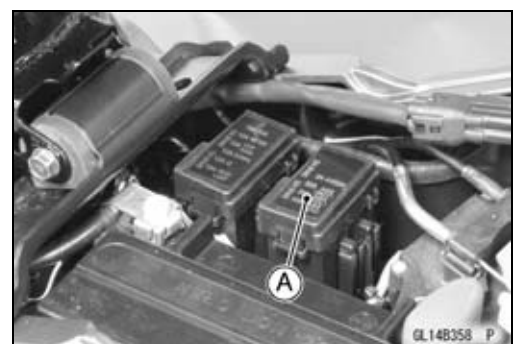

12-30 BRAKES

Anti-Lock Brake System (Equipped Models)

ABS Kawasaki Diagnostic System Connector [A]
ABS Self-diagnosis Terminal [B]

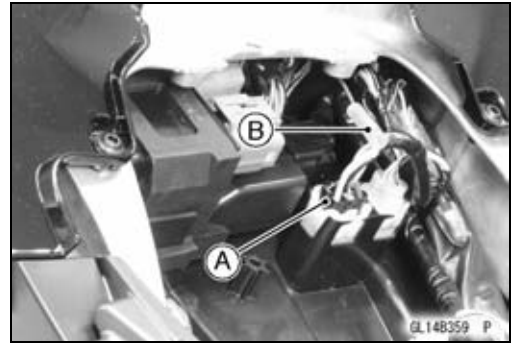

Anti-Lock Brake System (Equipped Models)

ABS System Wiring Diagram

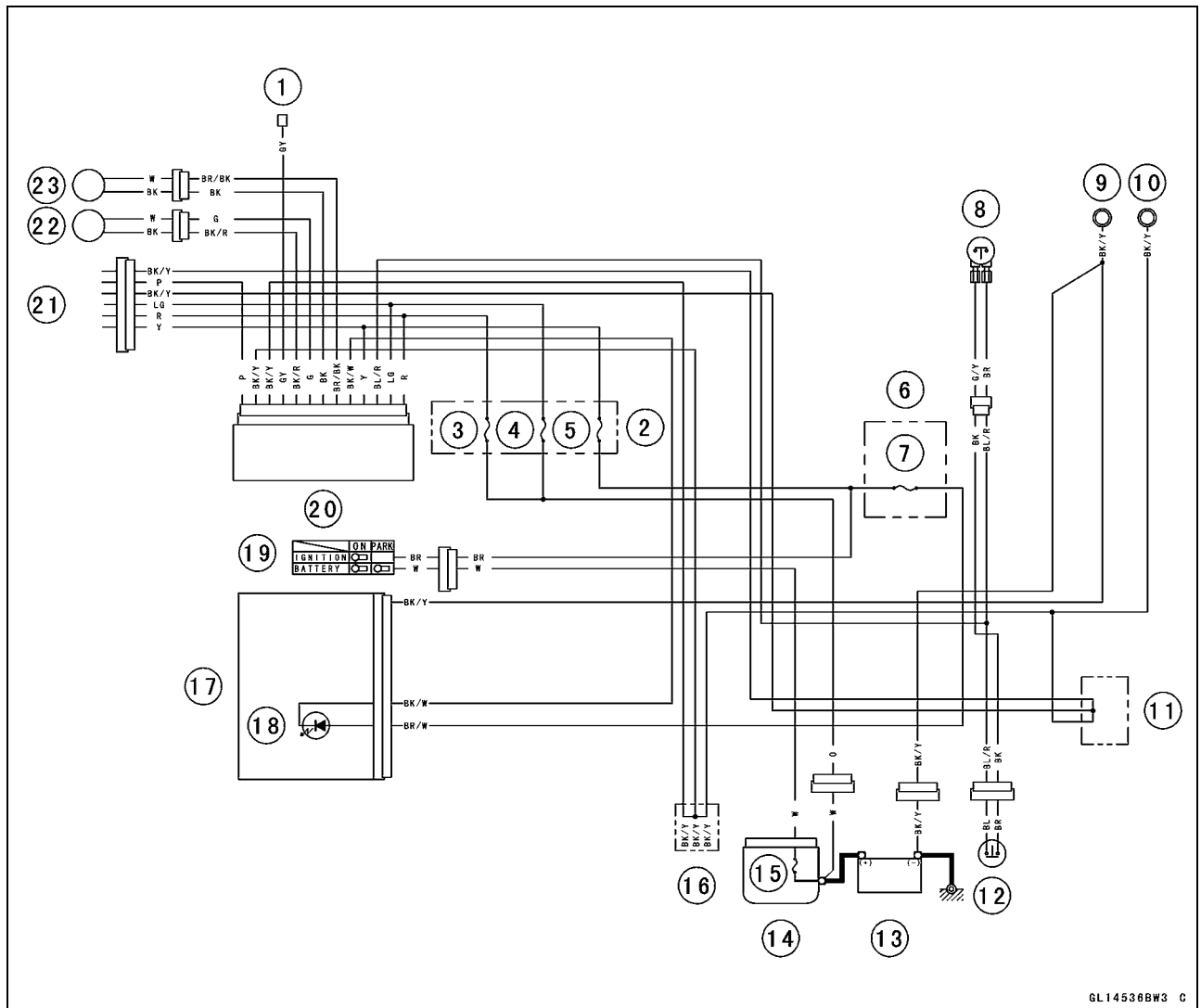

- | | |
|---------------------------------------|--|
| 1. ABS Self-diagnosis Terminal | 13. Battery 12 V 8 Ah |
| 2. Fuse Box 1 | 14. Starter Relay |
| 3. ABS Motor Relay Fuse 30 A | 15. Main Fuse 30 A |
| 4. ABS Solenoid Valve Relay Fuse 20 A | 16. Water-proof Joint D |
| 5. ABS ECU Fuse 10 A | 17. Meter Unit |
| 6. Fuse Box 2 | 18. ABS Indicator Light (LED) |
| 7. Ignition Fuse 10 A | 19. Ignition Switch |
| 8. Front Brake Light Switch | 20. ABS Hydraulic Unit |
| 9. Meter Ground | 21. ABS Kawasaki Self-diagnosis System Connector |
| 10. Frame Ground | 22. Front Wheel Rotation Sensor |
| 11. Water-proof Joint C | 23. Rear Wheel Rotation Sensor |
| 12. Rear Brake Light Switch | |

○Color Codes:

BK: Black	GY: Gray	PU: Purple
BL: Blue	LB: Light Blue	R: Red
BR: Brown	LG: Light Green	V: Violet
CH: Chocolate	O: Orange	W: White
DG: Dark Green	P: Pink	Y: Yellow
G: Green		

12-32 BRAKES

Anti-Lock Brake System (Equipped Models)

ABS Hydraulic Unit Terminal Names

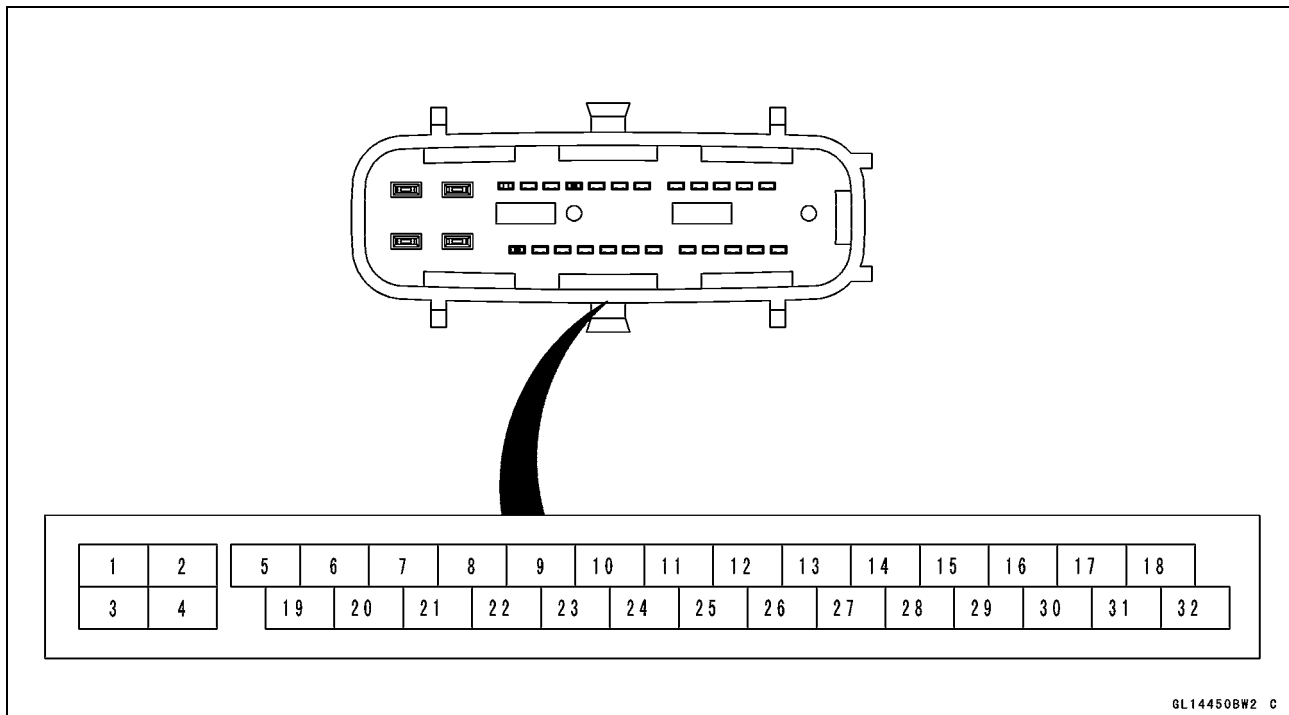

1. Power Supply to ABS Motor
2. Power Supply to ABS Solenoid Valve Relay
3. Ground
4. Ground
5. ABS Self-diagnosis Terminal
6. Unused
7. Unused
8. Front and Rear Brake Light Switch
9. Unused
10. Unused
11. Unused
12. Unused
13. Unused
14. Unused
15. Unused
16. Power Supply
17. Unused
18. Unused
19. Unused
20. Unused
21. Unused
22. Unused
23. Power Supply to Front Wheel Rotation Sensor
24. ABS Kawasaki Self-diagnosis System Terminal
25. ABS Indicator Light (LED)
26. Power Supply to Rear Wheel Rotation Sensor
27. Front Wheel Rotation Sensor Signal
28. Unused
29. Unused
30. Rear Wheel Rotation Sensor Signal
31. Unused
32. Unused

Anti-Lock Brake System (Equipped Models)

ABS Servicing Precautions

There are a number of important precautions that should be followed servicing the ABS system.

- This ABS system is designed to be used with a 12 V sealed battery as its power source. Do not use any other battery except for a 12 V sealed battery as a power source.
- Do not reverse the battery cable connections. This will damage the ABS hydraulic unit.
- To prevent damage to the ABS parts, do not disconnect the battery cables or any other electrical connections when the ignition switch is ON or while the engine is running.
- Take care not to short the leads that are directly connected to the battery positive (+) terminal to the chassis ground.
- Do not turn the ignition switch ON while any of the ABS electrical connectors are disconnected. The ABS hydraulic unit memorizes service codes.
- Do not spray water on the electrical parts, ABS parts, connectors, leads and wiring.
- If a transceiver is installed on the motorcycle, make sure that the operation of the ABS system is not influenced by electric wave radiated from the antenna. Locate the antenna as far as possible away from the ABS hydraulic unit.
- Whenever the ABS electrical connections are to be disconnected, first turn off the ignition switch.
- The ABS parts should never be struck sharply, as with a hammer, or allowed to fall on a hard surface. Such a shock to the parts can damage them.
- The ABS parts cannot be disassembled. Even if a fault is found, do not try to disassemble and repair the ABS parts, replace it.
- The ABS has many brake lines, pipes, and leads. And the ABS cannot detect problems with the conventional braking system (brake disc wear, unevenly worn brake pad, and other mechanical faults). To prevent trouble, check the brake lines and pipes for correct routing and connection, the wiring for correct routing, and the brakes for proper braking power. Be sure to check for fluid leakage, and bleed the brake line thoroughly.

12-34 BRAKES

Anti-Lock Brake System (Equipped Models)

⚠ WARNING

Air in the brake lines diminish braking performance and can cause an accident resulting in injury or death. If any of the brake line fittings, including the ABS hydraulic unit joint nuts, or the bleed valve is opened at any time, the air must be bled completely from the brake line. If the brake lever has a soft or "spongy" feeling mushy when it is applied, there might be air in the brake lines or the brake may be defective. Do not operate the vehicle and service the brake system immediately.

NOTICE

Do not ride the motorcycle with air in the brake line, or the ABS could malfunction.

- The ABS indicator light (LED) [A] may light if the tire pressure is incorrect, a non-recommended tire is installed, or the wheel is deformed. If the indicator light lights, remedy the problem and clear the service code.

⚠ WARNING

Use of non-recommended tires may cause malfunctioning of ABS and can lead to extended braking distance resulting in an accident causing serious injury or death. Always use recommended standard tires for this motorcycle.

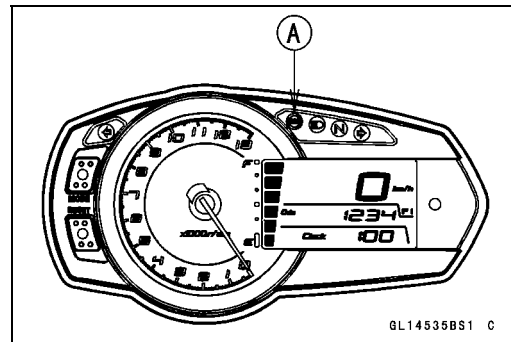

Anti-Lock Brake System (Equipped Models)

- The ABS indicator light (LED) may come on if the engine is run with the motorcycle on its stand and the transmission in gear. If the indicator light comes on, just turn the ignition switch OFF, then clear service code 42, which indicates a “Faulty front wheel rotation sensor”.
- When the ABS operates, the ABS makes noise and the rider feels the reaction force on the brake lever and brake pedal. This is a normal condition. It informs the rider that the ABS is operating normally.
- Service codes detected once by the ABS hydraulic unit will be memorized in the ABS hydraulic unit. Therefore, after maintenance work is finished, be sure to erase the service codes. Do not erase the service codes during troubleshooting. Wait until all the checks and repair work are finished to prevent duplication of previous service codes and unnecessary maintenance work.
- Before delivering the motorcycle to the customer, be sure to erase any service codes which might be stored in the ABS hydraulic unit. Using the self-diagnosis feature, make sure that the ABS indicator light (LED) lights. A fully charged battery is a must for conducting reliable self-diagnosis. Test run the motorcycle at a speed of more than 20 km/h (12 mph) to see that the ABS indicator light (LED) does not come on. Finally, test run the motorcycle at a speed of more than 30 km/h (20 mph) and brake suddenly to see that the motorcycle stops without loss of steering control and the ABS operates normally (The reaction force generated is felt in the brake lever and pedal.). This completes the final inspection.

ABS Troubleshooting Outline

When an abnormality in the system occurs, the ABS indicator light (LED) lights up to alert the rider. In addition, the nature of the fault is stored in the memory of the ABS hydraulic unit and when in the self-diagnosis mode, the service code [A] is indicated by the number of times the ABS indicator light (LED) blinks. The service codes stored in memory are not erased until the mode has been changed to the fault erase mode after the fault has been corrected. Therefore, after correcting the problem, always erase the service codes and then run the self-diagnosis program to confirm normal signal output. When, due to a malfunction, the ABS indicator light (LED) remains lit, get a thorough understanding of the background before starting the repair work. Ask the rider about the conditions [B] under which the problem occurred and try to determine the cause [C]. Do not rely solely on the ABS self-diagnosis function, use common sense; check the brakes for proper braking power, and brake fluid level, search for leaks, etc.

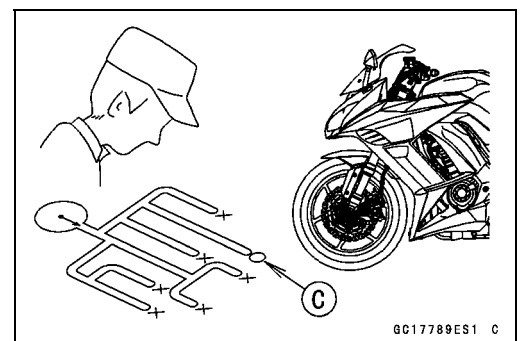
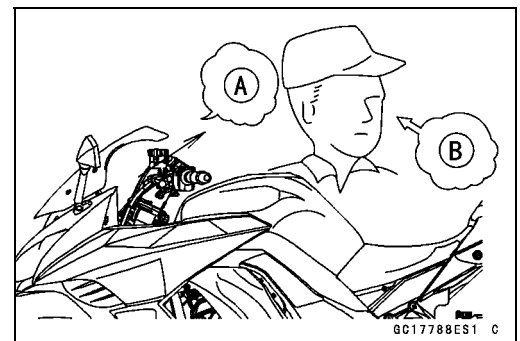

12-36 BRAKES

Anti-Lock Brake System (Equipped Models)

Even when the ABS is operating normally, the ABS indicator light (LED) may light up under the conditions listed below. Turn the ignition switch OFF to stop the indicator light. If the motorcycle runs without erasing the service code, the light may light up again.

- After continuous riding on a rough road.
- When the engine is started with the stand raised and the transmission engaged, and the rear wheel turns.
- When accelerating so abruptly that the front wheel leaves the ground.
- When the ABS has been subjected to strong electrical interference.
- When tire pressure is abnormal. Adjust tire pressure.
- When a tire different in size from the standard size is being used. Replace with standard size.
- When the wheel is deformed. Replace the wheel.

Much of the ABS troubleshooting work consists of confirming continuity of the wiring. The ABS parts are assembled and adjusted by the manufacturer, so there is no need to disassemble or repair them. Replace the ABS hydraulic unit.

The basic troubleshooting procedures are listed below.

- Carry out pre-diagnosis inspections as a preliminary inspection.
- Determine the fault using the self-diagnosis function.
- Check wiring and connections from the ABS hydraulic unit connector to the suspected faulty ABS part, using the hand tester.

Special Tool - Hand Tester: 57001-1394

- Visually inspect the wiring for signs of burning or fraying.
- ★ If any wiring is poor, replace the damaged wiring.
- Pull each connector [A] apart and inspect it for corrosion, dirt and damage.
- ★ If the connector is corroded or dirty, clean it carefully. If it is damaged, replace it.
- Check the wiring for continuity.
- Use the wiring diagram to find the ends of the lead which is suspected of being a problem.
- Connect the hand tester between the ends of the leads.

Special Tool - Hand Tester: 57001-1394

- Set the tester to the $\times 1 \Omega$ range, and read the tester.
- ★ If the tester does not read 0Ω , the lead is defective. Replace the main harness [B] if necessary.
- Narrow down suspicious parts and close in on the faulty ABS part by repeating the continuity tests.
- ★ If no abnormality is found in the wiring or connectors, the ABS parts are the next likely suspects. Check each part one by one.
- ★ If an abnormality is found, replace the affected ABS part.

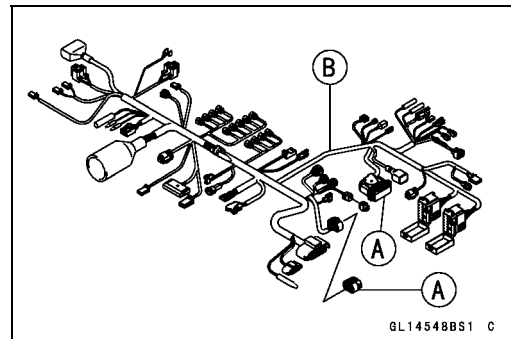

Anti-Lock Brake System (Equipped Models)

ABS Diagnosis Flow Chart

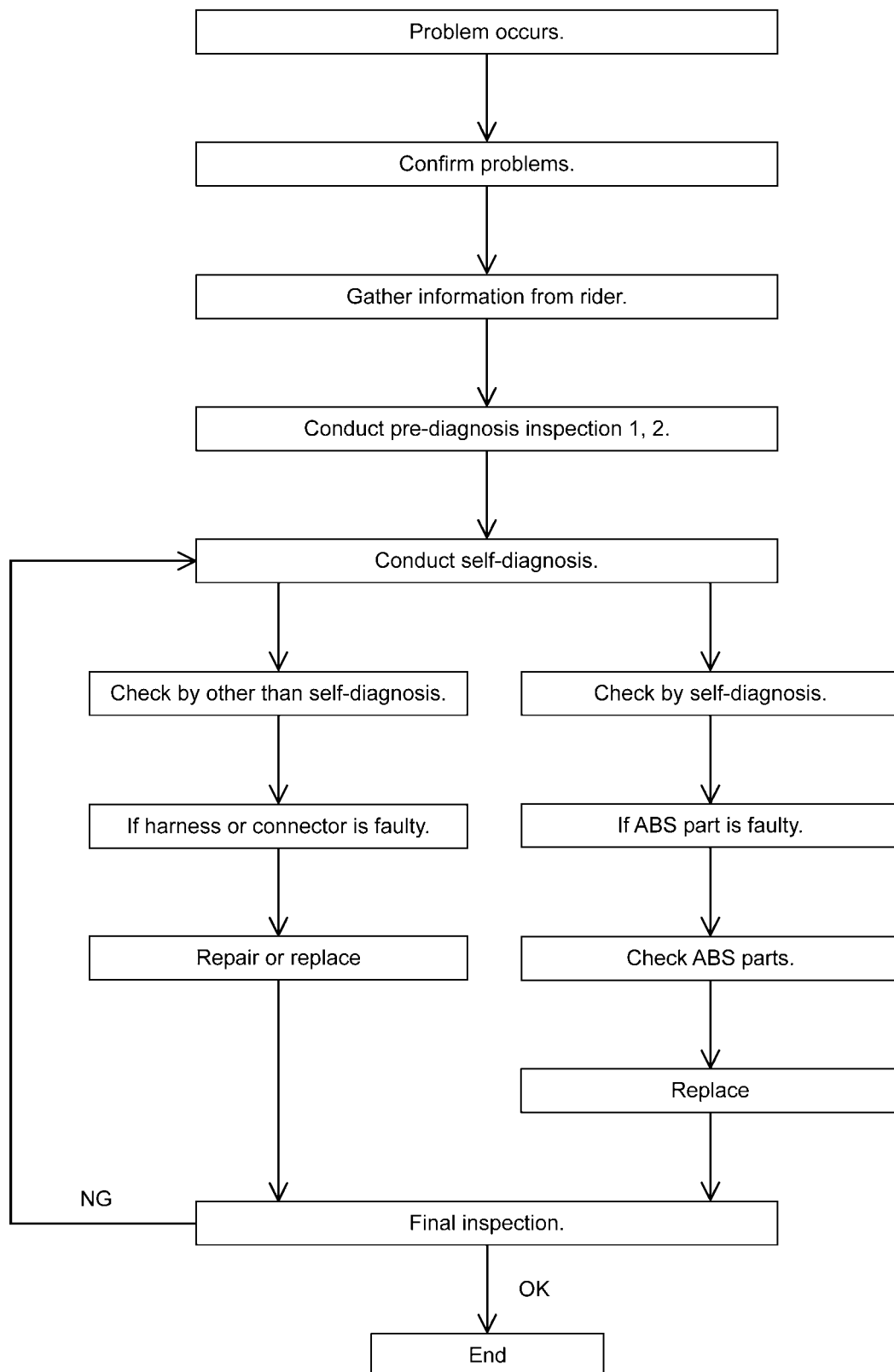

12-38 BRAKES

Anti-Lock Brake System (Equipped Models)

Inquiries to Rider

- Each rider reacts to problems in different ways, so it is important to confirm what kind of condition the rider is dissatisfied with.
- Try to find out exactly what problem occurs under exactly what conditions by asking the rider; knowing this information may help you reproduce the problem in the shop.
- The diagnosis sheet will help prevent you from overlooking any keys, so always use it.

Sample Diagnosis Sheet

Rider name:				Registration No. (license plate No.):			
Year of initial registration:				Model:			
Engine No.:				Frame No.:			
Date problem occurred:				Frequency:			
Weather:				Mileage:			
Phenomenon	<input type="checkbox"/> Brake lever vibration or noise	<input type="checkbox"/> Indicator light blinks	<input type="checkbox"/> Braking distance too long	<input type="checkbox"/> Abnormal brake lever movement	<input type="checkbox"/> ABS not working	<input type="checkbox"/> ABS works but indicator light doesn't light up	<input type="checkbox"/> ABS operating too frequently
	<input type="checkbox"/> Pedal vibration or noise	<input type="checkbox"/> Indicator light remains lit up		<input type="checkbox"/> Abnormal pedal movement			
Engine conditions at problem	<input type="checkbox"/> At start-up		<input type="checkbox"/> After starting		<input type="checkbox"/> At 5 000 r/min (rpm) or more		
Road conditions	<input type="checkbox"/> Slippery road (<input type="checkbox"/> snow, <input type="checkbox"/> gravel, <input type="checkbox"/> other) <input type="checkbox"/> Rough surface <input type="checkbox"/> Other						
Driving conditions	<input type="checkbox"/> High-speed cornering <input type="checkbox"/> Driving 10 km/h (6 mph) or above <input type="checkbox"/> Driving below 10 km/h (6 mph) <input type="checkbox"/> When stopping <input type="checkbox"/> When turning						
Brake application	<input type="checkbox"/> Gradual <input type="checkbox"/> Abrupt						
Other conditions	<input type="checkbox"/> Large brake lever stroke <input type="checkbox"/> Large pedal stroke						

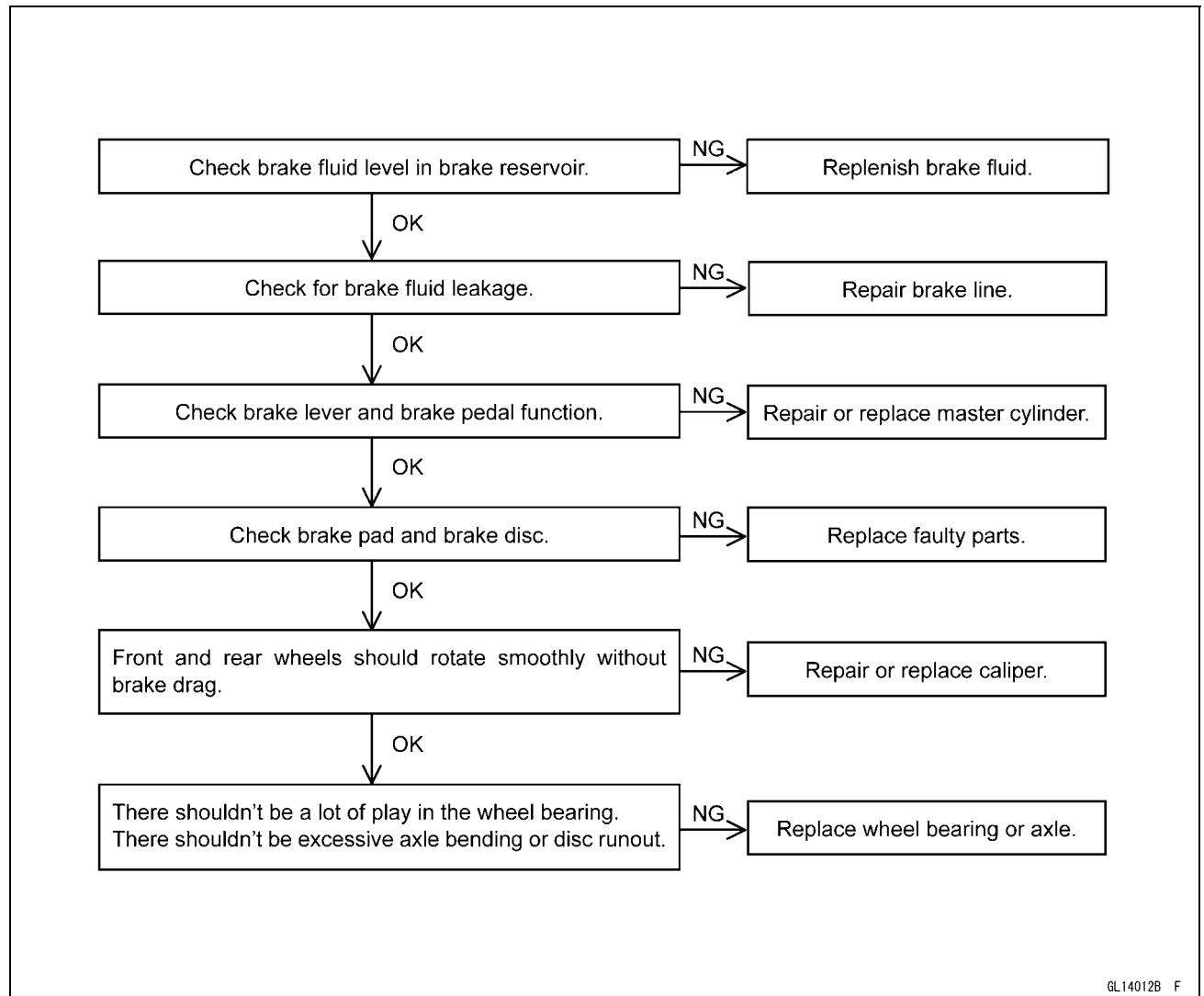
Anti-Lock Brake System (Equipped Models)**Pre-Diagnosis Inspection 1**

12-40 BRAKES

Anti-Lock Brake System (Equipped Models)

Pre-Diagnosis Inspection 2

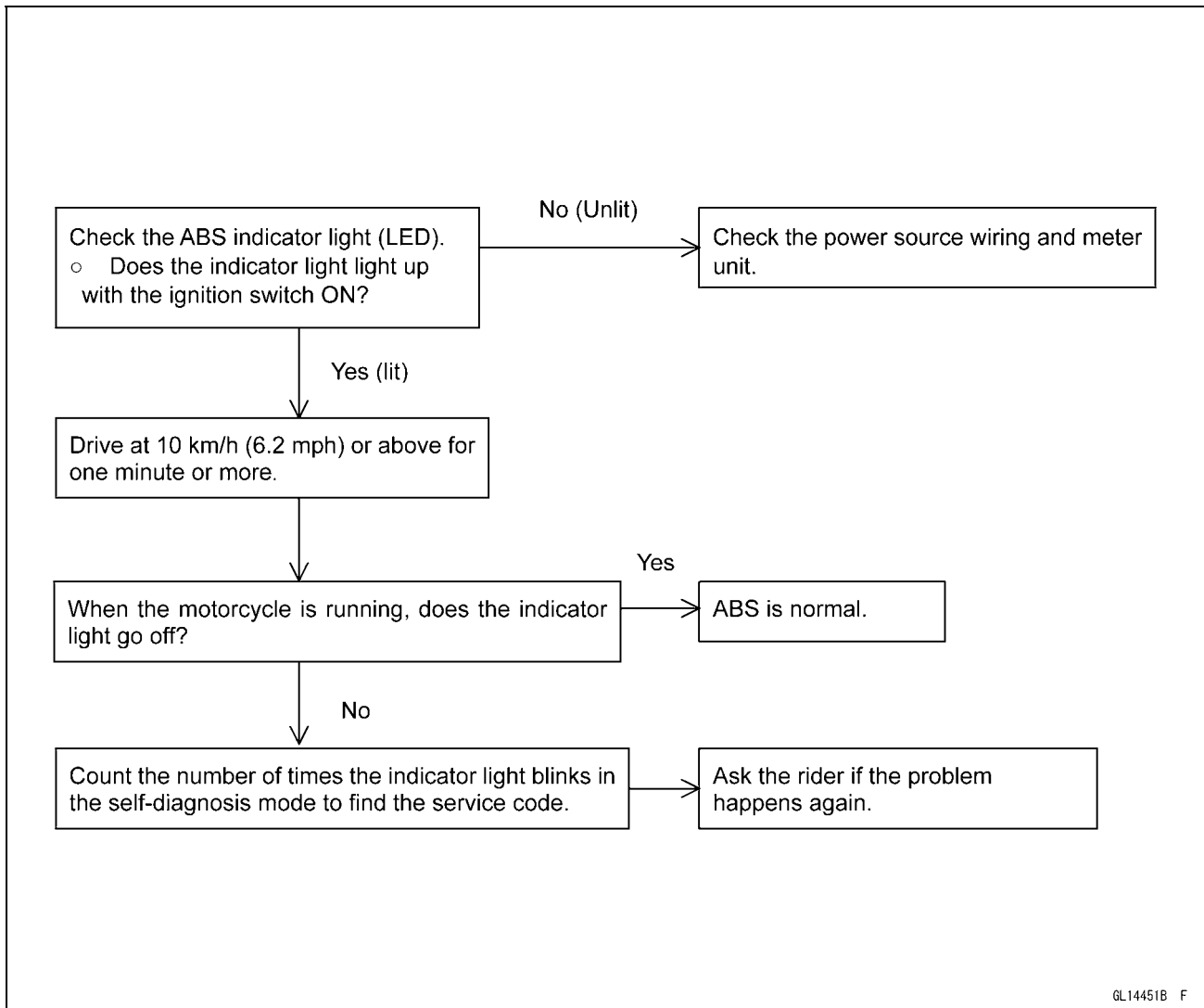

Self-diagnosis Outline

When the indicator light has blinked or come on, the ABS hydraulic unit memorizes and stores the service code (17 codes including “Normal Code”) for the service person to troubleshoot easily. The service code memory is powered directly by the battery and cannot be canceled by the ignition switch.

The ABS hydraulic unit can memorize up to all service codes (17 codes). Further service codes are memorized after erasing the preceding all service codes (17 codes). If there is no fault, only the start code 12 is shown, indicating that “The ABS is normal”.

Self-diagnosis Procedures

○When a problem occurs with the ABS system, the ABS indicator light (LED) [A] lights.

NOTE

- Use a fully charged battery when conducting self-diagnosis. Otherwise, the light blinks very slowly or doesn't blink.
- The motorcycle is stopped.
- Keep the self-diagnosis terminal grounded during self-diagnosis, with an auxiliary lead.

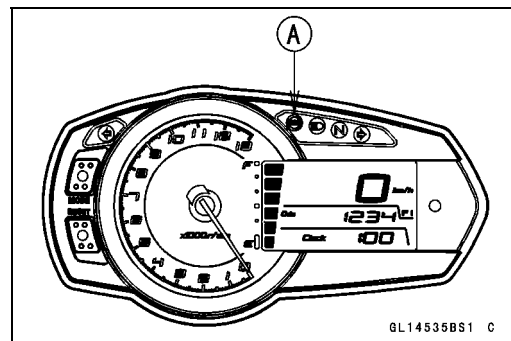

Anti-Lock Brake System (Equipped Models)

- Remove the rear seat (see Rear Seat Removal in the Frame chapter).
- Turn on the ignition switch.
- Ground the self-diagnosis terminal [A] (Gray) to the battery (-) terminal, using a suitable lead.
- Count the blinks of the light to read the service code. Keep the auxiliary lead ground until you finish reading the service code.

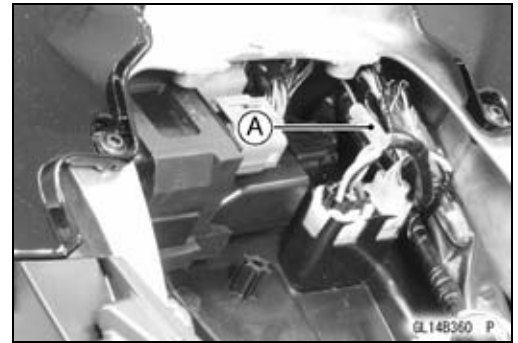

Service Code Clearing Procedures

- Start the service code erase mode with the following procedure.
- The erase mode starts when the ABS self-diagnosis terminal is disconnected from the ground terminal after starting the self-diagnosis mode.
- The service code can be erased by grounding and ungrounding (each time for at least one second) the ABS self-diagnosis terminal three times within about 12.5 seconds after starting the erase mode.
- The ABS indicator light (LED) remains lit during the erase mode.
- After erasing, the ABS indicator light (LED) blinks and lights.
- Once erasing is finished, enter the self-diagnosis mode again to confirm that the service codes have been erased. If the ABS has been reset and all codes have been erased, only start code 12 will be shown.

12-42 BRAKES

Anti-Lock Brake System (Equipped Models)

Erasing of Service Code

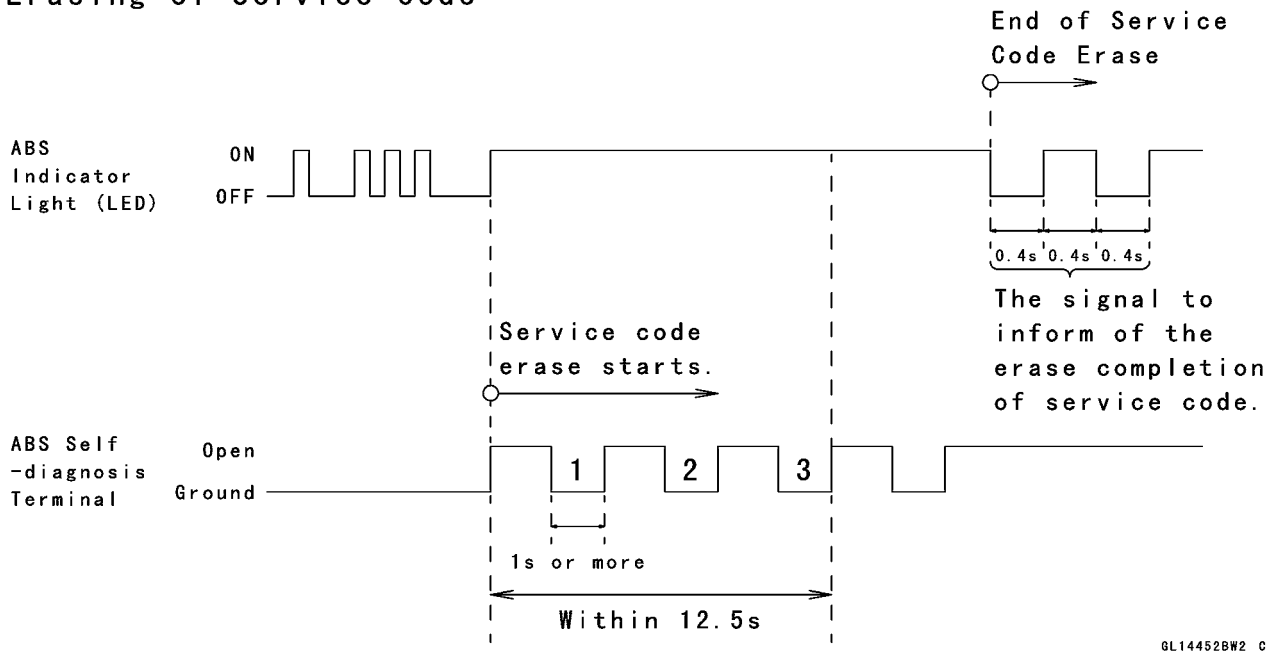

Anti-Lock Brake System (Equipped Models)

Self-diagnosis Flow Chart

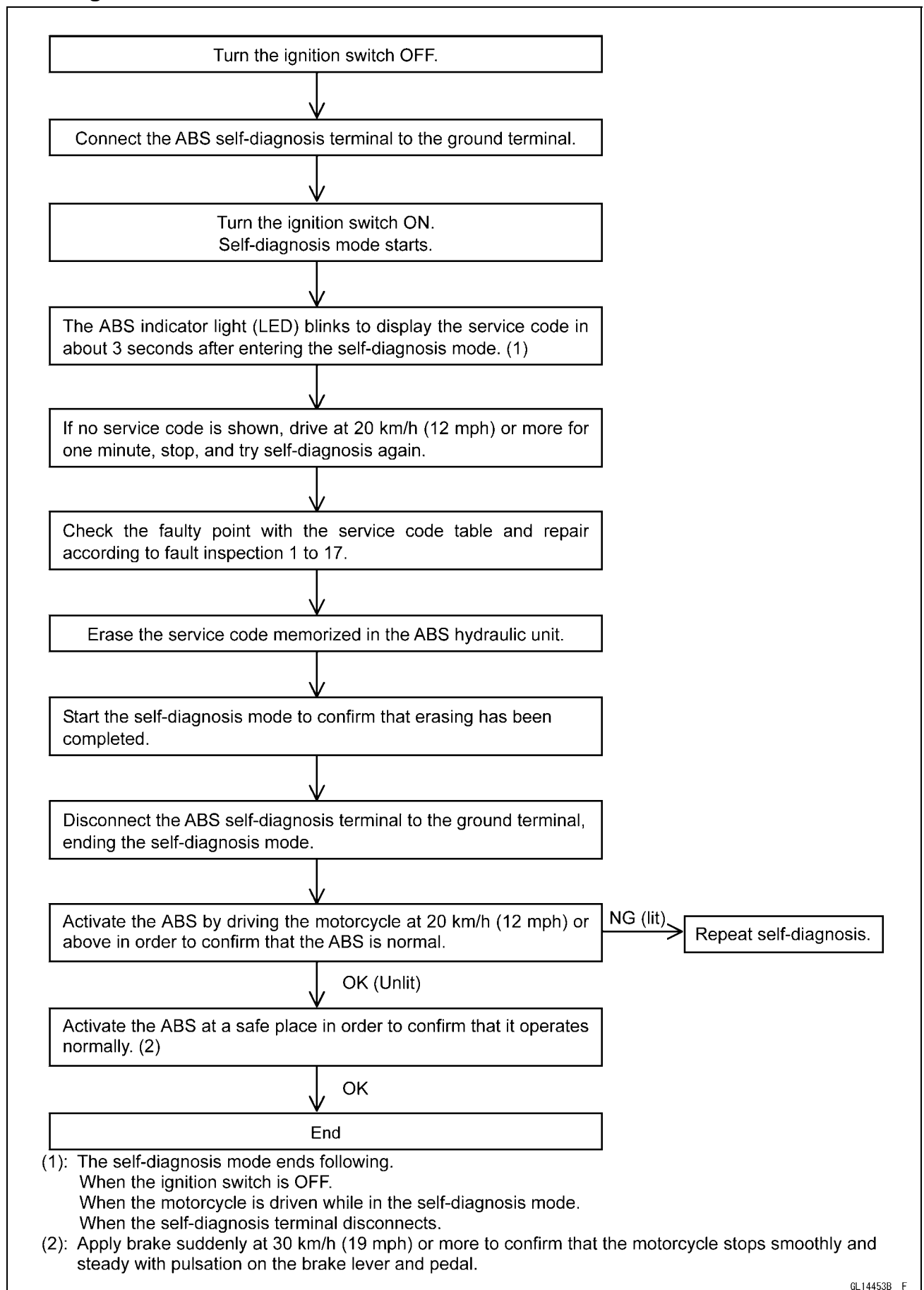

12-44 BRAKES

Anti-Lock Brake System (Equipped Models)

How to Read Service Codes

- Service codes are shown by a series of long and short blinks of the ABS indicator light (LED) as shown below.
- Read 10th digit and unit digit as the ABS indicator light (LED) blinks.
- When there are a number of faults, a maximum of all service codes (17 codes) can be stored and the display will begin starting from the small number code entered.
- For the display pattern, first the smallest number code is shown, next up to all service codes (17 codes) starting with the last one stored, then the display is repeated from the smallest number code once again.

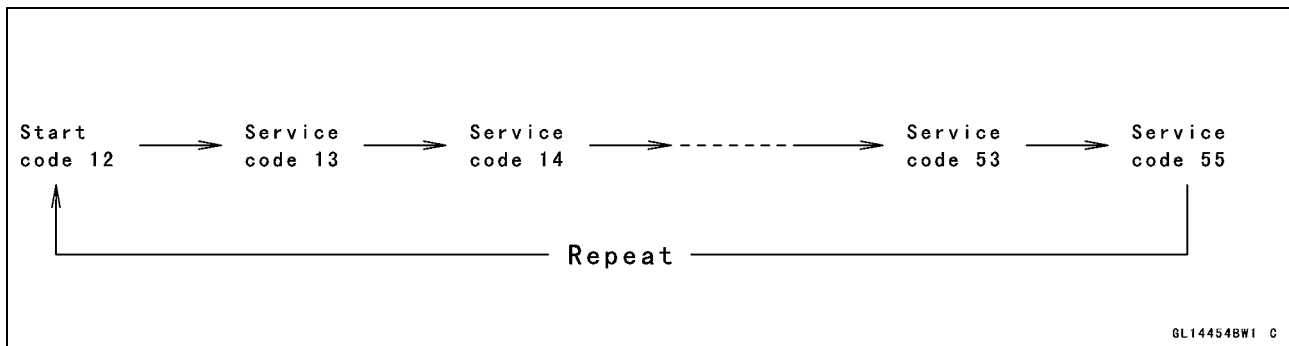

○If there is no fault, the ABS indicator light (LED) lights as shown in the figure.

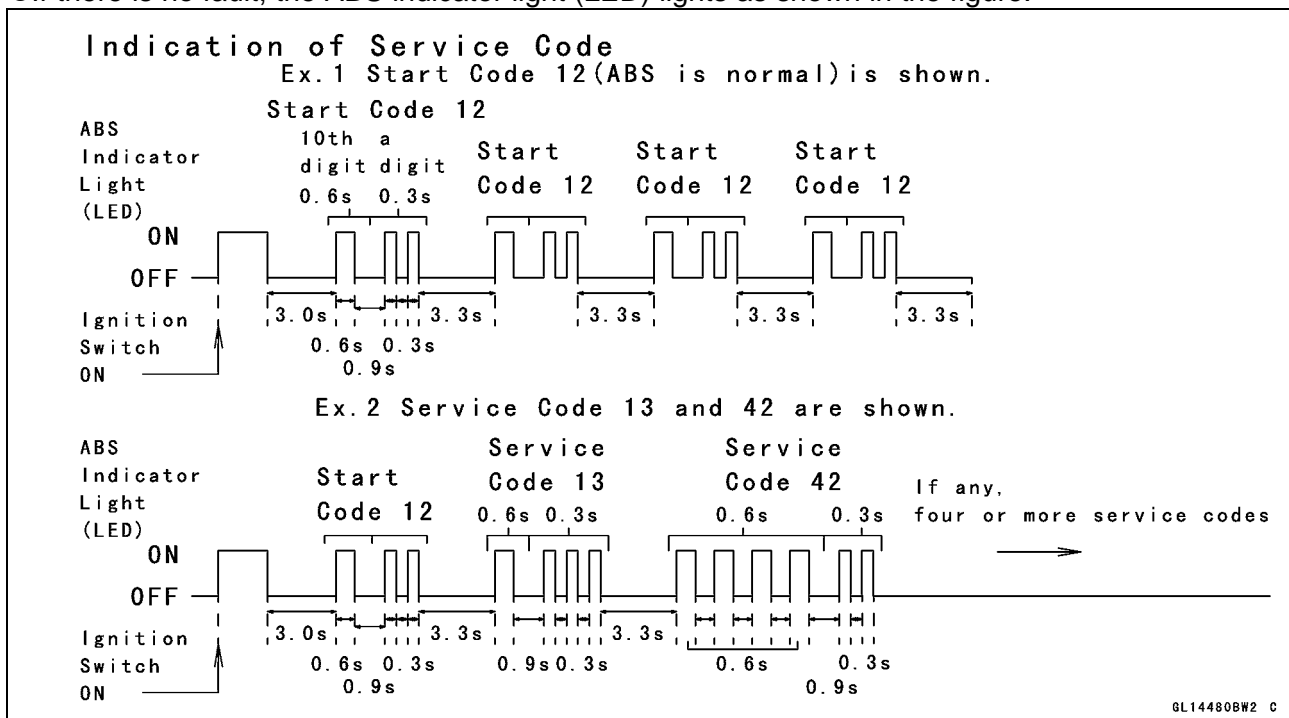











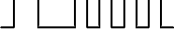

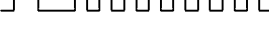
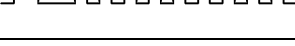

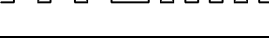
How to Erase Service Codes

- Even if the ignition switch is turned OFF, the battery or the ABS hydraulic unit are disconnected, all service codes remain in the ABS hydraulic unit.
- Refer to the Service Code Clearing Procedure for the service code erasure.

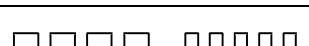
Anti-Lock Brake System (Equipped Models)

Service Code Table

Service Code	ABS Indicator Light (LED)	Problems	Light State
11	 ON OFF	Rise in heat of solenoid coil by ABS continuousness operation	ON
12		Start code (not fault)	After starts, turn off
13		Rear inlet solenoid valve trouble (shorted or open, stuck valve)	ON
14		Rear outlet solenoid valve trouble (shorted or open, stuck valve)	ON
17		Front inlet solenoid valve trouble (shorted or open, stuck valve)	ON
18		Front outlet solenoid valve trouble (shorted or open, stuck valve)	ON
19		ABS solenoid valve relay trouble (wiring shorted or open, stuck relay)	ON
25		Front, rear tire abnormal (substandard tire, deformation wheel, sensor rotor teeth number wrong)	ON
35		ABS motor relay trouble (wiring shorted, open or lock, stuck relay)	ON
42		Front wheel rotation sensor signal abnormal (sensor or rotor missing, too large clearance, rotor tooth worn or missing)	ON
43		Front wheel rotation sensor wiring abnormal (wiring shorted or open)	ON
44		Rear wheel rotation sensor signal abnormal (sensor or rotor missing, too large clearance, rotor tooth worn or missing)	ON
45		Rear wheel rotation sensor wiring abnormal (wiring shorted or open)	ON
52		Power supply voltage abnormal (low-voltage)	ON
53		Power supply voltage abnormal (low-voltage)	ON
55		ECU trouble (ECU operation abnormal)	ON
93		Wheel rotation sensor signal abnormal (too high speed, special road running, substandard tire)	ON

12-46 BRAKES

Anti-Lock Brake System (Equipped Models)

ABS Indicator Light (LED) Inspection

○ In this model, the ABS indicator light (LED) [A] goes on or blinks by the control of the ABS hydraulic unit.

- Turn the ignition switch ON.
- ★ If the ABS indicator light (LED) lights, it is normal.
- ★ If the ABS indicator light (LED) does not light, refer to the Meter Unit Inspection in the Electrical System chapter.

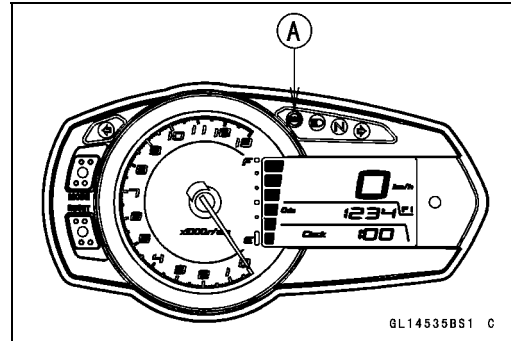

- ★ If the meter is good, check the wiring continuity of the BK/W lead in the main harness.

Special Tool - Hand Tester: 57001-1394

Wiring Continuity Inspection

Meter Connector [A] ← → ABS Hydraulic Unit Connector [B]

BK/W Lead [C]

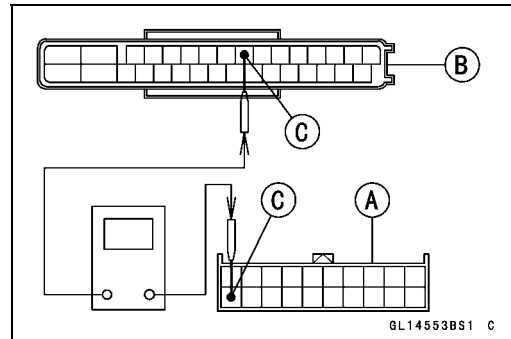

- ★ If there is not the continuity in the lead, replace or repair the main harness.
- ★ If there is the continuity in the lead, replace the ABS hydraulic unit.

Solenoid Coil Temperature Abnormal [High-Temperature] (Service Code 11)

○ When the temperature of the solenoid coil rises more than a prescribed value by the ABS continuousness operation, this service code is detected. Therefore, check it after leaving the motor cycle for tens of minutes or more.

- Recheck the service code indication; erase the service code, perform the pre-diagnosis inspection 1 and 2, and retrieve the service code.
- ★ If the ABS indicator light (LED) [A] lights, the ABS hydraulic unit has trouble. Replace the ABS hydraulic unit.
- ★ If the ABS indicator light (LED) does not light, ABS system is normal (service code is not stored; temporary failure.).

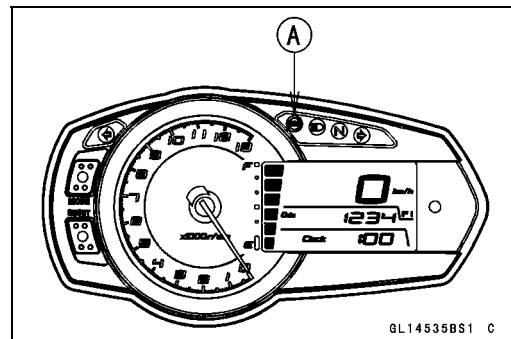

Solenoid Valve Inspection (Service Code 13, 14, 17, 18)

- Recheck the service code indication; erase the service code, perform the pre-diagnosis inspection 1 and 2, and retrieve the service code.
- ★ If the ABS indicator light (LED) [A] light, the solenoid valve in the ABS hydraulic unit has trouble. Replace the ABS hydraulic unit.
- ★ If the ABS indicator light (LED) does not light, ABS system is normal (service code is not stored; temporary failure.).

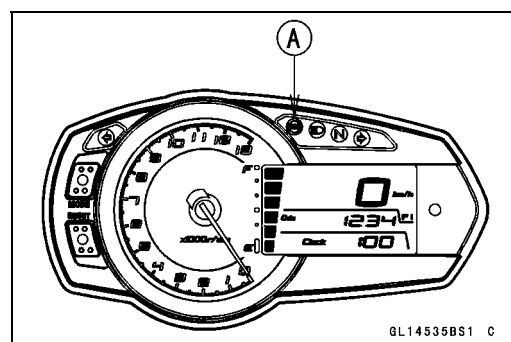

Anti-Lock Brake System (Equipped Models)

ABS Solenoid Valve Relay Inspection (Service Code 19)

- Remove:
 - Front Seat (see Front Seat Removal in the Frame chapter)
- Check the ABS solenoid valve relay fuse (20 A) [A] (see Fuse Inspection in the Electrical System chapter).

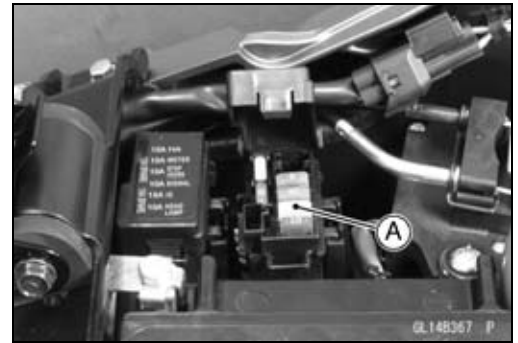

- ★ If the fuse is good, check the wiring continuity that relates to the LG lead in the main harness referring to the ABS System Wiring Diagram.

Special Tool - Hand Tester: 57001-1394

Wiring Continuity Inspection

ABS Hydraulic Unit
 Connector [A] ↔ Fuse Box Terminal [B]
 LG Lead [C]

- ★ If there is not the continuity in the lead, replace or repair the main harness.
- ★ If there is the continuity in the lead, go to next step.

- Recheck the service code indication; erase the service code, perform the pre-diagnosis inspection 1 and 2, and retrieve the service code.
- ★ If the ABS indicator light (LED) [A] lights, the ABS hydraulic unit has trouble. Replace the ABS hydraulic unit.
- ★ If the ABS indicator light (LED) does not light, ABS system is normal (service code is not stored; temporary failure.).

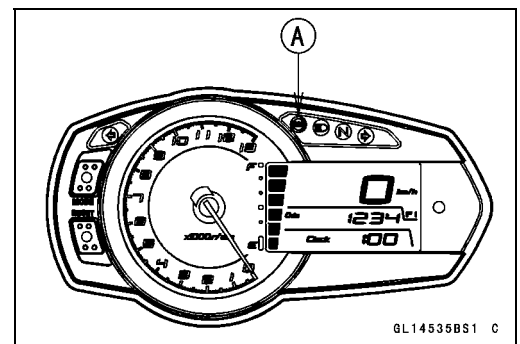
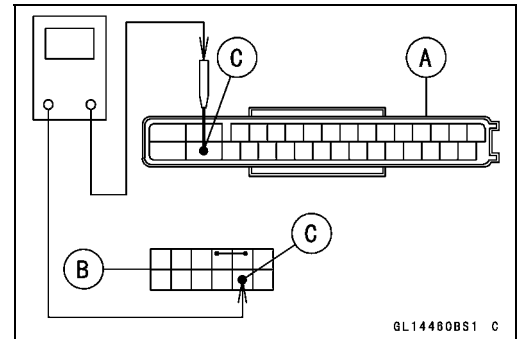

Front, Rear Wheel Rotation Difference Abnormal (Service Code 25)

- Check the following and correct the faulty part.
 - Incorrect Tire Pressure
 - Tires not recommended for the motorcycle were installed (incorrect tire size).
 - Deformation of Wheel or Tire
 - Missing Teeth and Clogging with Foreign Matter of Sensor Rotor (see Wheel Rotation Sensor Inspection)
- ★ If the all parts correct, recheck the service code indication; erase the service code, perform the pre-diagnosis inspection 1 and 2, and retrieve the service code.

12-48 BRAKES

Anti-Lock Brake System (Equipped Models)

- ★ If the ABS indicator light (LED) [A] lights, the ABS hydraulic unit has trouble. Replace the ABS hydraulic unit.
- ★ If the ABS indicator light (LED) does not light, ABS system is normal (service code is not stored; temporary failure.).

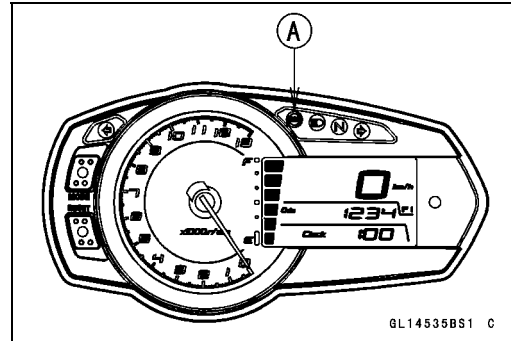

ABS Motor Relay Inspection (Service Code 35)

- Remove:
 - Front Seat (see Front Seat Removal in the Frame chapter)
- Check the ABS motor relay fuse (30 A) [A] (see Fuse Inspection in the Electrical System chapter).



- ★ If the fuse is good, check the wiring continuity that relates to the R lead in the main harness referring to the ABS System Wiring Diagram.

Special Tool - Hand Tester 57001-1394

Wiring Continuity Inspection

ABS Hydraulic Unit
Connector [A] ↔ Fuse Box Terminal [B]
R Lead [C]

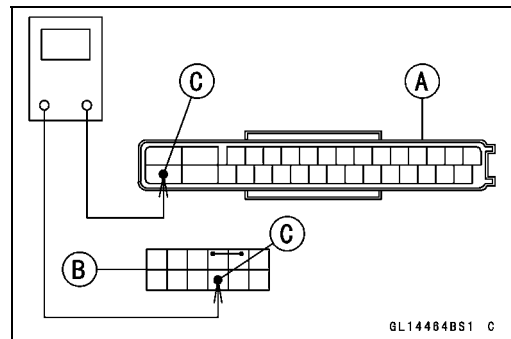

- ★ If there is not the continuity in the lead, replace or repair the main harness.
- ★ If there is the continuity in the lead, go to next step.
- Recheck the service code indication; erase the service code, perform the pre-diagnosis inspection 1 and 2, and retrieve the service code.
- ★ If the ABS indicator light (LED) [A] lights, the ABS hydraulic unit has trouble. Replace the ABS hydraulic unit.
- ★ If the ABS indicator light (LED) does not light, ABS system is normal (service code is not stored; temporary failure.).

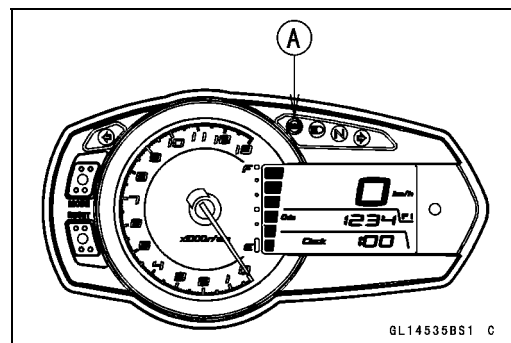

Front Wheel Rotation Sensor Signal Abnormal (Service Code 42)

- Measure the air gap between the front wheel rotation sensor and sensor rotor (see Wheel Rotation Sensor Air Gap Inspection).
- Check the front wheel rotation sensor (see Wheel Rotation Sensor Inspection).
- ★ If both inspections are good, go to next step.

Anti-Lock Brake System (Equipped Models)

- Check that there is iron or other magnetic deposits between the sensor [A] and sensor rotor [B], and the sensor rotor slots for obstructions.
 - Check the installation condition of the sensor for looseness.
 - Check the sensor rotor tip for deformation or damage (e.g., chipped sensor rotor teeth).
 - ★ If the sensor rotor is in bad condition, remove the any deposits. Install the proper part or replace faulty part.
 - ★ If the all items are good, go to next step.
-
- Recheck the service code indication; erase the service code, perform the pre-diagnosis inspection 1 and 2, and retrieve the service code.
 - ★ If the ABS indicator light (LED) [A] lights, the ABS hydraulic unit has trouble. Replace the ABS hydraulic unit.
 - ★ If the ABS indicator light (LED) does not light, ABS system is normal (service code is not stored; temporary failure.).

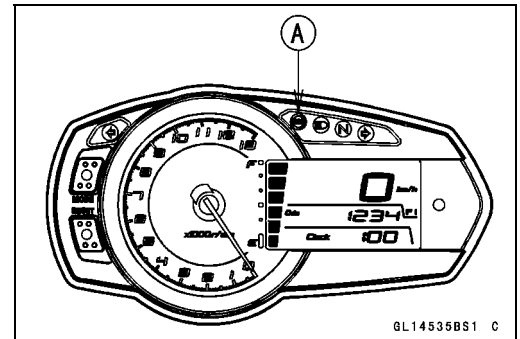
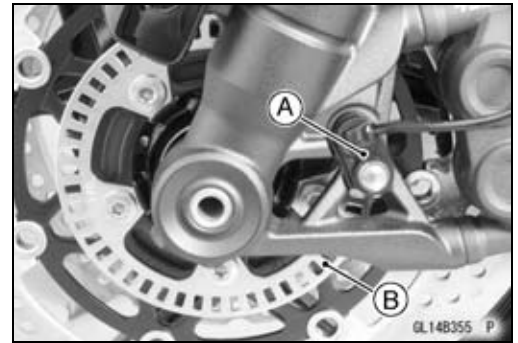

Front Wheel Rotation Sensor Wiring Inspection (Service Code 43)

- Disconnect:
 - ABS Hydraulic Unit Connector (see ABS Hydraulic Unit Removal)
 - Front Wheel Rotation Sensor Connector (see Front Wheel Rotation Sensor Removal)
- Check the wiring continuity of the G lead and BK/R lead.

Special Tool - Hand Tester 57001-1394

Wiring Continuity Inspection

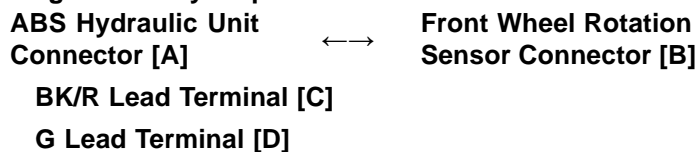

- ★ If there is not the continuity in the lead, replace or repair the main harness.
- ★ If the wiring is good, go to next step.

- Recheck the service code indication; erase the service code, perform the pre-diagnosis inspection 1 and 2, and retrieve the service code.
- ★ If the ABS indicator light (LED) [A] lights, replace the front wheel rotation sensor (see Front Wheel Rotation Sensor Removal).
- ★ Still, when it is not good, replace the ABS hydraulic unit.
- ★ If the ABS indicator light (LED) does not light, ABS system is normal (service code is not stored; temporary failure.).

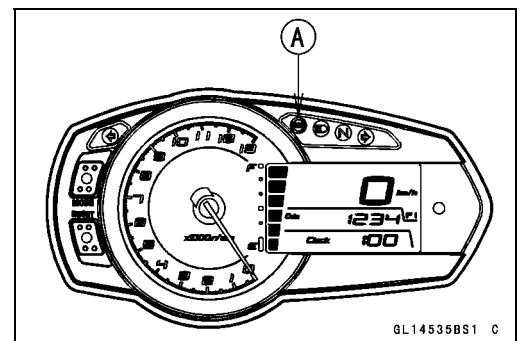
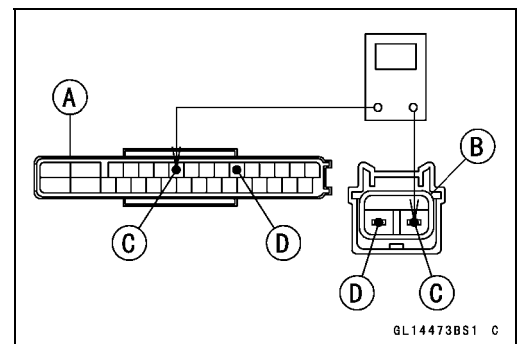

12-50 BRAKES

Anti-Lock Brake System (Equipped Models)

Rear Wheel Rotation Sensor Signal Abnormal (Service Code 44)

- Measure the air gap between the rear wheel rotation sensor and sensor rotor (see Wheel Rotation Sensor Air Gap Inspection).
- Check the rear wheel rotation sensor (see Rear Wheel Rotation Sensor Inspection).
- ★ If both inspections are good, go to next step.
- Check that there is iron or other magnetic deposits between the sensor [A] and sensor rotor [B], and the sensor rotor slots for obstructions.
- Check the installation condition of the sensor for looseness.
- Check the sensor rotor tip for deformation or damage (e.g., chipped sensor rotor teeth).
- ★ If the sensor rotor in bad condition, remove the any deposits. Install the proper part or replace faulty part.
- ★ If the all items are good, go to next step.
- Recheck the service code indication; erase the service code, perform the pre-diagnosis inspection 1 and 2, and retrieve the service code.
- ★ If the ABS indicator light (LED) [A] lights, the ABS hydraulic unit has trouble. Replace the ABS hydraulic unit.
- ★ If the ABS indicator light (LED) does not light, ABS system is normal (service code is not stored; temporary failure.).

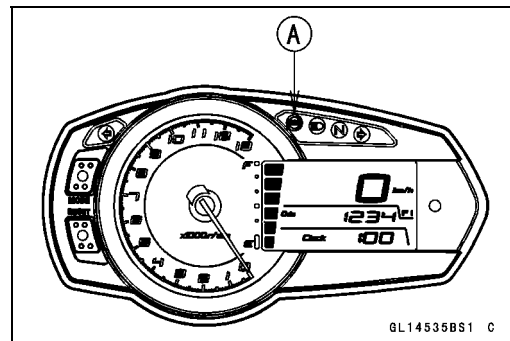
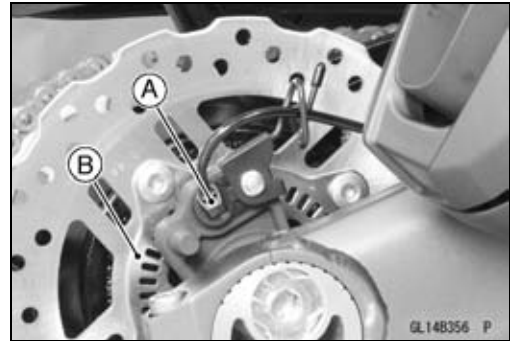

Rear Wheel Rotation Sensor Wiring Inspection (Service Code 45)

- Disconnect:
 - ABS Hydraulic Unit Connector (see ABS Hydraulic Unit Removal)
 - Rear Wheel Rotation Sensor Connector (see Rear Wheel Rotation Sensor Removal)
- Check the wiring continuity of the BK lead and BR/BK lead.

Special Tool - Hand Tester 57001-1394

Wiring Continuity Inspection

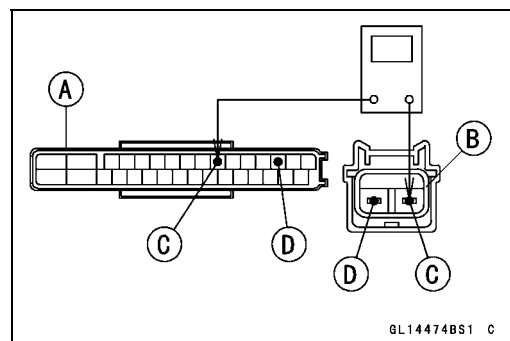
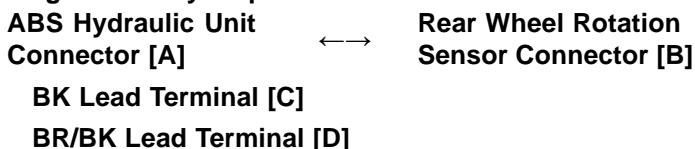

- ★ If there is not the continuity in the lead, replace or repair the main harness.
- ★ If the wiring is good, go to next step.

Anti-Lock Brake System (Equipped Models)

- Recheck the service code indication; erase the service code, perform the pre-diagnosis inspection 1 and 2, and retrieve the service code.
- ★ If the ABS indicator light (LED) [A] lights, replace the rear wheel rotation sensor (see Rear Wheel Rotation Sensor Removal).
- ★ Still, when it is not good, replace the ABS hydraulic unit.
- ★ If the ABS indicator light (LED) does not light, ABS system is normal (service code is not stored; temporary failure.).

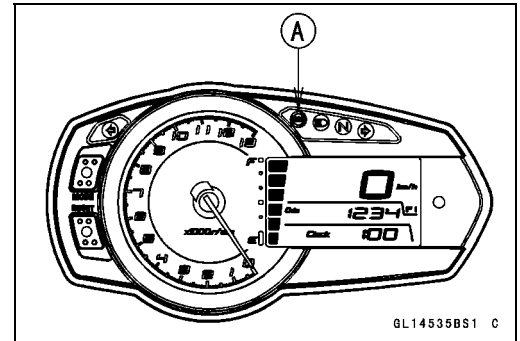

Power Supply Voltage Abnormal (Low-Voltage) (Service Code 52)

- Check:
 - Battery Condition (see Charging Condition Inspection in the Electrical System chapter)
 - Charging Voltage (see Charging Voltage Inspection in the Electrical System chapter)
- ★ If the battery and charging voltage are good condition, go to next step.
- Recheck the service code indication; erase the service code, perform the pre-diagnosis inspection 1 and 2, and retrieve the service code.
- ★ If the ABS indicator light (LED) [A] lights, the ABS hydraulic unit has trouble. Replace the ABS hydraulic unit.
- ★ If the ABS indicator light (LED) does not light, ABS system is normal (service code is not stored; temporary failure.).

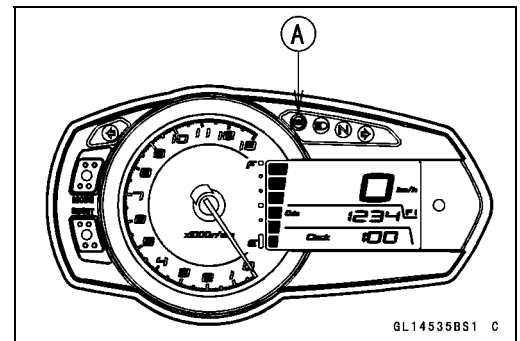

Power Supply Voltage Abnormal (Over-Voltage) (Service Code 53)

- Check the charging voltage (see Charging Voltage Inspection in the Electrical System chapter).
- ★ If the charging voltage is good, go to next step.
- Recheck the service code indication; erase the service code, perform the pre-diagnosis inspection 1 and 2, and retrieve the service code.
- ★ If the ABS indicator light (LED) [A] lights, the ABS hydraulic unit has trouble. Replace the ABS hydraulic unit.
- ★ If the ABS indicator light (LED) does not light, ABS system is normal (service code is not stored; temporary failure.).

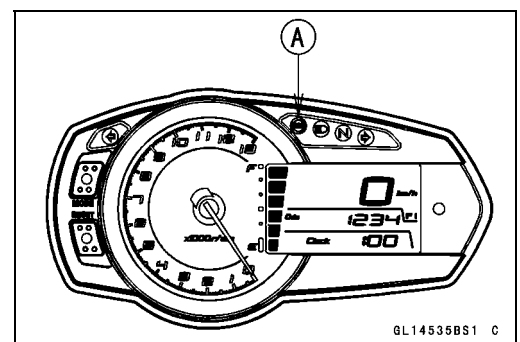

12-52 BRAKES

Anti-Lock Brake System (Equipped Models)

ECU Inspection (Service Code 55)

- Recheck the service code indication; erase the service code, perform the pre-diagnosis inspection 1 and 2, and retrieve the service code.
- ★ If the ABS indicator light (LED) [A] lights, the ABS hydraulic unit has trouble. Replace the ABS hydraulic unit.
- ★ If the ABS indicator light (LED) does not light, ABS system is normal (service code is not stored; temporary failure.).

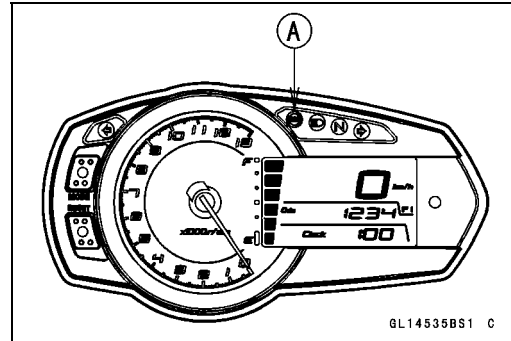

Wheel Rotation Sensor Signal Abnormal [Too High Speed] (Service Code 93)

- When the wheel rotation sensor signal detects 340 km/h or more at a motor cycle speed of 264 km/h or more, this service code is detected. Therefore, this service code might be detected by a special operation condition or using the substandard tire.
- Recheck the service code indication; erase the service code, perform the pre-diagnosis inspection 1 and 2, and retrieve the service code.
- ★ If the ABS indicator light (LED) [A] lights, the ABS hydraulic unit has trouble. Replace the ABS hydraulic unit.
- ★ If the ABS indicator light (LED) does not light, ABS system is normal (service code is not stored; temporary failure.).

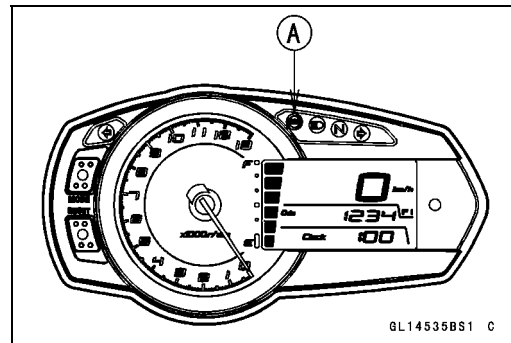

ABS Hydraulic Unit Removal

NOTICE

The ABS hydraulic unit [A] has been adjusted and set with precision at the factory. Therefore, it should be handled carefully, never struck sharply, as with a hammer, or allowed to fall on a hard surface.
Be careful not to get water or mud on the ABS hydraulic unit.

- Drain the brake fluid from the front and rear brake lines.
- Drain the brake fluid through the bleed valve by pumping the brake lever and pedal.



Anti-Lock Brake System (Equipped Models)

- Remove:
 - Battery Case (see Battery Case Removal in the Frame chapter)
 - Brake Hose (see Brake Hose Replacement in the Periodic maintenance chapter)
- Clean the ABS hydraulic unit.

NOTICE

Clean all fittings on the ABS hydraulic unit and the rear master cylinder because dirt around the banjo bolts could contaminate the brake fluid in the line during removal/installation.

Spread over a shop towel around the ABS hydraulic unit before removing the brake line so that brake fluid does not leak on the parts.

- Open the clamp [A].
- Disconnect the regulator/rectifier connector [B].

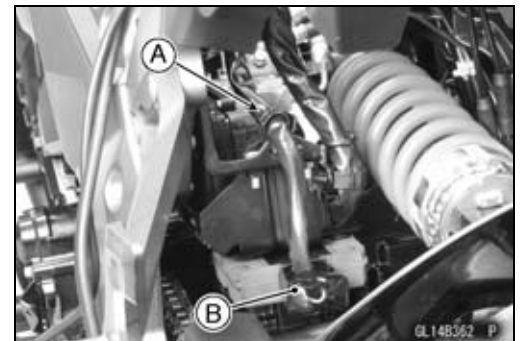

- Remove the bolts [A].
- Pull up the ABS hydraulic unit [B].

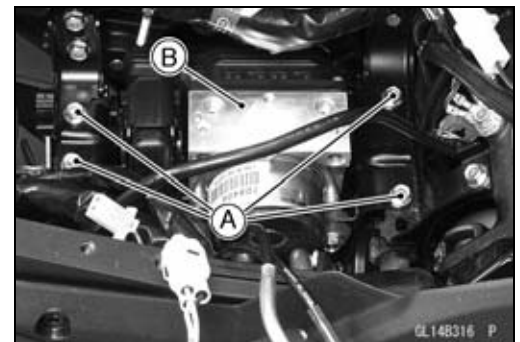

- While pushing the stopper [A], unlock the connector lock [B] upward.
- Disconnect the connector [C].

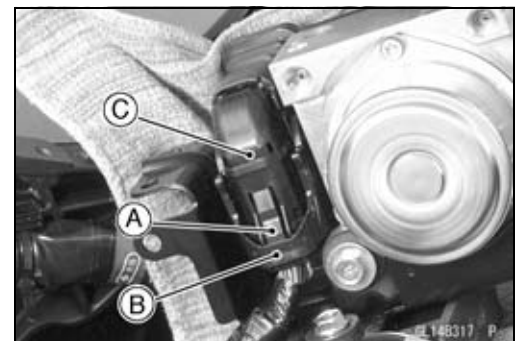

12-54 BRAKES

Anti-Lock Brake System (Equipped Models)

- Remove:
 - Bolts [A]
 - ABS Hydraulic Unit [B]

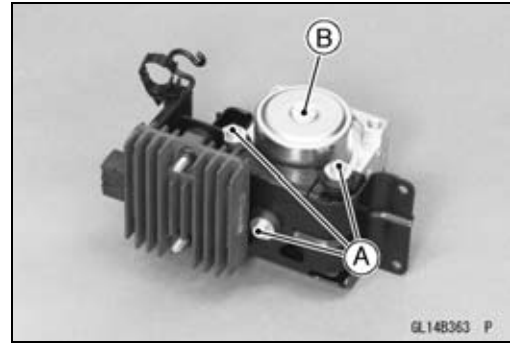

NOTICE

The ABS hydraulic unit [A] has been adjusted and set with precision at the factory. Do not try to disassemble and repair the ABS hydraulic unit.

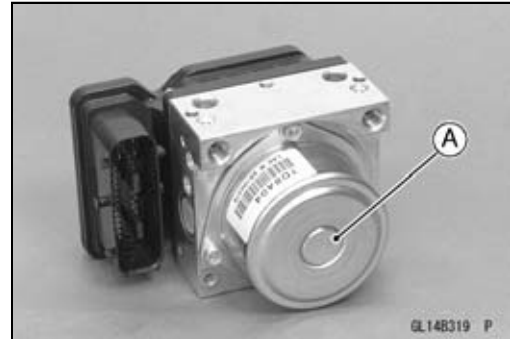

ABS Hydraulic Unit Installation

- Install the ABS hydraulic unit to the bracket.

NOTICE

Brake fluid quickly ruins painted plastic surfaces; any spilled fluid should be completely washed away immediately.

- Run the lead correctly, and connect the connector [A] securely.
- Lock the connector lock [B] as shown in the figure.
- Install the brake hoses correctly (see Brake Hose Replacement in the Periodic Maintenance chapter).
- Bleed the brake line (see Brake Line Bleeding).
- Check the brake for good braking power, no brake drag, and no fluid leakage.
- Install the removed parts (see appropriate chapters).

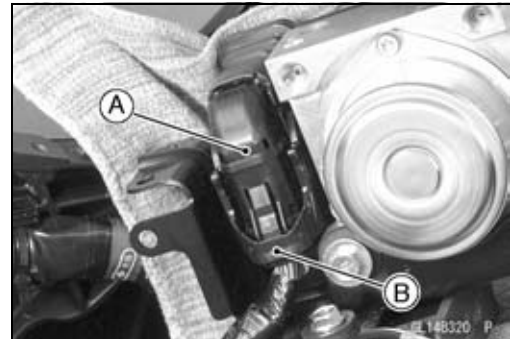

ABS Hydraulic Unit Inspection

- Remove the ABS hydraulic unit (see ABS Hydraulic Unit Removal).
- Visually inspect the ABS hydraulic unit.
- ★ Replace the ABS hydraulic unit if any of them are cracked, or otherwise damaged.

Anti-Lock Brake System (Equipped Models)

- Visually inspect the connector terminals [A].
- ★ Replace the ABS hydraulic unit or main harness if either of the terminals are cracked, bent, or otherwise damaged.
- ★ If the ABS hydraulic unit connector is clogged with mud or dust, blow it off with compressed air.

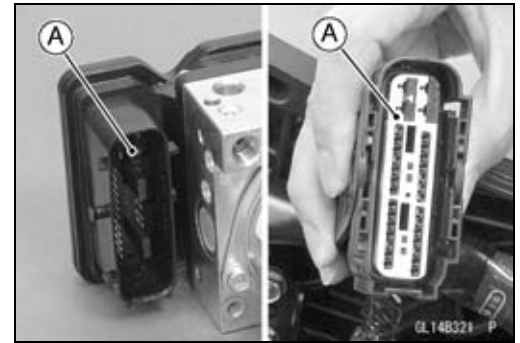

Front Wheel Rotation Sensor Removal

NOTICE

The wheel rotation sensor should be handled carefully, never struck sharply, as with a hammer, or allowed to fall on a hard surface since the wheel rotation sensor is precision made. Be careful not to get water or mud on the wheel rotation sensor. Do not try to disassemble or repair the wheel rotation sensor.

- Remove:
 - Upper Fairing (see Upper Fairing Removal in the Frame chapter)
 - Connector [A] (Disconnect)
 - Grommet [B]
 - Clamp [C]

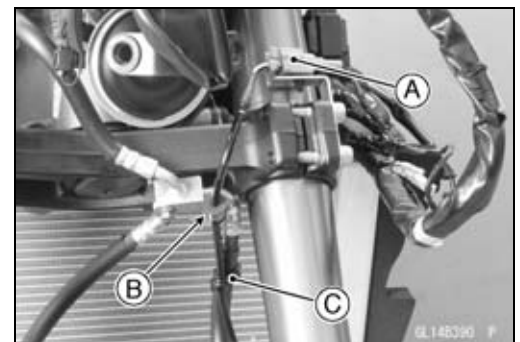

- Remove:
 - Clamp [A]
- Clear the sensor lead from the clamps [B].
- Remove:
 - Bolt [C]
 - Front Wheel Rotation Sensor [D]

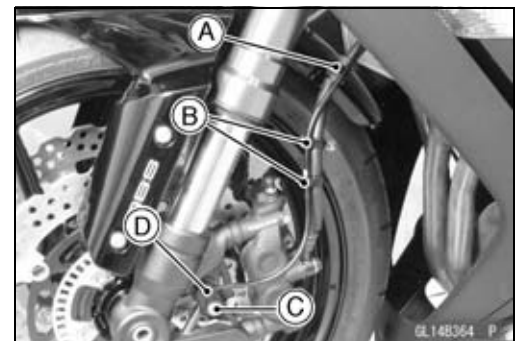

Front Wheel Rotation Sensor Installation

- Installation is the reverse of removal.
- Replace the brake hose clamp with a new one (ZX1000HB Early Model).
- For ZX1000HB Late Model ~, face the lock portion [A] of the brake hose clamp backward.
- Run the lead correctly (see Cable, Wire, and Hose Routing section in the Appendix chapter).

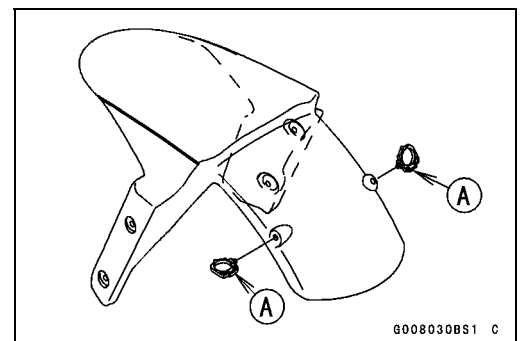

12-56 BRAKES

Anti-Lock Brake System (Equipped Models)

Rear Wheel Rotation Sensor Removal

NOTICE

The wheel rotation sensor should be handled carefully, never struck sharply, as with a hammer, or allowed to fall on a hard surface since the wheel rotation sensor is precision made. Be careful not to get water or mud on the wheel rotation sensor. Do not try to disassemble or repair the wheel rotation sensor.

- Remove:
 - Fuel Tank (see Fuel Tank Removal in the Fuel System (DFI) chapter)
 - Connector [A] (Disconnect)
- Clear the sensor lead from the clamps [B].

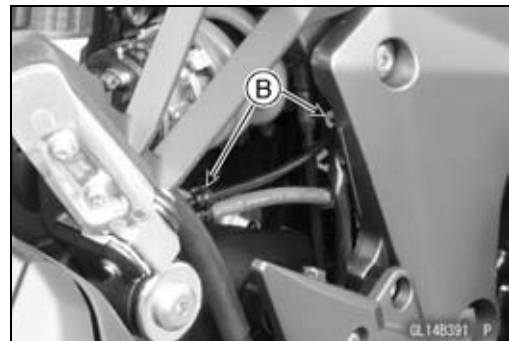
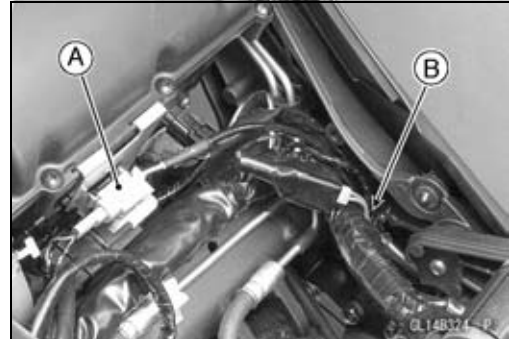

- Clear the sensor lead from the clamps [A].
- Remove:
 - Grommet [B]
 - Bolt [C]
 - Clamp [D]
 - Rear Wheel Rotation Sensor [E]

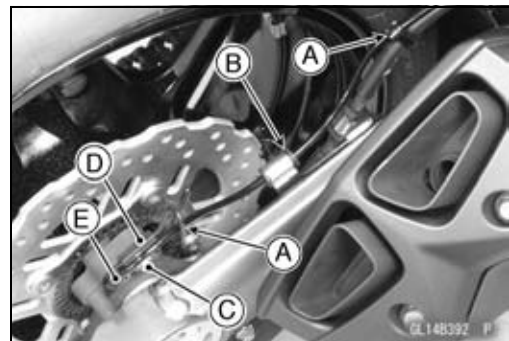

Rear Wheel Rotation Sensor Installation

- Installation is the reverse of removal.
- Run the lead correctly (see Cable, Wire, and Hose Routing section in the Appendix chapter).

Anti-Lock Brake System (Equipped Models)

Wheel Rotation Sensor Inspection

- Remove the front wheel rotation sensor [A] from the front fork.
- Remove the rear wheel rotation sensor [B] from the caliper bracket.
- Visually inspect the wheel rotation sensors.
- ★ Replace the wheel rotation sensor if it is cracked, bent, or otherwise damaged.

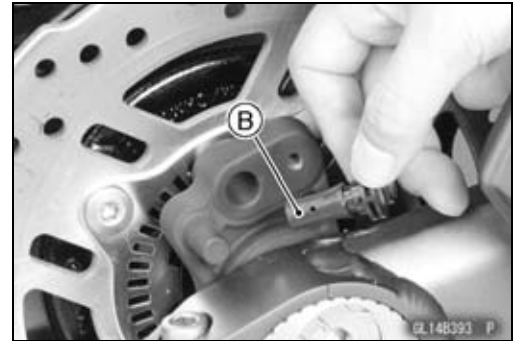
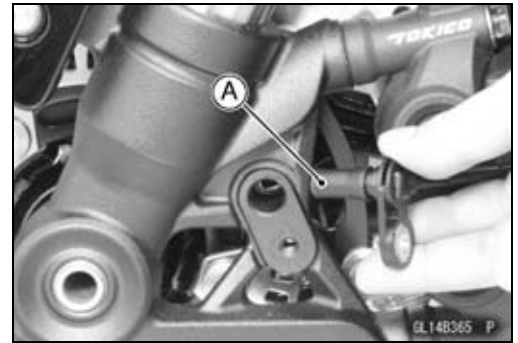

Wheel Rotation Sensor Air Gap Inspection

- Raise the front/rear wheel off the ground (see Front/Rear Wheel Removal in the Wheels/Tires chapter).
- Measure the air gap between the sensor and sensor rotor at several points by turning the wheel slowly.
Thickness Gauge [A]

Air Gap

Standard:

Front	1.98 ~ 2.86 mm (0.0780 ~ 0.113 in.)
Rear	1.12 ~ 1.85 mm (0.0441 ~ 0.0728 in.)

NOTE

○ The sensor air gap cannot be adjusted.

- ★ If the air gap is not within the specification, inspect the hub bearing (see Hub Bearing Inspection in the Wheels/Tires chapter), sensor installation condition and sensor (see Wheel Rotation Sensor Inspection).

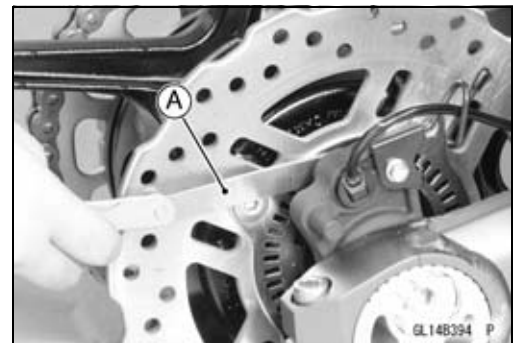
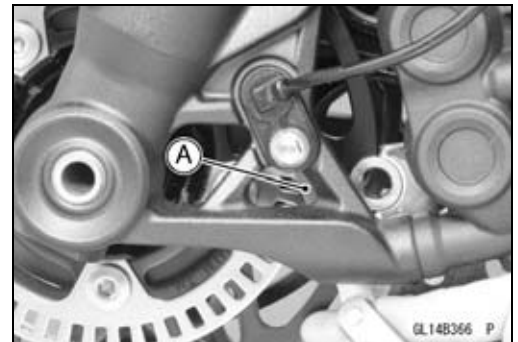

12-58 BRAKES

Anti-Lock Brake System (Equipped Models)

Wheel Rotation Sensor Rotor Inspection

- Remove:
 - Wheels (see Front/Rear Wheel Removal in the Wheels/Tires chapter)
 - Brake Disc Mounting Bolts [A]
 - Sensor Rotor [B]
 - Front Wheel [C]
 - Rear Wheel [D]

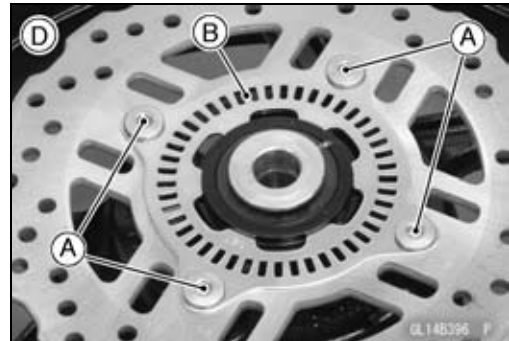
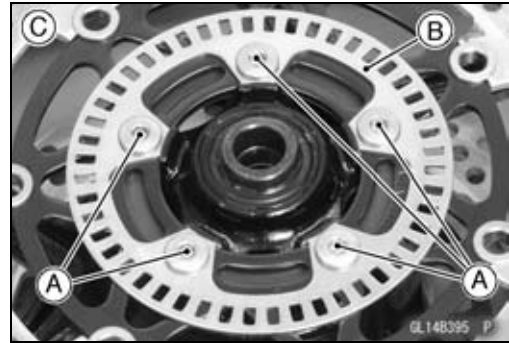

- Visually inspect the wheel rotation sensor rotor.
 - ★ If the rotor is deformed or damaged (chipped teeth [A]), replace the sensor rotor with a new one.
 - ★ If there is iron or other magnetic deposits [B], remove the deposits.

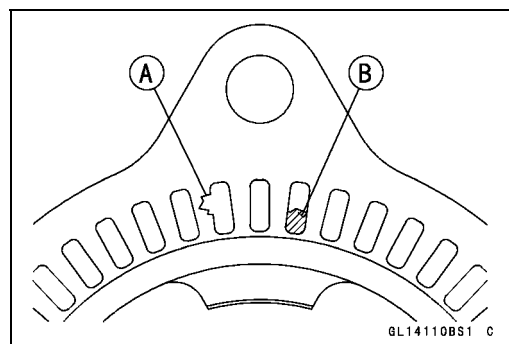
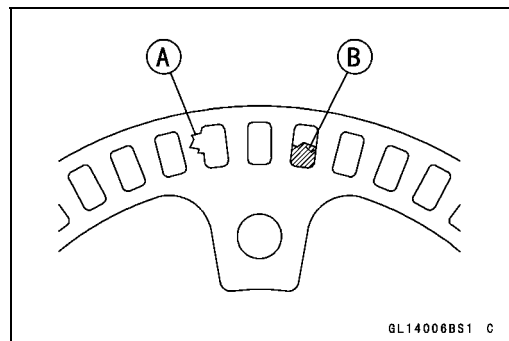

ABS Solenoid Valve Relay Fuse (20 A) Removal

- Refer to the Fuse Box Fuse Removal in the Electrical System chapter.

ABS Motor Relay Fuse (30 A) Removal

- Refer to the Fuse Box Fuse Removal in the Electrical System chapter.

ABS ECU Fuse (10 A) Removal

- Refer to the Fuse Box Fuse Removal in the Electrical System chapter.

Anti-Lock Brake System (Equipped Models)

Fuse Installation

- If a fuse fails during operation, inspect the electrical system to determine the cause, and then replace it with a new fuse of proper amperage (see Fuse Installation in the Electrical System chapter).

Fuse Inspection

- Remove the fuses (see ABS Solenoid Valve Relay Fuse (20 A)/ABS Motor Relay Fuse (30 A)/ABS ECU Fuse (10 A) Removal).
- Refer to the Fuse Inspection in the Electrical System chapter.

Suspension

Table of Contents

Exploded View.....	13-2
Specifications	13-6
Special Tools	13-7
Front Fork.....	13-9
Rebound Damping Force Adjustment	13-9
Spring Preload Adjustment	13-9
Compression Damping Force Adjustment (Right Side Only).....	13-10
Front Fork Removal (Each Fork Leg)	13-10
Front Fork Installation	13-11
Fork Oil Change.....	13-11
Front Fork Disassembly	13-17
Front Fork Assembly.....	13-18
Inner Tube, Outer Tube Inspection	13-19
Dust Seal Inspection.....	13-19
Spring Tension Inspection.....	13-19
Rear Shock Absorber	13-20
Rebound Damping Force Adjustment.....	13-20
Spring Preload Adjustment	13-20
Rear Shock Absorber Removal	13-21
Rear Shock Absorber Installation	13-21
Rear Shock Absorber Inspection	13-22
Rear Shock Absorber Scrapping	13-22
Rear Shock Absorber Bearing Removal.....	13-22
Rear Shock Absorber Bearing Installation	13-22
Swingarm.....	13-23
Swingarm Removal.....	13-23
Swingarm Installation.....	13-24
Swingarm Bearing Removal	13-25
Swingarm Bearing Installation	13-25
Swingarm Bearing, Sleeve Inspection	13-26
Swingarm Bearing Lubrication	13-26
Chain Guide Inspection.....	13-26
Tie-Rod, Rocker Arm.....	13-27
Tie-Rod Removal	13-27
Tie-Rod Installation	13-27
Rocker Arm Removal.....	13-27
Rocker Arm Installation.....	13-27
Tie-Rod and Rocker Arm Bearing Removal.....	13-28
Tie-Rod and Rocker Arm Bearing Installation.....	13-28
Rocker Arm/Tie-Rod Bearing, Sleeve Inspection	13-29
Rocker Arm/Tie-Rod Bearing Lubrication	13-29

13-2 SUSPENSION

Exploded View

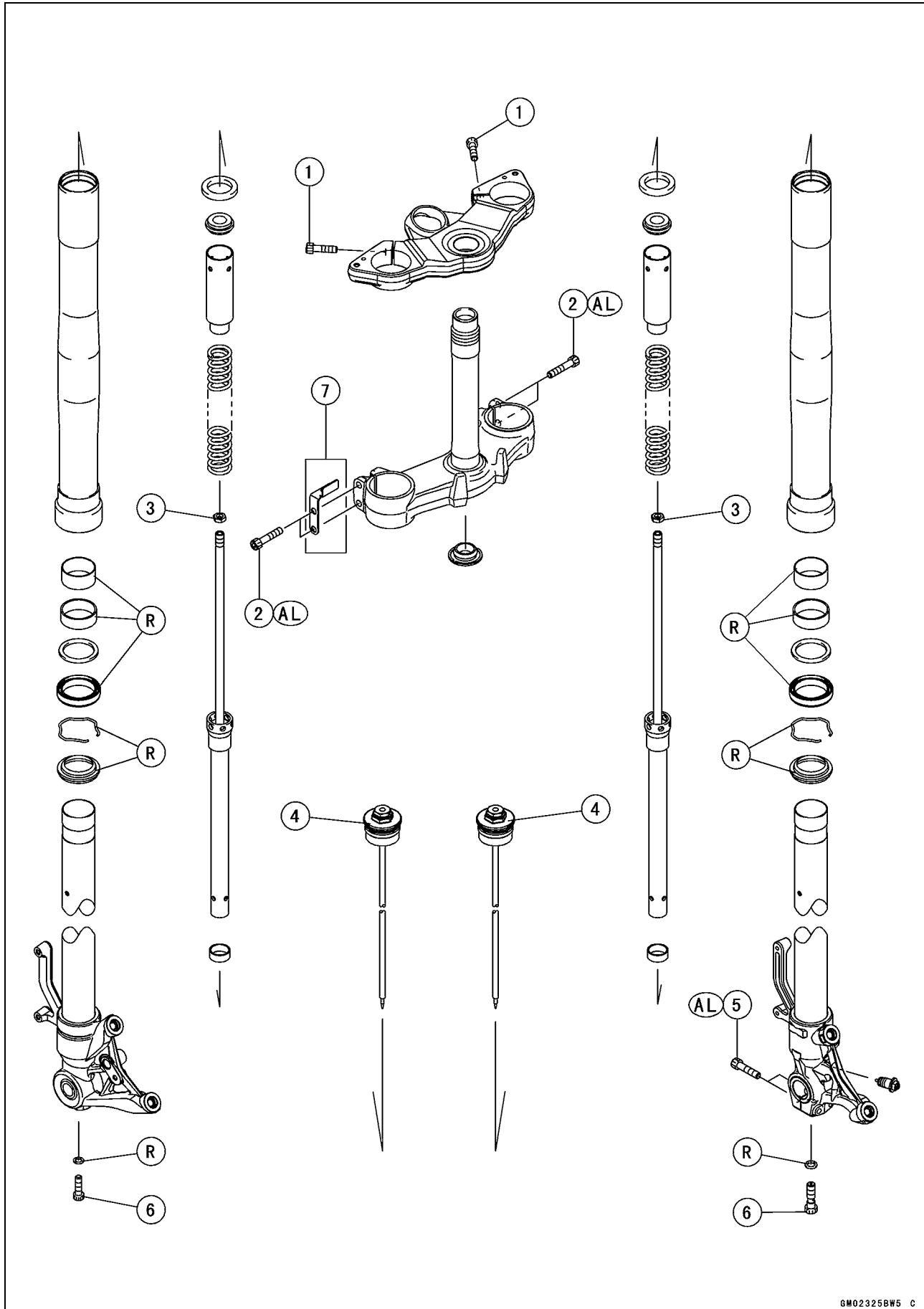

Exploded View

No.	Fastener	Torque			Remarks
		N-m	kgf-m	ft-lb	
1	Upper Front Fork Clamp Bolts	20	2.0	15	
2	Lower Front Fork Clamp Bolts	25	2.5	18	AL
3	Piston Rod Nuts	20	2.0	15	
4	Front Fork Top Plugs	34	3.5	25	
5	Front Axle Clump Bolts	20	2.0	15	AL
6	Front Fork Bottom Allen Bolts	35	3.6	26	

7. ABS Equipped Models

AL: Tighten the two clamp bolts alternately two times to ensure even tightening torque.

R: Replacement Parts

13-4 SUSPENSION

Exploded View

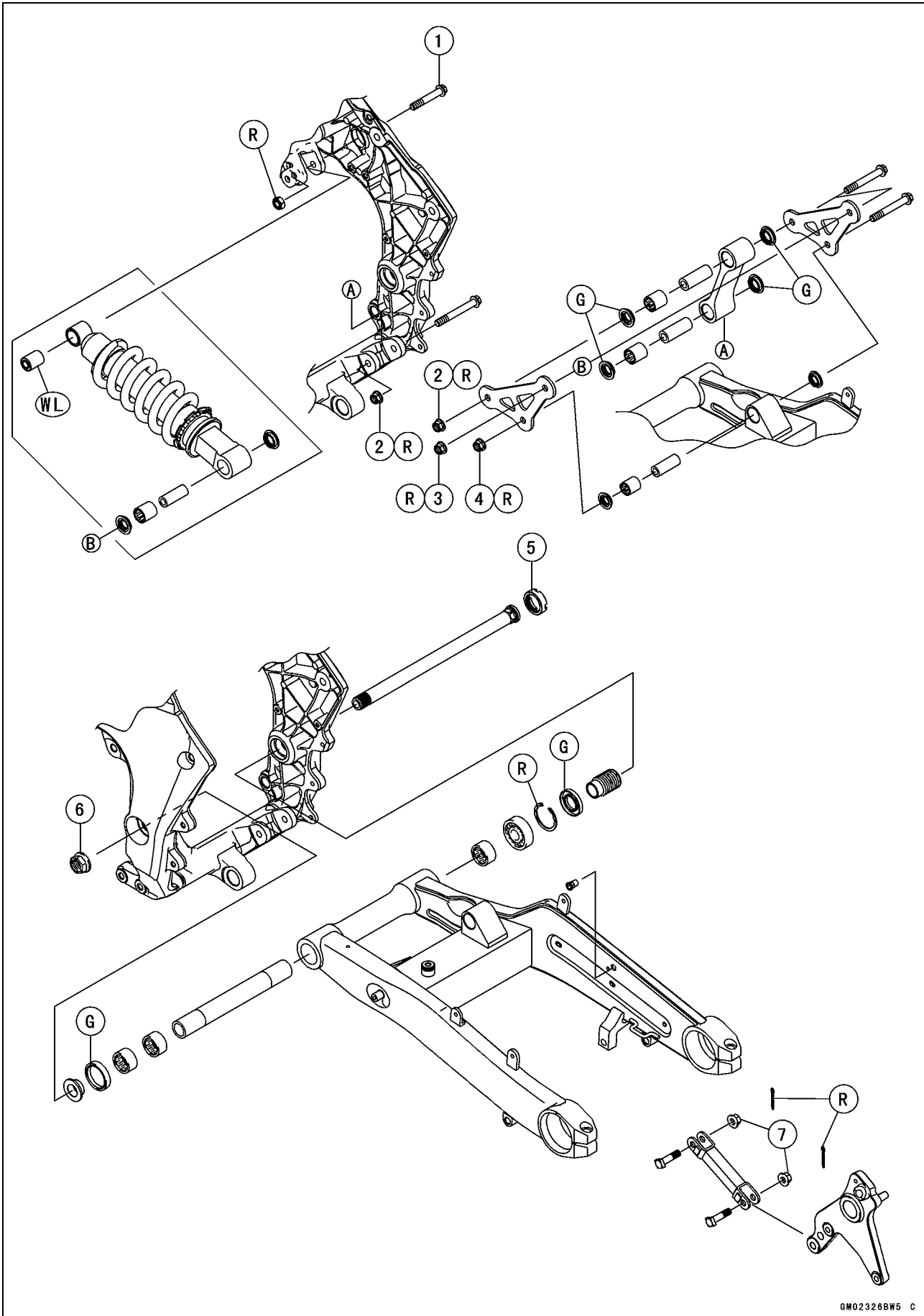

Exploded View

No.	Fastener	Torque			Remarks
		N·m	kgf·m	ft·lb	
1	Rear Shock Absorber Bolt (Upper)	34	3.5	25	
2	Tie-rod Nuts	34	3.5	25	R
3	Rear Shock Absorber Nut (Lower)	34	3.5	25	R
4	Rocker Arm Nut	34	3.5	25	R
5	Swingarm Pivot Adjusting Collar Locknut	98	10	72	
6	Swingarm Pivot Shaft Nut	108	11.0	79.7	
7	Torque Link Nuts	34	3.5	25	

G: Apply grease.

R: Replacement Parts

WL: Apply soap and water solution or rubber lubricant.

13-6 SUSPENSION

Specifications

Item	Standard
Front Fork (Per One Unit) Fork Inner Tube Diameter Air Pressure Rebound Damper Setting Compression Damper Setting (Right Side Only) Fork Spring Preload Setting Fork Oil: Recommend Oil Amount: When Changing Oil After Disassembly and Completely Dry Fork Oil Level: (Fully Compressed, without Spring, below from the Top of the Outer Tube) Fork Spring Free Length	$\phi 41$ mm (1.6 in.) Atmospheric pressure (non-adjustable) 2 turns out from the fully clockwise position (Usable range: 0 \longleftrightarrow 3 1/2 turns out) 1 1/4 turns out from the fully clockwise position (Usable range: 0 \longleftrightarrow 3 turns out) 7 turns in from the fully counterclockwise position (Usable range: 0 \longleftrightarrow 15 turns in) SHOWA SS-47 or equivalent Approx. 420 mL (14.2 US oz.) 492 \pm 2.5 mL (16.6 \pm 0.085 US oz.) 91 \pm 2 mm (3.58 \pm 0.08 in.) 313 mm (12.3 in.) (Service Limit: 307 mm (12.1 in.))
Rear Shock Absorber Rebound Damper Setting Spring Preload Setting Position Gas Pressure	1 1/4 turns out from the fully clockwise position (Usable Range: 0 \longleftrightarrow 2 1/2 turns out) 4th position (from the weakest position) (Adjustable Range: 0 ~ 10th position) 980 kPa (10 kgf/cm ² , 142 psi, Non-adjustable)

Special Tools

Inside Circlip Pliers:

57001-143

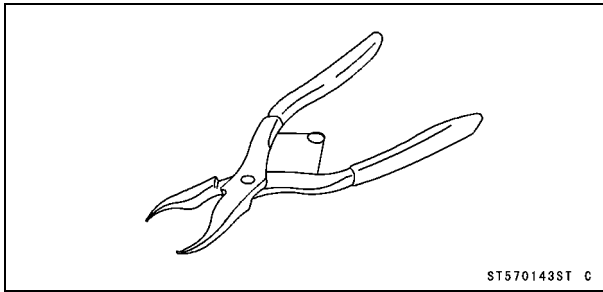

ST570143ST C

Fork Oil Seal Driver, $\phi 41$:

57001-1288

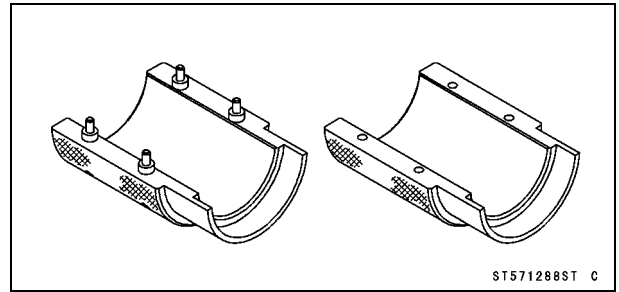

ST571288ST C

Oil Seal & Bearing Remover:

57001-1058

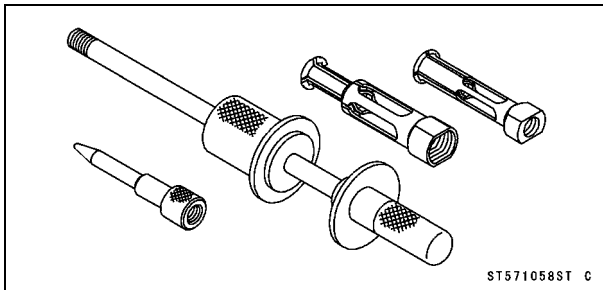

ST571058ST C

Fork Piston Rod Puller, M12 \times 1.25:

57001-1289

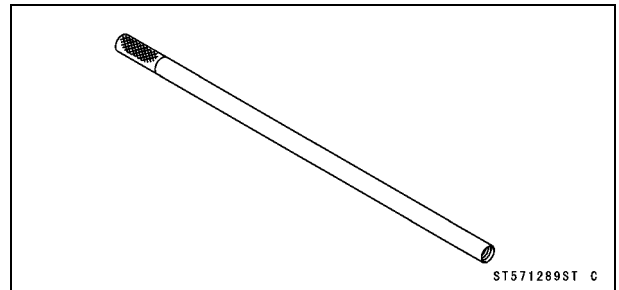

ST571289ST C

Bearing Driver Set:

57001-1129

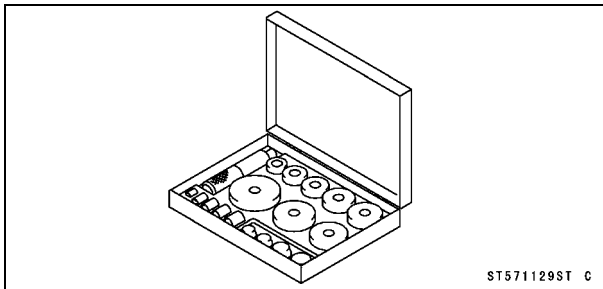

ST571129ST C

Fork Oil Level Gauge:

57001-1290

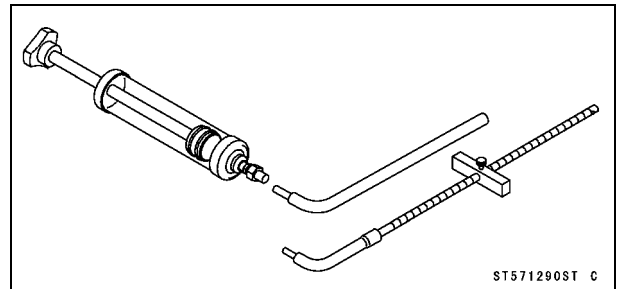

ST571290ST C

Jack:

57001-1238

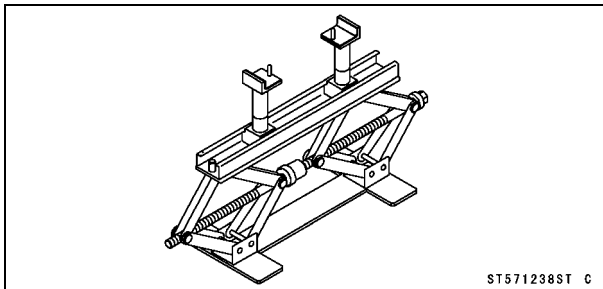

ST571238ST C

Fork Spring Stopper:

57001-1374

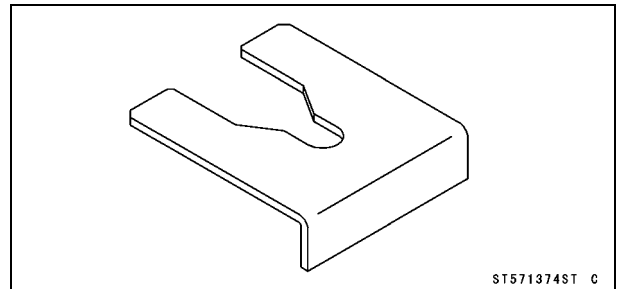

ST571374ST C

Bearing Remover Head, $\phi 15 \times \phi 17$:

57001-1267

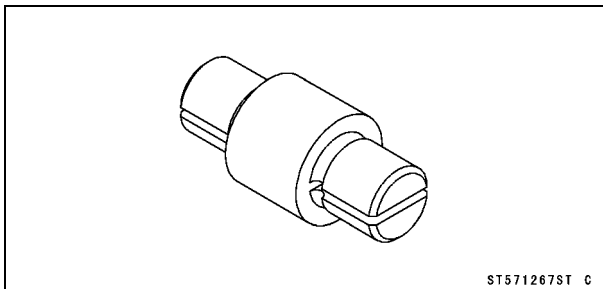

ST571267ST C

Bearing Remover Shaft, $\phi 13$:

57001-1377

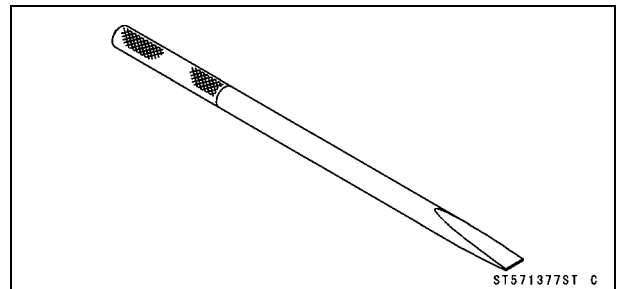

ST571377ST C

13-8 SUSPENSION

Special Tools

Hook Wrench T=3.2 R37:

57001-1539

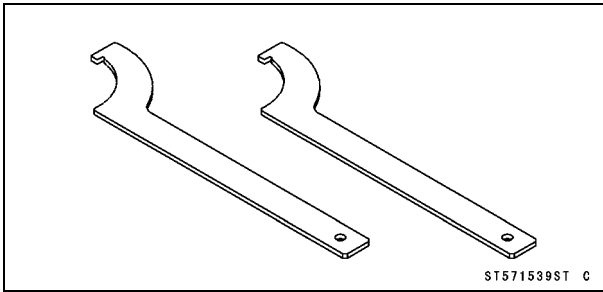

Needle Bearing Driver, $\phi 17/\phi 18$:

57001-1609

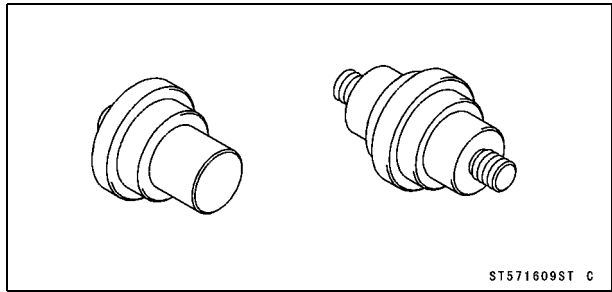

Fork Spring Compressor:

57001-1587

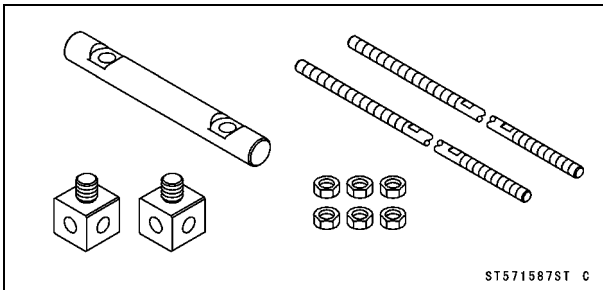

Needle Bearing Driver, $\phi 28$:

57001-1610

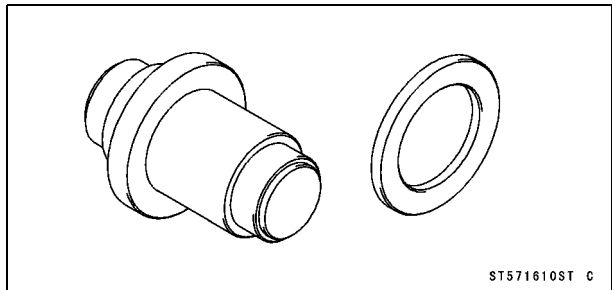

Swingarm Pivot Nut Wrench:

57001-1597

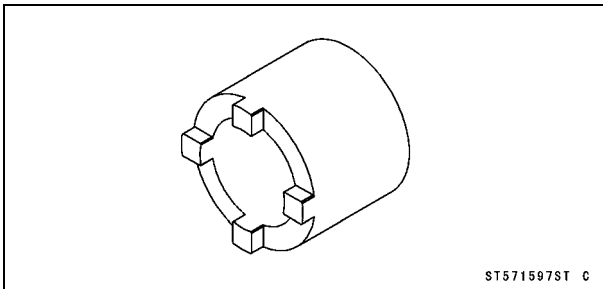

Clamp:

57001-1693

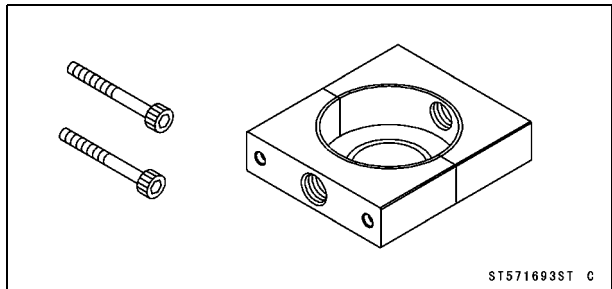

Jack Attachment:

57001-1608

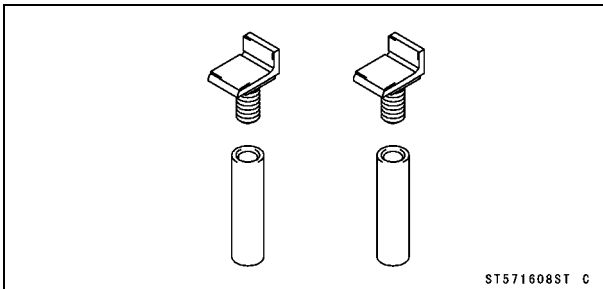

Bar:

57001-1751

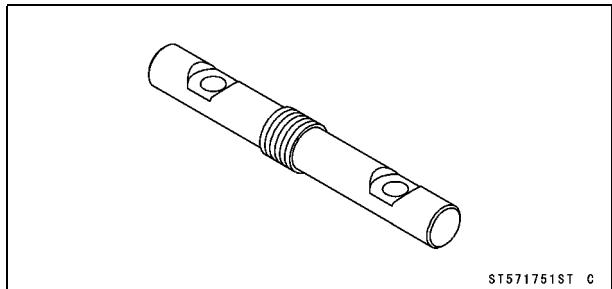

Front Fork

Rebound Damping Force Adjustment

- To adjust the rebound damping force, turn the rebound damping adjuster [A] until you feel a click.
- The standard adjuster setting is the **2 turns out** from the fully clockwise position.

⚠ WARNING

If both adjusters are not adjusted equally, handling may be impaired and a hazardous condition may result. Be sure the adjusters are set equally.

- The damping force can be left soft for average riding. But it should be adjusted harder for high speed riding or riding with a passenger. If the damping feels too soft or too stiff, adjust it in accordance with the following table.

Rebound Damping Force Adjustment

Adjuster Position	Damping Force	Setting	Load	Road	Speed
3 1/2 turns out	Weak	Soft	Light	Good	Low
↑	↑	↑	↑	↑	↑
↓	↓	↓	↓	↓	↓
0	Strong	Hard	Heavy	Bad	High

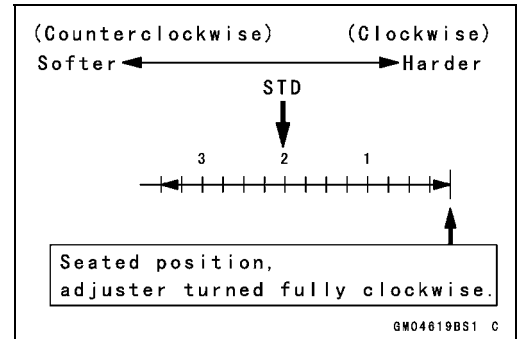
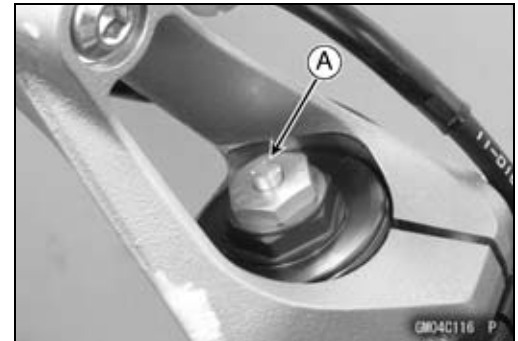

Spring Preload Adjustment

- Turn the spring preload adjuster [A] to change spring preload setting.
- The standard adjuster setting is the **7 turns in** from the fully counter-clockwise position.

⚠ WARNING

If both adjusters are not adjusted equally, handling may be impaired and a hazardous condition may result. Be sure the adjusters are set equally.

- The spring preload can be left soft for average riding. But it should be adjusted harder for high speed riding or riding with a passenger. If the spring action feels too soft or too stiff, adjust it in accordance with the following table.

Spring Action

Adjuster Position	Damping Force	Setting	Load	Road	Speed
0	Weak	Soft	Light	Good	Low
↑	↑	↑	↑	↑	↑
↓	↓	↓	↓	↓	↓
15 turns in	Strong	Hard	Heavy	Bad	High

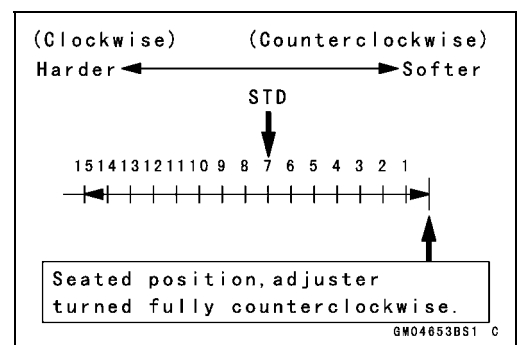

13-10 SUSPENSION

Front Fork

Compression Damping Force Adjustment (Right Side Only)

- To adjust the compression damping force, turn the compression damping adjuster [A] until you feel a click.
- The standard adjuster setting is the **1 1/4 turns out** from the fully clockwise position.

⚠ WARNING

If both adjusters are not adjusted equally, handling may be impaired and a hazardous condition may result. Be sure the adjusters are set equally.

- The damping force can be left soft for average riding. But it should be adjusted harder for high speed riding or riding with a passenger. If the damping feels too soft or too stiff, adjust it in accordance with the following table.

Compression Damping Force Adjustment

Adjuster Position	Damping Force	Setting	Load	Road	Speed
3 Turns out	Weak	Soft	Light	Good	Low
↑	↑	↑	↑	↑	↑
↓	↓	↓	↓	↓	↓
0	Strong	Hard	Heavy	Bad	High

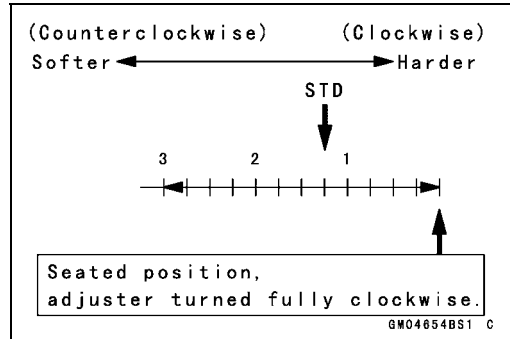
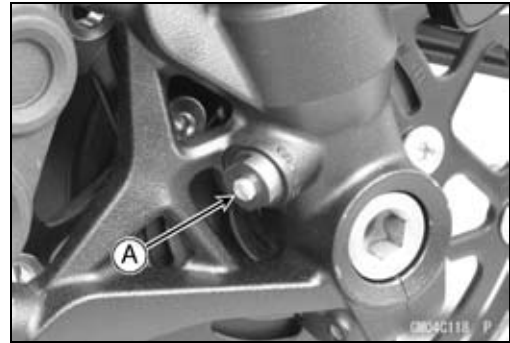

Front Fork Removal (Each Fork Leg)

- Remove:
 - Upper Fairing (see Upper Fairing Removal in the Frame chapter)
 - Front Wheel (see Front Wheel Removal in the Wheels/Tires chapter)
- Remove the handle bar holder bolt [A].
- Loosen the upper front fork clamp bolts [B] and lower front clamp bolts [C].

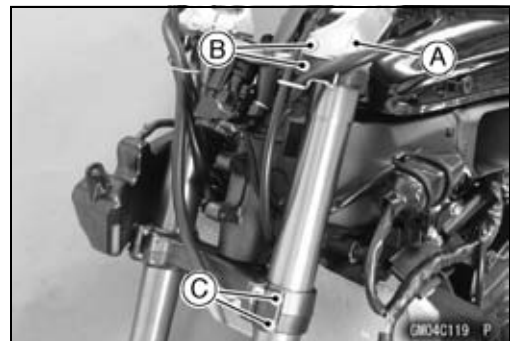

- If fork leg is to be disassembled, loosen the upper and lower front fork clamp bolts to lower the fork leg [A] as shown. And retighten the lower front fork clamp bolts. Then, loosen the top plug beforehand.

NOTE

- Loosen the top plug after loosening the upper front fork clamp bolt.
- Loosen the lower front fork clamp bolts.
- With a twisting motion, work the fork leg down and out.



Front Fork

Front Fork Installation

- Install the fork so that the top end [A] of the outer tube as shown in the figure.
28 mm (1.10 in.) [B]
- Tighten:
 - Torque - Lower Front Fork Clamp Bolts : 25 N·m (2.5 kgf·m, 18 ft·lb)**
 - Front Fork Top Plugs: 34 N·m (3.5 kgf·m, 25 ft·lb)**
 - Upper Front Fork Clamp Bolts: 20 N·m (2.0 kgf·m, 15 ft·lb)**

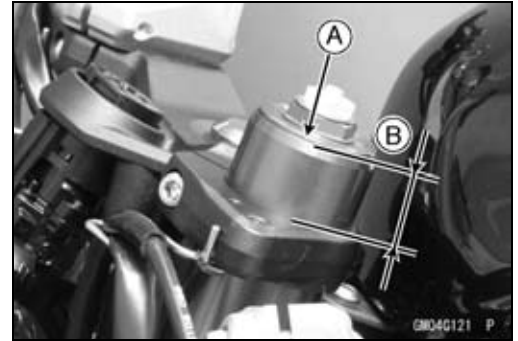

NOTE

- Tighten the top plug before tightening the upper front fork clamp bolt.
- Tighten the two clamp bolts (lower) alternately two times to ensure even tightening torque.
- Install the removed parts (see appropriate chapters).
- Adjust:
 - Spring Preload (see Spring Preload Adjustment)
 - Rebound Damping Force (see Rebound Damping Force Adjustment)
 - Compression Damping Force (see Compression Damping Force Adjustment)

Fork Oil Change

- Remove the front fork (see Front Fork Removal).
- Hold the inner tube lower end in a vice.
- Unscrew the top plug [A] out of the outer tube.



- Holding the top plug [A] with a wrench [B], tighten the spring preload adjuster [C].

NOTE

- After tightening, lift the top plug to make the space.
- Slide down the damper [D].

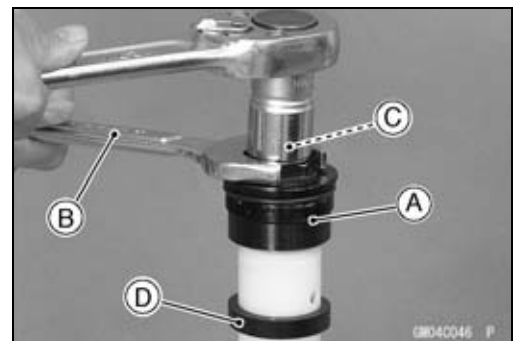

13-12 SUSPENSION

Front Fork

- Install the clamps [A] as shown in the figure.

NOTE

○ Set the cutout [B] of the clamp to the groove [C] of collar [D], pull up the outer tube [E] to hold it by the clamps, and then tighten the two bolts [F]. The outer tube is used as a guide.

Special Tools - Fork Spring Compressor: 57001-1587
Clamp : 57001-1693

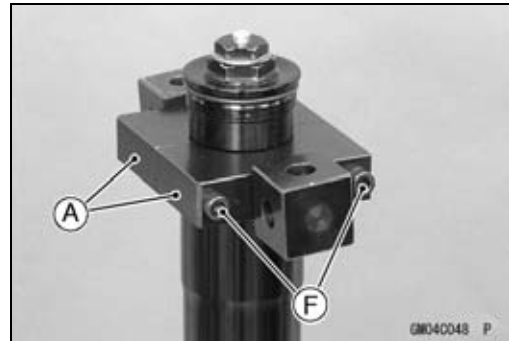
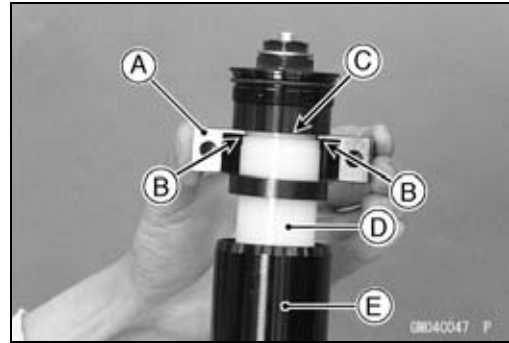

- Insert the holder bar [A] into the axle hole of the front fork [B].

Special Tool - Bar: 57001-1751 (For Left Fork Leg)

○ Position the bar left and right and evenly.

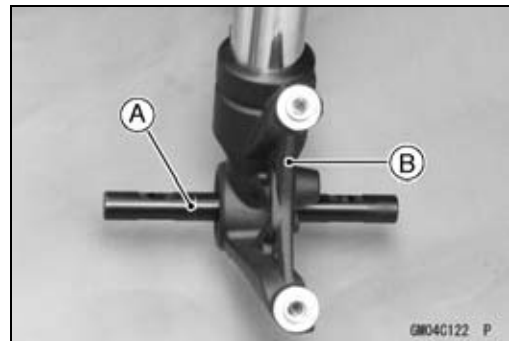

- Insert the compression shaft and install the nut.
- Insert the lower end of the compression shaft [A] into the hole [B] of the holder bar.

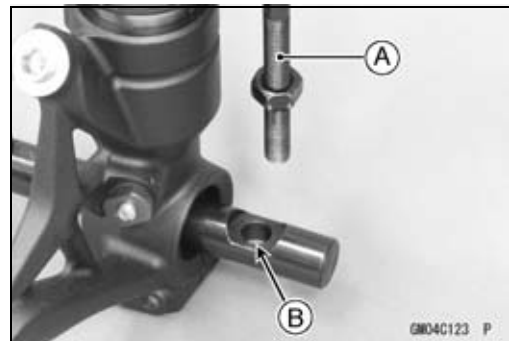

- Screw the adjust nut [A] onto the compression shaft as shown in the figure.
- Screw the locknut [B].
- Set the other side compression shaft same process.

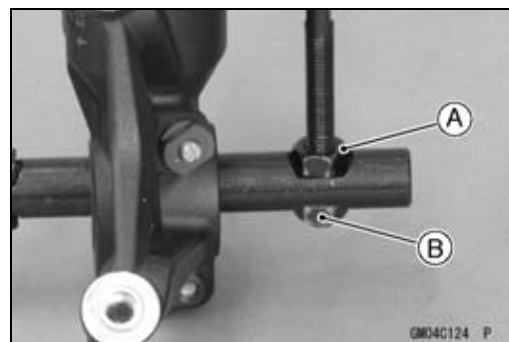

Front Fork

- Set the holder bar [A] and compression shafts [B].

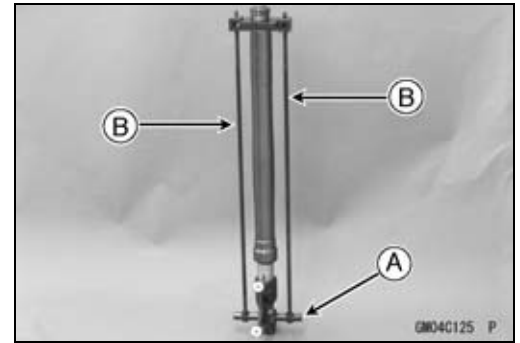

- Screw in the nuts [A] until the piston rod nut comes out.

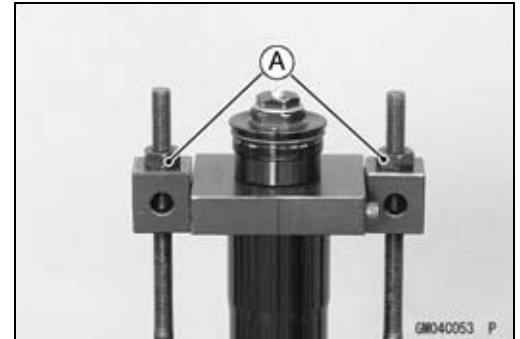

- While holding up the top plug [A], insert the fork spring stopper [B] between the piston rod nut [C] and the slider.

Special Tool - Fork Spring Stopper: 57001-1374

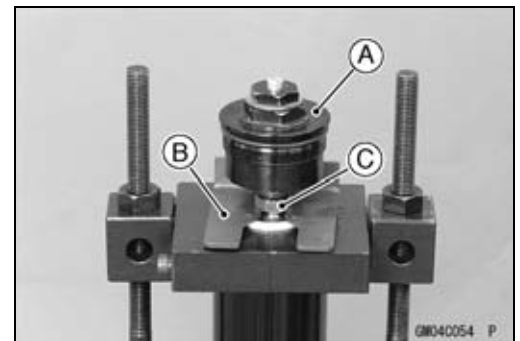

- Holding the spring preload adjuster [A] with a wrench [B], loosen the piston rod nut [C].

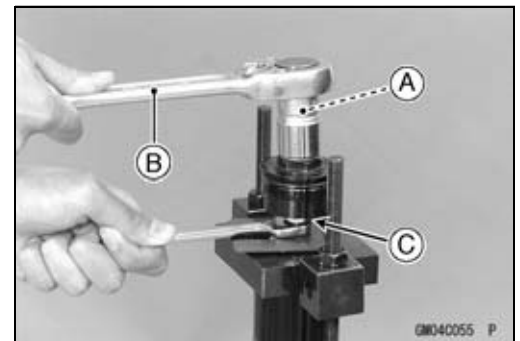

- Remove:
 - Top Plug with the Rebound Damping Adjuster Rod Damper [A]
 - Slider [B]
 - Collar [C]
 - Fork Spring [D]

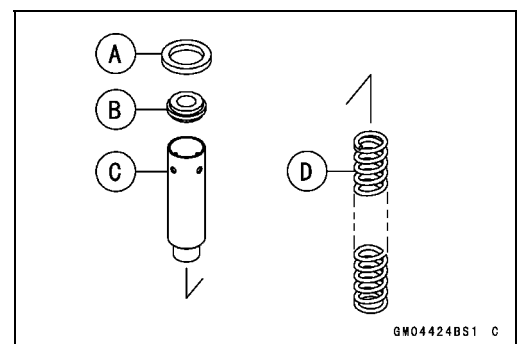

13-14 SUSPENSION

Front Fork

- Drain the fork oil into a suitable container.
- Pump the piston rod [A] up and down at least ten times to expel the oil from the fork.

**Special Tool - Fork Piston Rod Puller, M12 x 1.25 [B]:
57001-1289**

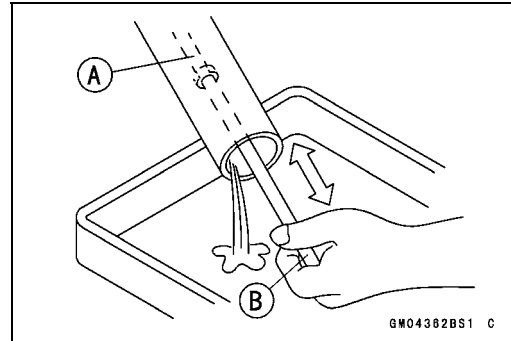

- Hold the fork tube upright, press the outer tube [A] and the piston rod all the way down.
- Pour in the type and amount of fork oil specified.

Fork Oil

Recommended Oil:

SHOWA SS-47 or equivalent

Amount (Per Side):

When changing oil:

Approx. 420 mL (14.2 US oz.)

After disassembly and completely dry:

492 ±2.5 mL (16.6 ±0.085 US oz.)

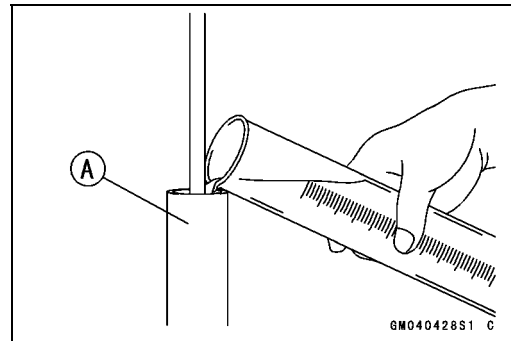

- ★ If necessary, measure the oil level as follows.
- Hold the inner tube vertically in a vise.
- Using the piston rod puller [A], move the piston rod [B] up and down more than ten times in order to expel all the air from the fork oil.

**Special Tool - Fork Piston Rod Puller, M12 x 1.25 [A]:
57001-1289**

- Remove the piston rod puller.
- Wait until the oil level settles.
- With the fork fully compressed and the piston rod fully pushed in, insert a tape measure or rod into the inner tube, and measure the distance from the top of the outer tube to the oil.

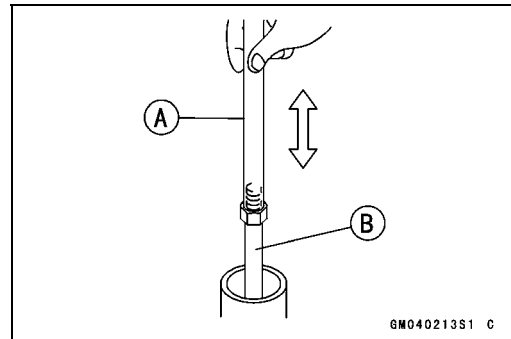

Front Fork

Oil Level (fully compressed, without spring)

Standard:

91 ±2 mm (3.58 ±0.08 in.) (from the top of the outer tube)

NOTE

○ Fork oil level may also be measured using the fork oil level gauge.

Special Tool - Fork Oil Level Gauge [A]: 57001-1290

- With the fork fully compressed and without fork spring, insert the gauge tube into the inner tube [B] and position the stopper across the top end [C] of the outer tube [D].
- Set the gauge stopper [E] so that its lower side shows the oil level distance specified [F].
- Pull the handle slowly to pump out the excess oil until the oil no longer comes out.
- ★ If no oil is pumped out, there is insufficient oil in the inner tube. Pour in enough oil, then pump out the excess oil as shown above.

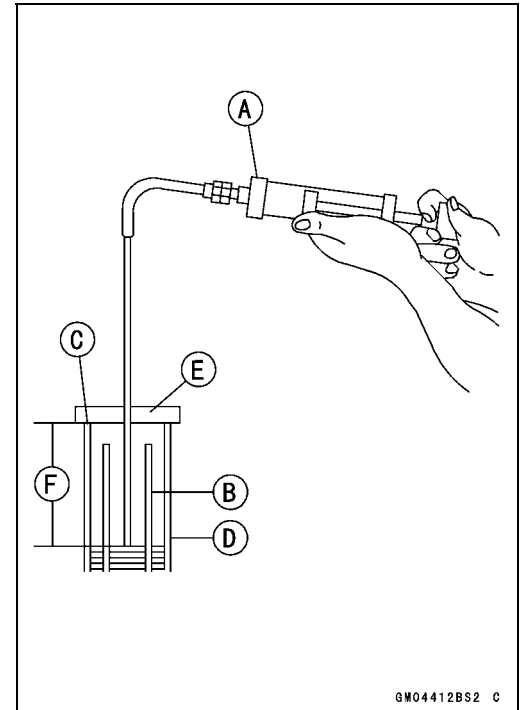

- Screw on the rod nut [A] fully to the piston rod [B].

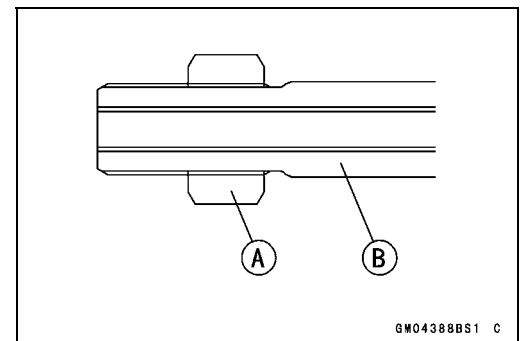

- Screw the fork piston rod puller onto the end of the piston rod.

Special Tool - Fork Piston Rod Puller, M12 × 1.25: 57001-1289

- Pull the puller up above the outer tube top.
- Install the fork spring [A] with the smaller end [B] facing upward.

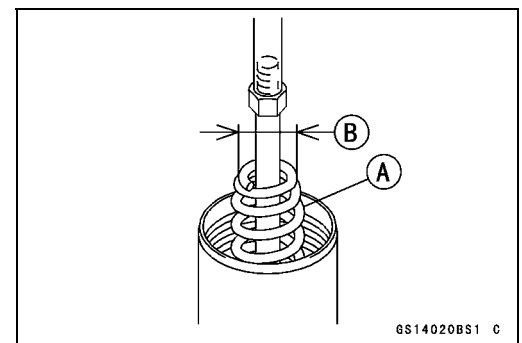

- Install:
 - Collar [A]
 - Damper [B]
 - Slider [C]

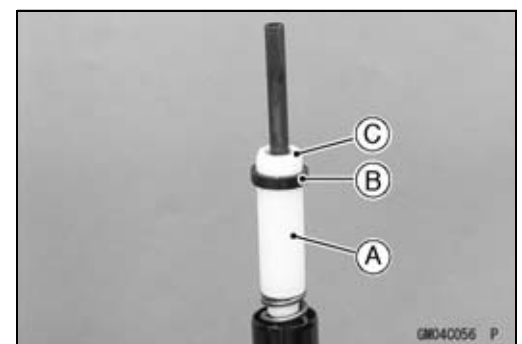

13-16 SUSPENSION

Front Fork

- Check the distance between the upper end [A] of the spring preload adjuster [B] and rebound damping adjuster [C] with a pair of vernier caliper.
1.5 mm (0.059 in.) [D]

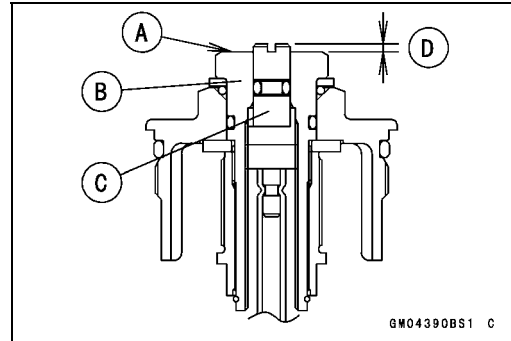

- Set the fork spring compressor on the slider [A] using the outer tube as a guide.

Special Tools - Fork Spring Compressor: 57001-1587
Clamp: 57001-1693

NOTE

- Set the cutout of the clamp to the slider.

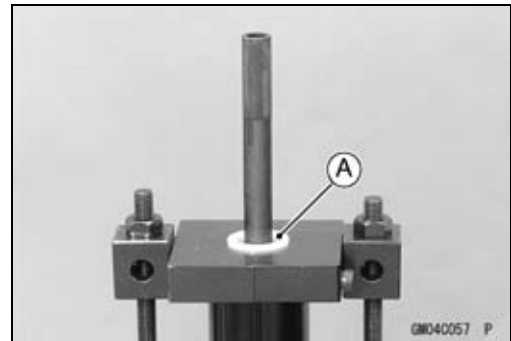

- While holding up the piston rod puller, insert the fork spring stopper between the piston rod nut and the slider.

Special Tool - Fork Spring Stopper: 57001-1374

- Remove the piston rod puller.
- Insert the rebound damping adjuster rod into the holes of the piston rod.
- Screw in the top plug until it stops onto the piston rod.

- Check the O-ring [A] on the top plug and replace top plug with a new one if damaged.

○ Apply grease to the new O-ring.

- Holding the spring preload adjuster [B] with a wrench [C], tighten the piston rod nut [D] against the top plug.

Torque - Piston Rod Nuts: 20 N·m (2.0 kgf·m, 15 ft·lb)

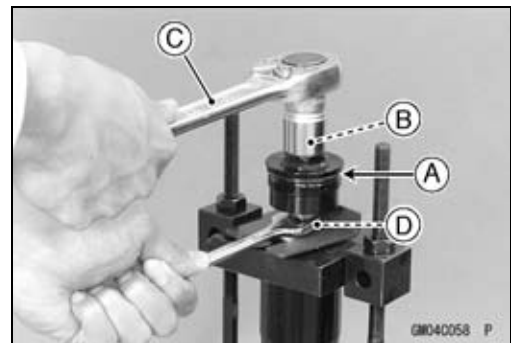

- While holding up the top plug [A], pull out the fork spring stopper [B].

- Remove the fork spring compressor.

- Raise the outer tube and screw the top plug into it.

- Install the front fork (see Front Fork Installation).

- Adjust the spring preload (see Spring Preload Adjustment)

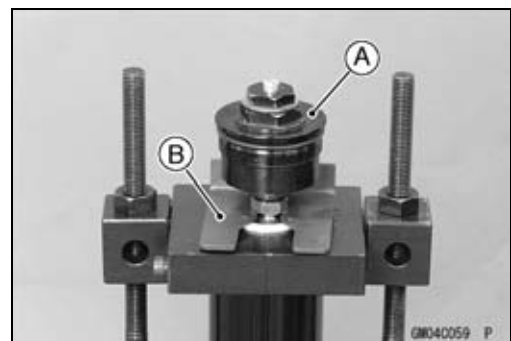

Front Fork

Front Fork Disassembly

- Remove the front fork (see Front Fork Removal).
- Drain the fork oil (see Fork Oil Change).
- Install the suitable pipe ($\phi 26 \sim \phi 32$) [A] into the cylinder unit.
- Set the fork leg inverted.
- While pushing down [B] the fork leg, loosen the bottom Allen bolt.
- Remove the Allen bolt and gasket.

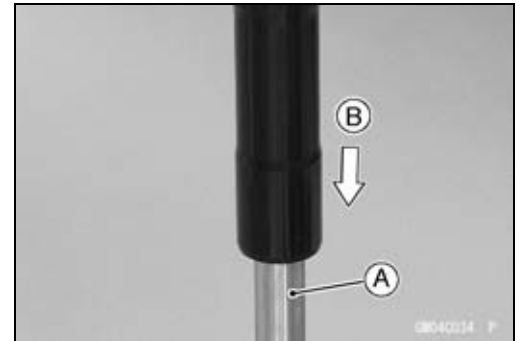

- Take the cylinder unit [A] and center ring plate [B] out of the inner tube.

○ Do not disassemble the cylinder unit.

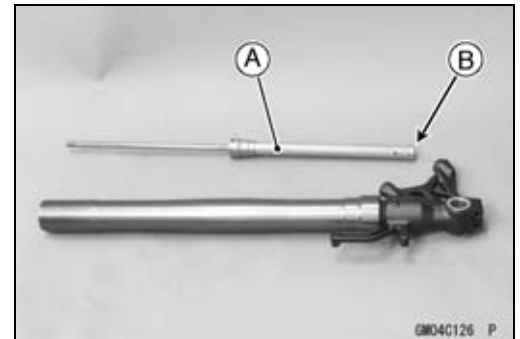

- Separate the inner tube from the outer tube as follows.

○ Slide up the dust seal [A].

○ Remove the retaining ring [B] from the outer tube.

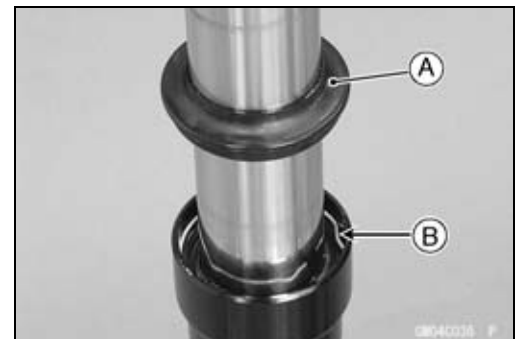

○ Holding the outer tube [A] by hand, pull the inner tube [B] several times to pull out the outer tube.

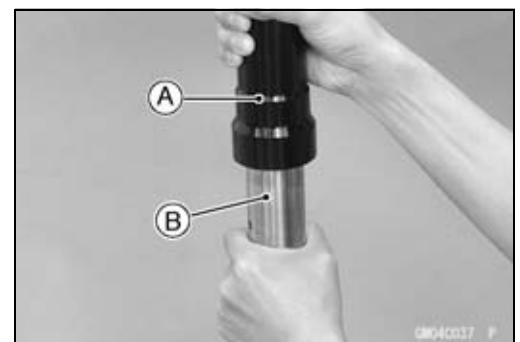

- Remove the inner tube guide bushing [A], outer tube guide bushing [B], washer [C], oil seal [D] from the inner tube.

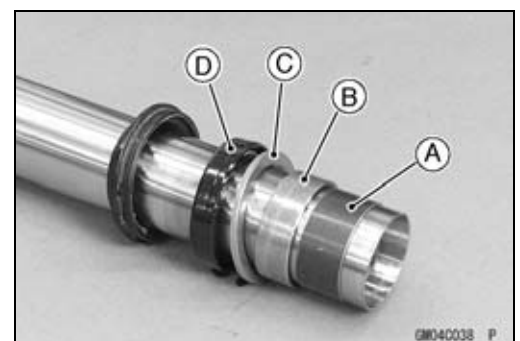

13-18 SUSPENSION

Front Fork

Front Fork Assembly

- Replace the following parts with new one.
 - Oil Seal [A]
 - Outer Tube Guide Bushing [B]
 - Inner Tube Guide Bushing [C]
 - Dust Seal [D]
 - Retaining Ring [E]
 - Bottom Allen Bolt Gasket
- Install the following parts onto the inner tube.
 - Dust Seal
 - Retaining Ring
 - Oil Seal
 - Washer [F]
 - Outer Tube Guide Bushing
 - Inner Tube Guide Bushing
- Insert the inner tube to the outer tube.
- Fit the new outer tube guide bushing [A] into the outer tube.

NOTE

○ When assembling the new outer tube guide bushing, hold the washer against the new outer tube guide bushing and tap the washer with the fork oil seal driver [B] until it stops.

Special Tool - Fork Oil Seal Driver, $\phi 41$: 57001-1288

- Install the oil seal by using the fork oil seal driver.
- Special Tool - Fork Oil Seal Driver, $\phi 41$: 57001-1288**
- Install the retaining ring and dust seal into the outer tube.
- Install the center ring plate [A] on the cylinder unit.
- Insert the center ring plate and cylinder unit as a set into the inner tube.

- Insert the suitable pipe into the cylinder unit.
- While pushing down [A] the fork leg, tighten the front fork bottom Allen bolt [B].
- Tighten:
 - Torque - Front Fork Bottom Allen Bolts: 35 N·m (3.6 kgf·m, 26 ft·lb)**
- Pour in the specified type of oil (see Fork Oil Change).

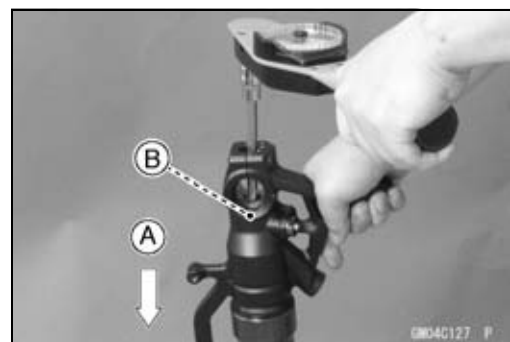
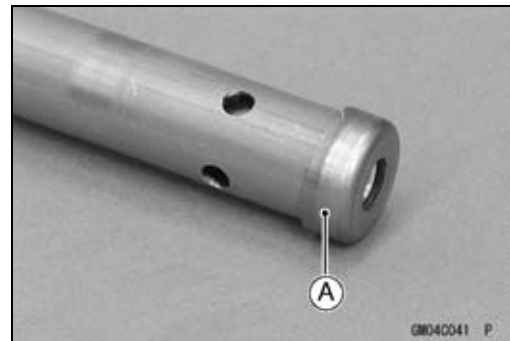
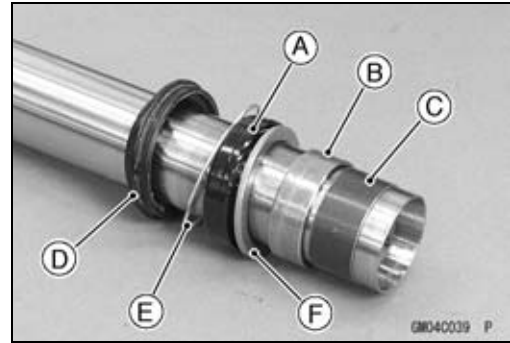

Front Fork

Inner Tube, Outer Tube Inspection

- Visually inspect the inner tube [A], and repair any damage.
- Nick or rust damage can sometimes be repaired by using a wet-stone to remove sharp edges or raised areas which cause seal damage.
- ★ If the damage is not repairable, replace the inner tube. Since damage to the inner tube damages the oil seal, replace the oil seal whenever the inner tube is repaired or replaced.

NOTICE

If the inner tube is badly bent or creased, replace it. Excessive bending, followed by subsequent straightening, can weaken the inner tube.

- Temporarily assemble the inner tube [A] and outer tube [B], and pump [C] them back and forth manually to check for smooth operation.
- ★ If you feel binding or catching, the inner and outer tubes must be replaced.

⚠ WARNING

A straightened inner or outer fork tube may fall in use, possibly causing an accident resulting in serious injury or death. Replace a badly bent or damaged inner or outer tube and inspect the other tube carefully before reusing it.

Dust Seal Inspection

- Inspect the dust seal [A] for any signs of deterioration or damage.
- ★ Replace it if necessary.

Spring Tension Inspection

- Since a spring becomes shorter as it weakens, check its free length [A] to determine its condition.
- ★ If the spring of either fork leg is shorter than the service limit, it must be replaced. If the length of a replacement spring and that of the remaining spring vary greatly, the remaining spring should also be replaced in order to keep the fork legs balanced for motorcycle stability.

Spring Free Length

Standard: 313 mm (12.3 in.)

Service Limit: 307 mm (12.1 in.)

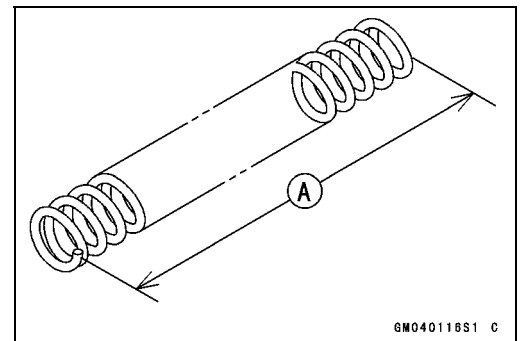
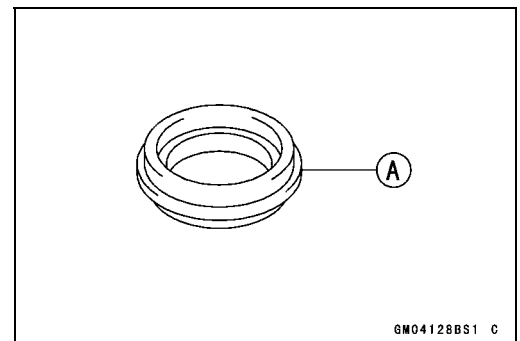
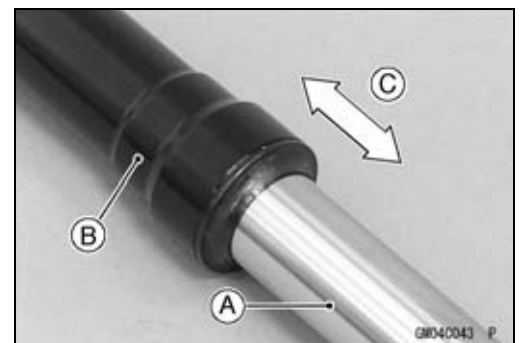
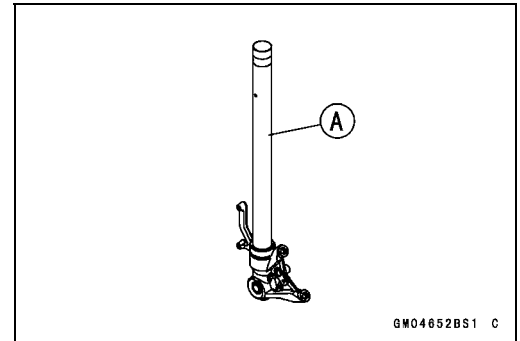

13-20 SUSPENSION

Rear Shock Absorber

Rebound Damping Force Adjustment

- To adjust the rebound damping force, turn the lower damping adjuster [A] to the desired position, until you feel a click.
- The standard adjuster setting is the **1 1/4 turns out** from the fully clockwise position.

Rebound Damping Force Adjustment

Adjuster Position	Damping Force	Setting	Load	Road	Speed
2 1/2 turns out	Weak	Soft	Light	Good	Low
↑	↑	↑	↑	↑	↑
↓	↓	↓	↓	↓	↓
0	Strong	Hard	Heavy	Bad	High

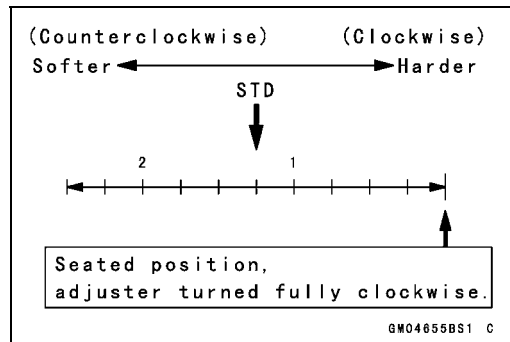
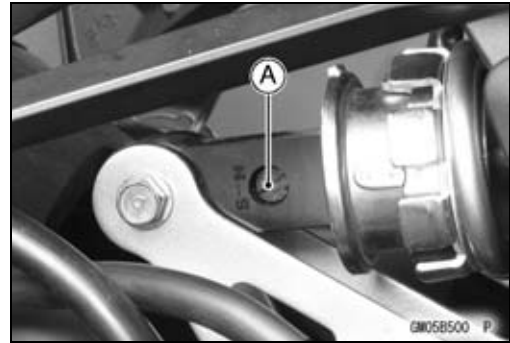

Spring Preload Adjustment

- Using the hook wrench [A], turn the adjusting ring [B] to adjust the spring preload.
- Special Tool - Hook Wrench T = 3.2 R37: 57001-1539**
- The standard adjusting ring is 4th step from the weakest position.

Spring Preload Setting

Standard Position: 4th position
Adjustable Range: 0 ~ 10th position

- ★ If the compression of the spring is not suited to the operating conditions, adjust it to an appropriate position by referring to the table below.

Spring Preload Adjustment

Adjuster Position	Damping Force	Shock Absorber Hardness	Load	Road Conditions	Driving Speed
0	Weak	Soft	Light	Good	Low
↑	↑	↑	↑	↑	↑
↓	↓	↓	↓	↓	↓
10th	Strong	Hard	Heavy	Bad	Highway

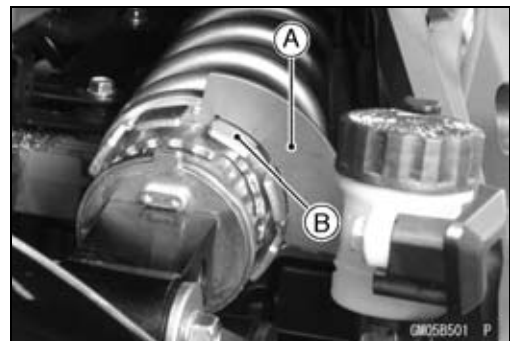

Rear Shock Absorber

Rear Shock Absorber Removal

- Support the motorcycle with the stand.
- Remove:
 - Bolts [A]
 - Sidestand Bracket [B] with the Sidestand
- Squeeze the brake lever slowly and hold it with a band [A].

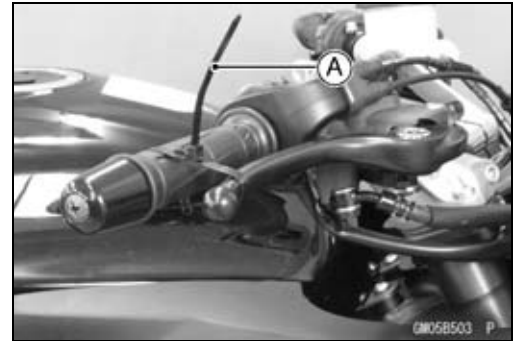
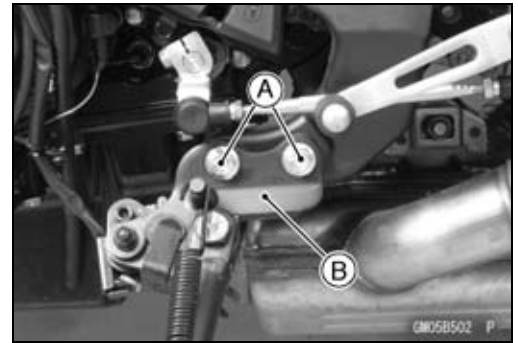

- Raise the rear wheel off the ground with the jack.
 - Special Tools - Jack [A]: 57001-1238
 - Jack Attachment [B]: 57001-1608

⚠ WARNING

Be sure to hold the front brake when removing the shock absorber, or the motorcycle may fall over. It could cause an accident and injury.

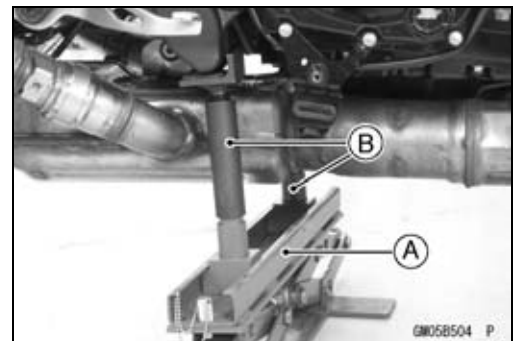

- Remove:
 - Lower Rear Shock Absorber Nut and Bolt [A]
 - Upper Rear Shock Absorber Bolt [B]
- Remove the rear shock absorber [C] from rearside.

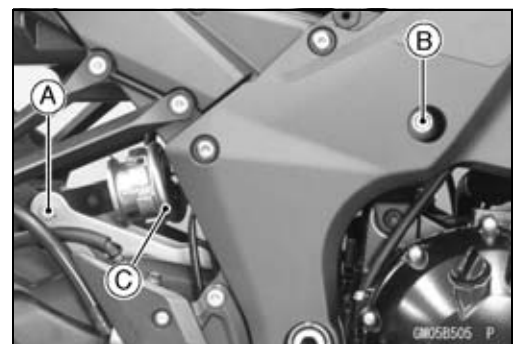

Rear Shock Absorber Installation

- Tighten:
 - Torque - Rear Shock Absorber Bolt and Nut (Upper and Lower): 34 N·m (3.5 kgf·m, 25 ft·lb)

13-22 SUSPENSION

Rear Shock Absorber

Rear Shock Absorber Inspection

- Remove the rear shock absorber (see Rear Shock Absorber Removal).
- Visually inspect the following items.
 - Smooth Stroke
 - Oil Leakage
 - Crack or Dent
- ★ If there is any damage to the rear shock absorber, replace it.
- Visually inspect the rubber bushing.
- ★ If it show any signs of damage, replace it.

Rear Shock Absorber Scrapping

⚠ WARNING

Since the rear shock absorber contains nitrogen gas, do not incinerate the rear shock absorber without first releasing the gas or it may explode. Before a rear shock absorber is scrapped, drill a hole at the point [A] shown to release the nitrogen gas completely. Wear safety glasses when drilling the hole, as the gas may blow out bits of drilled metal when the hole opens.

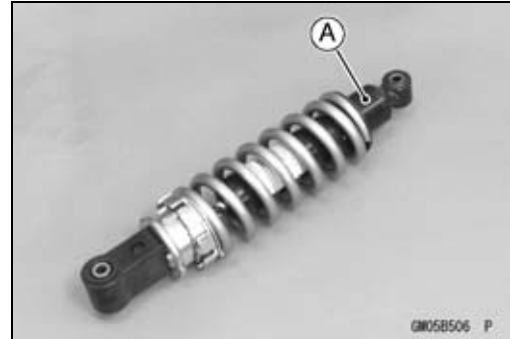

Rear Shock Absorber Bearing Removal

- Remove:
 - Rear Shock Absorber (see Rear Shock Absorber Removal)
 - Sleeve [A]
 - Grease Seals [B]

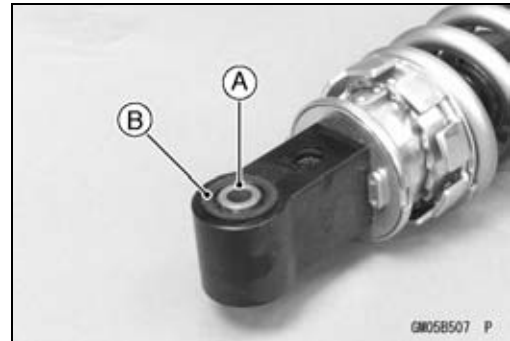

- Remove the needle bearing [A], using the bearing remover head [B] and bearing remover shaft [C].

Special Tools - Bearing Remover Head, $\phi 15 \times \phi 17$: 57001-1267

Bearing Remover Shaft $\phi 13$: 57001-1377

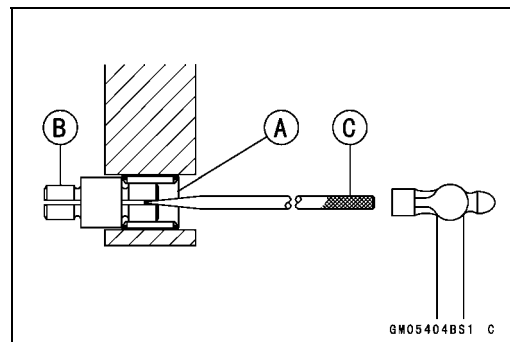

Rear Shock Absorber Bearing Installation

- Replace the needle bearing [A] and grease seals [B] with new ones.
- Apply plenty of grease to the lips of the grease seals.
- Install the needle bearing position as shown.
 - [C] 7.5 mm (0.30 in.)
- Install the grease seals and sleeve [D].

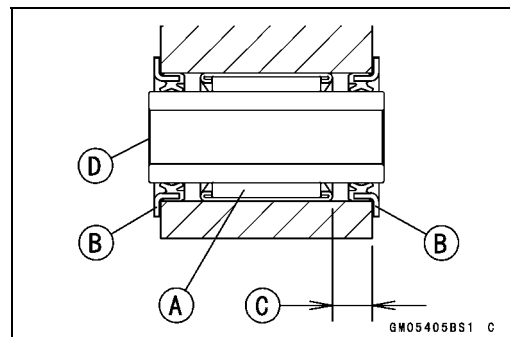

Swingarm

Swingarm Removal

- Remove:
 - Rear Brake Hose Lower End (see Rear Caliper Removal in the Brakes chapter)
 - Rear Wheel (see Rear Wheel Removal in the Wheels/Tires chapter)
 - Mud Guard (see Mud Guard Removal in the Frame chapter)
 - Rocker Arm (see Rocker Arm Removal)

- Remove:
 - Cotter Pin [A]
 - Bolt and Nut [B]
- Move the torque link [C] downward.

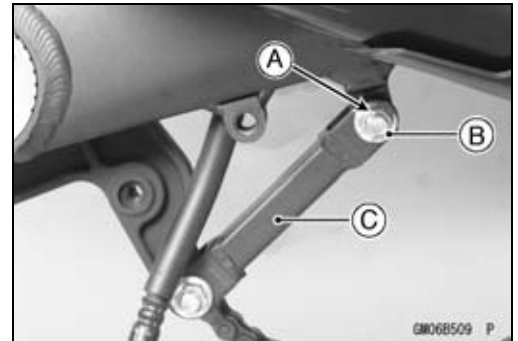

- Remove:
 - Brake Hose Clamp Bolt [A]
- Clear the brake hose [B] from the guide [C] on the swingarm.

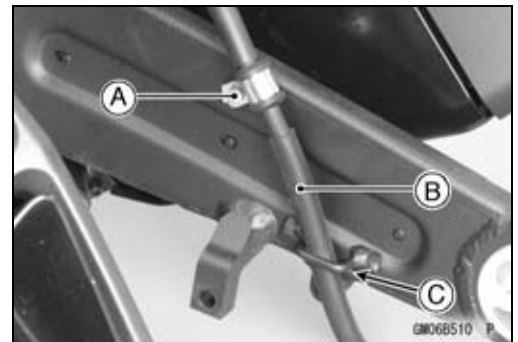

- Unscrew the swingarm pivot shaft nut [A].

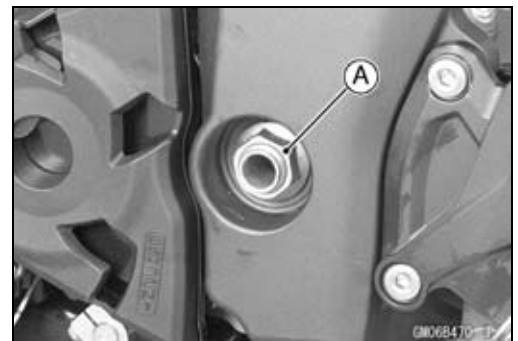

- Using the swingarm pivot nut wrench [A], loosen the swingarm pivot adjusting collar locknut [B].

Special Tool - Swingarm Pivot Nut Wrench: 57001-1597

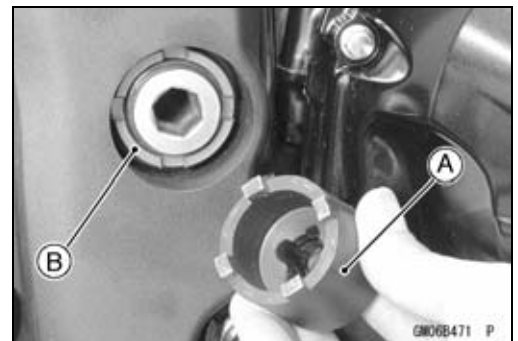

13-24 SUSPENSION

Swingarm

- Turn the swingarm pivot shaft [A] counterclockwise to free the adjusting collar from the swingarm.
- Make the gap between the adjusting collar and swingarm.
- Pull out the pivot shaft to the right side and remove the swingarm.

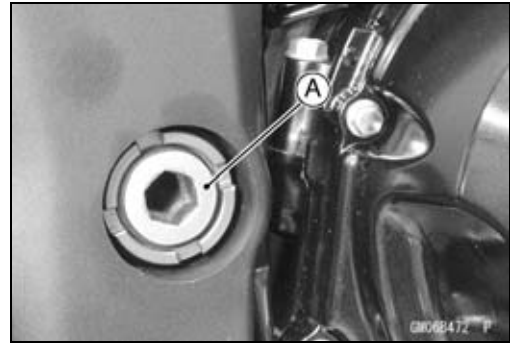

Swingarm Installation

- Visually inspect the chain guide [A].
- ★ Replace the chain guide if it shows any signs of abnormal wear or damage.

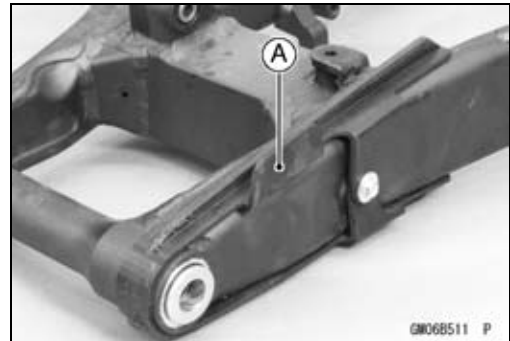

- Apply grease to the lips of the grease seals [A].
- Be sure to install the grease seals and sleeve [B] to the swingarm.
- Fit the collar [C] on the grease seal of the left side.

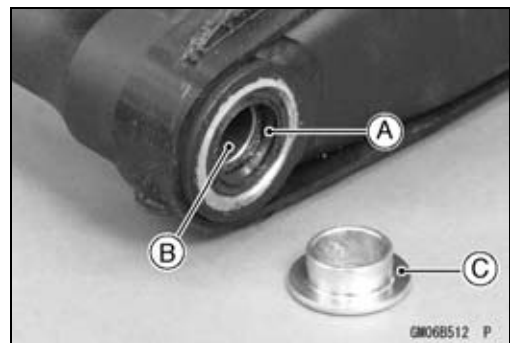

- Screw the swingarm pivot adjusting collar [A] into the frame [B] so that the collar does not project the swingarm mating surface [C].

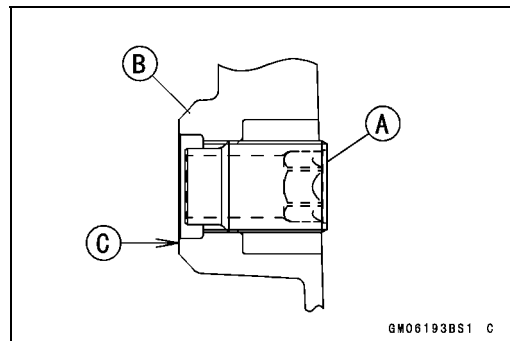

- Install the swingarm and insert the swingarm pivot shaft [A] into the adjusting collar [B] from the right side, and tighten the pivot shaft.

NOTE

- Tighten the swingarm pivot shaft until the clearance [C] between the ball bearing [D] and collar comes to 0 mm (0 in.).

Torque - Swingarm Pivot Shaft: 20 N·m (2.0 kgf·m, 15 ft·lb)

- Using the swingarm pivot nut wrench, tighten the swingarm pivot adjusting collar locknut [E].

Special Tool - Swingarm Pivot Nut Wrench: 57001-1597

Torque - Swingarm Pivot Adjusting Collar Locknut: 98 N·m (10 kgf·m, 72 ft·lb)

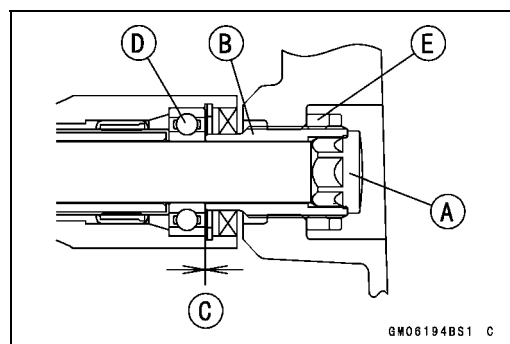

Swingarm

- Tighten the swingarm pivot shaft nut.
Torque - Swingarm Pivot Shaft Nut: 108 N-m (11.0 kgf-m, 79.7 ft-lb)
- Move the swingarm up and down to check for abnormal friction.
- Install the removed parts (see appropriate chapters).

Swingarm Bearing Removal

- Remove:
 - Swingarm (see Swingarm Removal)
 - Collar [A]
 - Grease Seals [B]
 - Sleeve [C]
 - Circlip (Right Side) [D]
- Special Tool - Inside Circlip Pliers: 57001-143**

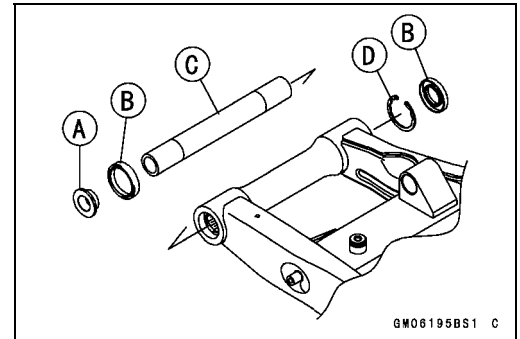

- Remove the ball bearing and needle bearings.
Special Tool - Oil Seal & Bearing Remover [A]: 57001-1058

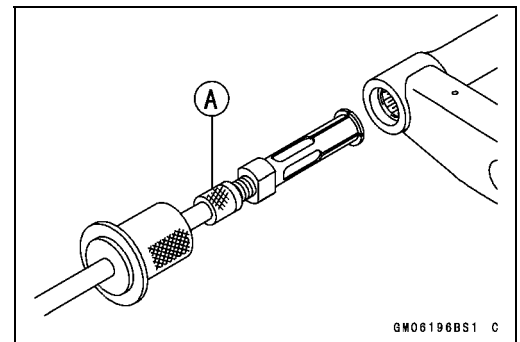

Swingarm Bearing Installation

- Replace the needle bearings [A], ball bearing [B], grease seals [C] and circlip [D] with new ones.
- Install the needle bearings as shown in the figure.
 - [E] Left Side
 - [F] Right Side
 - [G] 27 mm (1.1 in.)
 - [H] 9.5 mm (0.37 in.)
 - [I] 29.5 mm (1.16 in.)

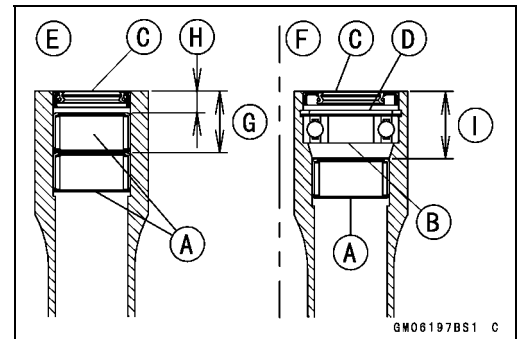

NOTE

○ Install the needle bearings so that the marked side faces out.

Special Tool - Needle Bearing Driver, ϕ 28: 57001-1610

- Press in the ball bearing until it bottomed.
Special Tool - Bearing Driver Set: 57001-1129
- Install the circlip.
Special Tool - Inside Circlip Pliers: 57001-143
- Press in the grease seals so that seal surface is flushed with the end of housing.
Special Tool - Bearing Driver Set: 57001-1129

13-26 SUSPENSION

Swingarm

Swingarm Bearing, Sleeve Inspection

NOTICE

Do not remove the bearings for inspection. Removal may damage them.

- Inspect the needle bearings [A] and ball bearing [B] installed in the swingarm.
- The rollers and ball in a bearing normally wear very little, and wear is difficult to measure. Instead of measuring, visually inspect the bearing for abrasion, discoloration, or other damage.
- ★ If the needle bearing and sleeve [C] show any signs of abnormal wear, discoloration, or damage, replace them as a set.

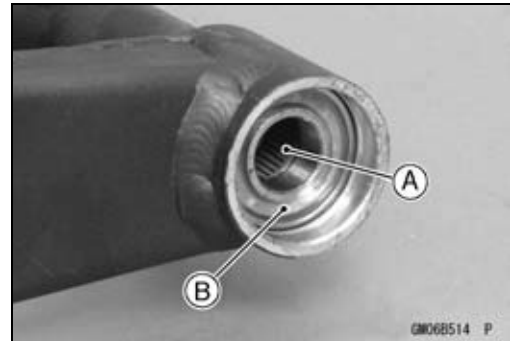
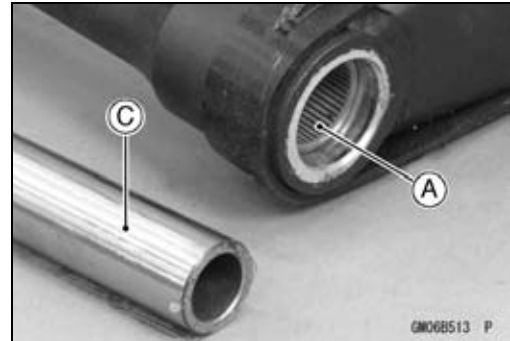

- Turn the bearing in the swingarm back and forth [A] while checking for plays, roughness, or binding.
- ★ If bearing play, roughness, or binding is found, replace the bearing.
- Examine the bearing seal [B] for tears or leakage.
- ★ If the seal is torn or is leaking, replace the bearing.

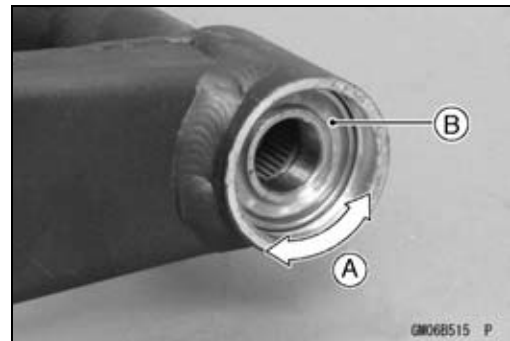

Swingarm Bearing Lubrication

NOTE

- Since the bearings are packed with grease and sealed, lubrication is not required.

Chain Guide Inspection

- Refer to the Chain Guide Wear Inspection in the Periodic Maintenance chapter.

Tie-Rod, Rocker Arm

Tie-Rod Removal

- Remove:
 - Mud Guard (see Mud Guard Removal in the Frame chapter)
- Squeeze the brake lever slowly and hold it with a band [A].

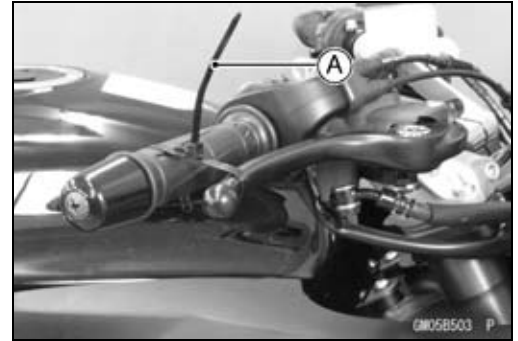

- Raise the rear wheel off the ground with the jack (see Rear Shock Absorber Removal).

Special Tools - Jack: 57001-1238

Jack Attachment: 57001-1608

- Remove:
 - Upper Tie-Rod Bolt and Nut [A]
 - Lower Tie-Rod Bolt and Nut [B]
 - Tie-Rod [C]

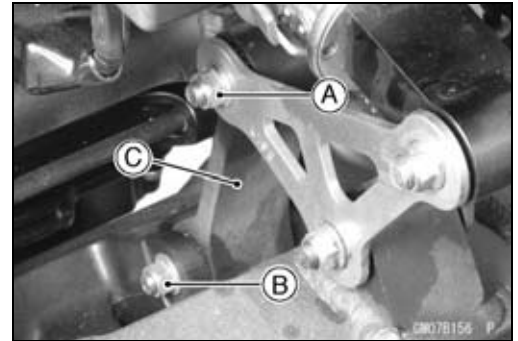

Tie-Rod Installation

- Apply grease to the inside of the grease seals.
- Install the tie-rod.
- Replace the tie-rod nuts with new ones.
- Tighten:
 - Torque - Tie-Rod Nuts: 34 N-m (3.5 kgf-m, 25 ft-lb)**

Rocker Arm Removal

- Remove:
 - Mud Guard (see Mud Guard Removal in the Frame chapter)
- Squeeze the brake lever slowly and hold it with a band.
- Raise the rear wheel off the ground with the jack (see Rear Shock Absorber Removal).

Special Tools - Jack: 57001-1238

Jack Attachment: 57001-1608

- Remove:
 - Lower Rear Shock Absorber Bolt and Nut [A]
 - Upper Tie-Rod Bolt and Nut [B]
 - Rocker Arm Bolt and Nut [C]
 - Rocker Arms [D]

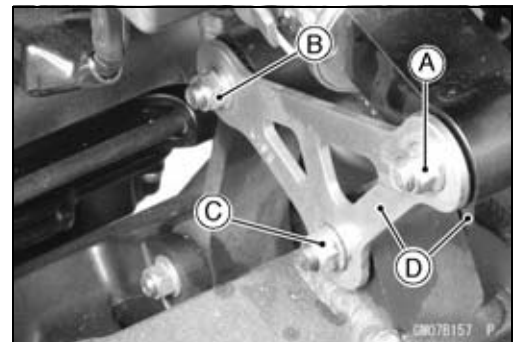

Rocker Arm Installation

- Apply grease to the inside of the oil seals.
- Replace the rocker arm nut and rear shock absorber nut respective new one.
- Tighten:
 - Torque - Rocker Arm Nut: 34 N-m (3.5 kgf-m, 25 ft-lb)**
 - Tie-Rod Nuts: 34 N-m (3.5 kgf-m, 25 ft-lb)**
 - Rear Shock Absorber Nut (Lower): 34 N-m (3.5 kgf-m, 25 ft-lb)**
- Install the removed parts (see appropriate chapters).

13-28 SUSPENSION

Tie-Rod, Rocker Arm

Tie-Rod and Rocker Arm Bearing Removal

- Remove:
 - Tie-Rods (see Tie-Rod Removal)
 - Rocker Arm (see Rocker Arm Removal)
 - Sleeves [A]
 - Oil Seals [B]
 - Swingarm [C] (see Swingarm Removal)
- Remove the needle bearings [D], using the bearing remover head and bearing remover shaft.

Special Tools - Bearing Remover Head, $\phi 15 \times \phi 17$: 57001-1267
Bearing Remover Shaft, $\phi 13$: 57001-1377

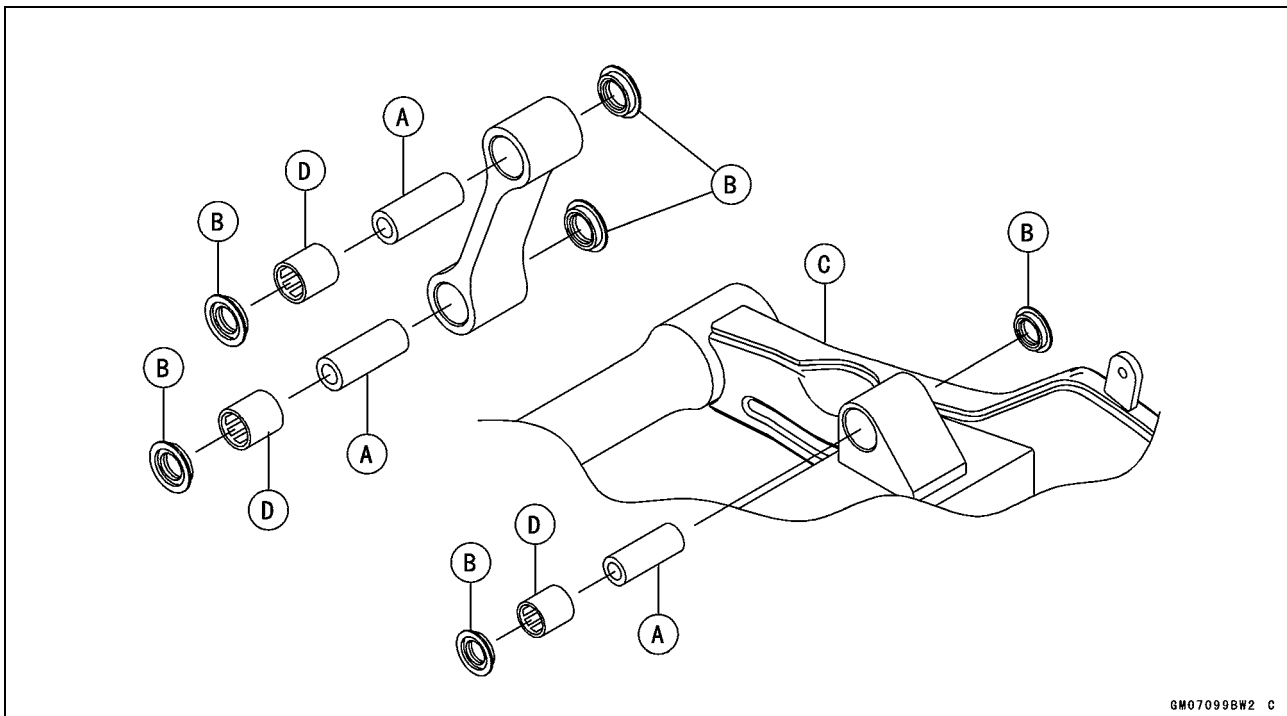

Tie-Rod and Rocker Arm Bearing Installation

- Replace the needle bearing [A] and oil seals with new ones.
- Apply plenty of grease to the lips of the oil seals.
- Install the needle bearings and oil seals position as shown in the figure.
- Screw the needle bearing driver into the driver holder.
- Insert the needle bearing driver into the needle bearing and press the needle bearing.
7.5 mm (0.30 in.) [B]

NOTE

- For a bearing of inner diameter $\phi 17$, select the pressing side of the needle bearing driver according to its pressing depth.

Special Tools - Bearing Driver Set: 57001-1129
Needle Bearing Driver, $\phi 17/\phi 18$: 57001-1609

NOTE

- Install the needle bearings so that the marked side faces in.

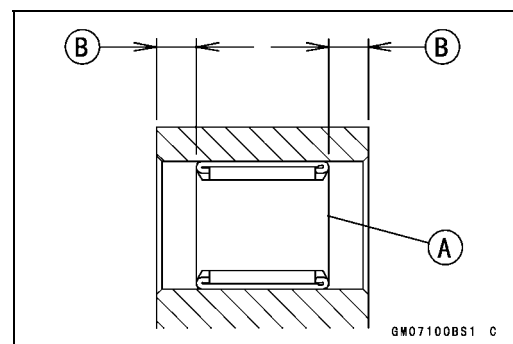

Tie-Rod, Rocker Arm

Rocker Arm/Tie-Rod Bearing, Sleeve Inspection**NOTICE**

Do not remove the bearings for inspection. Removal may damage them.

- Visually inspect the rocker arm, or tie-rod sleeves [A] and needle bearings [B].
- The rollers in a needle bearing normally wear very little, and wear is difficult to measure. Instead of measuring, inspect the bearing for abrasion, color change, or other damage.
- ★ If there is any doubt as to the condition of any of the needle bearings or sleeve, replace the sleeve and needle bearings as a set.

Rocker Arm/Tie-Rod Bearing Lubrication**NOTE**

- Since the bearings are packed with grease, lubrication is not required.

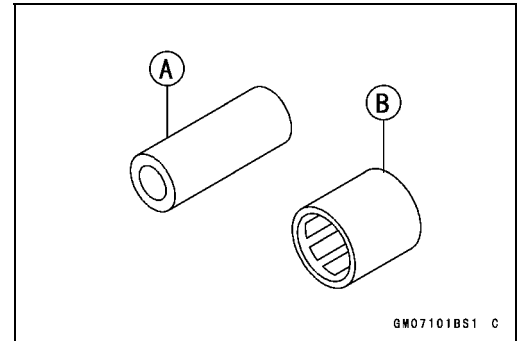

Steering

Table of Contents

Exploded View.....	14-2
Special Tools	14-4
Steering	14-5
Steering Inspection	14-5
Steering Adjustment.....	14-5
Steering Stem.....	14-6
Stem, Stem Bearing Removal.....	14-6
Stem, Stem Bearing Installation.....	14-7
Steering Stem Bearing Lubrication	14-8
Steering Stem Warp.....	14-9
Stem Cap Deterioration, Damage.....	14-9
Handlebar	14-10
Handlebar Removal	14-10
Handlebar Installation	14-10

14-2 STEERING

Exploded View

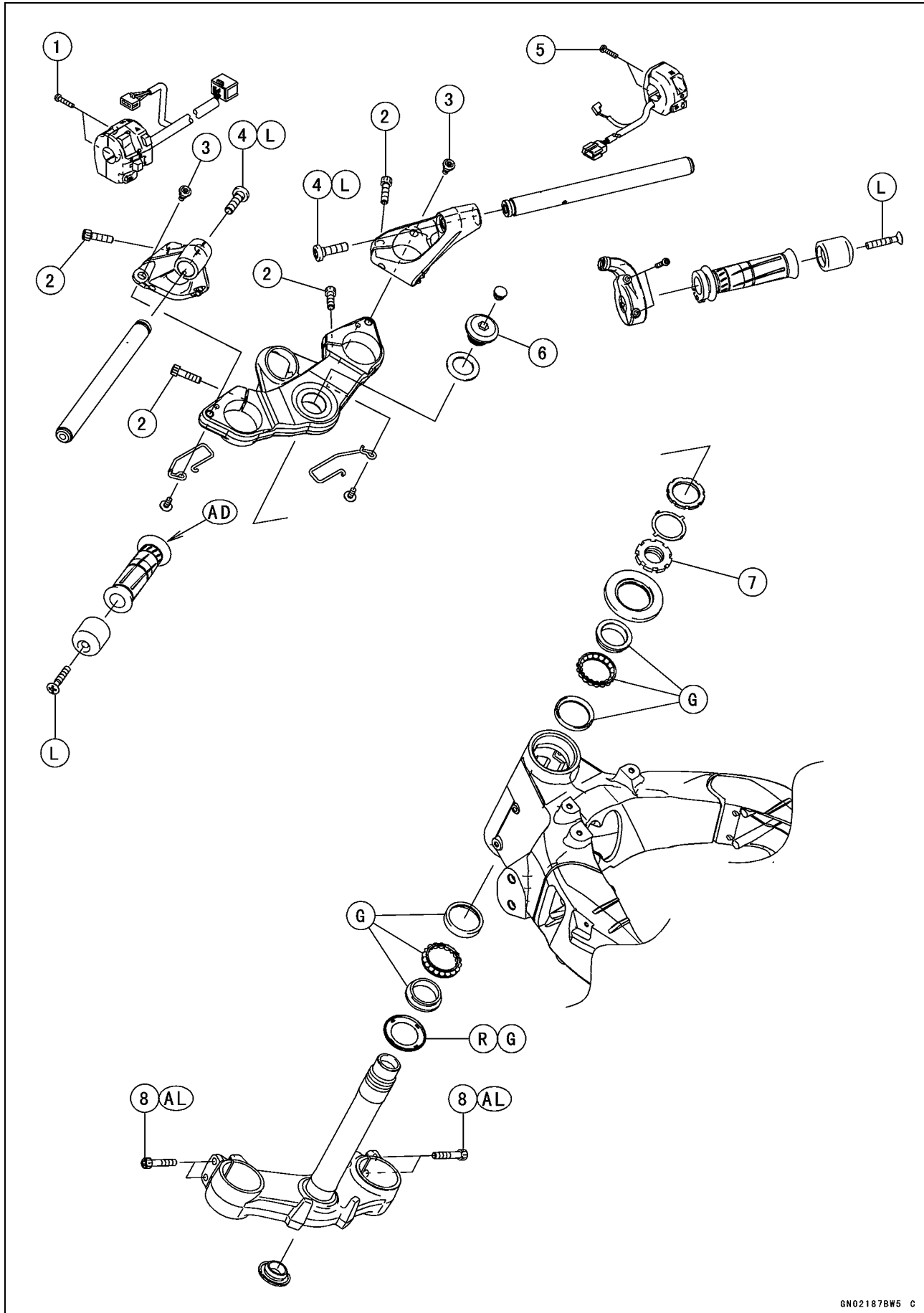

Exploded View

No.	Fastener	Torque			Remarks
		N·m	kgf·m	ft·lb	
1	Left Switch Housing Screws	3.5	0.36	31 in·lb	
2	Upper Front Fork Clamp Bolts	25	2.5	18	
3	Handlebar Holder Bolts	25	2.5	18	
4	Handlebar Bolts	34	3.5	25	L
5	Right Switch Housing Screws	3.5	0.36	31 in·lb	
6	Steering Stem Head Bolt	108	11.0	79.7	
7	Steering Stem Nut	25	2.5	18	
8	Lower Front Fork Clamp Bolts	20	2.0	15	AL

AD: Apply adhesive.

AL: Tighten the two clamp bolts alternately two times to ensure even tightening torque.

G: Apply grease.

R: Replacement Parts

L: Apply a non-permanent locking agent.

14-4 STEERING

Special Tools

Head Pipe Outer Race Press Shaft:
57001-1075

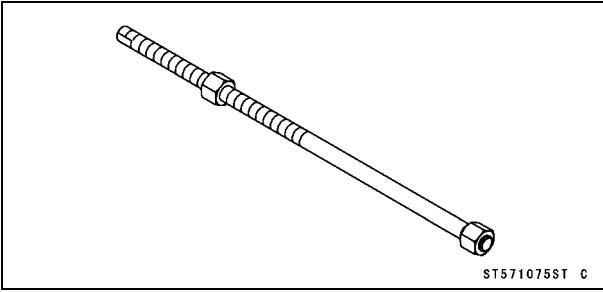

Head Pipe Outer Race Driver, ϕ 54.5:
57001-1077

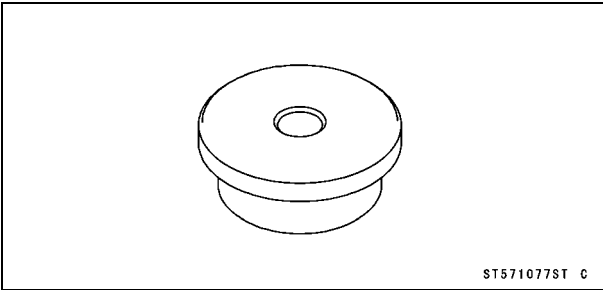

Steering Stem Nut Wrench:
57001-1100

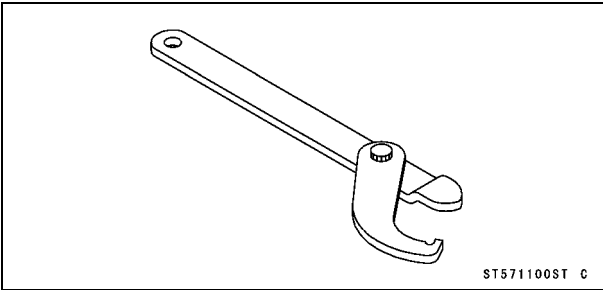

Steering Stem Bearing Driver, ϕ 42.5:
57001-1344

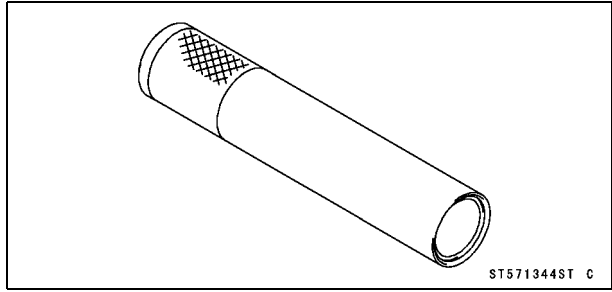

Steering Stem Bearing Driver Adapter, ϕ 41.5:
57001-1345

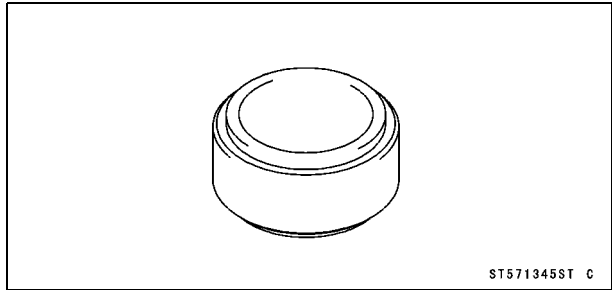

Head Pipe Outer Race Driver, ϕ 55:
57001-1446

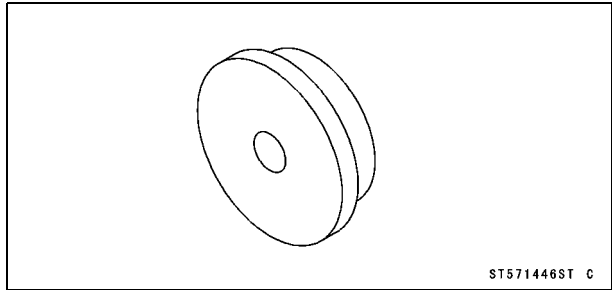

Steering

Steering Inspection

- Refer to the Steering Play Inspection in the Periodic Maintenance chapter.

Steering Adjustment

- Refer to the Steering Play Adjustment in the Periodic Maintenance chapter.

14-6 STEERING

Steering Stem

Stem, Stem Bearing Removal

- Remove:
 - Upper Fairing (see Upper Fairing Removal in the Frame chapter)
 - Upper Fairing Bracket (see Upper Fairing Bracket Removal in the Frame chapter)
 - Meter Unit (see Meter Unit Removal in the Electrical System chapter)
 - Handlebar (see Handlebar Removal)
 - Steering Stem Head Bolt Plug [A]
 - Steering Stem Head Bolt [B] and Washer

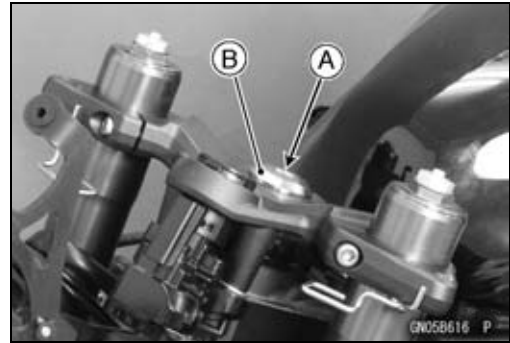

- Remove:
 - Front Forks (see Handlebar Removal in the Suspension chapter)
 - Steering Stem Head
 - Brake Hose Fitting Bolt [A]



- Bend the claws [A] of claw washer back.
- Remove the steering stem locknut [B].
 - Special Tool - Steering Stem Nut Wrench: 57001-1100**
- Remove the claw washer.

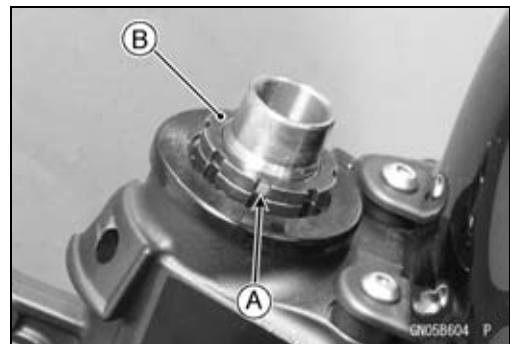

- Pushing up the stem base, and remove the steering stem nut [A] with stem cap [B].

Special Tool - Steering Stem Nut Wrench [C]: 57001-1100

- Remove:
 - Steering Stem [D]
 - Upper Ball Bearing Inner Race and Ball Bearing

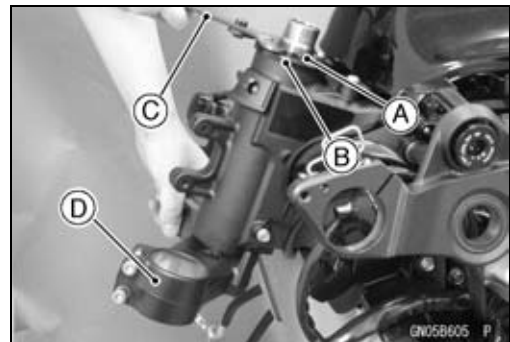

- To remove the ball bearing outer races [A] pressed into the head pipe [B], insert a bar [C] into the recesses of head pipe, and applying it to both recess alternately hammer it to drive the race out.

NOTE

- If either steering stem bearing is damaged, it is recommended that both the upper and lower bearings (including outer races) should be replaced with new ones.

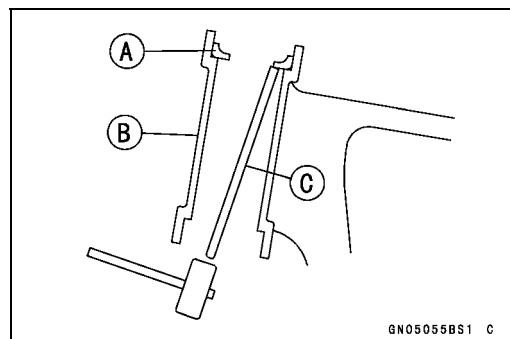

GN05055BS1 C

Steering Stem

- Remove the lower ball bearing inner race (with its oil seal) [A] which is pressed onto the steering stem with a suitable commercially available chisel [B].

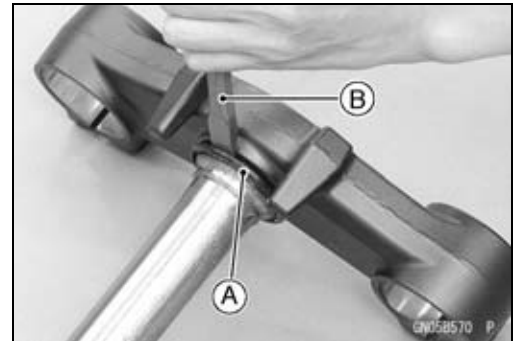

Stem, Stem Bearing Installation

- Replace the bearing outer races with new ones.
- Drive them into the head pipe at the same time.

Special Tools - Head Pipe Outer Race Press Shaft [A]:
57001-1075

Head Pipe Outer Race Driver, $\phi 54.5$ [B]:
57001-1077

Head Pipe Outer Race Driver, $\phi 55$: 57001-1446

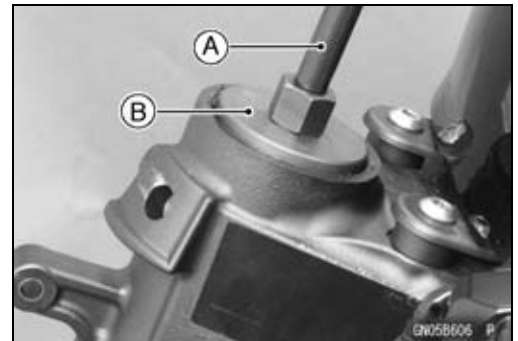

- Apply grease to the outer races.
- Replace the bearing inner races and oil seal with new ones.
- Apply grease to the oil seal.
- Install the oil seal [A] on the steering stem, and drive the lower ball bearing inner race [B] applied the grease onto the stem.

Special Tools - Steering Stem Bearing Driver, $\phi 42.5$ [C]:
57001-1344

Steering Stem Bearing Driver Adapter, $\phi 41.5$ [D]: 57001-1345

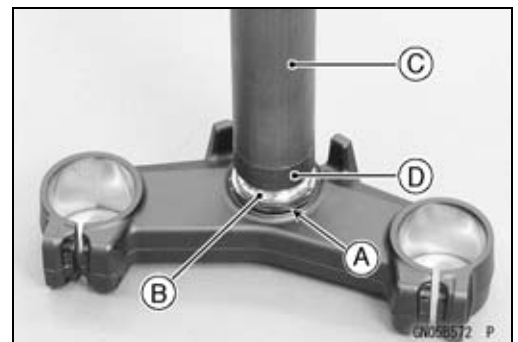

- Install the lower ball bearing [A] onto the stem.
- Grease the following.
 - Inner and Outer Races
 - Lower and Upper Ball Bearings
- The lower and upper ball bearings are identical.

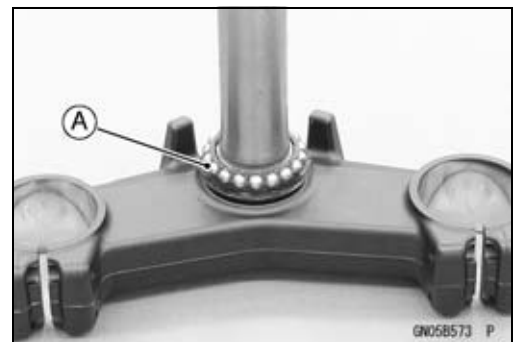

- Install the stem [A] through the head pipe and install the ball bearing [B] and inner race [C] on it.
- Install:
 - Stem Cap [D]
 - Steering Stem Nut [E]

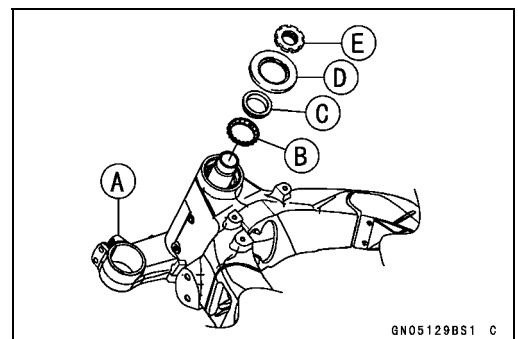

14-8 STEERING

Steering Stem

- Settle the bearings in place as follows.
- Tighten the steering stem nut with **55 N·m (5.6 kgf·m, 41 ft·lb)** of torque first, and loosen it a fraction of a turn until it turns lightly. Afterward tighten it again with specified torque using a steering stem nut wrench [A].

Special Tool - Steering Stem Nut Wrench: 57001-1100

Torque - Steering Stem Nut: 25 N·m (2.5 kgf·m, 18 ft·lb)

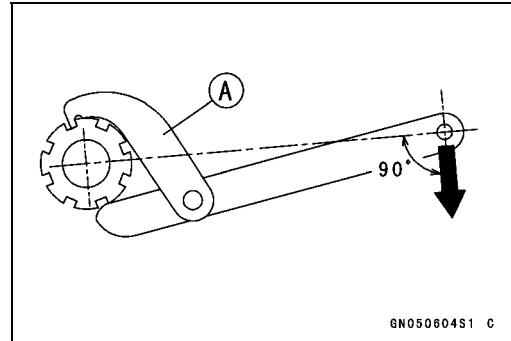

- Install the claw washer [A] so that its bent side [B] faces upward, and engage the bent claws with the grooves of stem locknut [C].
- Hand tighten the stem locknut until the claw washer touches the steering stem nut.
- Tighten the stem locknut clockwise until the claws are aligned with the grooves (ranging from 2nd to 4th) of stem nut [D], and bend the 2 claws downward [E].
- Install the stem head.
- Install the washer, and temporary tighten the steering stem head bolt.
- Install the front forks (see Front Fork Installation in the Suspension chapter).

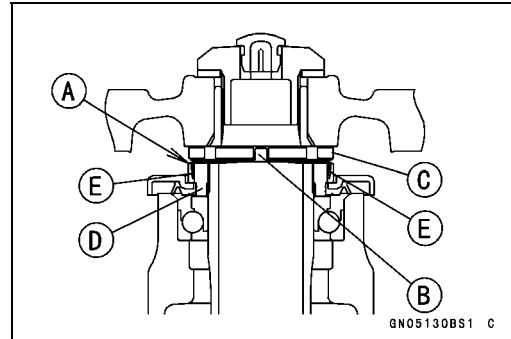

NOTE

- Tighten the lower front fork clamp bolts first, next the stem head bolt, last the upper front fork clamp bolts.
- Tighten the front fork clamp bolts (upper and lower) alternately two times to ensure even tightening torque.

Torque - Upper Front Fork Clamp Bolts: 25 N·m (2.5 kgf·m, 18 ft·lb)

Steering Stem Head Bolt: 108 N·m (11.0 kgf·m, 79.7 ft·lb)

Lower Front Fork Clamp Bolts: 20 N·m (2.0 kgf·m, 15 ft·lb)

WARNING

If the handlebar does not turn to the steering stop it may cause an accident resulting in injury or death. Be sure the cables, harnesses and hoses are routed properly and do not interfere with handlebar movement (see Cable, Wire, and Hose Routing section in the Appendix chapter).

- Install the removed parts (see appropriate chapters).

Steering Stem Bearing Lubrication

- Refer to the Steering Stem Bearing Lubrication in the Periodic Maintenance chapter.

Steering Stem

Steering Stem Warp

- Whenever the steering stem is removed, or if the steering can not be adjusted for smooth action, check the steering stem for straightness.
- ★ If the steering stem [A] is bent, replace the steering stem.

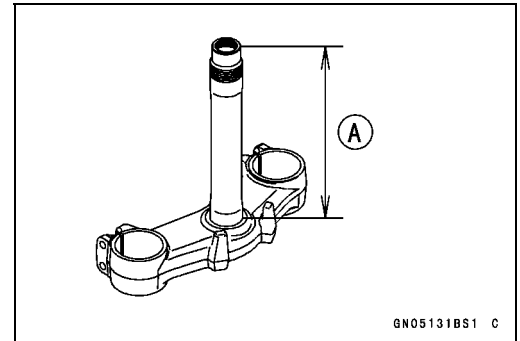

Stem Cap Deterioration, Damage

- ★ Replace the stem cap if its oil seal [A] shows damage.



14-10 STEERING

Handlebar

Handlebar Removal

- Remove:
 - Clutch Lever Clamp Bolts [A]
 - Clutch Lever Assembly [B]
 - Left Switch Housing [C]
 - Handlebar Weight [D]

- Remove:
 - Front Master Cylinder [A] (see Front Master Cylinder Removal in the Brakes chapter)
 - Right Switch Housing [B]
 - Throttle Case [C]
 - Handlebar Weight [D]
 - Throttle Grip [E]

- Remove:
 - Handlebar Bolt [A]
 - Handlebar

- Loosen the upper front fork clamp bolt [A].
- Remove:
 - Handlebar Holder Bolt [B]
 - Handlebar Holder [C]

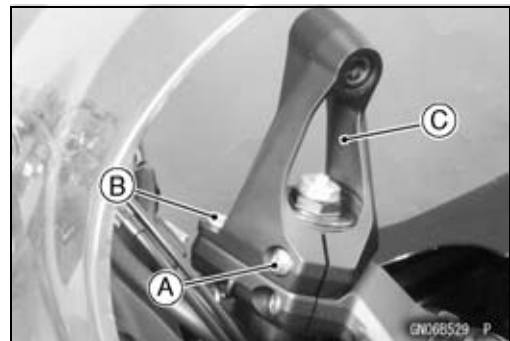
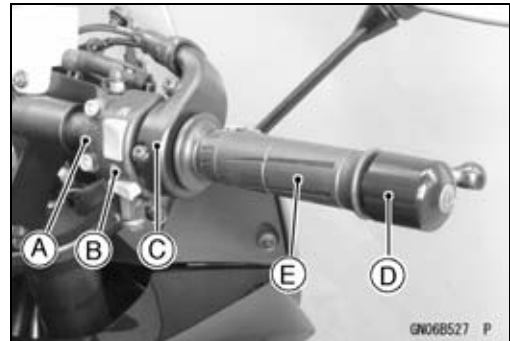
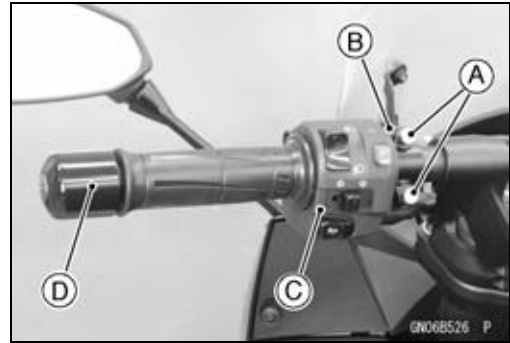

Handlebar Installation

- Install the handlebar holder on the steering stem head.
 - Tighten the handlebar holder bolt [A] and front fork clamp bolt [B].
- Torque - Handlebar Holder Bolt: 25 N·m (2.5 kgf·m, 18 ft·lb)**
Upper Front Fork Clamp Bolt: 25 N·m (2.5 kgf·m, 18 ft·lb)

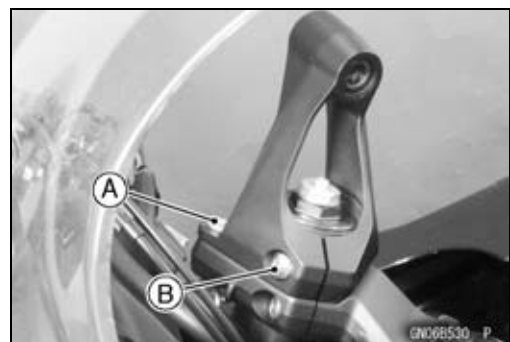

Handlebar

- Apply adhesive cement to the inside of the left handlebar grip.
- Fit the pin [A] of the handlebar to the recess [B] of the handlebar holder.
- Apply a non-permanent locking agent to the threads of the handlebar bolts.
- Tighten:

Torque - Handlebar Bolts: 34 N·m (3.5 kgf·m, 25 ft·lb)

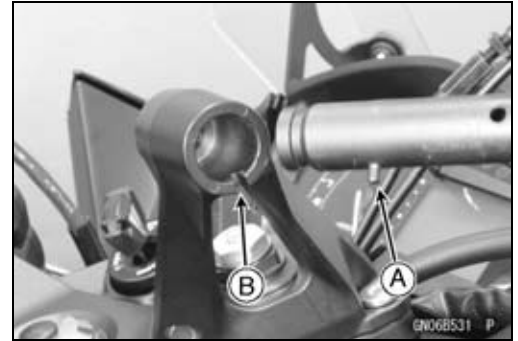

- Install:
 - Front Master Cylinder (see Front Master Cylinder Installation in the Brake chapter)
 - Throttle Grip
 - Throttle Cable Tips [A]
 - Throttle Cases [B]
- Fit the projection [C] into a hole [D] in the handlebar.
- Apply a non-permanent locking agent to the threads of the handlebar weight bolts, and tighten them.

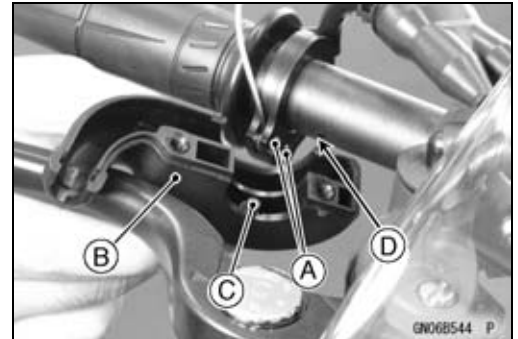

- Install the clutch lever (see Clutch Lever Installation in the Clutch chapter).
- Install the left and right switch housings.
- Fit the projection [A] into a hole [B] in the handlebar.

Torque - Switch Housing Screws: 3.5 N·m (0.36 kgf·m, 31 in·lb)

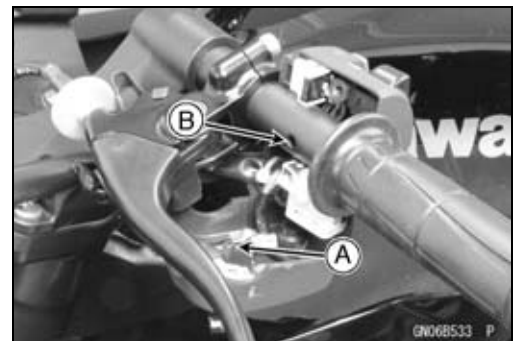

Frame

Table of Contents

Exploded View.....	15-2	Side Cover Installation.....	15-19
Seats	15-8	Left Lower Side Fairing Removal..	15-19
Rear Seat Removal.....	15-8	Left Lower Side Fairing	
Rear Seat Installation.....	15-8	Installation.....	15-19
Front Seat Removal.....	15-8	Seat Covers.....	15-20
Front Seat Installation.....	15-8	Seat Cover Removal.....	15-20
Fairings.....	15-9	Seat Cover Installation.....	15-20
Lower Fairing Removal.....	15-9	Fenders	15-21
Lower Fairing Installation.....	15-10	Front Fender Removal.....	15-21
Lower Fairing Disassembly.....	15-11	Front Fender Installation.....	15-21
Lower Fairing Assembly.....	15-12	Flap and Rear Fender Removal...	15-21
Rear Lower Fairing Removal.....	15-13	Flap and Rear Fender Installation	15-22
Rear Lower Fairing Installation....	15-13	Frame	15-23
Windshield Removal.....	15-13	Frame Inspection.....	15-23
Windshield Installation.....	15-13	Rear Frame Removal.....	15-23
Upper Fairing Removal.....	15-13	Rear Frame Installation.....	15-23
Upper Fairing Installation.....	15-14	Rear Frame Bracket Removal.....	15-23
Upper Fairing Disassembly.....	15-15	Rear Frame Bracket Installation..	15-23
Upper Fairing Assembly.....	15-15	Battery Case.....	15-24
Windshield Bracket Disassembly..	15-15	Battery Case Removal.....	15-24
Windshield Bracket Assembly.....	15-16	Battery Case Installation.....	15-24
Windshield Bracket Assembly		Guard.....	15-25
Removal.....	15-18	Mud Guard Removal.....	15-25
Windshield Bracket Assembly		Mud Guard Installation.....	15-25
Installation.....	15-18	Sidestand.....	15-26
Side Covers.....	15-19	Sidestand Removal.....	15-26
Side Cover Removal.....	15-19	Sidestand Installation.....	15-26

15-2 FRAME

Exploded View

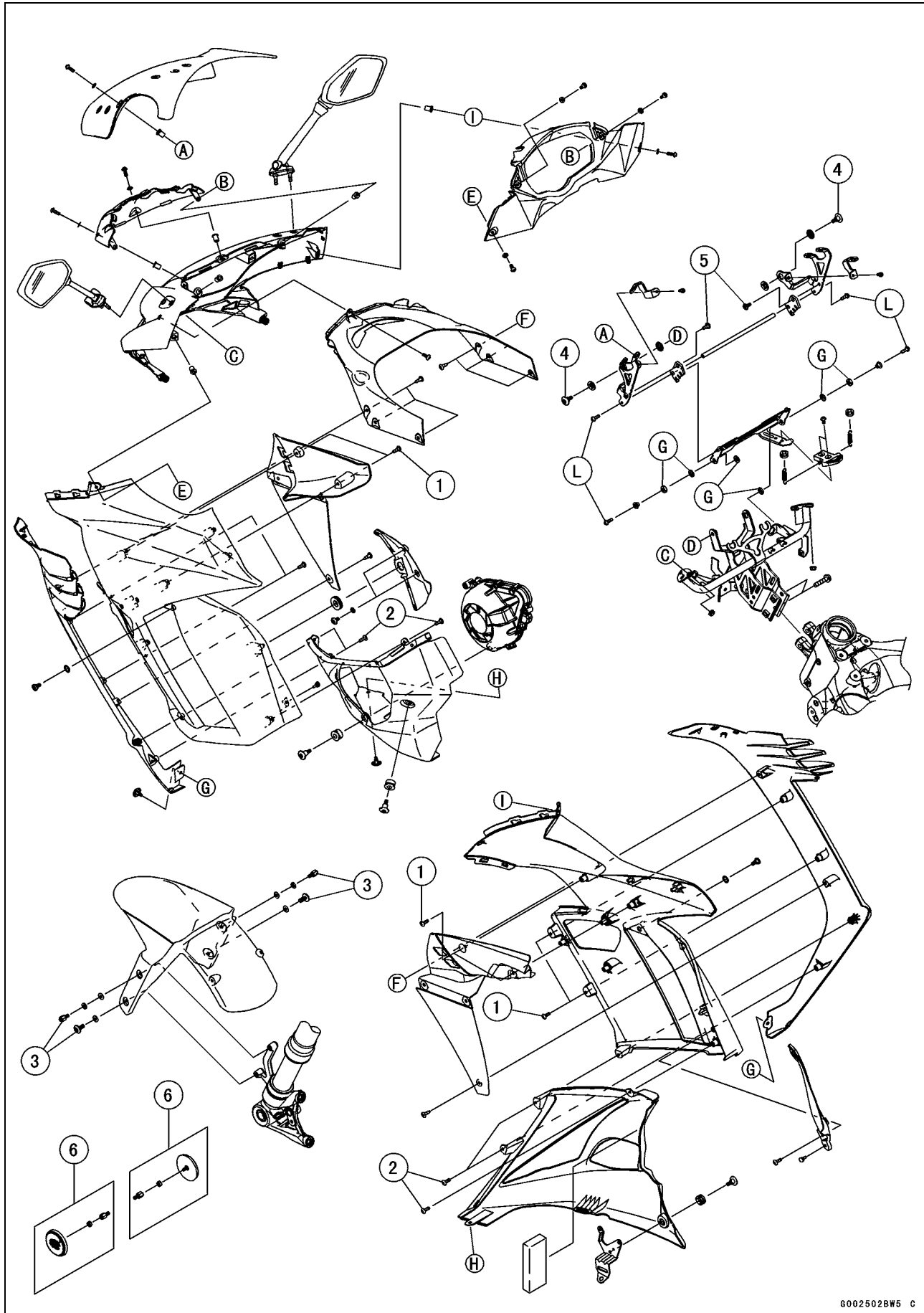

Exploded View

No.	Fastener	Torque			Remarks
		N·m	kgf·m	ft·lb	
1	Lower Fairing Upper Assembly Screws	1.2	0.12	11 in·lb	
2	Lower Fairing Lower Assembly Screws	1.2	0.12	11 in·lb	
3	Front Fender Mounting Bolts	3.9	0.40	35 in·lb	
4	Stay Assembly Mounting Bolts	6.9	0.70	61 in·lb	
5	Stopper Mounting Bolts	4.2	0.42	37 in·lb	

6. US, CA and CAL Models

G. Apply grease.

L: Apply a non-permanent locking agent.

15-4 FRAME

Exploded View

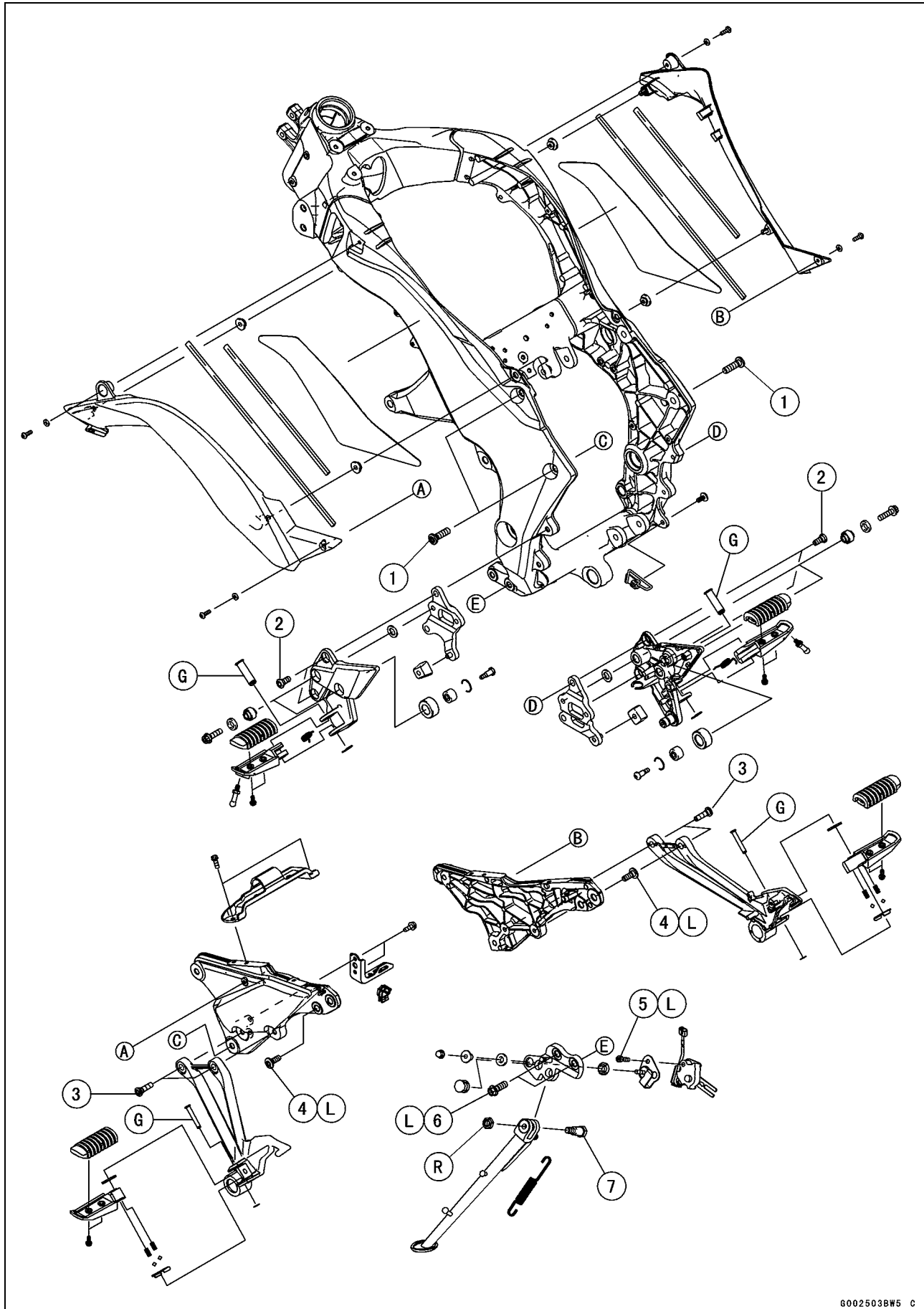

Exploded View

No.	Fastener	Torque			Remarks
		N·m	kgf·m	ft·lb	
1	Rear Frame Bracket Bolts	44	4.5	32	
2	Front Footpeg Bracket Bolts	25	2.5	18	
3	Rear Footpeg Bracket Bolts	25	2.5	18	
4	Rear Frame Bolts	25	2.5	18	L
5	Sidestand Switch Bolt	8.8	0.90	78 in·lb	L
6	Sidestand Bracket Bolts	49	5.0	36	L
7	Sidestand Bolt	44	4.5	32	

G: Apply grease.

L: Apply a non-permanent locking agent.

R: Replacement Parts

15-6 FRAME

Exploded View

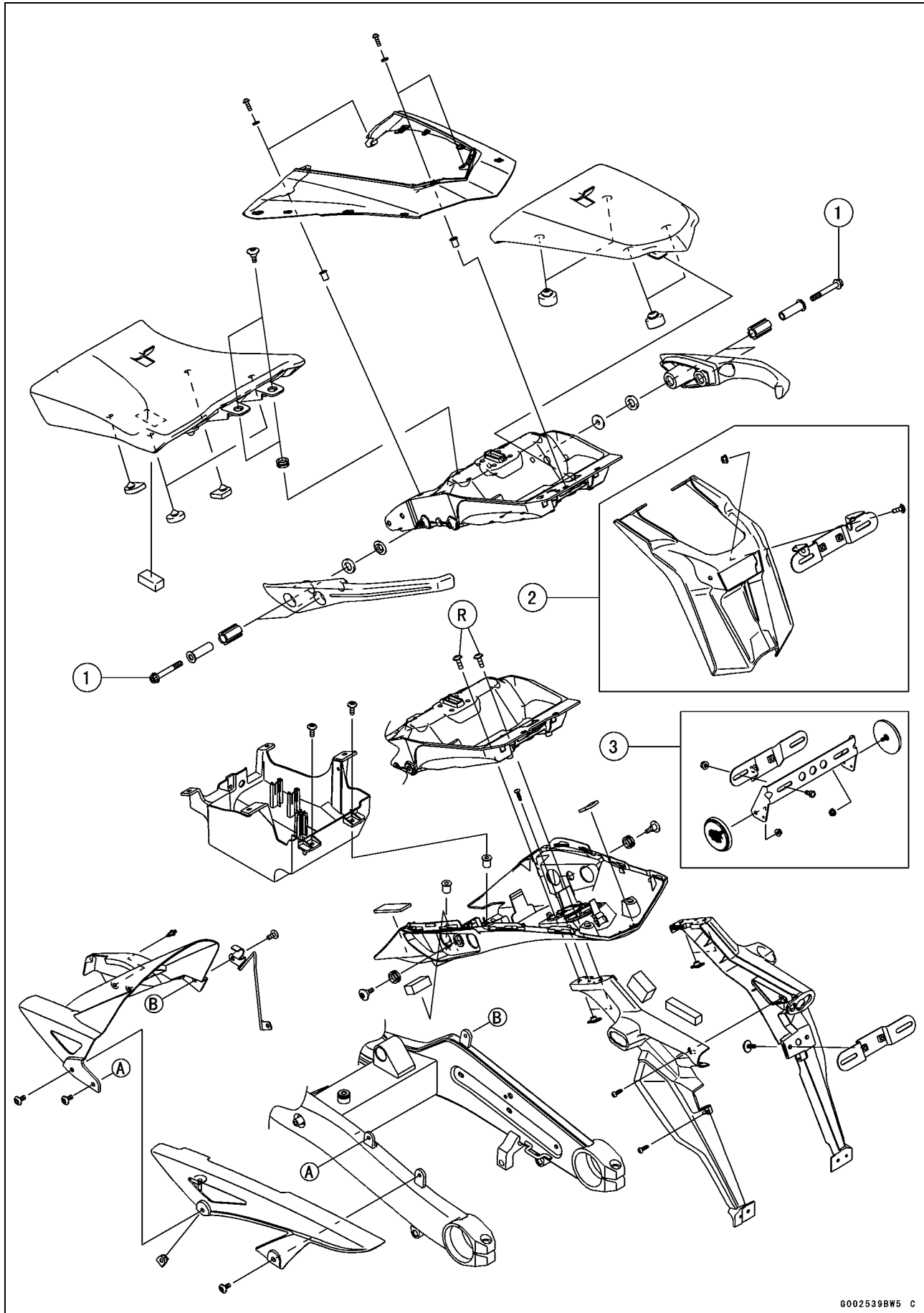

Exploded View

No.	Fastener	Torque			Remarks
		N·m	kgf·m	ft·lb	
1	Grab Rail Mounting Bolts	25	2.5	18 ft·lb	

- 2. AT Model
- 3. US, CA, and CAL Models
- R: Replacement Parts

15-8 FRAME

Seats

Rear Seat Removal

- Insert the ignition switch key [A] into the seat lock, turning the key clockwise, pulling the front part of the seat [B] up, and pull the seat forward.

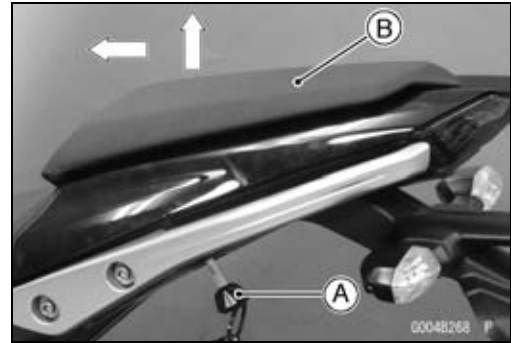

Rear Seat Installation

- Insert the rear seat hook [A] under the rear frame [B].
- Insert the seat hook [C] into the latch hole [D].
- Push down the front part of the seat until the lock clicks.

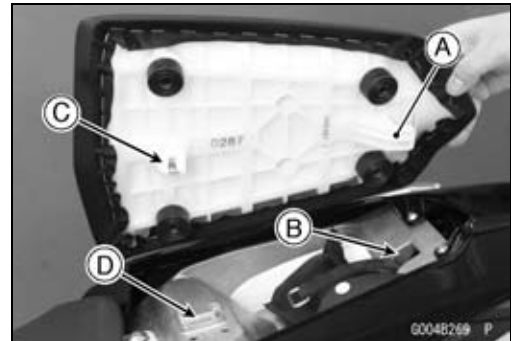

Front Seat Removal

- Remove the rear seat (see Rear Seat Removal).
- Remove the front seat bolts [A], and then remove the front seat [B] by pulling the rear of it up and backward.

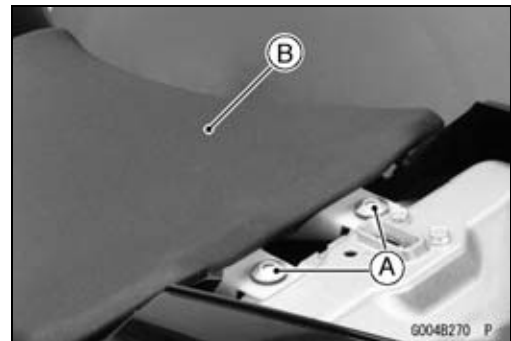

Front Seat Installation

- Insert the front seat hooks [A] under the brace of the fuel tank bracket [B].
- Install the front seat bolts.

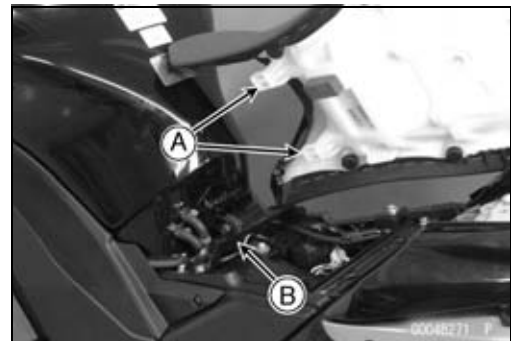

Fairings

Lower Fairing Removal

- Remove:

- Quick Rivets [A]

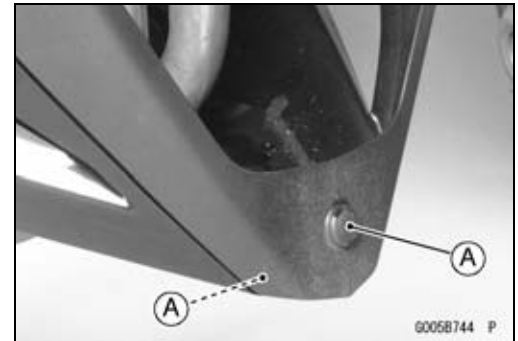

- Remove:

- Quick Rivets [A] (Both Sides)

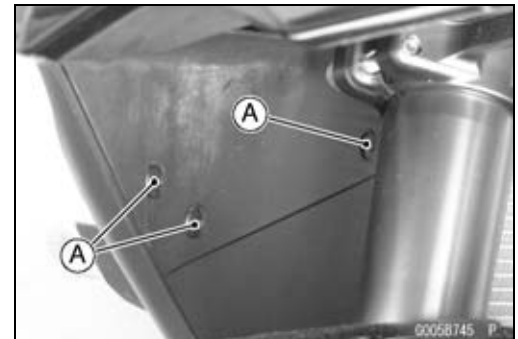

- Remove:

- Bolts [A]
 - Right Side [B]
 - Left Side [C]

- Pull out the lower fairing [D] outward to clear the projections [E].

- Pull out the lower fairing upward to clear the projection [F] (right side only).

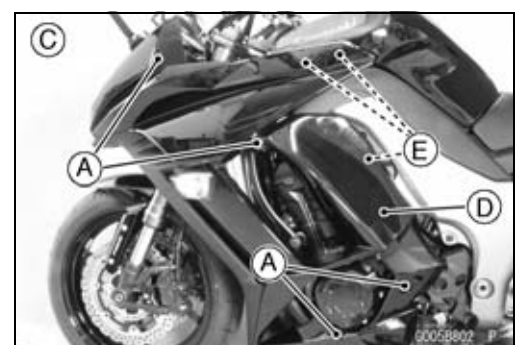
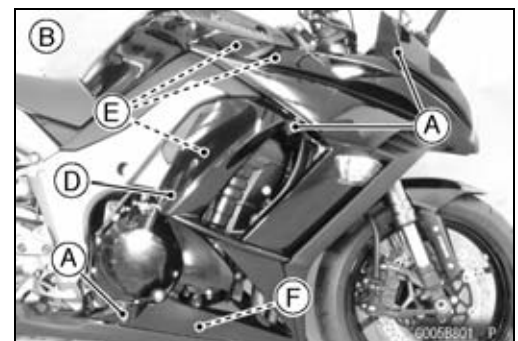

- Clear the projection [A] (Both Sides).

- Pull the lower fairing [B] rearward to clear the hook portions [C], and remove the lower fairing by moving it downward (Both Sides).

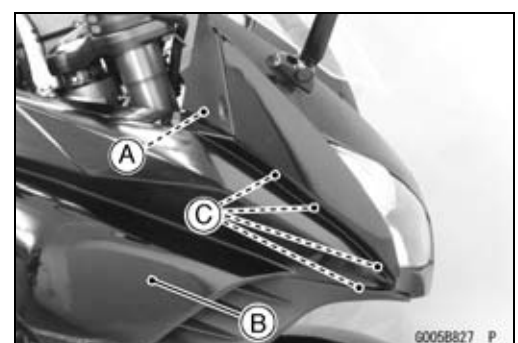

15-10 FRAME

Fairings

- Disconnect the turn signal light lead connector [A] (Both Sides).

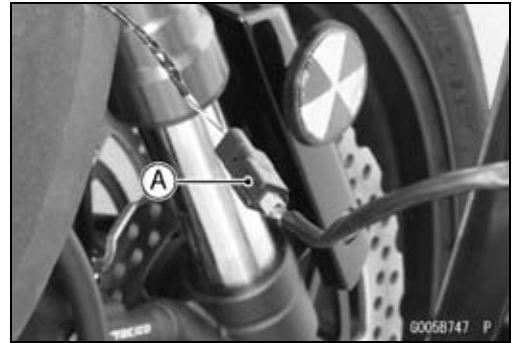

Lower Fairing Installation

- Be sure to install the dampers [A] and pad [B] (right side only).
Right Lower Fairing [C]
Left Lower Fairing [D]

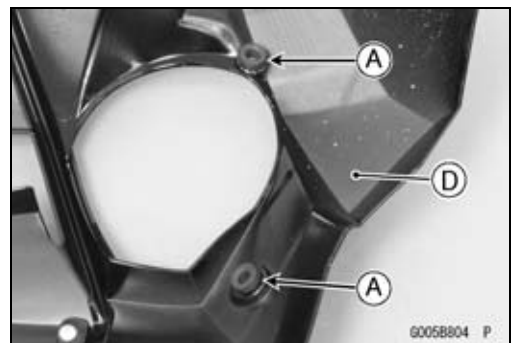
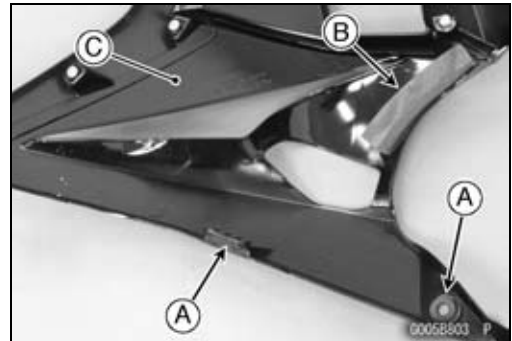

- Connect the turn signal light lead connector [A] (Both Sides).

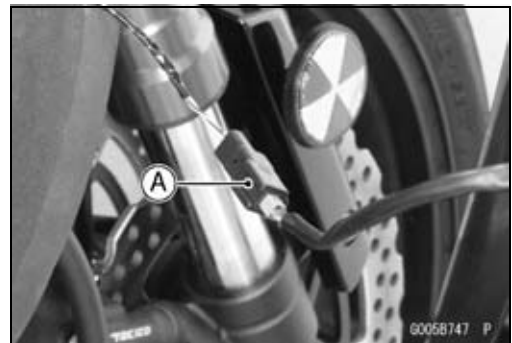

- Insert the hook portions [A] into the slits [B] on the upper fairing (Both Sides).

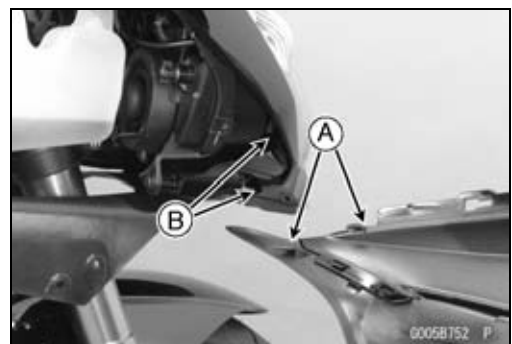

Fairings

- Insert the hook portions [A] into the slits [B] on the lower fairing (Both Sides).

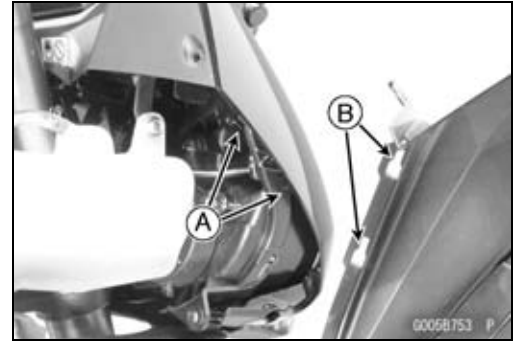

- Insert the stoppers [A] into the dampers [B] on the lower fairing (Both Sides).



- For left lower fairing installation, insert the stopper [A] into the damper [B] on the left lower side fairing.

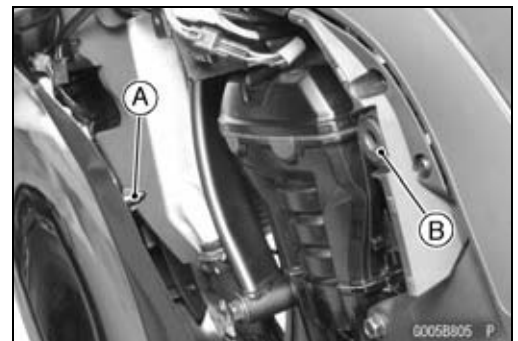

- For right lower fairing installation, insert the damper [A] into the projection [B] on the rear lower fairing.

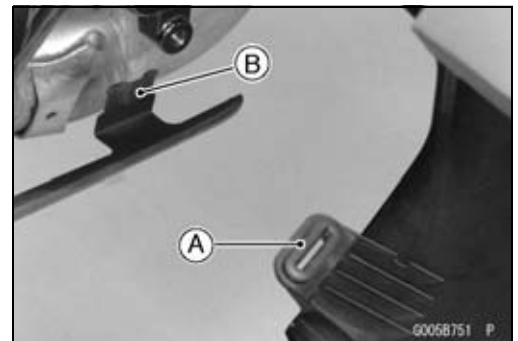

Lower Fairing Disassembly

- Remove:
 - Lower Fairing (see Lower Fairing Removal)
 - Screws [A]
 - Lower Fairing Lower [B]

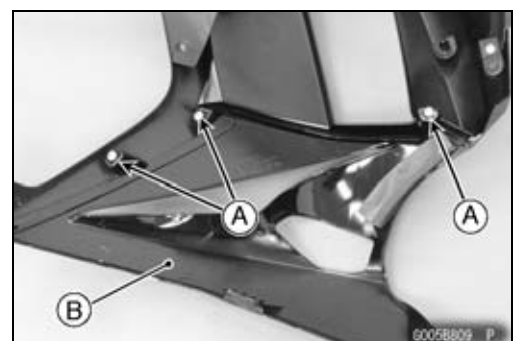

15-12 FRAME

Fairings

- Remove:
 - Quick Rivet [A]
 - Screws [B]
 - Inner Fairing [C]

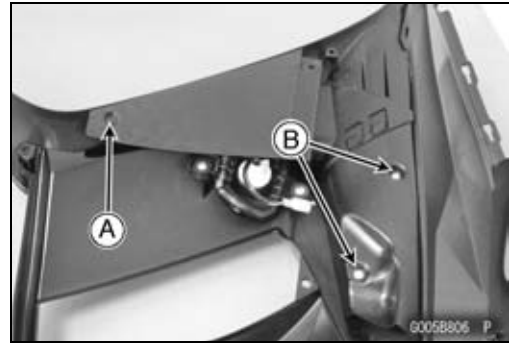

- Remove:
 - Screws [A]
 - Slat Fairing [B]
 - Lower Fairing Upper [C]

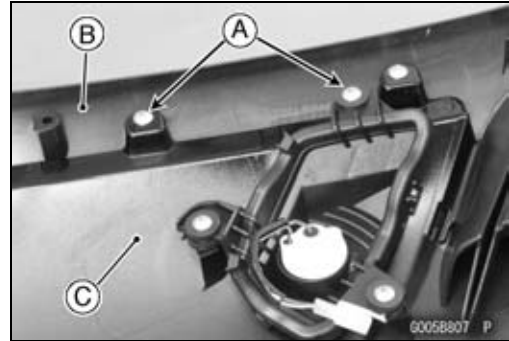

Lower Fairing Assembly

- Installation is the reverse of disassembly, note the following.

○ Insert the projection [A] into the hole [B].

○ Tighten:

Torque - Lower Fairing Lower Assembly Screws: 1.2 N-m (0.12 kgf-m, 11 in-lb)

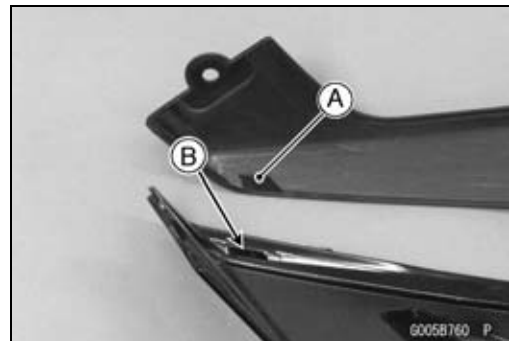

○ Insert the tabs [A] into the slots [B].

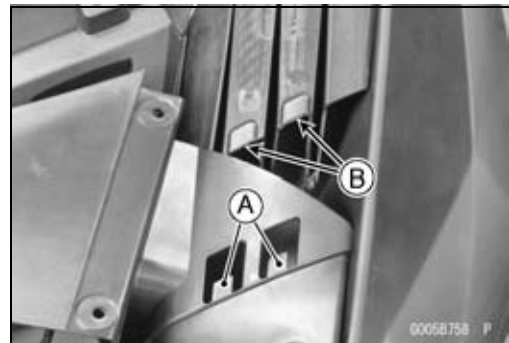

○ Tighten:

Torque - Lower Fairing Upper Assembly Screws [A]: 1.2 N-m (0.12 kgf-m, 11 in-lb)



Fairings

Rear Lower Fairing Removal

- Remove the bolt [A].
- Pull out the rear lower fairing [B] outward to clear the projections [C].

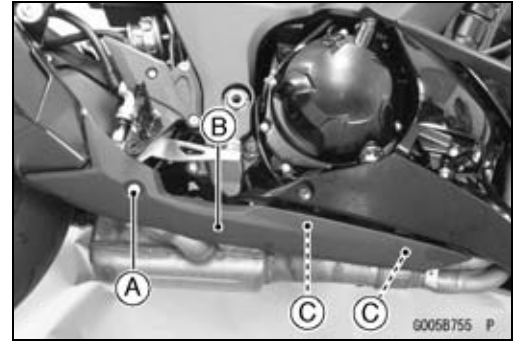

Rear Lower Fairing Installation

- Insert the projection [A] into the damper [B] on the right lower fairing.
- Insert the projection [C] into the damper [D].

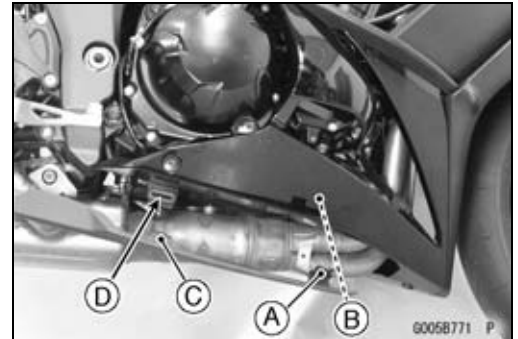

Windshield Removal

- Remove:
 - Bolts [A] with Washers
 - Windshield [B]

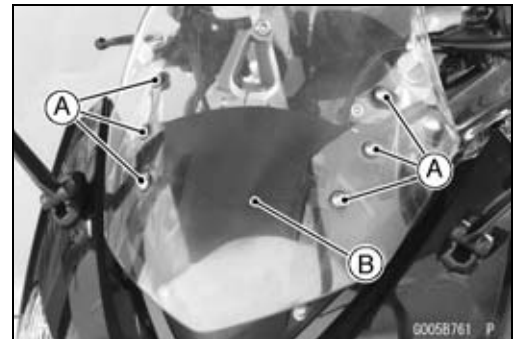

Windshield Installation

- Installation is the reverse of removal.

Upper Fairing Removal

- Remove:
 - Lower Fairing (see Lower Fairing Removal)
 - Windshield (see Windshield Removal)
 - Bolts [A] with Washers
 - Meter Cover [B]

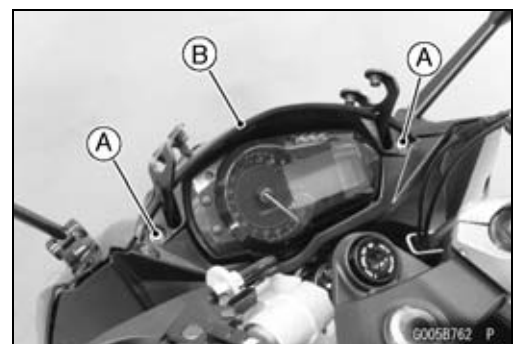

15-14 FRAME

Fairings

- Remove:
Bolts [A] with Washers
Windshield Bracket Cover [B]

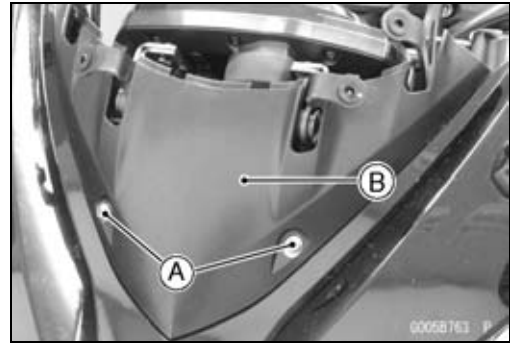

- Remove:
Nuts [A] (Both Sides)
Rear View Mirror [B] (Both Sides)

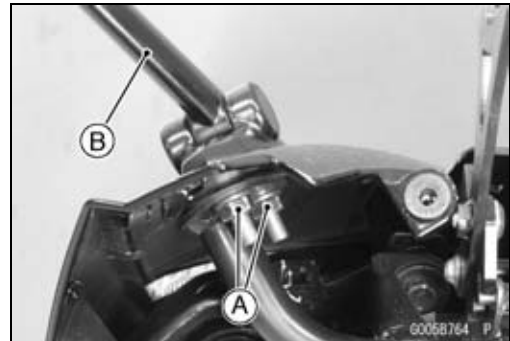

- Remove:
Bolt [A] (Both Sides)
Clamp [B] (Left Side only)

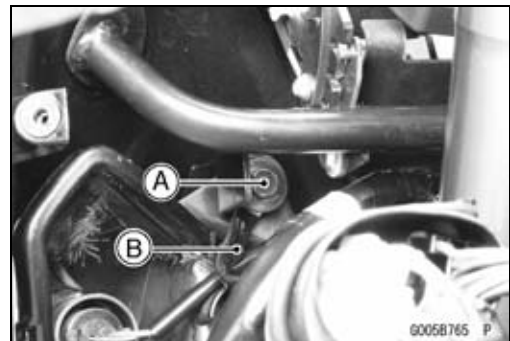

- Disconnect:
Headlight Lead Connectors [A]
City Light Lead Connectors [B]
- Remove the upper fairing with the headlight.

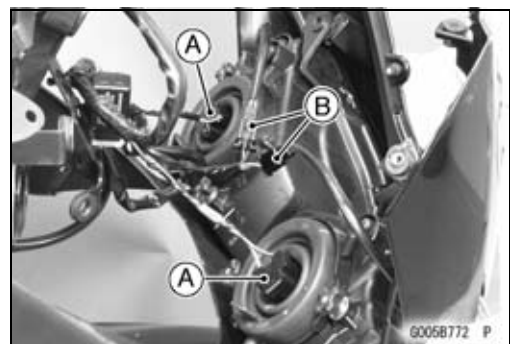

Upper Fairing Installation

- Installation is the reverse of removal.

Fairings

Upper Fairing Disassembly

- Remove:
 - Upper Fairing (see Upper Fairing Removal)
 - Screws [A]
 - Clamp [B]
 - Headlights [C]

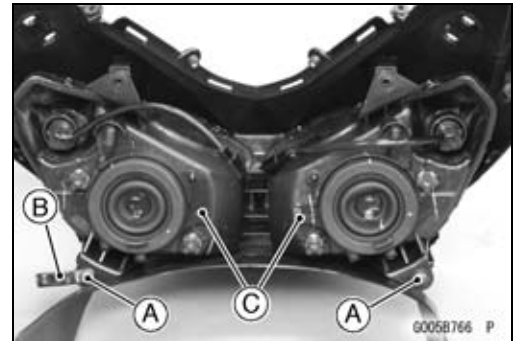

- Remove:
 - Screw [A]
- Separate the upper fairing.

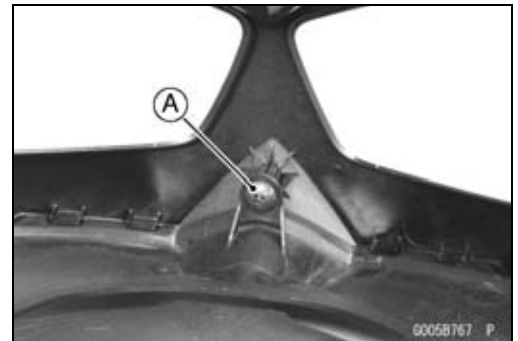

Upper Fairing Assembly

- Fit the projections [A] into the slots [B].

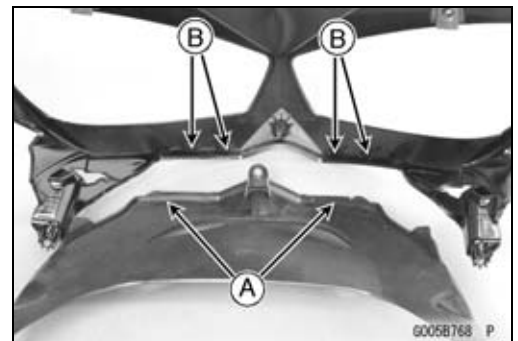

Windshield Bracket Disassembly

- Remove:
 - Upper Fairing (see Upper Fairing Removal)
 - Meter Unit (see Meter Unit Removal in the Electrical System chapter)
- Remove the springs [A].

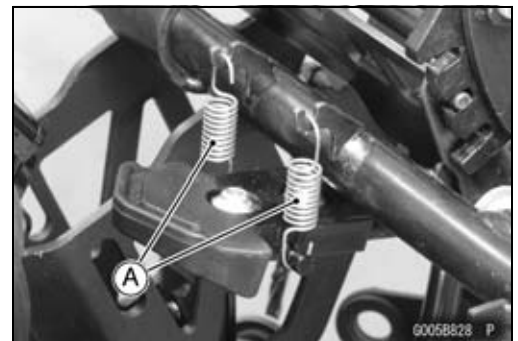

- Remove:
 - Stay Assembly Mounting Bolt [A] and Collars (Both Sides)
 - Bolt [B], Damper, Collar and Washers (Both Sides)
 - Stay Assembly [C]
 - Adjust Knob Assembly [D]

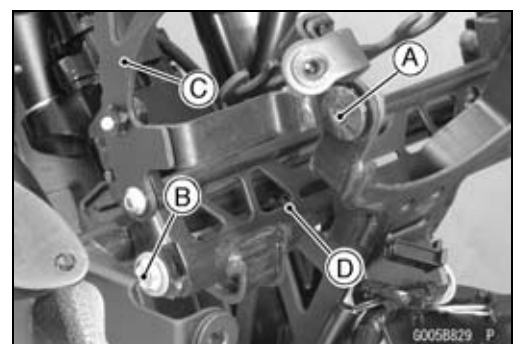

15-16 FRAME

Fairings

- Remove:
 - Bolts [A]
 - Adjust Knob [B]
 - Adjust Knob Bracket [C]

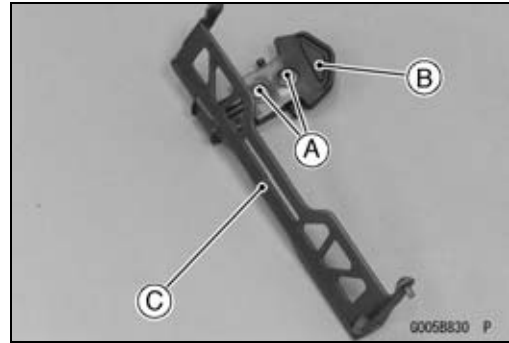

- Remove:
 - Bolts [A]
 - Stay Shaft [B]
 - Lower Stays [C]
 - Upper Stays [D]
 - Stoppers [E]

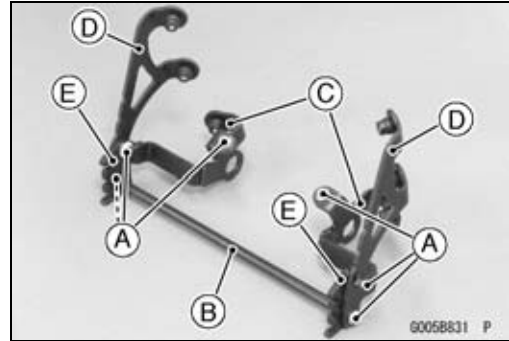

Windshield Bracket Assembly

- Confirm that the upper fairing bracket has been firmly installed by the mounting bolts [A].

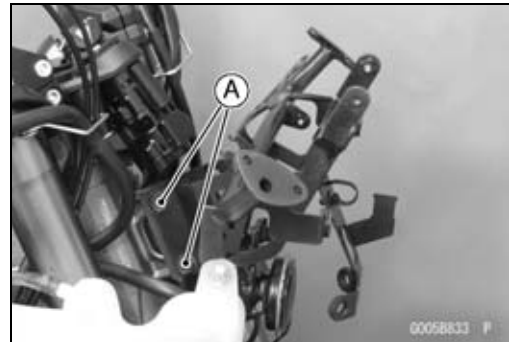

- Assemble the adjust knob assembly as shown in the figure.
 - Adjust Knob Bracket [A]
 - Adjust Knob [B]
 - Bolts [C]

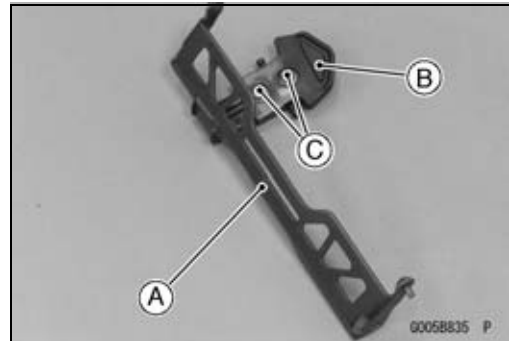

- Apply a non-permanent locking agent to the threads of the stay shaft mounting bolts [A].
- Assemble the stay assembly as shown in the figure.
 - Upper Stay [B]
 - Stopper [C]
 - Stay Shaft [D]
 - Stay Shaft Mounting Bolts
 - Stopper Mounting Bolts [E]
- Do not tighten firmly the stopper mounting bolts at this time.

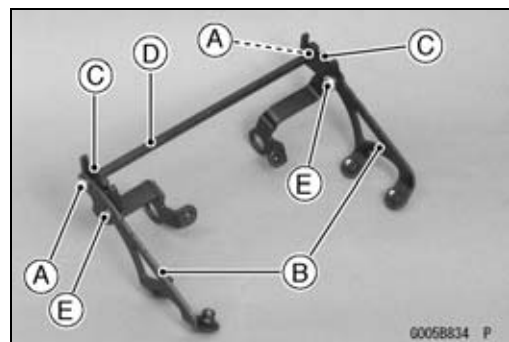

Fairings

- Apply grease to the dampers [A] and washers [B].
- Apply a non-permanent locking agent to the threads of the adjust knob assembly bolts [C].
- Install:
 - Adjust Knob Assembly [D]
 - Washers
 - Dampers
 - Collars [E]

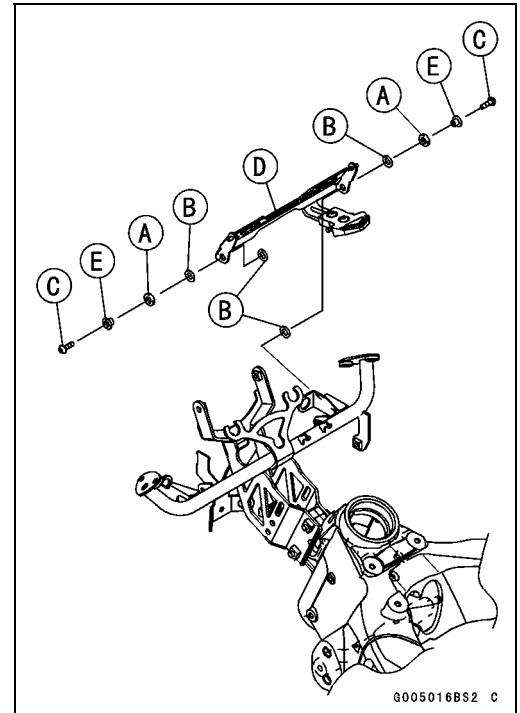

- Install the stay assembly [A].
- Fit the pins [B] of the adjust knob assembly into the grooves [C] of the stopper (Both Sides).

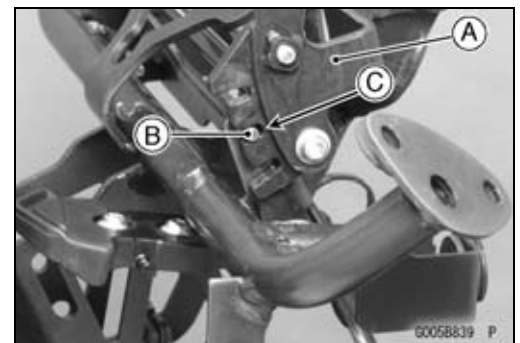

- Install:
 - Stay Assembly Mounting Bolts [A] and Collars
- Tighten the following bolts while the pins fit in the stoppers.

Torque - Stay Assembly Mounting Bolts: 6.9 N-m (0.70 kgf-m, 61 in-lb)

Stopper Mounting Bolts [B]: 4.2 N-m (0.42 kgf-m, 37 in-lb)

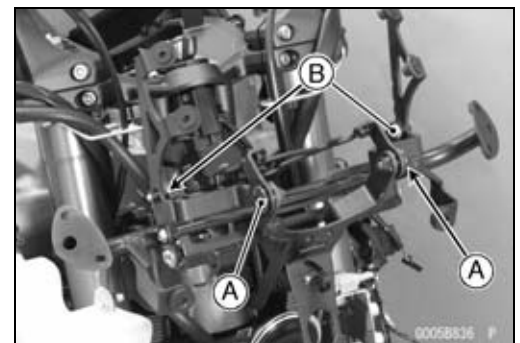

- Install:
 - Lower Stay [A]
 - Bolts [B]

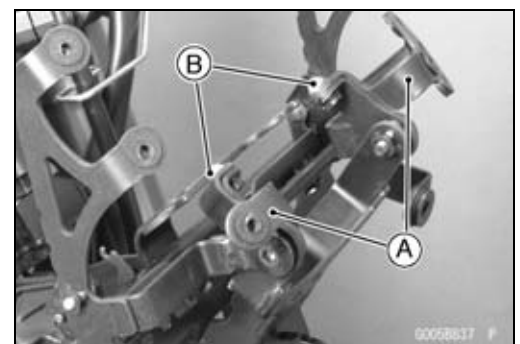

15-18 FRAME

Fairings

- Install:
 - Springs [A]
- Confirm that the position of the windshield stoppers [B] change smoothly and surely.
- Push the adjust knob [C] and change the positions of the windshield stoppers.
- ★ If the windshield stoppers do not move smoothly re-assemble the windshield bracket.

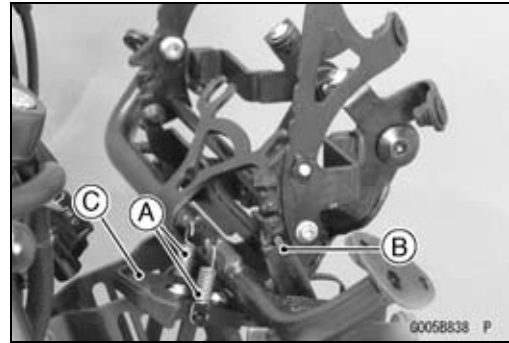

Windshield Bracket Assembly Removal

- Remove:
 - Upper Fairing (see Upper Fairing Assembly Removal)
 - Meter Unit (see Meter Unit Removal in the Electrical System chapter)
 - Horn Lead Connectors [A]
 - Turn Signal Relay [B]
 - Clamp [C] (Main Harness)
 - Bolt [D]

- Remove:
 - Bolts [A]
 - Windshield Bracket Assembly [B]

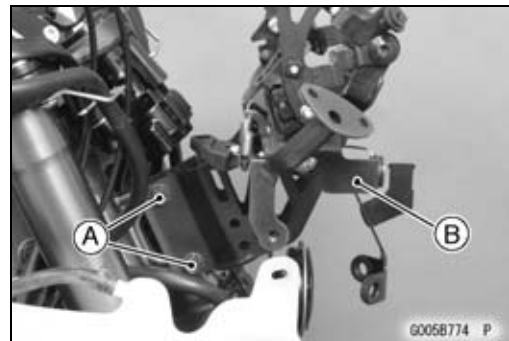
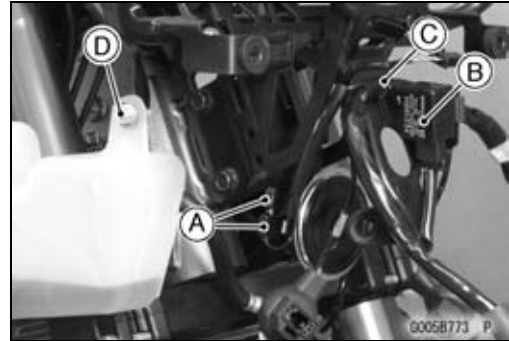

Windshield Bracket Assembly Installation

- Installation is the reverse of removal, note the following.
- Run the cables and leads correctly (see Cable, Wire, and Hose Routing section in the Appendix chapter).

Side Covers

Side Cover Removal

- Remove:
 - Lower Fairing (see Lower Fairing Removal)
 - Bolts [A] with Washers
- Pull the side cover [B] outward to clear the stoppers [C].

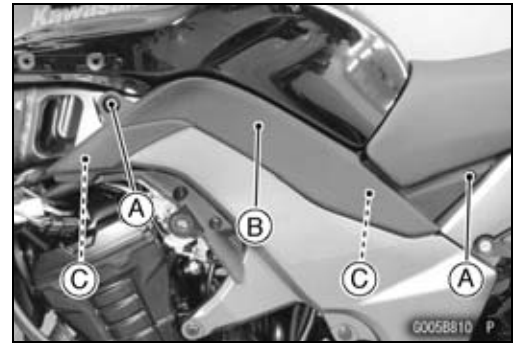

Side Cover Installation

- Be sure to install the pads [A].

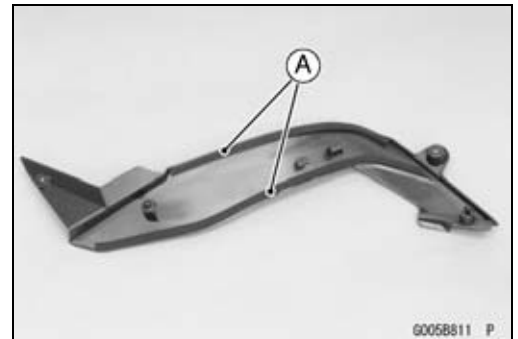

- Hang the hooks [A] to the frame.
- Insert the projections [B] into the holes [C].
- Install the bolts.



Left Lower Side Fairing Removal

- Remove:
 - Left Lower Fairing (see Lower Fairing Removal)
 - Bolts [A] with Washers
 - Lower Side Fairing [B]

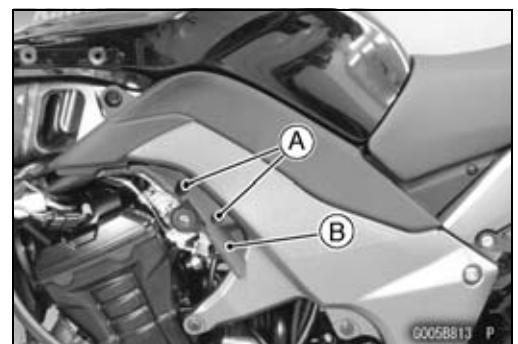

Left Lower Side Fairing Installation

- Installation is the reverse of removal, note the following.
 - Be sure to install the damper [A].

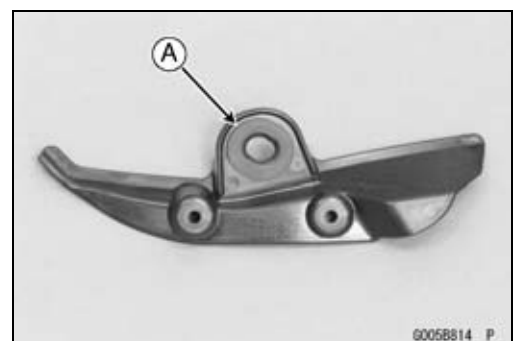

15-20 FRAME

Seat Covers

Seat Cover Removal

- Remove:
 - Seats (see Rear/Front Seat Removal)
 - Bolts [A] with Collars and Washers (Both Sides)
 - Grab Rail [B] (Both Sides)

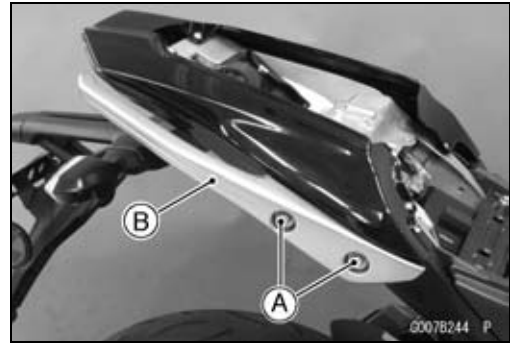

- Remove:
 - Bolts [A]
 - Seat Cover [B]

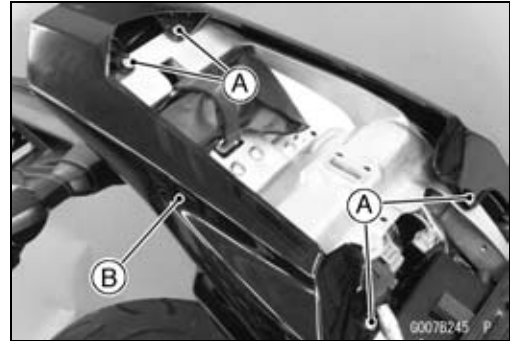

Seat Cover Installation

- Installation is the reverse of removal, note the following.
 - Fit the craws [A] into the slits [B] on the rear fender.

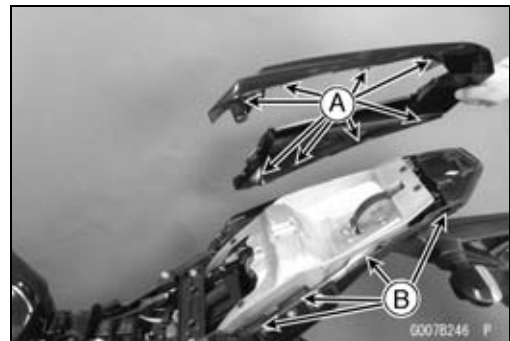

- Install:
 - Bolts [A] with Collars and Washers (Both Sides)
 - Grab Rail [B] (Both Sides)
- Tighten:
 - Torque - Grab Rail Mounting Bolts: 25 N-m (2.5 kgf-m, 18 ft-lb)**

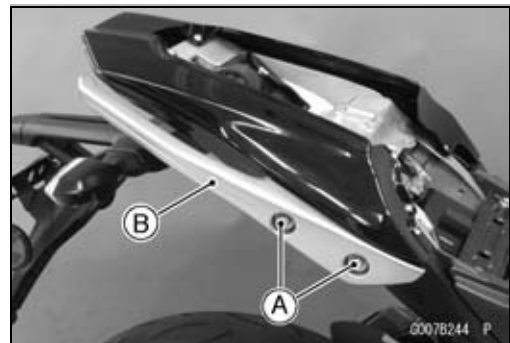

Fenders

Front Fender Removal

- Remove:
 - Brake Hose Clamps [A] (Both Sides)
 - Bolts [B] with Washers (Both Sides)
 - Reflectors [C] (Both Sides, US, CA and CAL Models)
 - Front Fender [D]

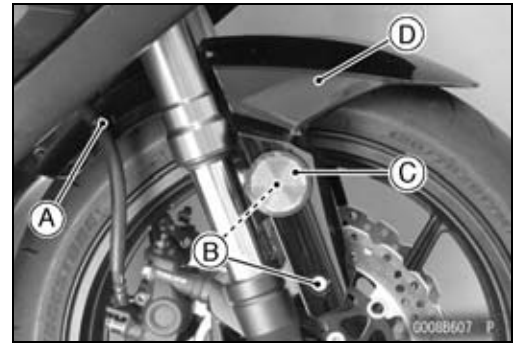

Front Fender Installation

- Installation is the reverse of removal, note the following.
- Install the front fender to the front fork.
- Tighten:
 - Torque - Front Fender Mounting Bolts: 3.9 N·m (0.40 kgf·m, 35 in·lb)**
- Replace the brake hose clamps with new ones (ZX1000GB/HB Early Models).
- Install the brake hose clamps to the front fender holes.
- For ZX1000GB/HB Late Models ~, face the lock portion [A] of the brake hose clamp backward.

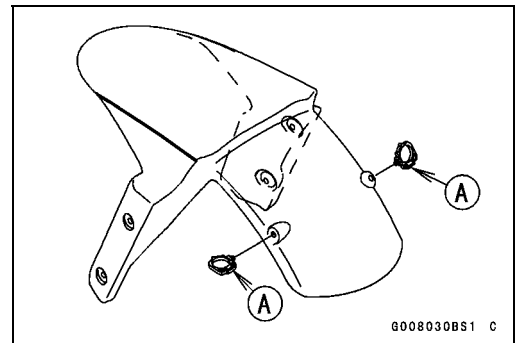

Flap and Rear Fender Removal

- Remove:
 - Seats (see Front/Rear Seat Removal)
 - Seat Cover (see Seat Cover Removal)
 - Owner's Tool [A]



- Remove:
 - Bolts [A]

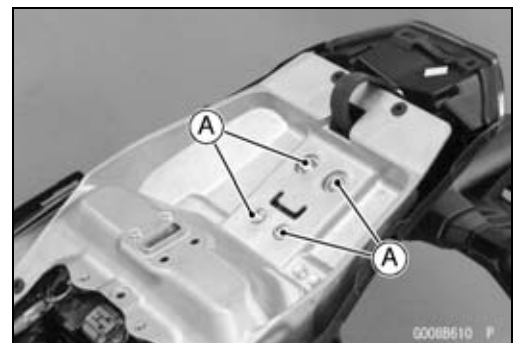

15-22 FRAME

Fenders

- Remove:
Bolts [A]

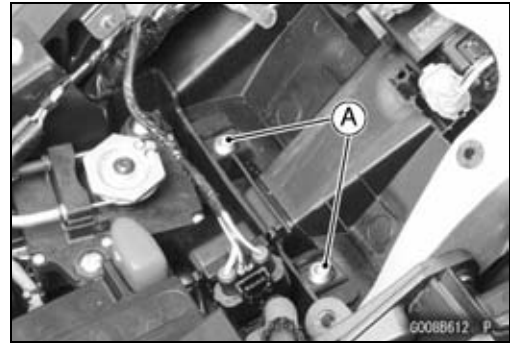

- Push the rear fender [A] downward.
- Remove:
Relay Box [B]
ECU [C]
- Disconnect:
Turn Signal Light Lead Connectors [D]
Licence Plate Light Lead Connector [E]
Tali Light Lead Connector [F]
- Remove the rear fender rearward.

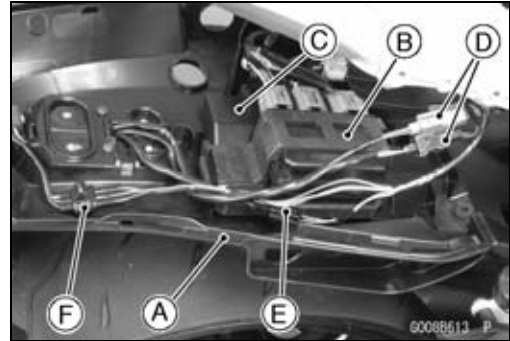

Flap and Rear Fender Installation

- Installation is the reverse of removal, note the following.
- Replace the rear fender mounting bolts [A] with new ones.
- Run the cables, leads, harness and hose correctly (see Cable, Wire, and Hose Routing section in the Appendix chapter).
- Tighten:
Torque - Grab Rail Mounting Bolts: 25 N-m (2.5 kgf-m, 18 ft-lb)

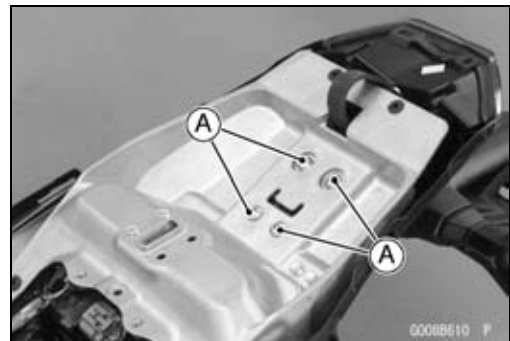

Frame

Frame Inspection

- Visually inspect the frame for cracks, dents, bending, or warp.
- If there is any damage to the frame, replace it.

⚠ WARNING

A repaired frame may fail in use, possibly causing an accident resulting in injury or death. If the frame is bent, dented, cracked, or warped, replace it.

Rear Frame Removal

- Remove:
 - Rear Fender (see Rear Fender Removal)
 - Rear Frame Bolts [A] (Both Sides)
 - Rear Frame [B]

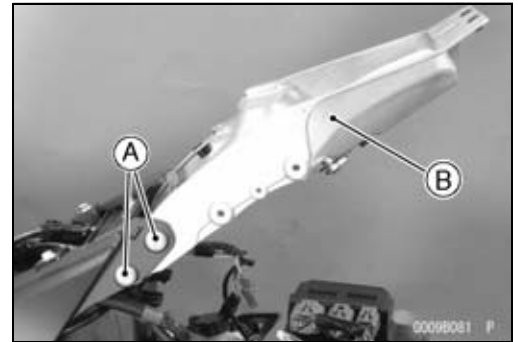

Rear Frame Installation

- Apply a non-permanent locking agent to the thread of the rear frame bolts.
- Tighten:
 - Torque - Rear Frame Bolts: 25 N·m (2.5 kgf·m, 18 ft·lb)

Rear Frame Bracket Removal

- Remove:
 - Side Cover (see Side Cover Removal)
 - Battery Case (see Battery Case Removal)
 - Rear Frame (see Rear Frame Removal)
 - Bolts [A]
 - Clamp [B] (Left Side Only)

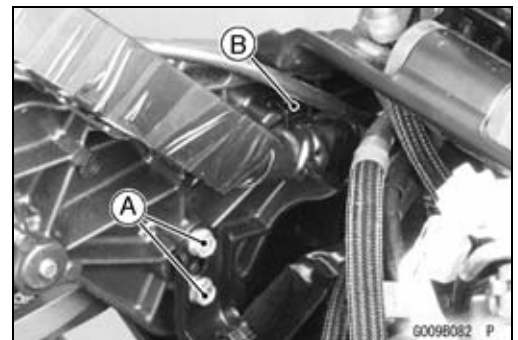

- Remove:
 - Rear Footpeg Bracket Bolts [A] (Both Sides)
 - Rear Frame Bracket Bolts [B] (Both Sides)
 - Rear Frame Bracket [C]

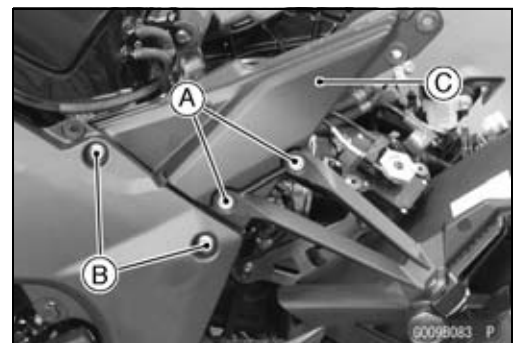

Rear Frame Bracket Installation

- Tighten:
 - Torque - Rear Frame Bracket Bolts: 44 N·m (4.5 kgf·m, 32 ft·lb)
 - Rear Footpeg Bracket Bolts: 25 N·m (2.5 kgf·m, 18 ft·lb)

15-24 FRAME

Battery Case

Battery Case Removal

- Remove:
 - Battery (see Battery Removal in the Electrical System chapter)
 - Exhaust Butterfly Valve Actuator [A] (see Exhaust Butterfly Valve Actuator Removal in the Fuel System (DFI) chapter)
 - Seat Bracket
- Disconnect:
 - Vehicle-down Sensor Connector [B]
 - Starter Relay Connector [C]
- Remove:
 - Fuse Box 2 [D]
 - Fuse Box 1 [E]
 - Bolts [F]
 - Clamp [G]
- Pull the battery case rearward.
- Remove the clamp [A] (regulator/rectifier lead) from the battery case.
- Remove the battery case.

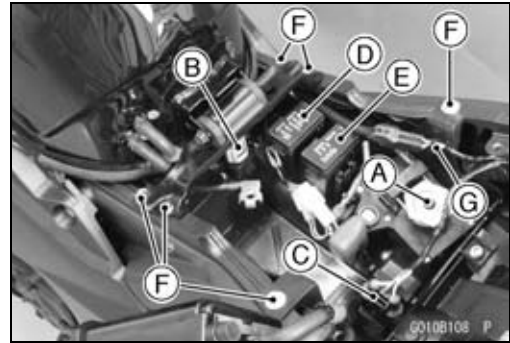

Battery Case Installation

- Installation is the reverse of removal.
- Install the removed parts (see appropriate chapters).
- Replace the regulator/rectifier lead clamp with a new one.
- Run the cables, leads, harness and hose correctly (see Cable, Wire, and Hose Routing section in the Appendix chapter).

Guard

Mud Guard Removal

- Remove:
 - Rear Lower Fairing (see Rear Lower Fairing Removal)
 - Right Front Footpeg Bracket Bolts [A]

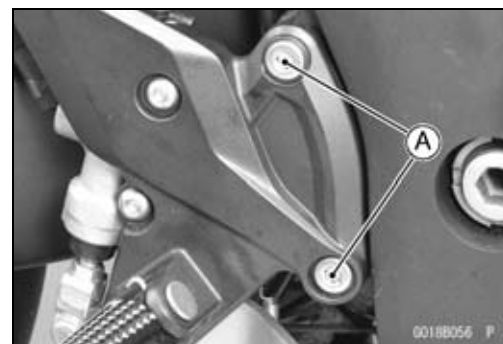

- Remove:
 - Bolts [A]



- Remove:
 - Quick Rivets [A]
 - Mud Guard [B]

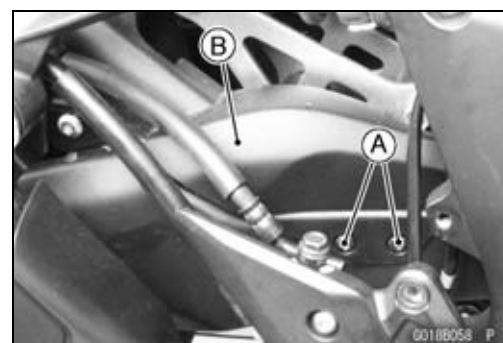

Mud Guard Installation

- Installation is the reverse of removal, note the following.
 - Torque - Front Footpeg Bracket Bolts: 25 N·m (2.5 kgf·m, 18 ft·lb)**

15-26 FRAME

Sidestand

Sidestand Removal

- Raise the rear wheel off the ground with the stand.
- Remove:
 - Sidestand Switch Bolt [A] and Nut [B]
 - Sidestand Switch [C]

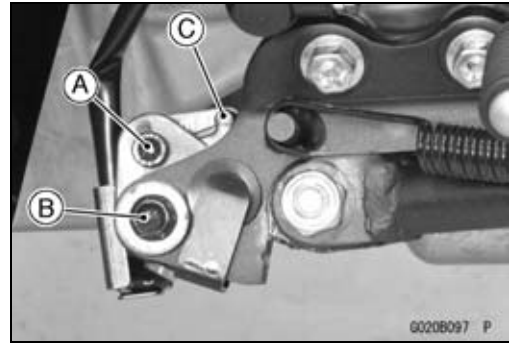

- Remove:
 - Spring [A]
 - Sidestand Nut [B]
 - Sidestand Bolt [C]
 - Sidestand [D]

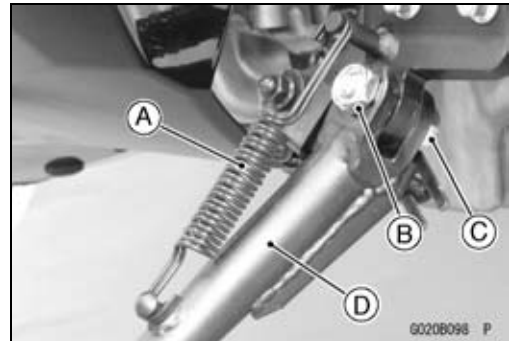

Sidestand Installation

- Apply grease to the sliding area [A] of the sidestand [B].
- Replace the sidestand nut [C] with a new one.
- Tighten the bolt with the nut.

Torque - Sidestand Bolt [D]: 44 N·m (4.5 kgf·m, 32 ft·lb)

- Hook the spring [E] so that the long spring end faces upward.
- Install the spring hook direction as shown in the figure.

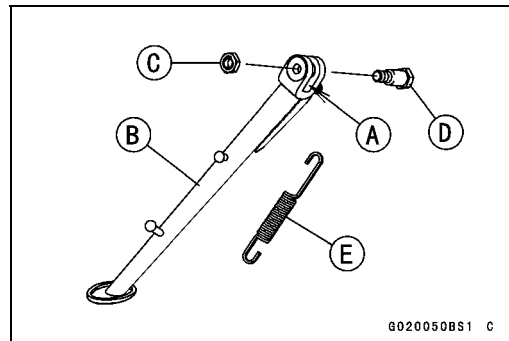

- Install the sidestand switch.
- Fit the slit [A] on the sidestand switch to the pin [B] on the sidestand.
- Apply a non-permanent locking agent to the thread of the switch bolt, and tighten it.

Torque - Sidestand Switch Bolt: 8.8 N·m (0.90 kgf·m, 78 in·lb)

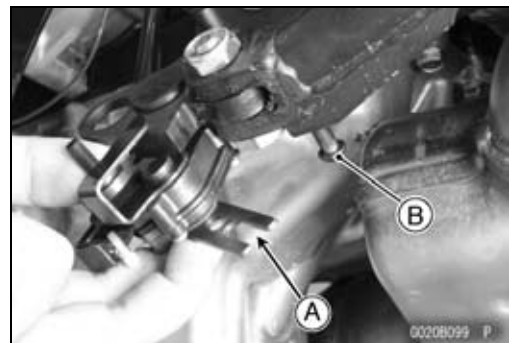

Electrical System

Table of Contents

Exploded View.....	16-3
Specifications	16-10
Special Tools and Sealant	16-11
Parts Location.....	16-13
Wiring Diagram (US, CA and CAL Models).....	16-16
Wiring Diagram (Other than US, CA and CAL Models).....	16-18
Wiring Diagram (CA with ABS Models)	16-20
Wiring Diagram (Other than CA with ABS Models)	16-22
Precautions.....	16-24
Electrical Wiring.....	16-25
Wiring Inspection	16-25
Battery	16-26
Battery Removal	16-26
Battery Installation	16-26
Battery Activation	16-26
Precautions	16-29
Interchange	16-30
Charging Condition Inspection.....	16-30
Refreshing Charge.....	16-30
Charging System.....	16-32
Alternator Cover Removal.....	16-32
Alternator Cover Installation.....	16-32
Stator Coil Removal	16-33
Stator Coil Installation	16-33
Alternator Rotor Removal	16-33
Alternator Rotor Installation	16-34
Alternator Inspection	16-36
Regulator/Rectifier Inspection.....	16-37
Charging Voltage Inspection	16-39
Ignition System.....	16-41
Crankshaft Sensor Removal	16-41
Crankshaft Sensor Installation	16-42
Crankshaft Sensor Inspection.....	16-43
Crankshaft Sensor Peak Voltage Inspection.....	16-43
Timing Rotor Removal	16-44
Timing Rotor Installation	16-44
Stick Coil Removal.....	16-44
Stick Coil Installation.....	16-44
Stick Coil Inspection.....	16-45
Stick Coil Primary Peak Voltage	16-45
Spark Plug Removal	16-46
Spark Plug Installation	16-46
Spark Plug Condition Inspection.....	16-46
Interlock Operation Inspection	16-46
IC Igniter Inspection.....	16-47
Electric Starter System.....	16-50
Starter Motor Removal.....	16-50
Starter Motor Installation.....	16-51
Starter Motor Disassembly.....	16-51
Starter Motor Assembly	16-52

16-2 ELECTRICAL SYSTEM

Brush Inspection	16-54
Commutator Cleaning and Inspection.....	16-54
Armature Inspection.....	16-55
Brush Lead Inspection	16-55
Right-hand End Cover Inspection	16-55
Starter Relay Inspection.....	16-55
Lighting System.....	16-58
Headlight Beam Horizontal Adjustment	16-58
Headlight Beam Vertical Adjustment.....	16-58
Headlight Bulb Replacement	16-58
Headlight Removal/Installation	16-59
City Light Bulb Replacement.....	16-60
Tail/Brake Light (LED) Removal.....	16-60
Tail/Brake Light (LED) Installation.....	16-60
License Plate Light Bulb Replacement	16-61
Turn Signal Light Bulb Replacement	16-63
Turn Signal Relay Inspection	16-64
Air Switching Valve	16-67
Air Switching Valve Operation Test.....	16-67
Air Switching Valve Unit Test	16-67
Radiator Fan System.....	16-69
Fan Motor Inspection	16-69
Meter, Gauge, Indicator Unit.....	16-71
Meter Unit Removal/Installation	16-71
Meter Unit Disassembly.....	16-71
Electronic Combination Meter Unit Inspection.....	16-72
Fuel Level Sensor Line Self-Diagnosis Mode Inspection.....	16-81
Immobilizer System (Equipped Models)	16-83
Operational Cautions	16-83
Key Registration.....	16-83
Immobilizer System Parts Replacement	16-101
Immobilizer System Inspection	16-102
Immobilizer System (Equipped Models)	16-103
Switches and Sensors.....	16-104
Brake Light Timing Inspection.....	16-104
Brake Light Timing Adjustment	16-104
Switch Inspection.....	16-104
Water Temperature Sensor Inspection	16-105
Speed Sensor Removal.....	16-105
Speed Sensor Installation	16-106
Speed Sensor Inspection.....	16-106
Oxygen Sensor Removal (Equipped Models).....	16-106
Oxygen Sensor Installation (Equipped Models).....	16-107
Oxygen Sensor Inspection (Equipped Models).....	16-107
Fuel Level Sensor Inspection.....	16-107
Relay Box	16-108
Relay Box Removal	16-108
Relay Circuit Inspection	16-108
Diode Circuit Inspection.....	16-109
Fuse.....	16-111
30 A Main Fuse Removal.....	16-111
Fuse Box Fuse Removal.....	16-111
15 A FI Fuse Removal	16-111
Fuse Installation.....	16-111
Fuse Inspection.....	16-112

Exploded View

This page intentionally left blank.

16-4 ELECTRICAL SYSTEM

Exploded View

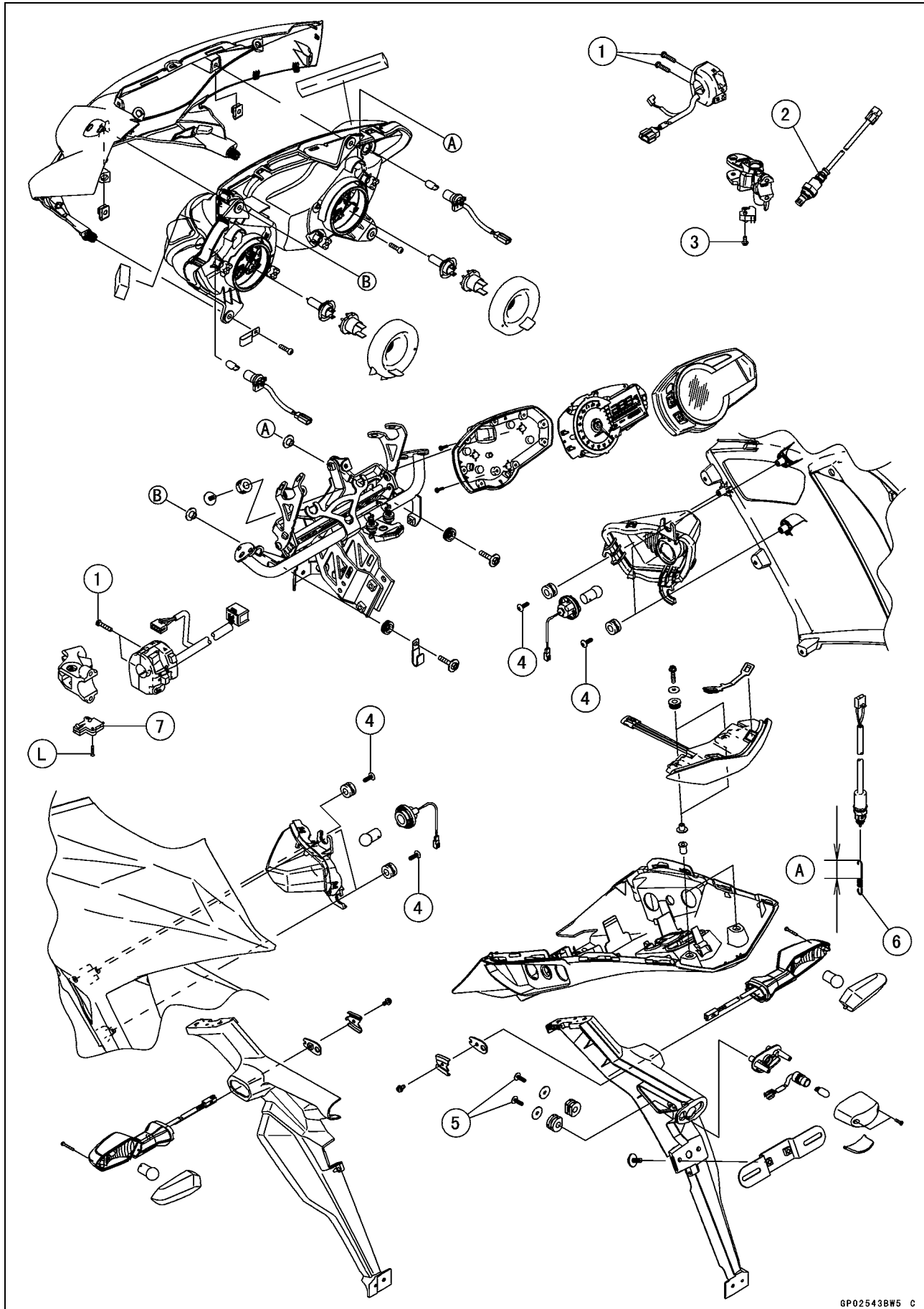

Exploded View

No.	Fastener	Torque			Remarks
		N·m	kgf·m	ft·lb	
1	Switch Housing Screws	3.5	0.36	31 in·lb	
2	Oxygen Sensor (Equipped Models)	44	4.5	32	
3	Front Brake Light Switch Screw	1.2	0.12	11 in·lb	
4	Front Turn Signal Light Mounting Screws	1.2	0.12	11 in·lb	
5	Licence Plate Light Mounting Screws	1.2	0.12	11 in·lb	

6. Install the rear brake light switch spring so that the longer side [A] faces upward.

7. Starter Lockout Switch

L: Apply a non-permanent locking agent.

16-6 ELECTRICAL SYSTEM

Exploded View

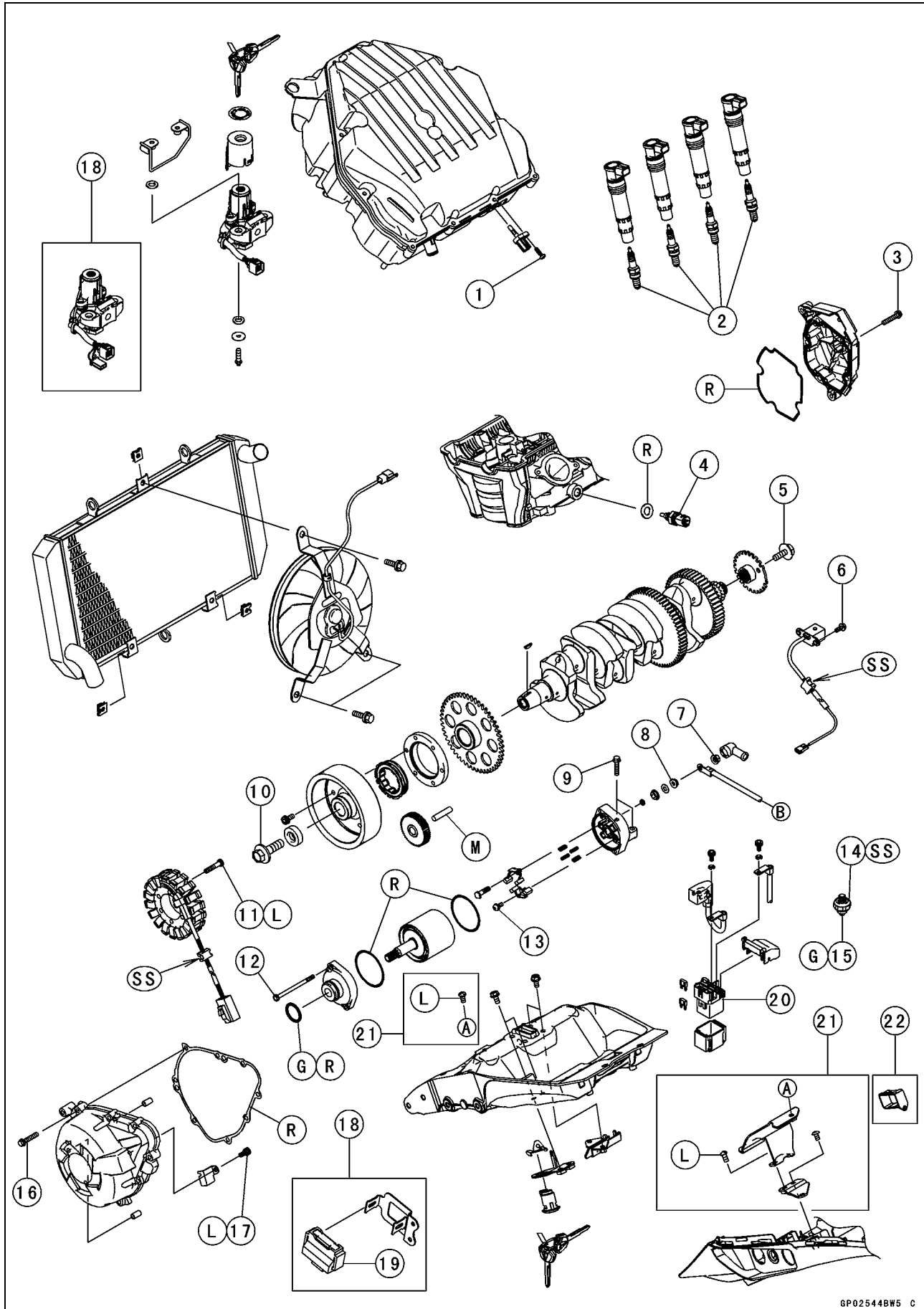

Exploded View

No.	Fastener	Torque			Remarks
		N·m	kgf·m	ft·lb	
1	Intake Air Temperature Sensor Mounting Screw	1.2	0.12	11 in·lb	
2	Spark Plugs	13	1.3	115 in·lb	
3	Crankshaft Sensor Cover Bolts	12	1.2	106 in·lb	
4	Water Temperature Sensor	30	3.0	22	
5	Timing Rotor Bolt	39	4.0	29	
6	Crankshaft Sensor Bolts	5.9	0.60	52 in·lb	
7	Starter Motor Cable Terminal Nut	5.9	0.60	52 in·lb	
8	Starter Motor Terminal Locknut	11	1.1	97 in·lb	
9	Starter Motor Mounting Bolts	9.8	1.0	87 in·lb	
10	Alternator Rotor Bolt	155	15.8	114	
11	Stator Coil Bolts	12	1.2	106 in·lb	L
12	Starter Motor Through Bolts	4.9	0.50	43 in·lb	
13	Brush Holder Screw	3.8	0.39	34 in·lb	
14	Oil Pressure Switch	15	1.5	11	SS
15	Oil Pressure Switch Terminal Bolt	2.0	0.20	18 in·lb	G
16	Alternator Cover Bolts	12	1.2	106 in·lb	
17	Alternator Lead Holding Plate Bolt	12	1.2	106 in·lb	L

18. Immobilizer Model

19. Immobilizer Amplifier

20. Starter Relay

21. WVTA (78.2H) and GB WVTA (FULL H) Models

22. ZX1000GB GB WVTA (FULL H) Early Model

G: Apply grease.

L: Apply a non-permanent locking agent.

M: Apply molybdenum disulfide grease.

R: Replacement Parts

SS: Apply silicone sealant.

16-8 ELECTRICAL SYSTEM

Exploded View

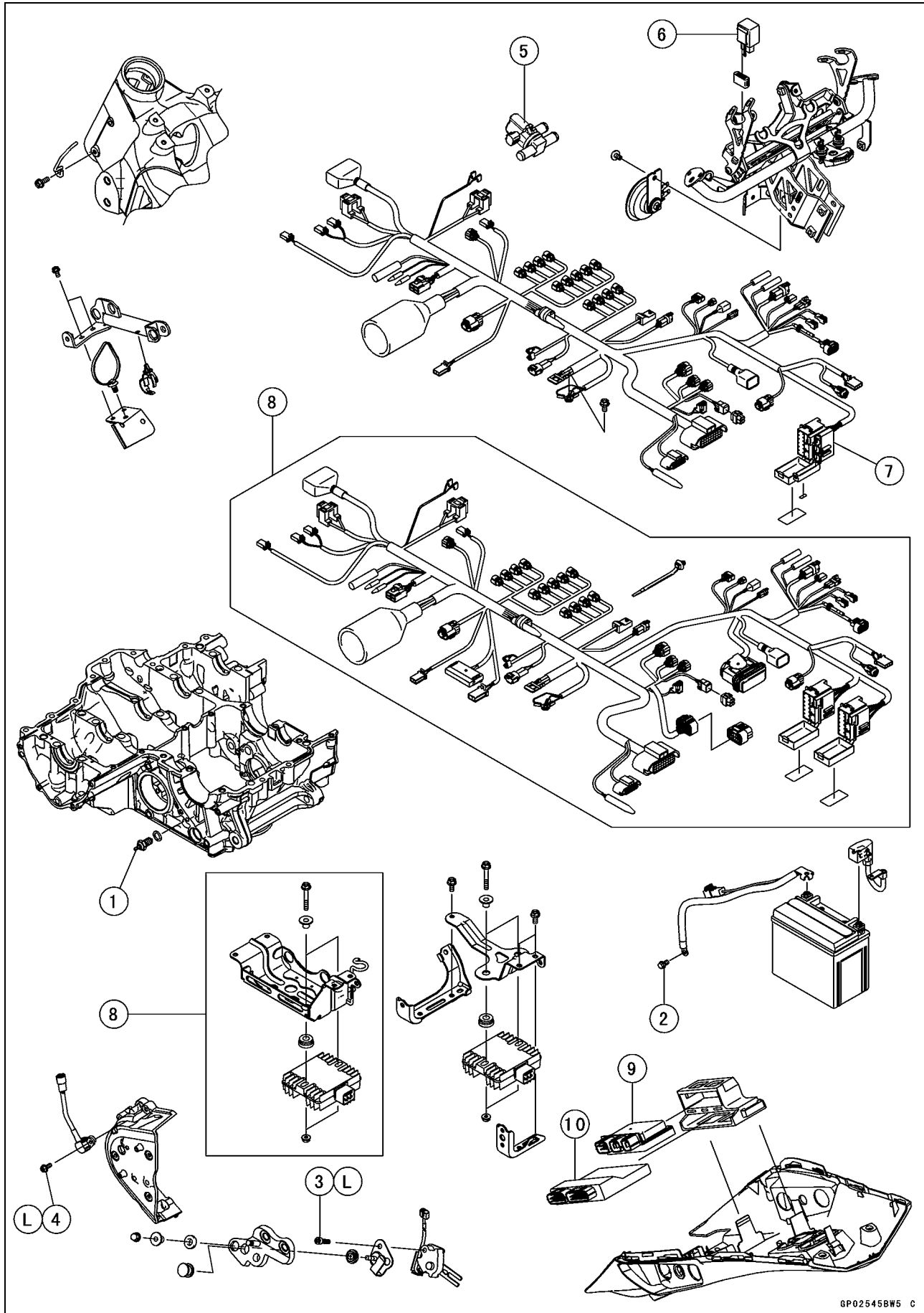

Exploded View

No.	Fastener	Torque			Remarks
		N·m	kgf·m	ft·lb	
1	Neutral Switch	15	1.5	11	
2	Engine Ground Cable Terminal Bolt	9.8	1.0	87 in·lb	
3	Sidestand Switch Bolt	8.8	0.90	78 in·lb	L
4	Speed Sensor Mounting Bolt	6.9	0.70	61 in·lb	L

- 5. Air Switching Valve
 - 6. Turn Signal Relay
 - 7. Fuel Box
 - 8. ABS Equipped Models
 - 9. Relay Box
 - 10. ECU
- L: Apply a non-permanent locking agent.

16-10 ELECTRICAL SYSTEM

Specifications

Item	Standard
Battery Type Model Name Capacity Voltage	Sealed Battery YTX9-BS 12 V 8 Ah 12.8 V or more
Charging System Type Alternator Output Voltage Stator Coil Resistance Charging Voltage (Regulator/Rectifier Output Voltage)	Three-phase AC 43 V or more at 4 000 rpm 0.18 ~ 0.28 Ω at 20°C (68°F) 14.2 ~ 15.2 V
Ignition System Crankshaft Sensor Resistance Crankshaft Sensor Peak Voltage Stick Coil: Primary Winding Resistance Secondary Winding Resistance Primary Peak Voltage Spark Plug: Type Gap	376 ~ 564 Ω 2.0 V or more 1.1 ~ 1.5 Ω 10.8 ~ 16.2 k Ω 100 V or more NGK CR9EIA-9 0.8 ~ 0.9 mm (0.031 ~ 0.035 in.)
Electric Starter System Starter Motor: Brush Length	12 mm (0.47 in.) [Service limit: 6.5 mm, 0.26 in.]
Air Switching Valve Resistance	18 ~ 22 Ω at 20°C (68°F)
Switches and Sensors Rear Brake Light Switch Timing Engine Oil Pressure Switch Connections Water Temperature Sensor Resistance Fuel Level Sensor Resistance: Full Position Empty Position	ON after about 10 mm (0.39 in.) pedal travel When engine is stopped: ON When engine is running: OFF in the text 9.6 ~ 12.4 Ω 222 ~ 228 Ω

Special Tools and Sealant

**Hand Tester:
57001-1394**

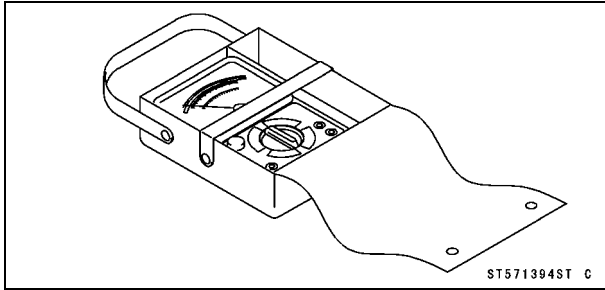

**Grip:
57001-1591**

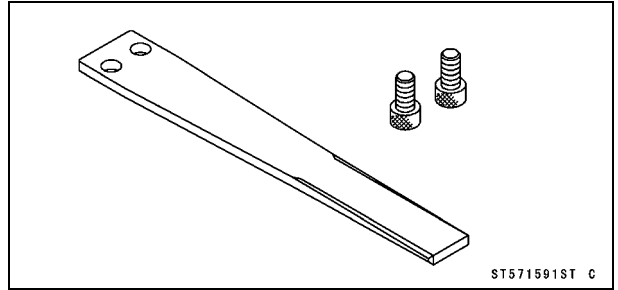

**Peak Voltage Adapter:
57001-1415**

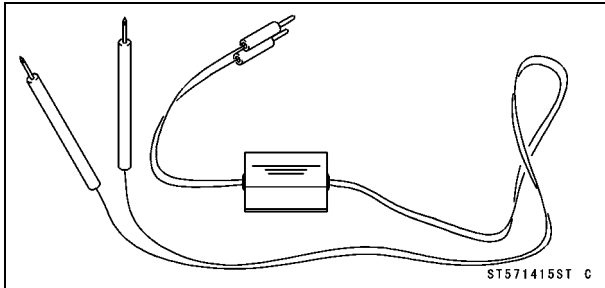

**Flywheel & Pulley Holder:
57001-1605**

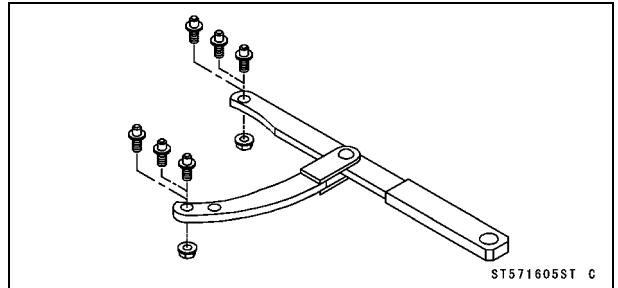

**Lead Wire - Peak Voltage Adapter:
57001-1449**

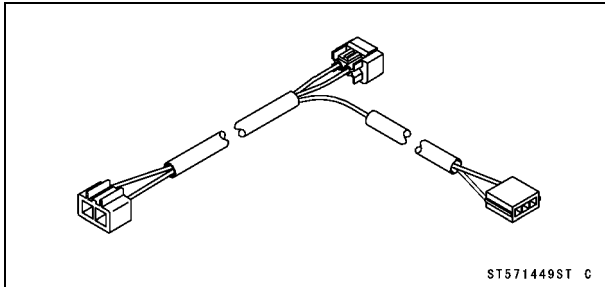

**Flywheel Puller Assembly, M38 x 1.5/M35 x 1.5:
57001-1615**

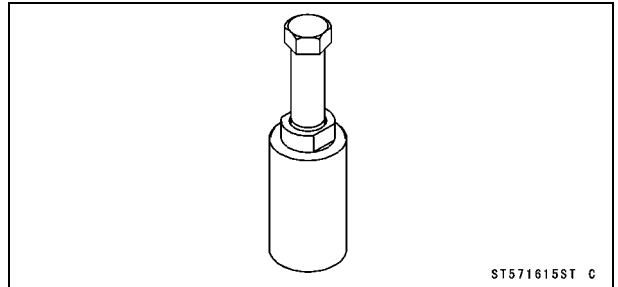

**Needle Adapter Set:
57001-1457**

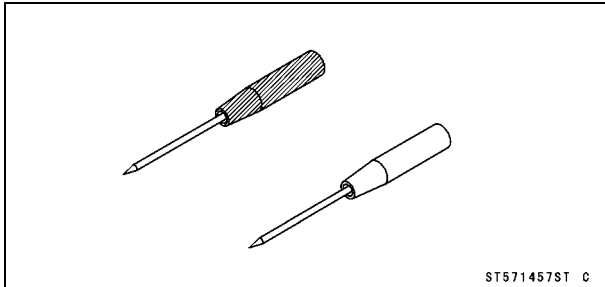

**Stopper:
57001-1679**

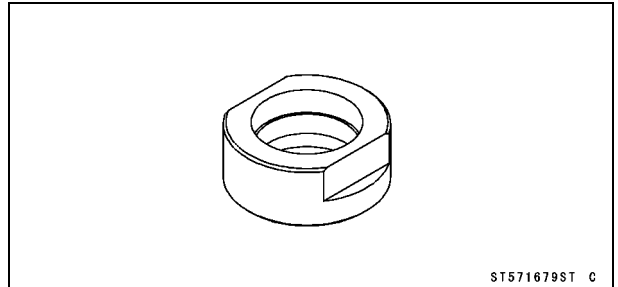

**Key Registration Unit:
57001-1582**

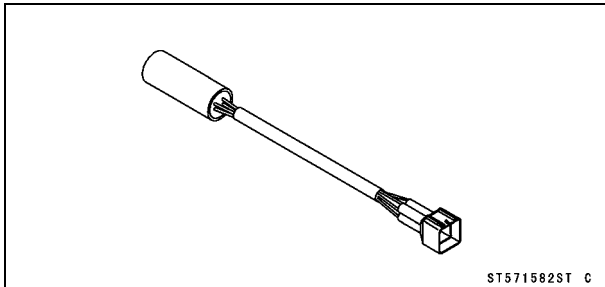

**Rotor Holder:
57001-1690**

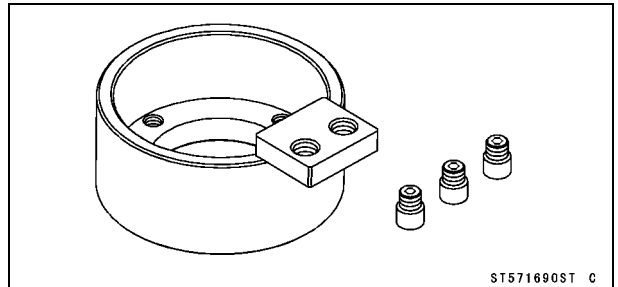

16-12 ELECTRICAL SYSTEM

Special Tools and Sealant

Key Registration Adapter:

57001-1746

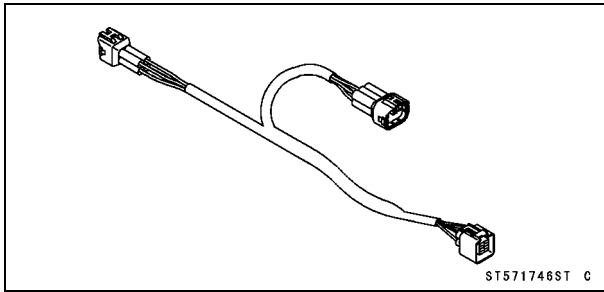

Liquid Gasket, TB1211F:

92104-0004

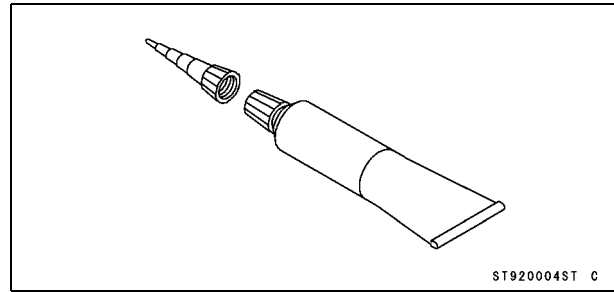

Rotor Holder:

57001-1757

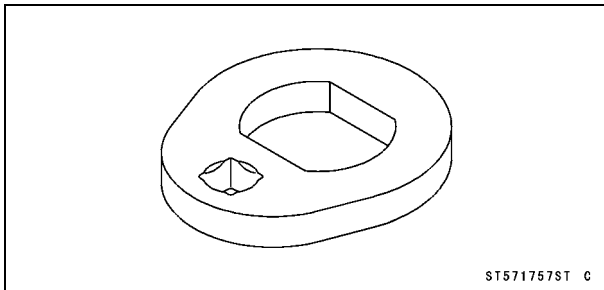

Parts Location

1. Timing Rotor
2. Crankshaft Sensor
3. Oxygen Sensor (Equipped Models)

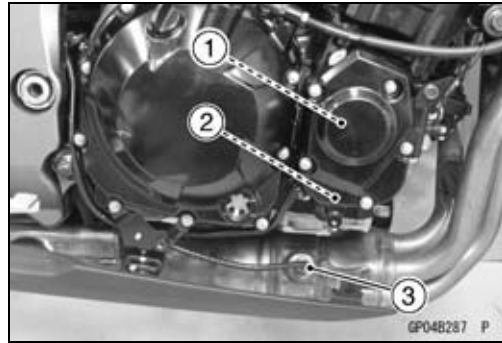

4. Horn
5. Turn Signal Relay

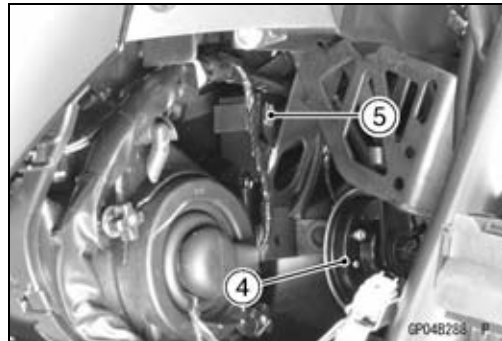

6. Relay Box
7. ECU

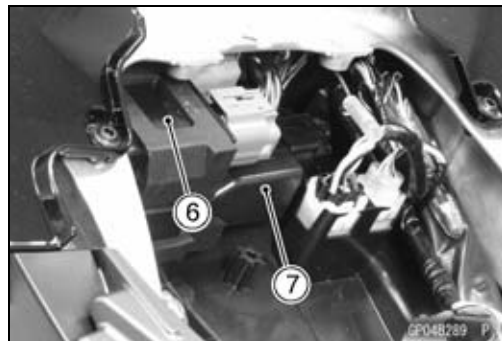

8. Rear Brake Light Switch



9. Regulator/Rectifier

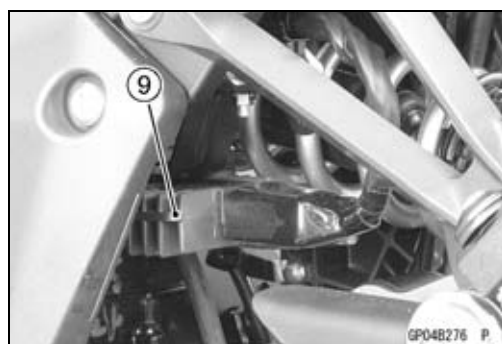

16-14 ELECTRICAL SYSTEM

Parts Location

- 10. Water Temperature Sensor
- 11. Speed Sensor
- 12. Alternator
- 13. Stator Coil
- 14. Radiator Fan Motor

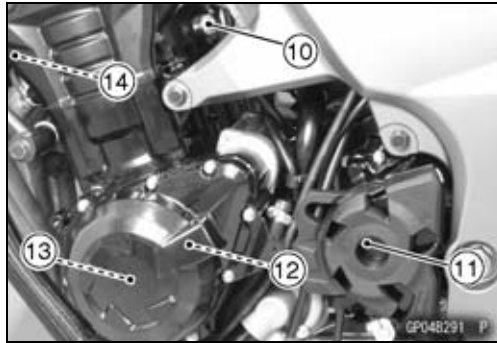

- 15. Neutral Switch
- 16. Oil Pressure Switch
- 17. Sidestand Switch



- 18. Fuse Boxes
- 19. Battery 12 V 8 Ah
- 20. Starter Relay

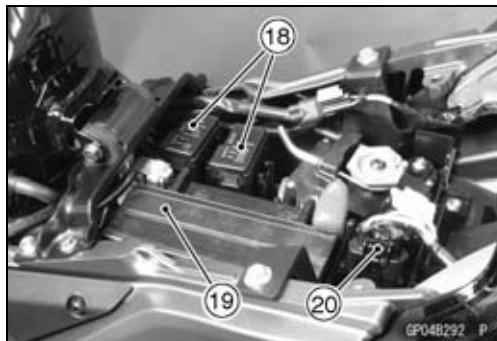

- 21. Air Switching Valve
- 22. Stick Coils
- 23. Spark Plugs

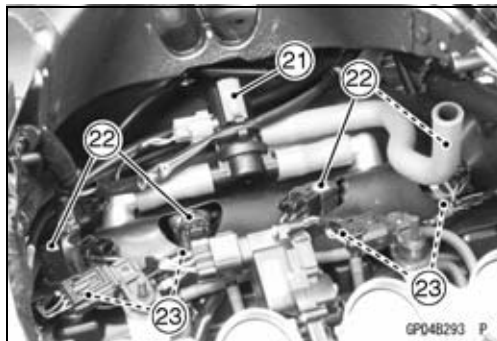

- 24. Immobilizer Amplifier (Immobilizer Models)



Parts Location

- 25. Starter Lockout Switch
- 26. Ignition Switch
(Immobilizer Model: Including Immobilizer Antenna)
- 27. Meter Unit
- 28. Front Brake Light Switch

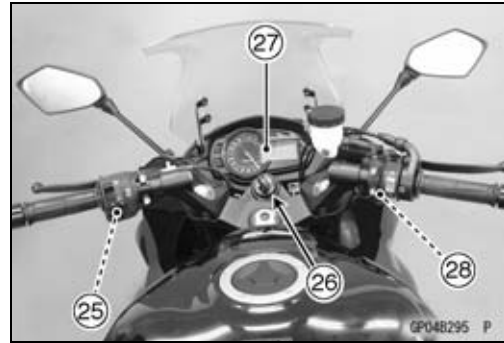

16-16 ELECTRICAL SYSTEM

Wiring Diagram (US, CA and CAL Models)

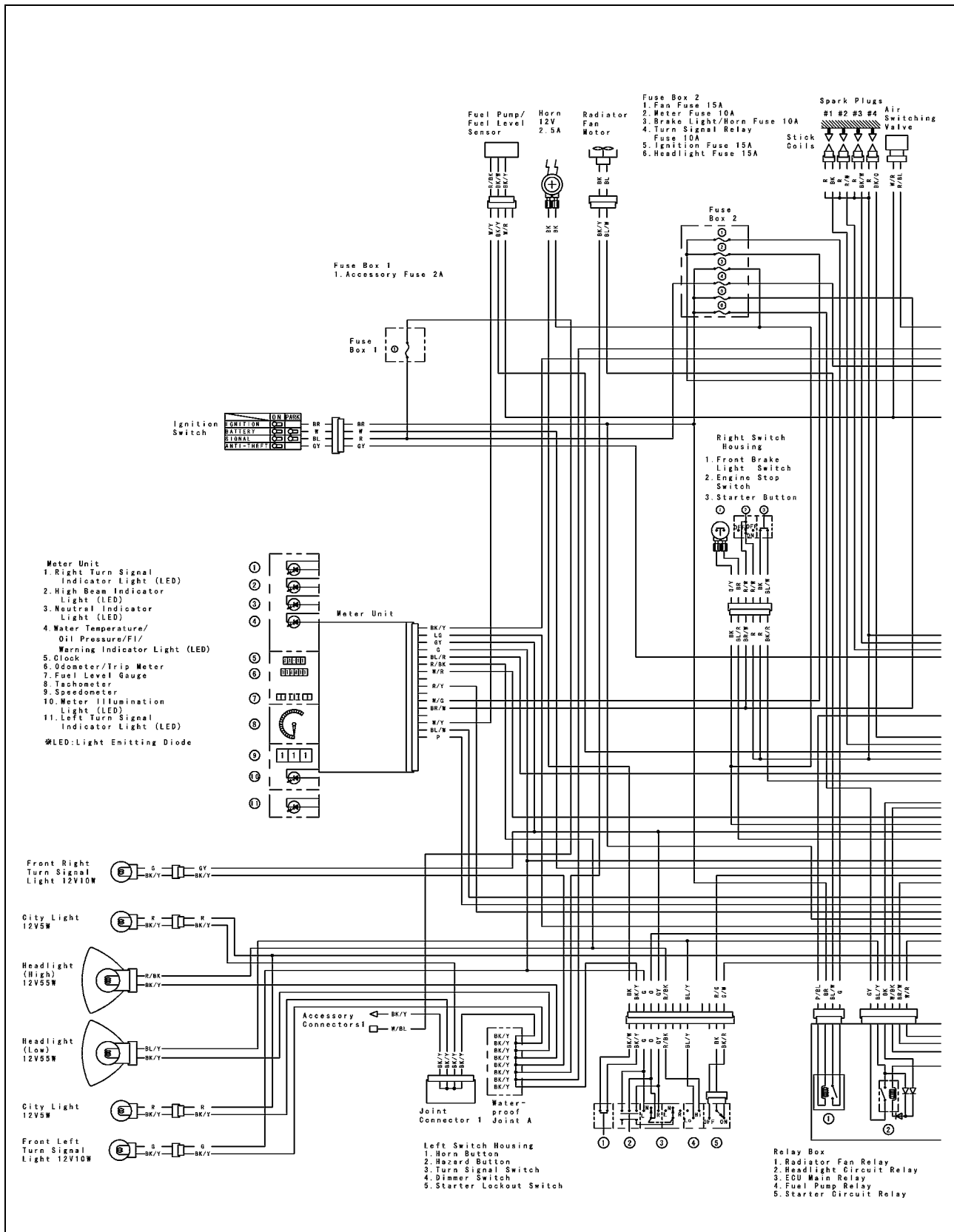

LEFT SWITCH HOUSING CONNECTIONS										
Horn Button	Hazard Button		Turn Signal Switch		Dimmer Switch		Starter Lockout Switch			
Color	BK/W	BK/Y	Color	G	O	GY	Color	R/BK	BL/Y	R/Y
Push	Push		OFF (Push)	L		GY	HI			Clutch Lever
		OFF (Push)		R			LO			Released
										Pulled in

Wiring Diagram (US, CA and CAL Models)

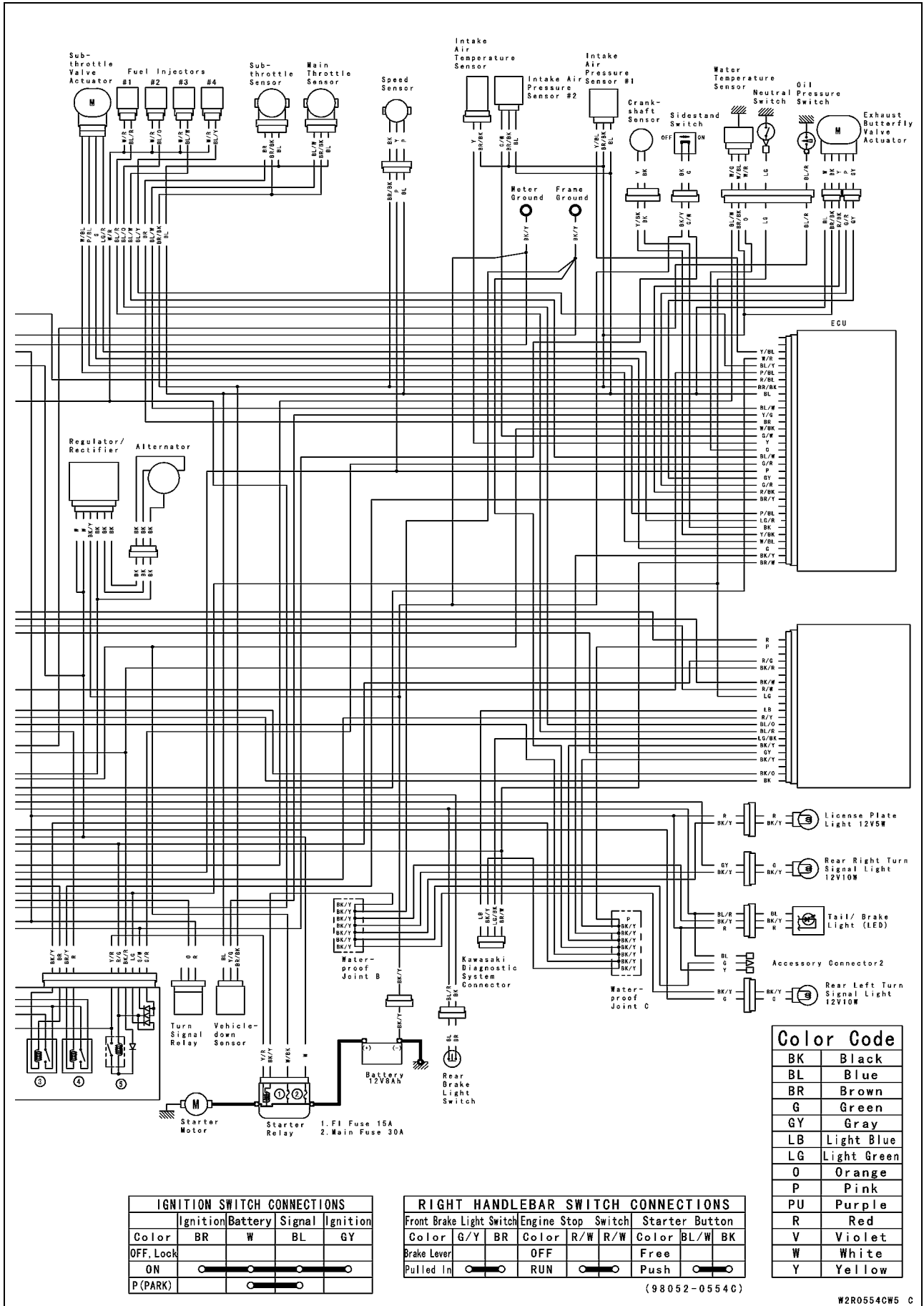

IGNITION SWITCH CONNECTIONS				
Color	Ignition	Battery	Signal	Ignition
OFF, Lock	BR	W	BL	GY
ON	—————●—————●—————●—————●—————			
P (PARK)	—————●—————●—————			

RIGHT HANDLEBAR SWITCH CONNECTIONS					
Front Brake Light Switch		Engine Stop Switch		Starter Button	
Color	G/Y	BR	Color	R/W	R/W
Color	BL/W	BK	Color	BL/W	BK
Brake Lever	●		OFF	●	
Pulled In	●		RUN	●	
			Push	●	

Color Code	
BK	Black
BL	Blue
BR	Brown
G	Green
GY	Gray
LB	Light Blue
LG	Light Green
O	Orange
P	Pink
PU	Purple
R	Red
V	Violet
W	White
Y	Yellow

(98052-0554C)

16-18 ELECTRICAL SYSTEM

Wiring Diagram (Other than US, CA and CAL Models)

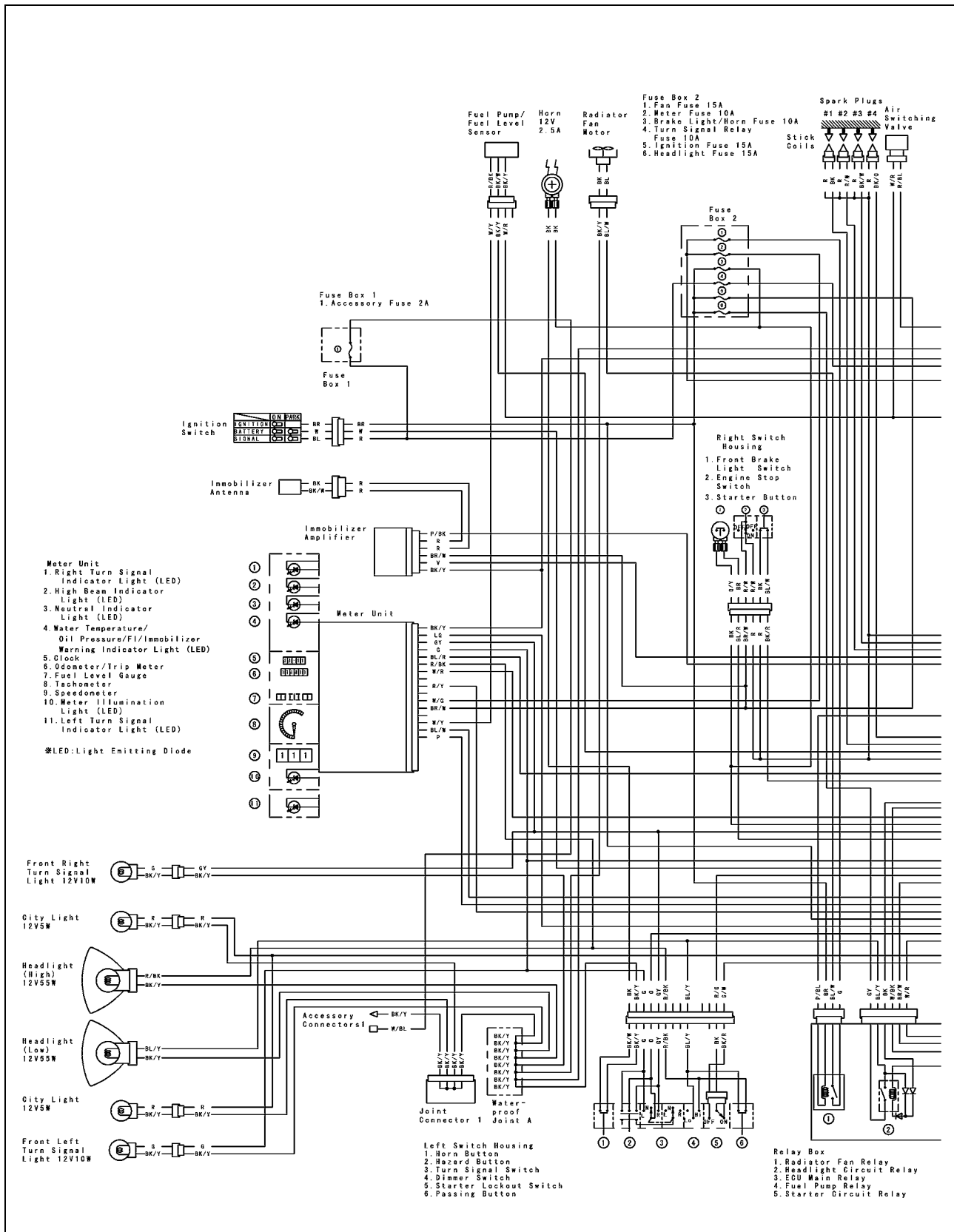

LEFT SWITCH HOUSING CONNECTIONS																	
Horn Button		Hazard Button		Turn Signal Switch		Dimmer Switch		Starter Lockout Switch		Passing Button							
Color	BK/WBK/Y	Color	G	O	GY	Color	G	O	GY	Color	R/BK/BL/Y	R/Y	Color	BK	BK/R	Color	R/BK/BL/Y
Push		Push			OFF (Push)	L			HI		Clutch Lever	Released	Push			Color	R/BK/BL/Y
		OFF (Push)			R				LO		Pulled in						

Wiring Diagram (Other than US, CA and CAL Models)

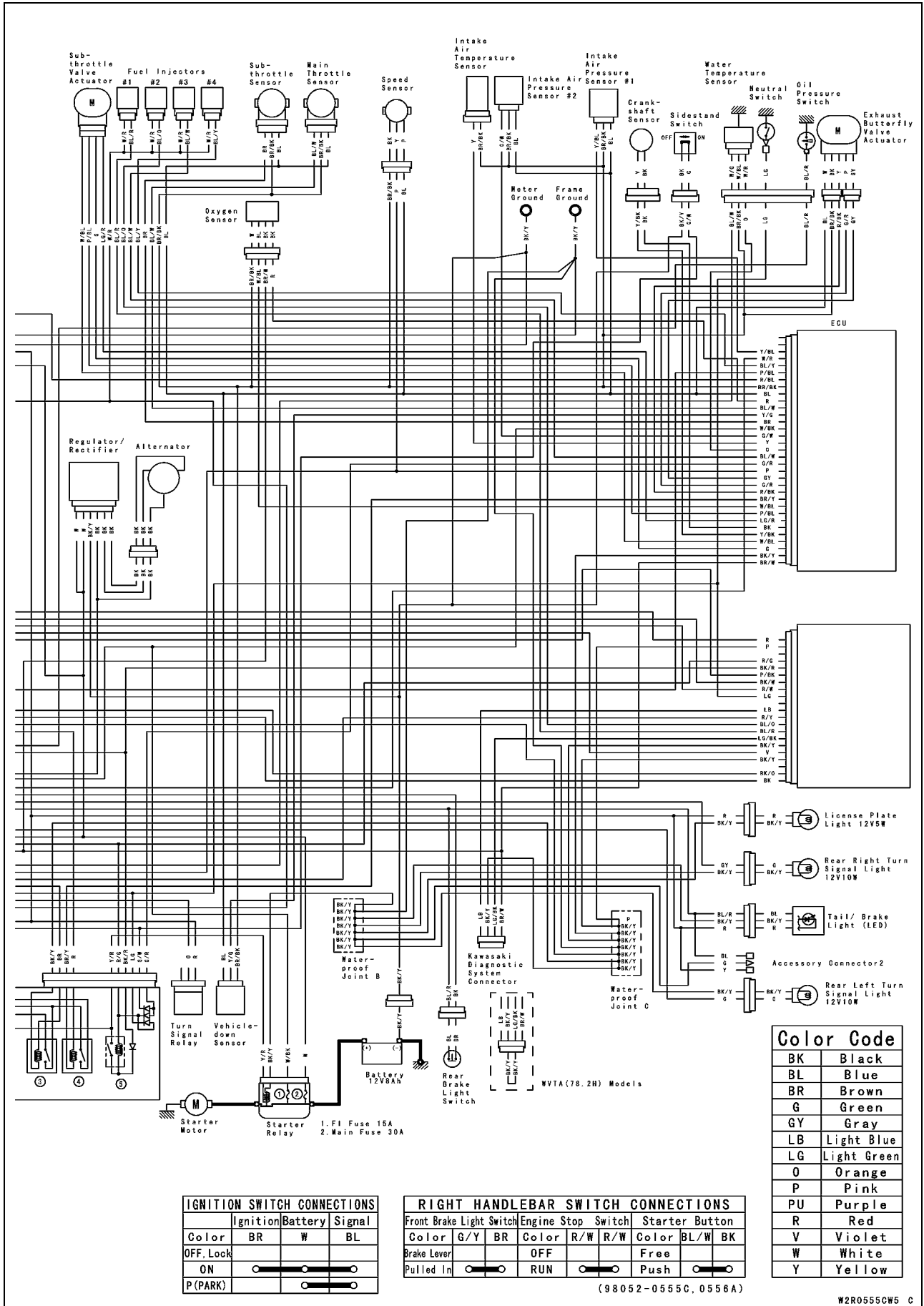

16-20 ELECTRICAL SYSTEM

Wiring Diagram (CA with ABS Models)

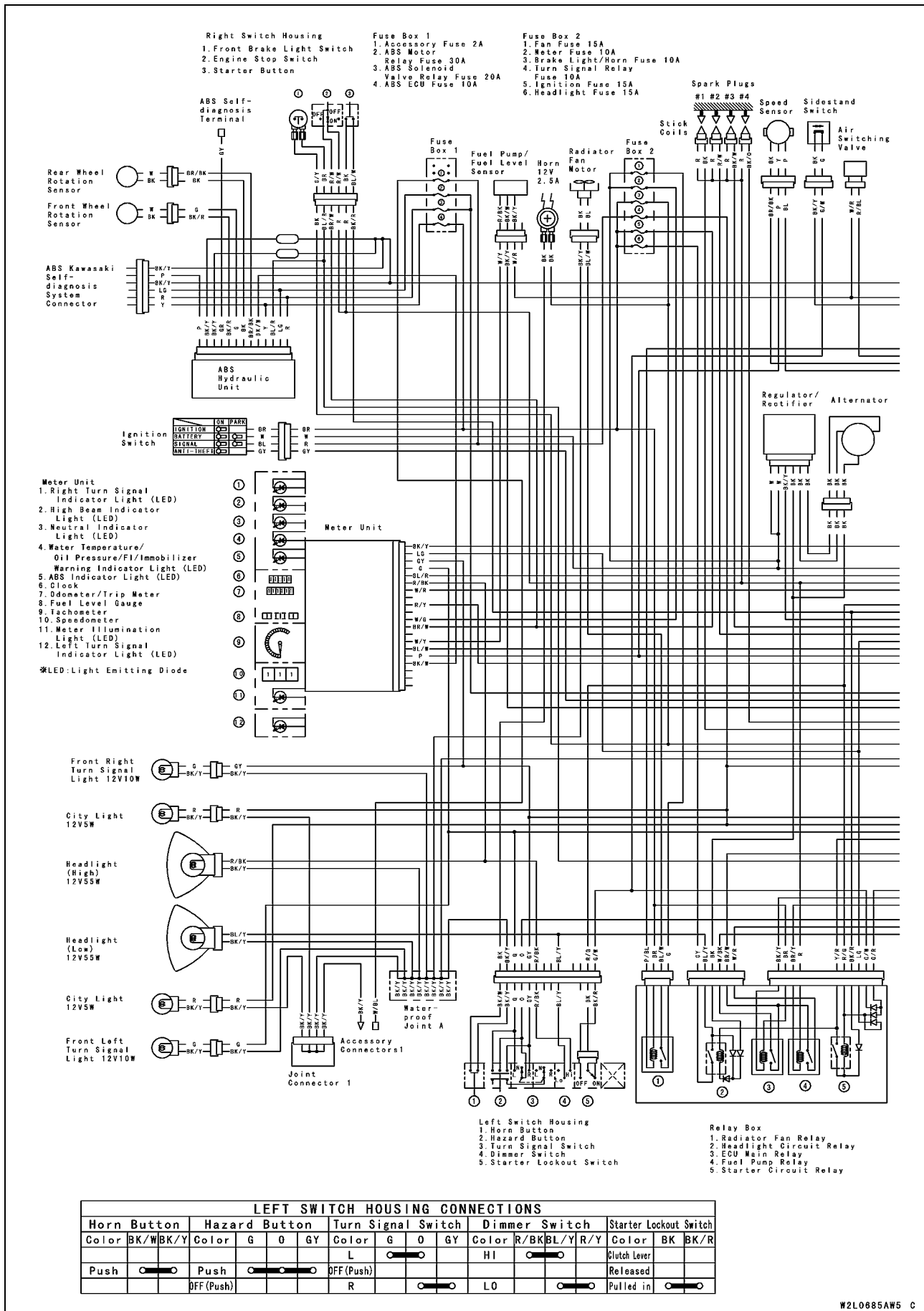

Wiring Diagram (CA with ABS Models)

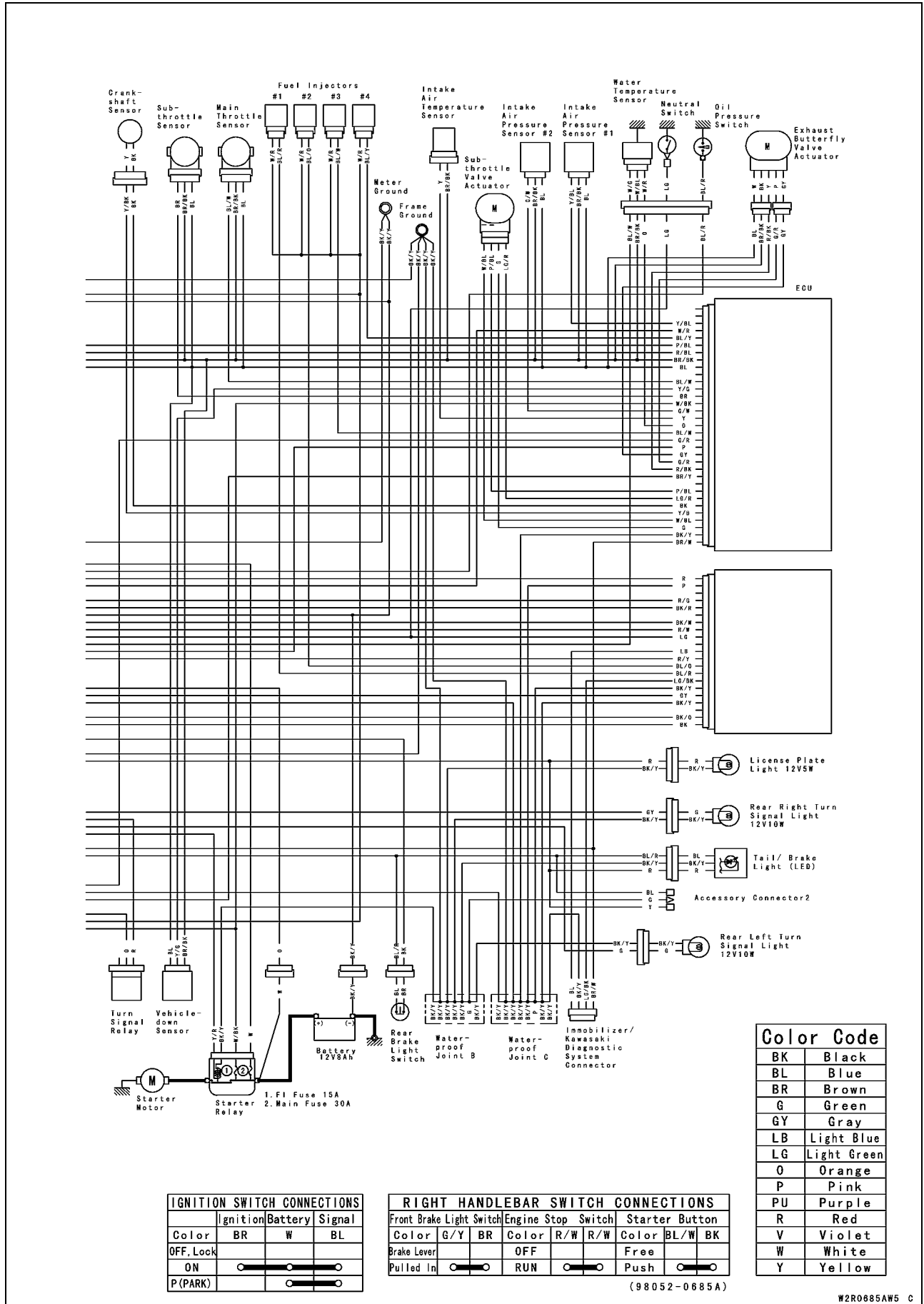

16-22 ELECTRICAL SYSTEM

Wiring Diagram (Other than CA with ABS Models)

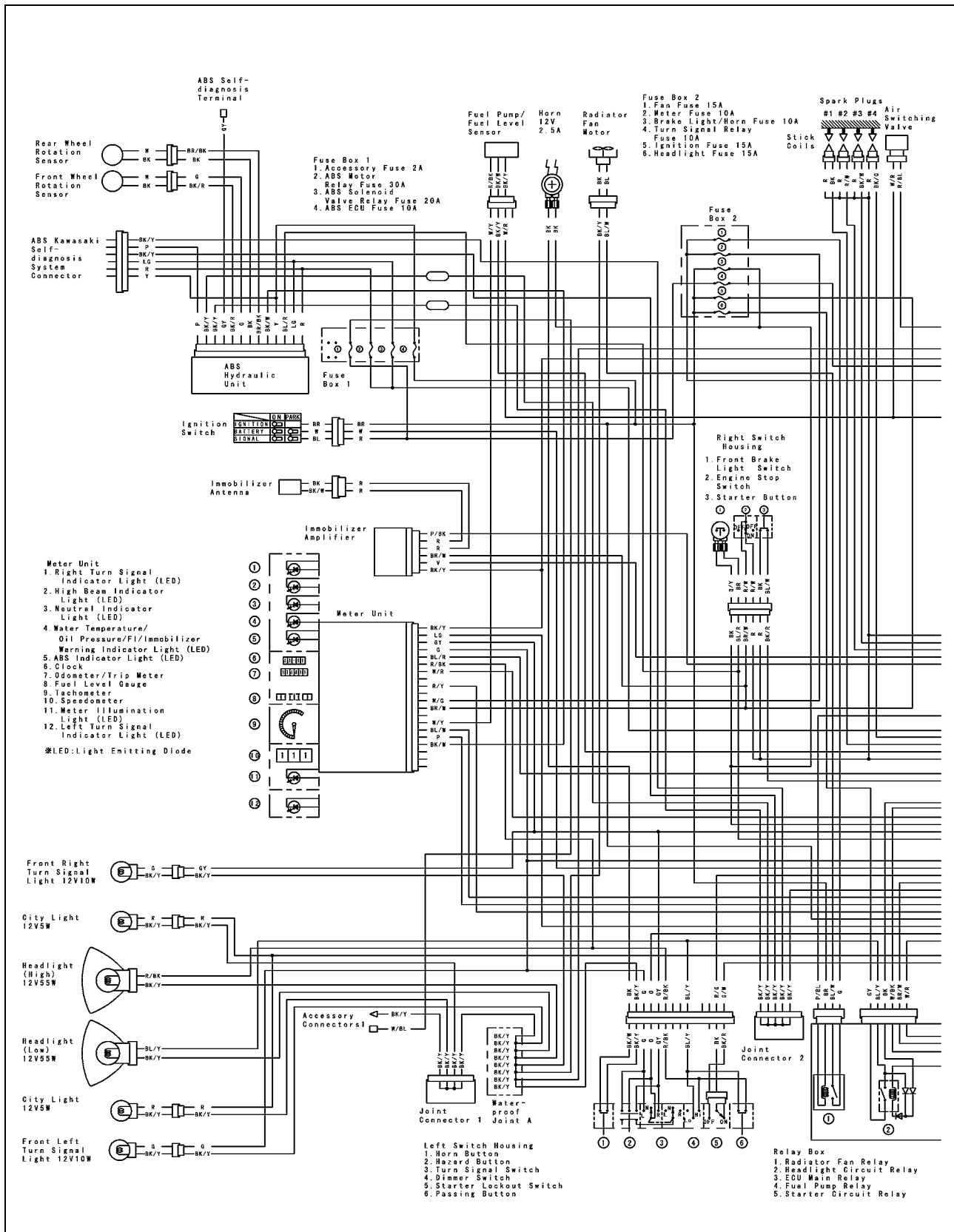

LEFT SWITCH HOUSING CONNECTIONS

Horn Button		Hazard Button		Turn Signal Switch		Dimmer Switch		Starter Lockout Switch		Passing Button	
Color	BK/WBK/Y	Color	G	O	GY	Color	R/BK/BL/Y	R/Y	Color	BK	BK/R
Push		Push		OFF (Push)		L		HI		Clutch Lever	Released
		OFF (Push)			R		LO			Pulled in	Push

Wiring Diagram (Other than CA with ABS Models)

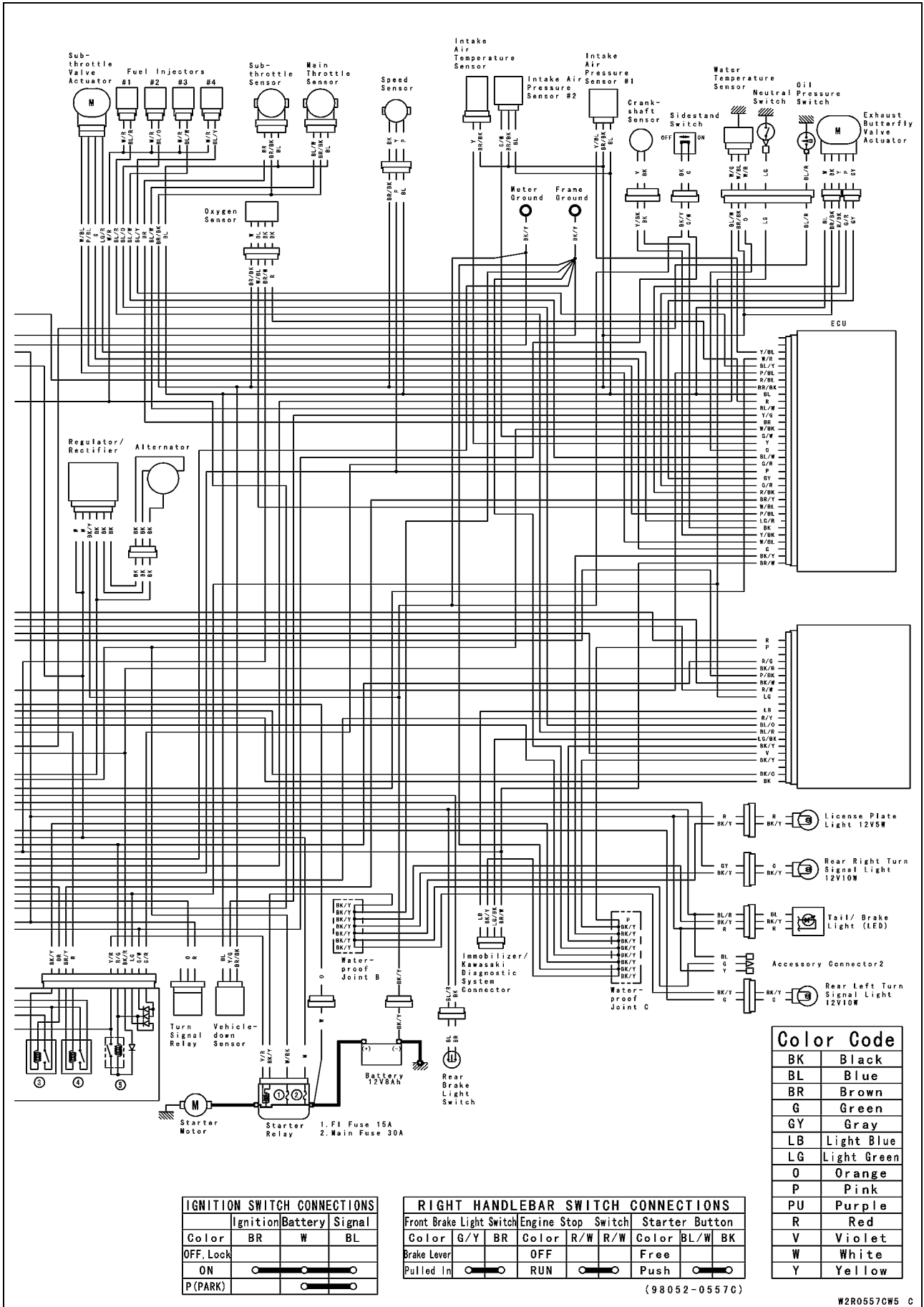

16-24 ELECTRICAL SYSTEM

Precautions

There are a number of important precautions that are musts when servicing electrical systems. Learn and observe all the rules below.

- Do not reverse the battery cable connections. This will burn out the diodes on the electrical parts.
- Always check battery condition before condemning other parts of an electrical system. A fully charged battery is a must for conducting accurate electrical system tests.
- The electrical parts should never be struck sharply, as with a hammer, or allowed to fall on a hard surface. Such a shock to the parts can damage them.
- To prevent damage to electrical parts, do not disconnect the battery cables or any other electrical connections when the ignition switch is ON, or while the engine is running.
- Because of the large amount of current, never keep the starter button pushed when the starter motor will not turn over, or the current may burn out the starter motor windings.
- Take care not to short the cables that are directly connected to the battery positive (+) terminal to the chassis ground.
- Troubles may involve one or in some cases all items. Never replace a defective part without determining what CAUSED the failure. If the failure was caused by some other item or items, they must be repaired or replaced, or the new replacement will soon fail again.
- Make sure all connectors in the circuit are clean and tight, and examine wires for signs of burning, fraying, etc. Poor wires and bad connections will affect electrical system operation.
- Measure coil and winding resistance when the part is cold (at room temperature).

Electrical Wiring

Wiring Inspection

- Visually inspect the wiring for signs of burning, fraying, etc.
- ★ If any wiring is poor, replace the damaged wiring.
- Pull each connector [A] apart and inspect it for corrosion, dirt, and damage.
- ★ If the connector is corroded or dirty, clean it carefully. If it is damaged, replace it.
- Check the wiring for continuity.
- Use the wiring diagram to find the ends of the lead which is suspected of being a problem.
- Connect the hand tester between the ends of the leads.

Special Tool - Hand Tester: 57001-1394

- Set the tester to the $\times 1 \Omega$ range, and read the tester.
- ★ If the tester does not read 0Ω , the lead is defective. Replace the lead or the wiring harness [B] if necessary.

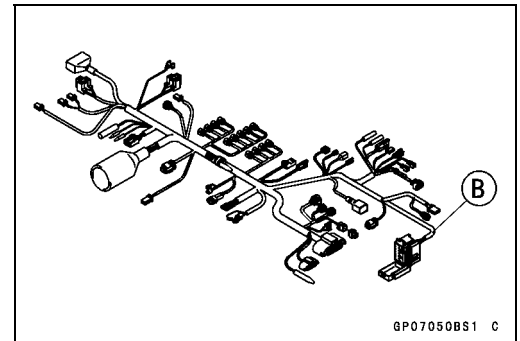
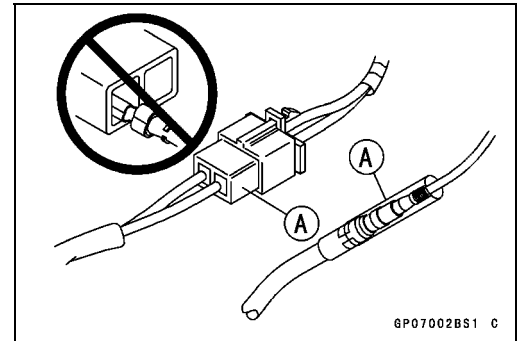

16-26 ELECTRICAL SYSTEM

Battery

Battery Removal

- Turn off the ignition switch.
- Remove:
 - Front Seat (see Front Seat Removal in the Frame chapter)
- Disconnect the negative (-) cable [A].

NOTICE

Be sure to disconnect the negative (-) cable first.

- Slide out the positive (+) terminal cap [B] and disconnect the positive (+) cable [C].
- Remove the battery.

Battery Installation

- Turn off the ignition switch.
- Put the battery into the battery case.
- Install the positive (+) cable [A] first.
- Install the negative (-) cable [B].
- Apply a light coat of grease on the terminals to prevent corrosion.
- Cover the Positive (+) terminal with the cap [C].

Battery Activation

Electrolyte Filling

- Make sure that the model name [A] of the electrolyte container matches the model name [B] of the battery. These names must be the same.

Battery Model Name

ZX1000G/H: YTX9-BS

NOTICE

Each battery comes with its own specific electrolyte container; using the wrong container may overfill the battery with incorrect electrolyte, which can shorten battery life and deteriorate battery performance. Be sure to use the electrolyte container with the same model name as the battery since the electrolyte volume and specific gravity vary with the battery type.

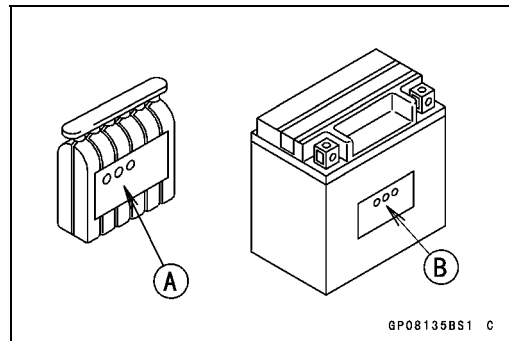
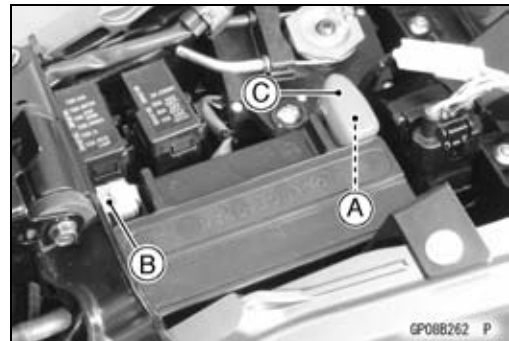
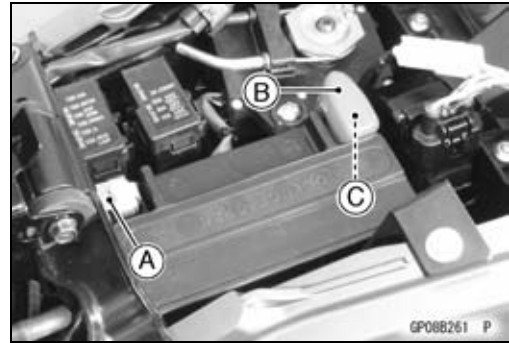

Battery

NOTICE

Do not remove the aluminum sealing sheet [A] from the filler ports [B] until just prior to use. Be sure to use the dedicated electrolyte container for correct electrolyte volume.

⚠ DANGER

Sulfuric acid in battery electrolyte can cause severe burns. To prevent burns, wear protective clothing and safety glasses when handling electrolyte. If the electrolyte comes in contact with your skin or eyes, wash the area with liberal amounts of water and seek medical attention for more severe burns.

- Place the battery on a level surface.
- Check to see that the sealing sheet has no peeling, tears, or holes in it.
- Remove the sealing sheet.

NOTE

○ The battery is vacuum sealed. If the sealing sheet has leaked air into the battery, it may require a longer initial charge.

- Remove the electrolyte container from the vinyl bag.
- Detach the strip of caps [A] from the container and set aside, these will be used later to seal the battery.

NOTE

○ Do not pierce or otherwise open the sealed cells [B] of the electrolyte container. Do not attempt to separate individual cells.

- Place the electrolyte container upside down with the six sealed cells into the filler ports of the battery. Hold the container level, push down to break the seals of all six cells. You will see air bubbles rising into each cell as the ports fill.

NOTE

○ Do not tilt the electrolyte container.

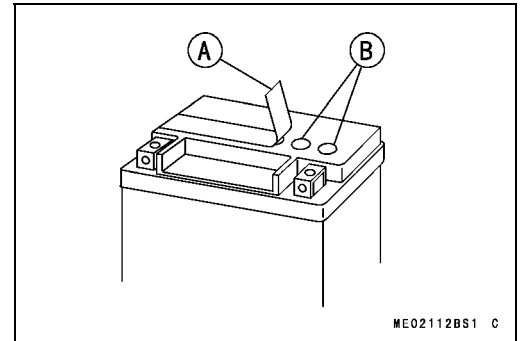

ME02112BS1 C

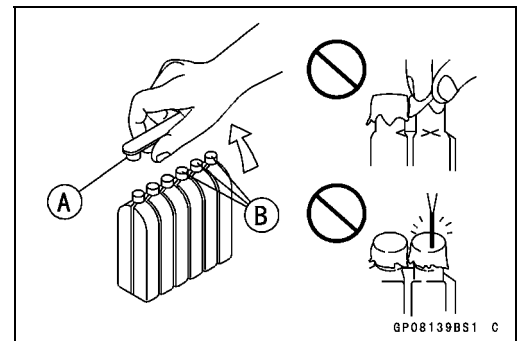

GP08139BS1 C

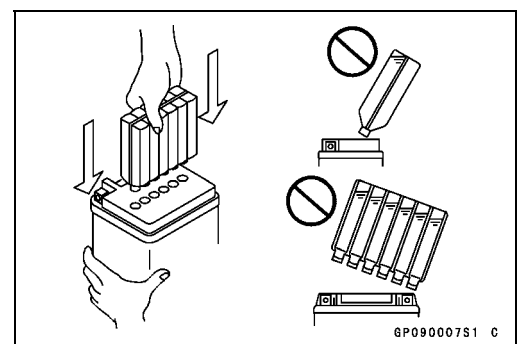

GP090007S1 C

16-28 ELECTRICAL SYSTEM

Battery

- Check the electrolyte flow.
- ★ If no air bubbles [A] are coming up from the filler ports, or if the container cells have not emptied completely, tap the container [B] a few times.

NOTE

○ Be careful not to have the battery fall down.

- Keep the container in place. Don't remove the container from the battery, the battery requires all the electrolyte from the container for proper operation.

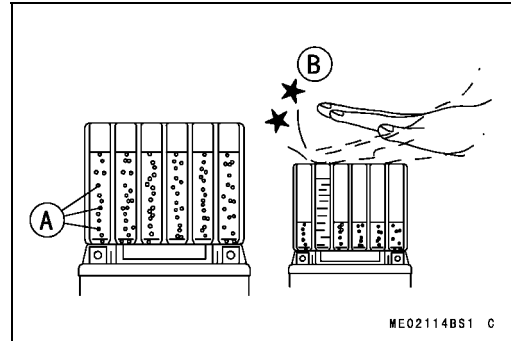

NOTICE

Removal of the container before it is completely empty can shorten the service life of the battery. Do not remove the container until it is completely empty.

- After filling, let the battery sit for 20 ~ 60 minutes with the electrolyte container kept in place, which is required for the electrolyte to fully permeate into the plates.
- Make sure that the container cells have emptied completely, and remove the container from the battery.
- Place the strip of caps [A] loosely over the filler ports, press down firmly with both hands to seat the strip of caps into the battery (don't pound or hammer). When properly installed, the strip of caps will be level with the top of the battery.

NOTICE

Once the strip of caps is installed onto the battery, never remove the caps, nor add water or electrolyte to the battery.

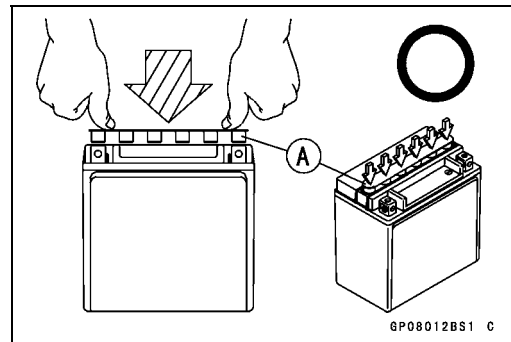

NOTE

○ Charging the battery immediately after filling can shorten service life.

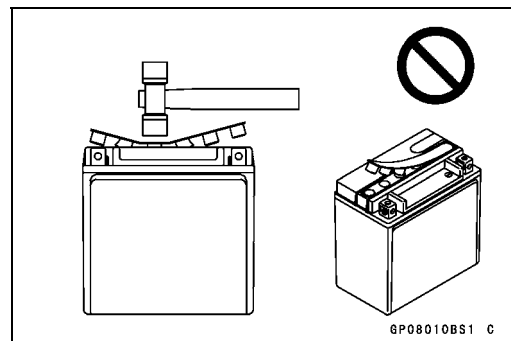

Battery

Initial Charge

- Newly activated sealed batteries require an initial charge.

Standard Charge: 0.9 A × 5 ~ 10 hours

- ★ If using a recommended battery charger, follow the charger's instructions for newly activated sealed battery.

Kawasaki-recommended chargers:

Battery Mate 150-9

OptiMate PRO 4-S/PRO S/PRO2

Yuasa MB-2040/2060

Christie C10122S

- ★ If the above chargers are not available, use equivalent one.
- Let battery sit 30 minutes after initial charge, then check voltage using a voltmeter. (Voltage immediately after charging becomes temporarily high. For accurate measuring, let the battery sit for given time.)

NOTE

- *Charging rates will vary depending on how long the battery has been stored, temperature, and the type of charger used. If voltage is not at least 12.8 V, repeat charging cycle.*
- *To ensure maximum battery life and customer satisfaction, it is recommended the battery be load tested at three times its amp-hour rating for 15 seconds. Re-check voltage and if less than 12.8 V repeat the charging cycle and load test. If still below 12.8 V the battery is defective.*

Precautions

- 1) No need of topping-up
No topping-up is necessary in this battery until it ends its life under normal use. Forcibly prying off the seal cap to add water is very dangerous. Never do that.
- 2) Refreshing charge.
If an engine will not start, a horn sounds weak, or lamps are dim, it indicates the battery has been discharged. Give refresh charge for 5 to 10 hours with charge current shown in the specification (see Refreshing Charge).
When a fast charge is inevitably required, do it following precisely the maximum charge current and time conditions indicated on the battery.

NOTICE

This battery is designed to sustain no unusual deterioration if refresh-charged according to the method specified above. However, the battery's performance may be reduced noticeably if charged under conditions other than given above. Never remove the seal cap during refresh charge.

If by chance an excessive amount of gas is generated due to overcharging, the relief valve releases the gas to keep the battery normal.

- 3) When you do not use the motorcycle for months.
Give a refresh charge before you store the motorcycle and store it with the negative cable removed. Give a refresh charge **once a month** during storage.
- 4) Battery life.
If the battery will not start the engine even after several refresh charges, the battery has exceeded its useful life. Replace it (Provided, however, the vehicle's starting system has no problem).

16-30 ELECTRICAL SYSTEM

Battery

⚠ DANGER

Batteries produce an explosive gas mixture of hydrogen and oxygen that can cause serious injury and burns if ignited. Keep the battery away from sparks and open flames during charging. When using a battery charger, connect the battery to the charger before turning on the charger. This procedure prevents sparks at the battery terminals which could ignite any battery gases. The electrolyte contains sulfuric acid. Be careful not to have it touch your skin or eyes. If touched, wash it off with liberal amount of water and seek medial attention for more severe burns.

Interchange

A sealed battery can fully display its performance only when combined with a proper vehicle electric system. Therefore, replace a sealed battery only on a motorcycle which was originally equipped with a sealed battery.

Be careful, if a sealed battery is installed on a motorcycle which had an ordinary battery as original equipment, the sealed battery's life will be shortened.

Charging Condition Inspection

○ Battery charging condition can be checked by measuring battery terminal voltage with a digital voltmeter [A].

● Remove:

Seats (see Seats section in the Frame chapter)

● Disconnect the battery terminals.

NOTICE

Be sure to disconnect the negative (-) cable first.

● Measure the battery terminal voltage.

NOTE

○ Measure with a digital voltmeter which can be read one decimal place voltage.

★ If the reading is 12.8 V or more, no refresh charge is required, however, if the read is below the specified, refresh charge is required.

Battery Terminal Voltage

Standard: 12.8 V or more

Terminal Voltage (V) [A]

Battery Charge Rate (%) [B]

Good [C]

Refresh charge is required [D]

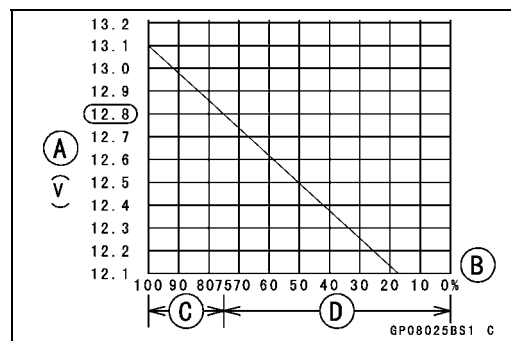
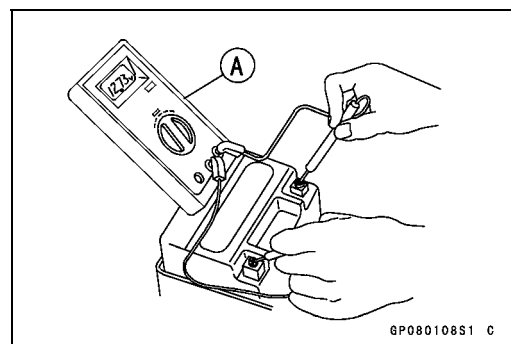

Refreshing Charge

● Remove the battery [A] (see Battery Removal).

● Do refresh charge by following method according to the battery terminal voltage.

⚠ WARNING

This battery is sealed type. Never remove sealing cap [B] even at charging. Never add water. Charge with current and time as stated below.

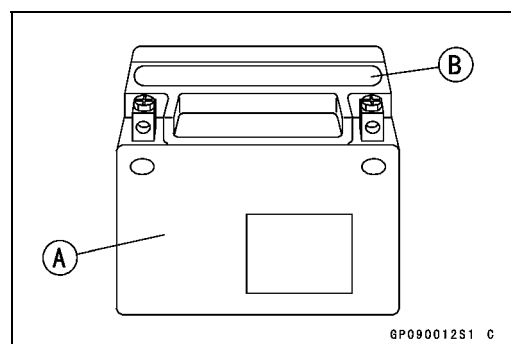

Battery

Terminal Voltage: 11.5 ~ less than 12.8 V

- Standard Charge:** 0.9 A x 5 ~ 10 h (see following chart)
- Quick Charge:** 4 A x 1 h

NOTICE

If possible, do not quick charge. If quick charge is done unavoidably, do standard charge later on.

Terminal Voltage: less than 11.5 V
Charging Method: 0.9 A x 20 h

NOTE

- Increase the charging voltage to a maximum voltage of 25 V if the battery will not accept current initially. Charge for no more than 5 minutes at the increased voltage then check if the battery is drawing current. If the battery will accept current decrease the voltage and charge by the standard charging method described on the battery case. If the battery will not accept current after 5 minutes, replace the battery.

- Battery [A]
- Battery Charger [B]
- Standard Value [C]
- Current starts to flow [D]

- Determine the battery condition after refresh charge.
- Determine the condition of the battery left for 30 minutes after completion of the charge by measuring the terminal voltage according to the table below.

Criteria	Judgement
12.8 V or higher	Good
12.0 ~ lower than 12.8 V	Charge insufficient → Recharge
lower than 12.0 V	Unserviceable → Replace

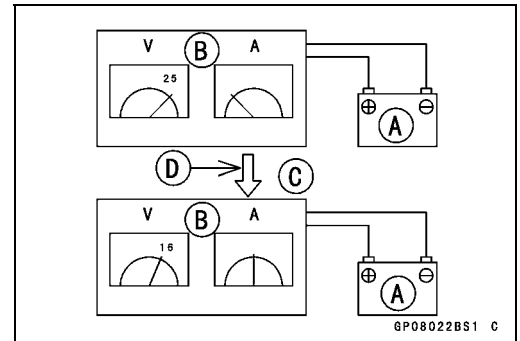
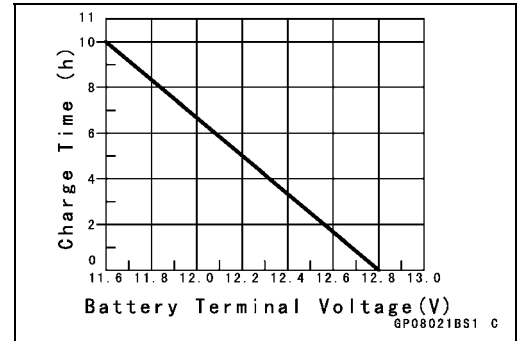

16-32 ELECTRICAL SYSTEM

Charging System

Alternator Cover Removal

- Remove:
 - Left Lower Fairing (see Lower Fairing Removal in the Frame chapter)
- Support the fuel tank with a suitable bar (see Fuel Tank Removal in the Fuel System (DFI) chapter).
- Pull up the connector bracket [A].
- Remove the alternator lead connector [B] from the bracket.
- Disconnect the alternator lead connector.

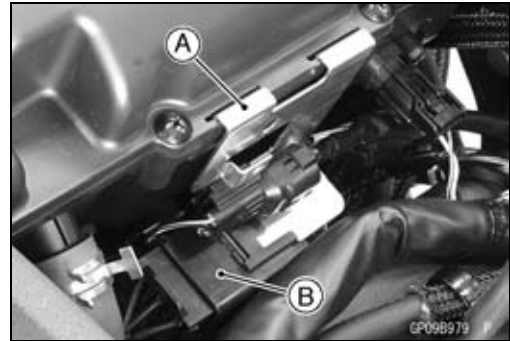

- Place a suitable container under the alternator cover [A].
- Remove:
 - Alternator Cover Bolts [B]
 - Bracket [C]
 - Alternator Cover

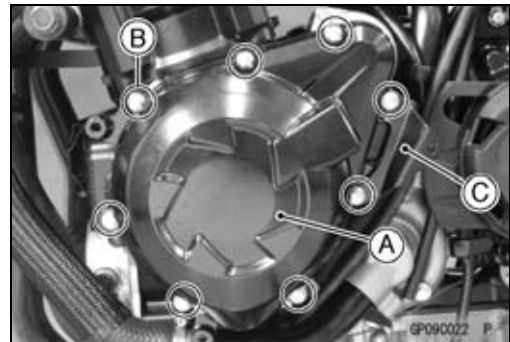

Alternator Cover Installation

- Apply silicone sealant to the alternator lead grommet and crankcase halves mating surface [A] on the front and rear sides of the cover mount.

Sealant - Liquid Gasket, TB1211F: 92104-0004

- Check that dowel pins [B] are in place on the crankcase.
- Install a new gasket and the alternator cover.
- Tighten:

Torque - Alternator Cover Bolts: 12 N·m (1.2 kgf·m, 106 in·lb)

- Run the alternator lead correctly (see Cable, Wire, and Hose Routing section in the Appendix chapter).
- Confirm that the drain hose and clamp are installed securely and run the hose correctly (see Cable, Wire, and Hose Routing section in the Appendix chapter).

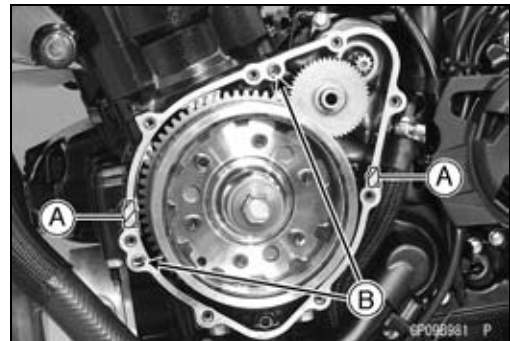

Charging System

Stator Coil Removal

- Remove:
 - Alternator Cover (see Alternator Cover Removal)
 - Holding Plate Bolt [A] and Plate
 - Alternator Lead Grommet [B]
 - Stator Coil Bolts [C]
- Remove the stator coil [D] from the alternator cover.

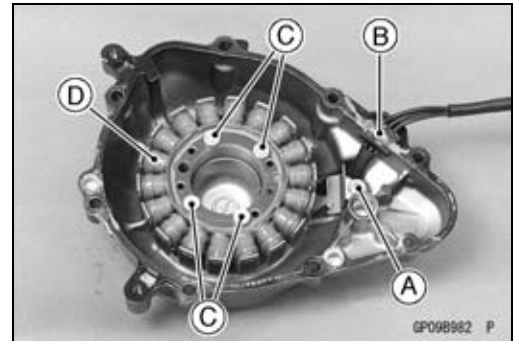

Stator Coil Installation

- Apply a non-permanent locking agent to the threads of the stator coil bolts and tighten them.

Torque - Stator Coil Bolts: 12 N·m (1.2 kgf·m, 106 in·lb)

- Secure the alternator lead with a holding plate.
- Apply a non-permanent locking agent to the threads of the plate bolt and tighten it.

Torque - Alternator Lead Holding Plate Bolt: 12 N·m (1.2 kgf·m, 106 in·lb)

- Apply silicone sealant to the circumference of the alternator lead grommet [A], and fit the grommet into the notch [B] of the cover securely.

Sealant - Liquid Gasket, TB1211F: 92104-0004

- Install the alternator cover (see Alternator Cover Installation).

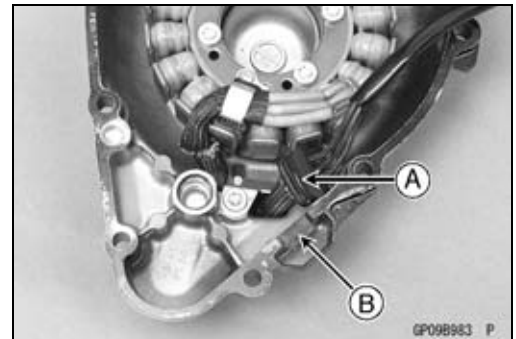

Alternator Rotor Removal

- Remove:
 - Alternator Cover (see Alternator Cover Removal)
 - Starter Idle Gear [A]



- Hold the alternator rotor steady with the rotor holder [A] and stopper [B].
- Remove the rotor bolt [C] and washer.

Special Tools - Grip [D]: 57001-1591

Stopper: 57001-1679

Rotor Holder: 57001-1690

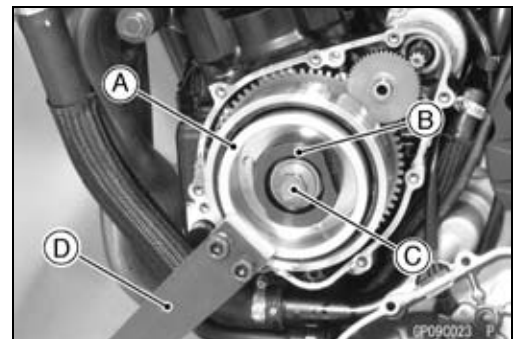

16-34 ELECTRICAL SYSTEM

Charging System

If using the rotor holder (57001-1757).

- Hold the alternator rotor steady with the rotor holder [A].
- Remove the rotor bolt [B] and washer.

Special Tool - Rotor Holder: 57001-1757

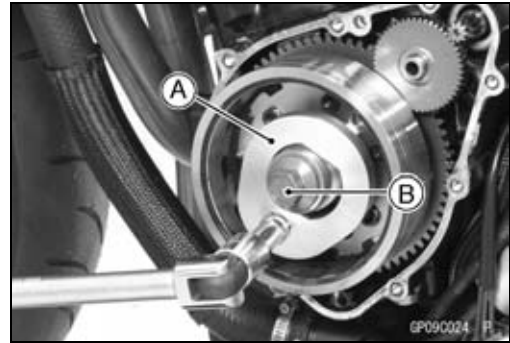

- Using the flywheel puller [A], remove the alternator rotor [B] from the crankshaft.

Special Tool - Flywheel Puller Assembly, M38 x 1.5/M35 x 1.5: 57001-1615

NOTICE

Do not attempt to strike the alternator rotor itself. Striking the rotor can cause the magnets to lose their magnetism.



Alternator Rotor Installation

- Apply a thin coat of molybdenum disulfide grease to the crankshaft [A] and the outer surface [B] of the starter clutch gear [C].

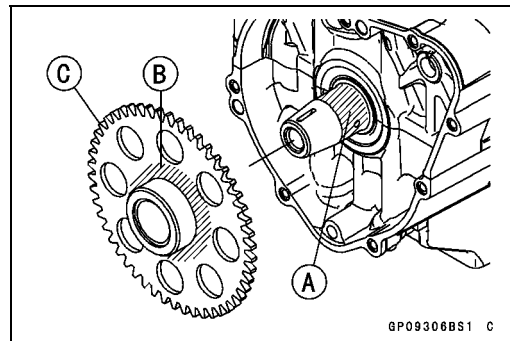

- Install the starter clutch gear [A].
- Using a cleaning fluid, clean off any oil or dirt on the following portions and dry them with a clean cloth.
 - Crankshaft Tapered Portion [B]
 - Alternator Rotor Tapered Portion [C]
- Fit the woodruff key [D] securely in the slot in the crankshaft before installing the alternator rotor.



- Install the alternator rotor [A] while turning [B] the starter clutch gear [C] clockwise.



Charging System

- Using a cleaning fluid, clean off any oil or dirt on the washer [A] and dry it with a clean cloth.
- Install the washer.

NOTE

○ Confirm the alternator rotor fit or not to the crankshaft before tightening it with specified torque.

- Install the rotor bolt [B] and tighten it with 70 N·m (7.0 kgf·m, 52 ft·lb) of torque.

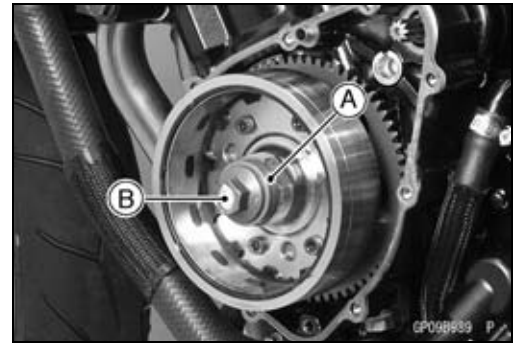

- Remove the rotor bolt and washer.
- Check the tightening torque with flywheel puller [A].

Special Tool - Flywheel Puller Assembly, M38 x 1.5/M35 x 1.5: 57001-1615

- ★ If the rotor is not pulled out with 20 N·m (2.0 kgf·m, 15 ft·lb) of drawing torque, it is installed correctly.
- ★ If the rotor is pulled out with under 20 N·m (2.0 kgf·m, 15 ft·lb) of drawing torque, clean off any oil dirt or flaw of the crankshaft and rotor tapered portion, and dry them with a clean cloth. Then, confirm that it is not pulled out with above torque.

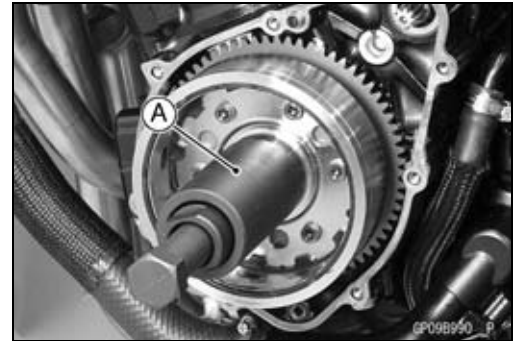

- Install the washer and rotor bolt.
- Tighten the alternator rotor bolt [A] while holding the alternator rotor steadily with the holder [B].

Special Tools - Grip [C]: 57001-1591
Rotor Holder: 57001-1690
Stopper [D]: 57001-1679

Torque - Alternator Rotor Bolt: 155 N·m (15.8 kgf·m, 114 ft·lb)

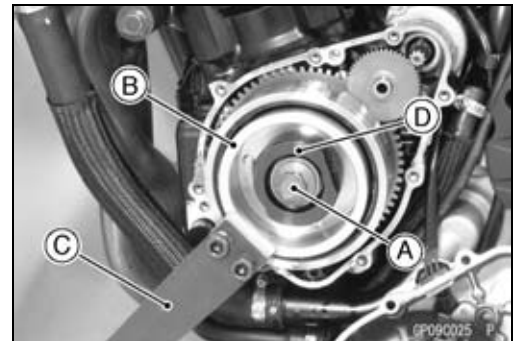

If using rotor holder (57001-1757).

- Install the washer and rotor bolt.
- Tighten the alternator rotor bolt [A] while holding the alternator rotor steadily with the holder [B].

Special Tool - Rotor Holder: 57001-1757

Torque - Alternator Rotor Bolt: 155 N·m (15.8 kgf·m, 114 ft·lb)

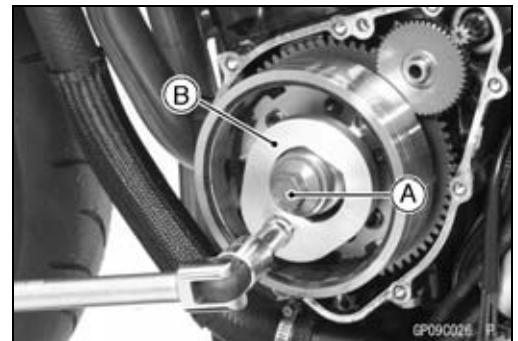

16-36 ELECTRICAL SYSTEM

Charging System

- Apply a thin coat of molybdenum disulfide grease to the shaft [A], and install it and starter idle gear [B].
- Install the alternator cover (see Alternator Cover Installation).

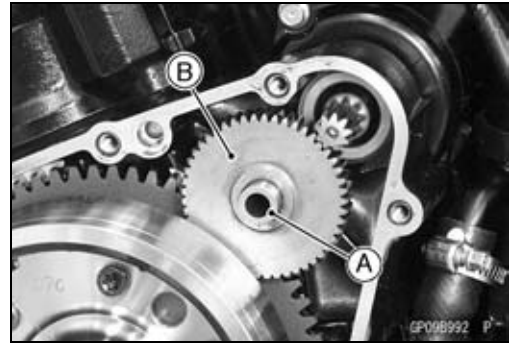

Alternator Inspection

There are three types of alternator failures: short, open (wire burned out), or loss in rotor magnetism. A short or open in one of the coil wires will result in either a low output, or no output at all. A loss in rotor magnetism, which may be caused by dropping or hitting the alternator, by leaving it near an electromagnetic field, or just by aging, will result in low output.

- To check the alternator output voltage, do the following procedures.
 - Turn off the ignition switch.
 - Disconnect the alternator lead connector [A] (see alternator Cover Removal).
 - Connect the hand tester as shown in the table 1.
 - Start the engine.
 - Run it at the rpm given in the table 1.
 - Note the voltage readings (total 3 measurements).

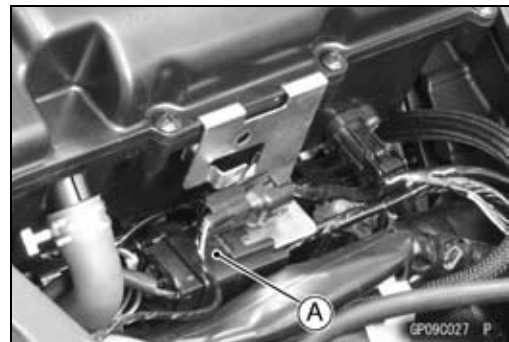

Table 1 Alternator Output Voltage

Tester Range	Connections		Reading at 4 000 rpm
	Tester (+) to	Tester (-) to	
250 V AC	One Black lead	Another Black lead	43 V or more

- ★ If the output voltage shows the value in the table, the alternator operates properly.
- ★ If the output voltage shows a much higher than the value in the table, the regulator/rectifier is damaged. A much lower reading than that given in the table indicates that the alternator is defective.
- Check the stator coil resistance as follows.
 - Stop the engine.
 - Connect the hand tester as shown in the table 2.
 - Note the readings (total 3 measurement).

Table 2 Stator Coil Resistance at 20°C (68°F)

Tester Range	Connections		Reading
	Tester (+) to	Tester (-) to	
$\times 1 \Omega$	One Black lead	Another Black lead	0.18 ~ 0.28 Ω

Charging System

- ★ If there is more resistance than shown in the table, or no hand tester reading (infinity) for any two leads, the stator has an open lead and must be replaced. Much less than this resistance means the stator is shorted, and must be replaced.
- Using the highest resistance range of the hand tester, measure the resistance between each of the black leads and chassis ground.
- ★ Any hand tester reading less than infinity (∞) indicates a short, necessitating stator replacement.
- ★ If the stator coils have normal resistance, but the voltage check showed the alternator to be defective; then the rotor magnets have probably weakened, and the rotor must be replaced.

Special Tool - Hand Tester: 57001-1394

Regulator/Rectifier Inspection

ZX1000G Model

- Remove:
 - Bolts [A] and Nuts [B]
 - Connector [C] (Disconnect)
 - Regulator/Rectifier [D]

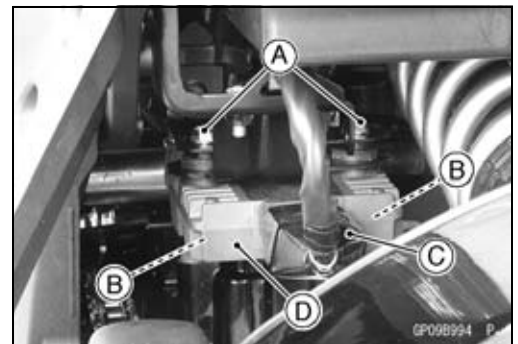

ZX1000H Model

- Remove:
 - ABS Hydraulic Unit (see ABS Hydraulic Unit Removal in the Brakes chapter)
 - Bolts [A] and Nuts [B]
 - Regulator/Rectifier [C]

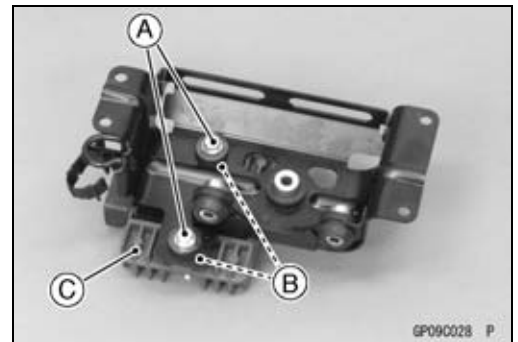

Rectifier Circuit Check

- Check conductivity of the following pair of terminals.

Rectifier Circuit Inspection

Tester connection	W1-BK1,	W1-BK2,	W1-BK3
	BK/Y-BK1,	BK/Y-BK2,	BK/Y-BK3

- ★ The resistance should be low in one direction and more than ten times as much in the other direction. If any two terminals are low or high in both directions, the rectifier is defective and the regulator/rectifier must be replaced.

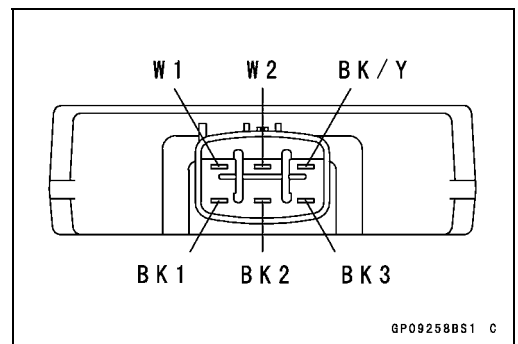

NOTE

○ The actual meter reading varies with the meter used and the individual rectifier, but, generally speaking the lower reading should be from zero to one half the scale.

16-38 ELECTRICAL SYSTEM

Charging System

Regulator Circuit Check

To test the regulator out of circuit, use three 12 V batteries and a test light (12 V 3 ~ 6 W bulb in a socket with leads).

NOTICE

The test light works as an indicator and also a current limiter to protect the regulator/rectifier from excessive current. Do not use an ammeter instead of a test light.

- Check to be sure the rectifier circuit is normal before continuing.
- Do the 1st step regulator circuit test.
 - Connect the test light and the 12 V battery to the regulator/rectifier as shown in the figure.
 - Check the BK1, BK2 and BK3 terminal respectively.
 - ★ If the test light turns on, the regulator/rectifier is defective. Replace it.
 - ★ If the test light does not turn on, continue the test.

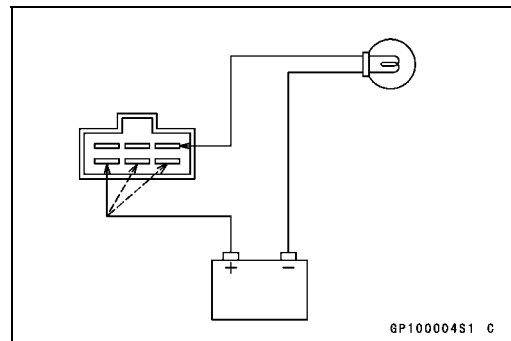

- Do the 2nd step regulator circuit test.
 - Connect the test light and the 12 V battery in the same manner as specified in the “Regulator Circuit Test-1st Step”.
 - Apply 12 V to the W2 terminal.
 - Check the BK1, BK2 and BK3 terminal respectively.
 - ★ If the test light turns on, the regulator/rectifier is defective. Replace it.
 - ★ If the test light does not turn on, continue the test.

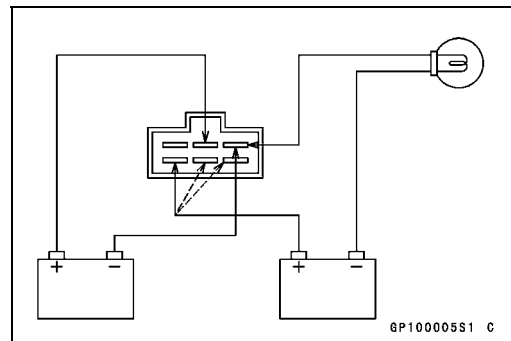

- Do the 3rd step regulator circuit test.
 - Connect the test light and the 12 V battery in the same manner as specified in the “Regulator Circuit Test-1st Step”.
 - Momentarily apply 24 V to the W2 terminal by adding a 12 V battery.
 - Check the BK1, BK2 and BK3 terminals respectively.

NOTICE

Do not apply more than 24 V. If more than 24 V is applied, the regulator/rectifier may be damaged. Do not apply 24 V more than a few seconds. If 24 V is applied for more than a few seconds, the regulator/rectifier may be damaged.

- ★ If the test light did not light when the 24 V was applied momentarily to the voltage monitoring terminal, the regulator/rectifier is defective. Replace it.
- ★ If the regulator/rectifier passes all of the tests described, it may still be defective. If the charging system still does not work properly after checking all of the components and the battery, test the regulator/rectifier by replacing it with a known good unit.

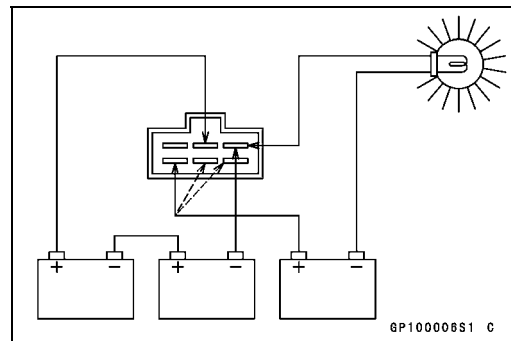

Charging System

Charging Voltage Inspection

- Check the battery condition (see Charging Condition Inspection).
- Warm up the engine to obtain actual alternator operating conditions.
- Check that the ignition switch is turned off, and connect the hand tester [A] to the battery terminals [B].

Special Tool - Hand Tester: 57001-1394

- Start the engine, and note the voltage readings at various engine speeds with the headlight turned on and then turned off (To turn off the headlight, disconnect the headlight connector on the headlight unit.). The readings should show nearly battery voltage when the engine speed is low, and, as the engine speed rises, the readings should also rise. But they must be kept under the specified voltage.

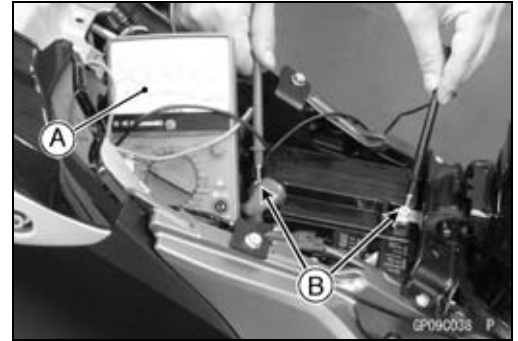

Charging Voltage

Tester Range	Connections		Reading
	Tester (+) to	Tester (-) to	
25 V DC	Battery (+)	Battery (-)	14.2 ~ 15.2 V

- Turn off the ignition switch to stop the engine, and disconnect the hand tester.
- ★ If the charging voltage is kept between the values given in the table, the charging system is considered to be working normally.
- ★ If the charging voltage is much higher than the values specified in the table, the regulator/rectifier is defective or the regulator/rectifier leads are loose or open.
- ★ If the charging voltage does not rise as the engine speed increases, then the regulator/rectifier is defective or the alternator output is insufficient for the loads. Check the alternator and regulator/rectifier to determine which part is defective.

16-40 ELECTRICAL SYSTEM

Charging System

Charging System Circuit

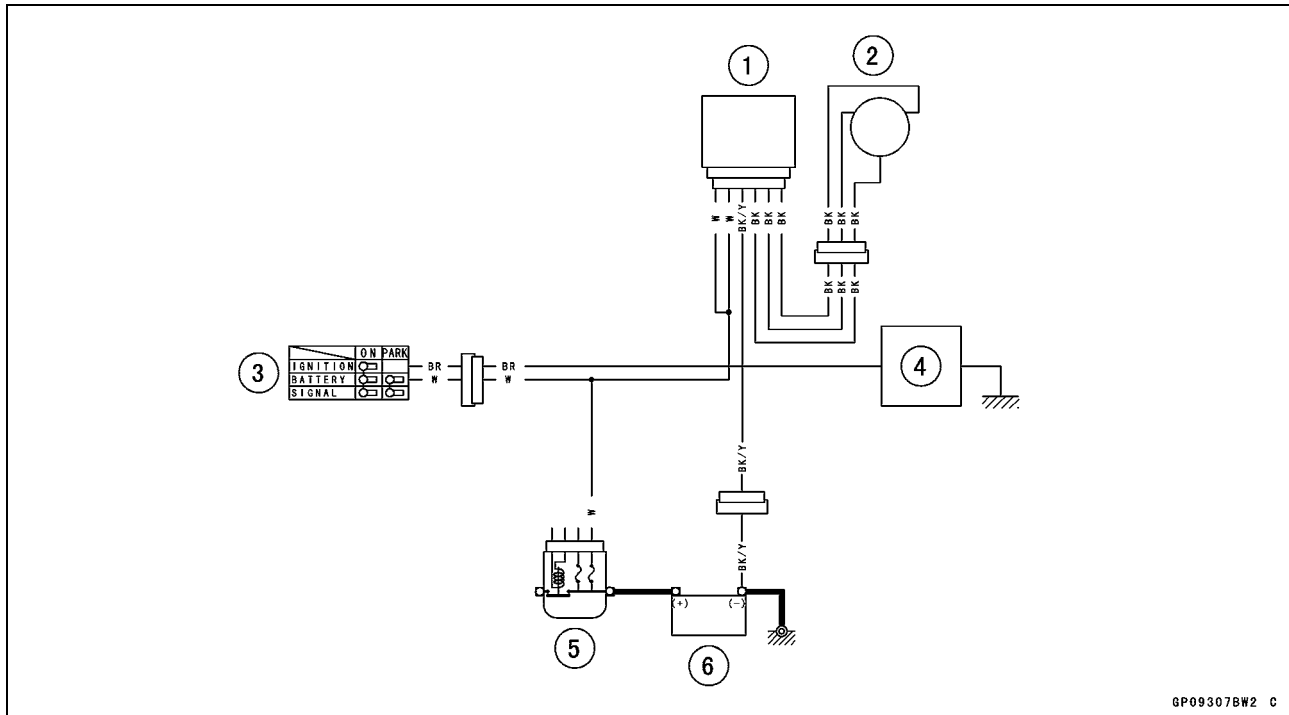

6P093078W2 C

1. Regulator/Rectifier
2. Alternator
3. Ignition Switch
4. Load
5. Main Fuse 30 A
6. Battery 12 V 8 Ah

Ignition System

⚠ WARNING

The ignition system produces extremely high voltage. Do not touch the spark plug, ignition coil or ignition coil lead while the engine is running, or you could receive a severe electrical shock.

NOTICE

Do not disconnect the battery cables or any other electrical connections when the ignition switch is ON, or while the engine is running. This is to prevent ECU damage.

Do not install the battery backwards. The negative side is grounded. This is to prevent damage to the ECU.

Crankshaft Sensor Removal

NOTICE

Never drop the sensor, especially on a hard surface. Such a shock to the sensor can damage it.

- Remove the right lower fairing (see Lower Fairing Removal in the Frame chapter).
- Support the fuel tank with a suitable bar (see Fuel Tank Removal in the Fuel System (DFI) chapter).
- Pull up the connector bracket [A].
- Remove the rear wheel rotation sensor connector [B] (ABS equipped models) and crankshaft sensor lead connector [C] from the bracket.
- Disconnect the crankshaft sensor lead connector.
- Clear the crankshaft sensor lead from the clamps [A].

- Remove:
 - Crankshaft Sensor Cover Bolts [A]
 - Crankshaft Sensor Cover [B]

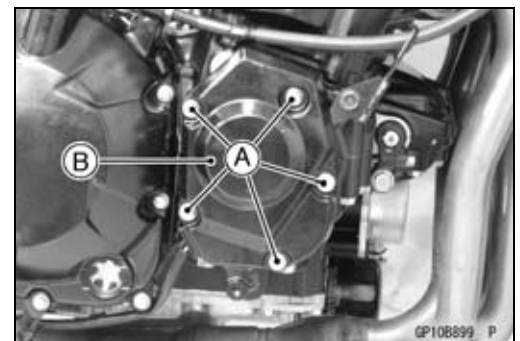
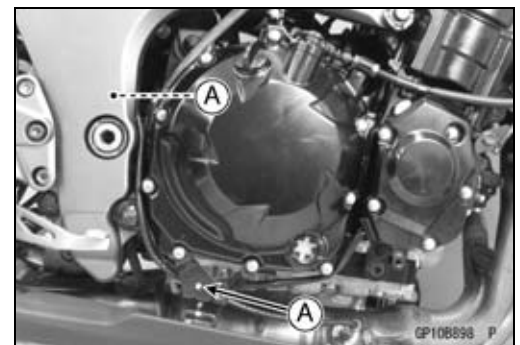
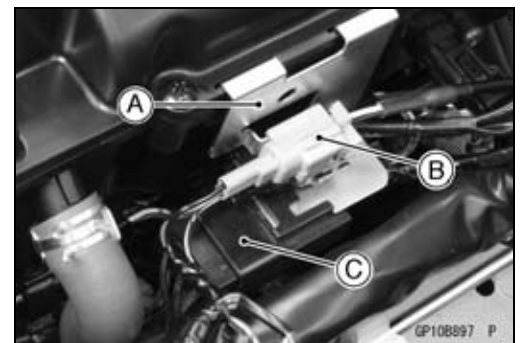

16-42 ELECTRICAL SYSTEM

Ignition System

- Remove:
 - Crankshaft Sensor Bolts [A]
 - Crankshaft Sensor [B]

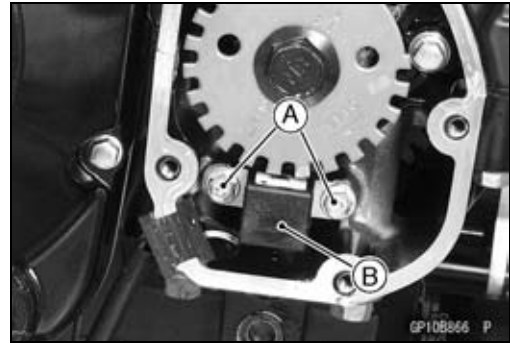

Crankshaft Sensor Installation

- Tighten:
 - Torque - Crankshaft Sensor Bolts: 5.9 N·m (0.60 kgf·m, 52 in·lb)**
- Apply silicone sealant [A] to the crankshaft sensor lead grommet and crankcase halves mating surface on the front and rear sides of the crankshaft sensor cover mount.
 - Sealant - Liquid Gasket, TB1211F: 92104-0004**

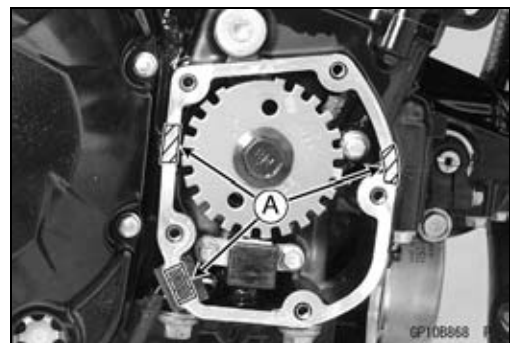

- Replace the O-ring [A] in the crankshaft sensor cover with a new one.

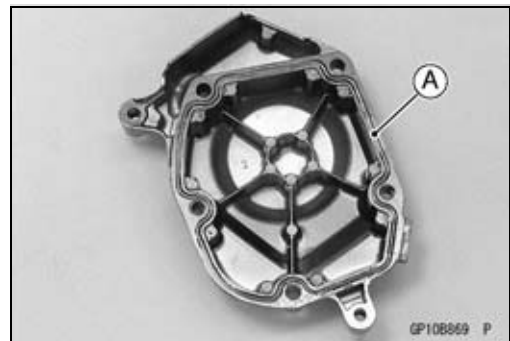

- Install:
 - Crankshaft Sensor Cover [A]
- Tighten:
 - Torque - Crankshaft Sensor Cover Bolts [B]: 12 N·m (1.2 kgf·m, 106 in·lb)**
- Run the crankshaft sensor lead correctly (see Cable, Wire, and Hose Routing section in the Appendix chapter).
- Confirm that the drain hose and clamp are installed securely and run the hose correctly (see Cable, Wire, and Hose Routing section in the Appendix chapter).

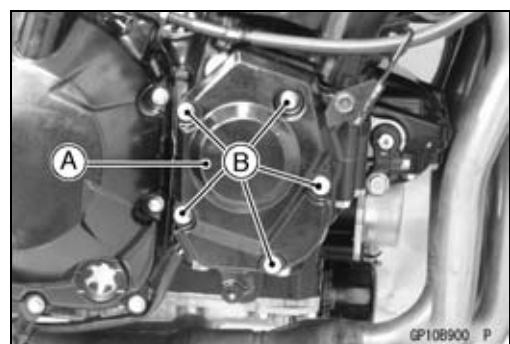

Ignition System

Crankshaft Sensor Inspection

- Remove:
 - Crankshaft Sensor Lead Connector [A] (see Crankshaft Sensor Removal)
- Set the hand tester [B] to the $\times 100 \Omega$ range and connect (+) lead to the yellow lead and (-) lead to the black lead in the connector.

Special Tools - Hand Tester: 57001-1394
Needle Adapter Set [C]: 57001-1457

Crankshaft Sensor Resistance: 376 ~ 564 Ω

- ★ If there is more resistance than the specified value, the coil has an open lead and must be replaced. Much less than this resistance means the coil is shorted, and must be replaced.
- Using the highest resistance range of the tester, measure the resistance between the crankshaft sensor leads and chassis ground.
- ★ Any tester reading less than infinity (∞) indicates a short, necessitating replacement of the crankshaft sensor assembly.

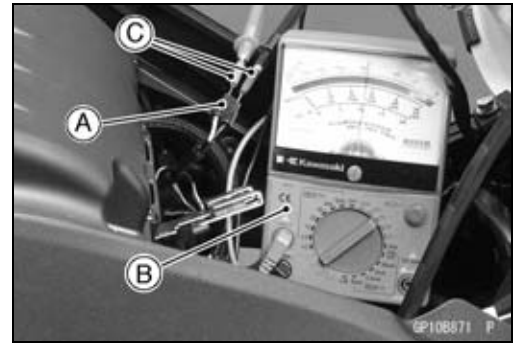

Crankshaft Sensor Peak Voltage Inspection

NOTE

○ Be sure the battery is fully charged.

- Remove:
 - Fuel Tank (see Fuel Tank Removal in the Fuel System (DFI) chapter)
 - Crankshaft Sensor Lead Connector [A] (see Crankshaft Sensor Removal)
- Set the hand tester [B] to the DC 10 V range.
- Connect the peak voltage adapter [C] to the hand tester and crankshaft sensor leads in the connector.

Special Tools - Hand Tester: 57001-1394
Peak Voltage Adapter: 57001-1415
Type: KEK-54-9-B
Needle Adapter Set [D]: 57001-1457

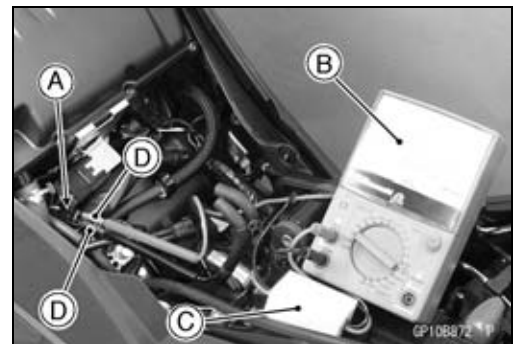

Connections:

Crankshaft Sensor Lead		Peak Voltage Adapter		Hand Tester
Yellow	←	Red	→	(+)
Black	←	Black	→	(-)

- Turn the ignition switch and engine stop switch ON.
- Pushing the starter button, turn the engine 4 ~ 5 seconds with the transmission gear in neutral to measure the crankshaft sensor peak voltage.
- Repeat the measurement 5 or more times.

Crankshaft Sensor Peak Voltage

Standard: 2.0 V or more

- ★ If the tester reading is not specified one, inspect the crankshaft sensor (see Crankshaft Sensor Inspection).

16-44 ELECTRICAL SYSTEM

Ignition System

Timing Rotor Removal

- Remove the crankshaft sensor (see Crankshaft Sensor Removal).
- Remove the timing rotor [A].
- Holding the timing rotor with the flywheel & pulley holder [B] and remove the rotor bolt [C].

Special Tool - Flywheel & Pulley Holder: 57001-1605

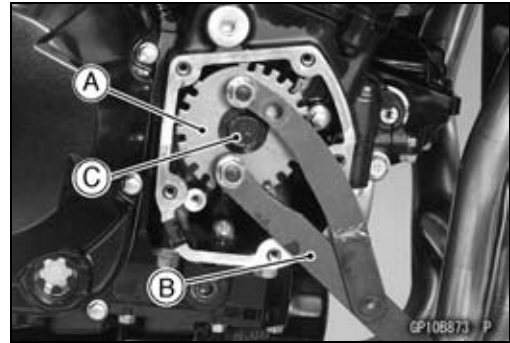

Timing Rotor Installation

- Install the timing rotor [A] with their teeth [B] aligned.
- Tighten:

Torque - Timing Rotor Bolt: 39 N·m (4.0 kgf·m, 29 ft·lb)

Special Tool - Flywheel & Pulley Holder: 57001-1605

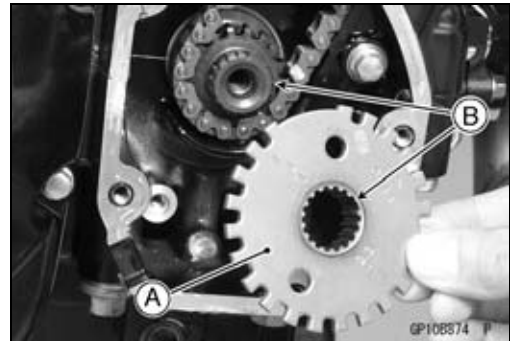

Stick Coil Removal

NOTICE

**Never drop the stick coils, especially on a hard surface.
Such a shock to the stick coils can damage it.**

- Remove:
 - Air Cleaner Housing (see Air Cleaner Housing Removal in the Fuel System (DFI) chapter)
- Disconnect the stick coil connectors [A].
- Pull the stick coils [B].

NOTICE

Do not pry the connector part of the coil while removing the coil.

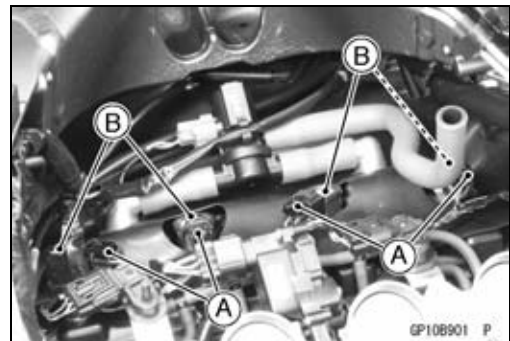

Stick Coil Installation

- Insert the coil as shown being careful of the coil heads [A] direction.
- Be sure the stick coils are installed by pulling up it lightly.
- Connect the connectors.

NOTICE

Do not tap the coil head while installing the coil.

- Run the hoses and harness correctly (see Cable, Wire, and Hose Routing section in the Appendix chapter).



Ignition System

Stick Coil Inspection

- Remove the stick coils (see Stick Coil Removal).
- Measure the primary winding resistance [A] as follows.
 - Connect the hand tester between the coil terminals.
 - Set the tester to the $\times 1 \Omega$ range, and read the tester.
- Measure the secondary winding resistance [B] as follows.
 - Connect the tester between the plug terminal and (-) coil terminal.
 - Set the tester to the $\times 1 \text{ k}\Omega$ range and read the tester.

Stick Coil Winding Resistance

Primary Windings: 1.1 ~ 1.5 Ω

Secondary Windings: 10.8 ~ 16.2 $\text{k}\Omega$

- ★ If the tester does not read as specified, replace the coil.

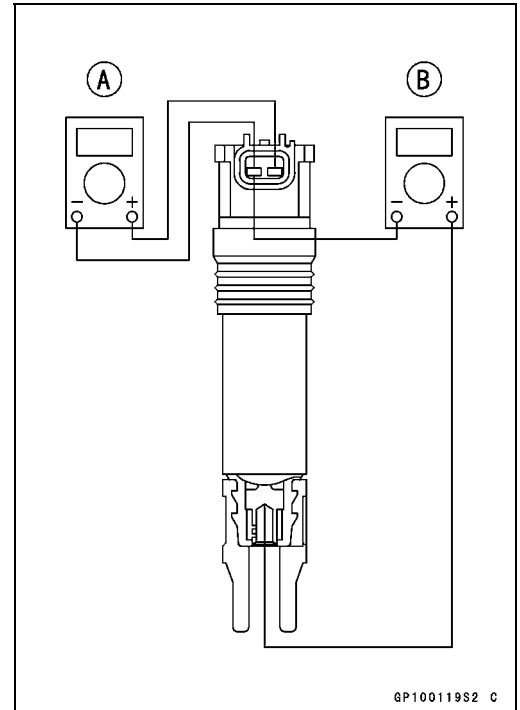

Stick Coil Primary Peak Voltage

NOTE

- Be sure the battery is fully charged.

- Remove the stick coils (see Stick Coil Removal), but do not remove the spark plugs.
- Measure the primary peak voltage as follows.
 - Install the new spark plug [A] into each stick coil [B], and ground them onto the engine.
 - Connect the peak voltage adapter [C] into the hand tester [D] which is set to the DC 250 V range.
 - Connect the adapter to the lead wire-peak voltage adapter [E] which is connected between the stick coil connector and stick coil.

ECU [F]

Battery [G]

Special Tools - Hand Tester: 57001-1394

Peak Voltage Adapter: 57001-1415

Type: KEK-54-9-B

Lead Wire-Peak Voltage Adapter: 57001-1449

Primary Lead Connection

Adapter (R, +) to lead wire-peak voltage adapter (W)

Adapter (BK, -) to lead wire-peak voltage adapter (R)

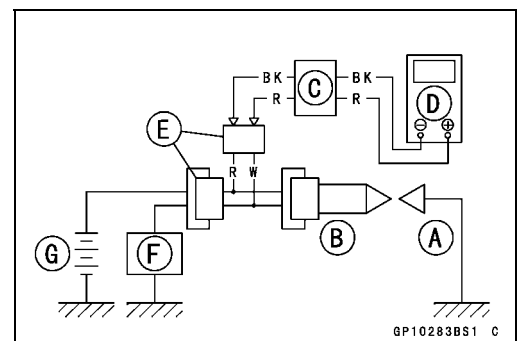
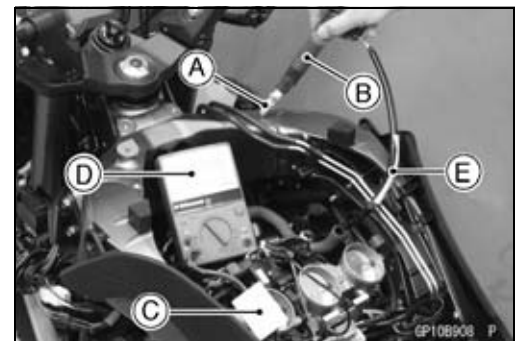

16-46 ELECTRICAL SYSTEM

Ignition System

⚠ WARNING

To avoid extremely high voltage shocks, do not touch the spark plugs or tester connections.

- Turn the ignition switch and the engine stop switch ON.
- Pushing the starter button, turn the engine 4 ~ 5 seconds with the transmission in neutral to measure the primary peak voltage.
- Repeat the measurements 5 times for one stick coil.

Stick Coil Primary Peak Voltage

Standard: 100 V or more

- Repeat the test for the other stick coil.
- ★ If the reading is less than the specified value, check the following.
 - Stick Coils (see Stick Coil Inspection)
 - Crankshaft Sensor (see Crankshaft Sensor Inspection)
 - ECU (see ECU Power Supply Inspection in the Fuel System (DFI) chapter)

Spark Plug Removal

- Refer to the Spark Plug Replacement in the Periodic Maintenance chapter.

Spark Plug Installation

- Refer to the Spark Plug Replacement in the Periodic Maintenance chapter.

Spark Plug Condition Inspection

- Remove the spark plugs (see Spark Plug Replacement).
- Visually inspect the spark plugs.
- ★ If the spark plug center electrode [A] and/or side electrode [B] are corroded or damaged, or if the insulator [C] is cracked, replace the plug.
- ★ If the spark plug is dirtied or the carbon is accumulated, replace the spark plug.
- Measure the gap [D] with a wire-type thickness gauge.
- ★ If the gap is incorrect, replace the spark plug.

Spark Plug Gap: 0.8 ~ 0.9 mm (0.031 ~ 0.035 in.)

- Use the standard spark plug or its equivalent.

Spark Plug: NGK CR9EIA-9

Interlock Operation Inspection

- Raise the rear wheel off the ground with stand.
- Turn the engine stop switch ON (run position).

1st Check

- Start the engine to the following conditions.

Condition:

Transmission Gear → 1st Position

Clutch Lever → Release

Sidestand → Down or Up

- Turn the ignition switch ON and push the starter button.
- Then the starter motor should not turn when the starter system circuit is normality.
- ★ If the engine is start, inspect the starter lockout switch, sidestand switch, neutral switch and relay box.

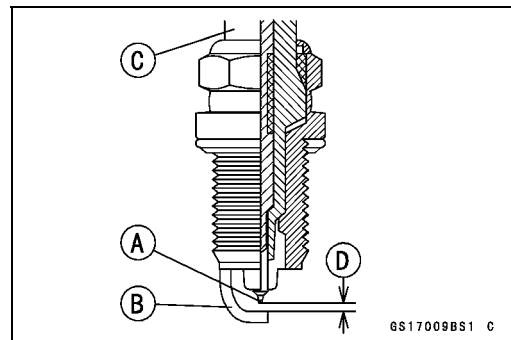

Ignition System

2nd Check

- Start the engine to the following conditions.

Condition:

Transmission Gear → 1st Position

Clutch Lever → Pulled in

Sidestand → Up

- Turn the ignition switch ON and push the starter button.
- Then the starter motor should turn when the starter system circuit is normality.
- ★ If the starter motor is not turn, inspect the starter lockout switch, sidestand switch, relay box, and starter relay.

3rd Check

- Inspect the engine for its secure stop after the following operations are completed.
- Run the engine to the following conditions.

Condition:

Transmission Gear → 1st Position

Clutch Lever → Pulled in

Sidestand → Up

- Set the sidestand on the ground, then the engine will stop.
- ★ If the engine does not stop, inspect the neutral switch, sidestand switch and relay box.
- ★ If their parts are normality, replace the ECU.

IC Igniter Inspection

- The IC igniter is built in the ECU [A].
- Refer to the following items.
 - Interlock Operation Inspection (see Interlock Operation Inspection)
 - Ignition System Troubleshooting (see Ignition System section)
 - ECU Power Supply Inspection (see ECU Power Supply Inspection in the Fuel System (DFI) chapter)



16-48 ELECTRICAL SYSTEM

Ignition System

Ignition System Troubleshooting

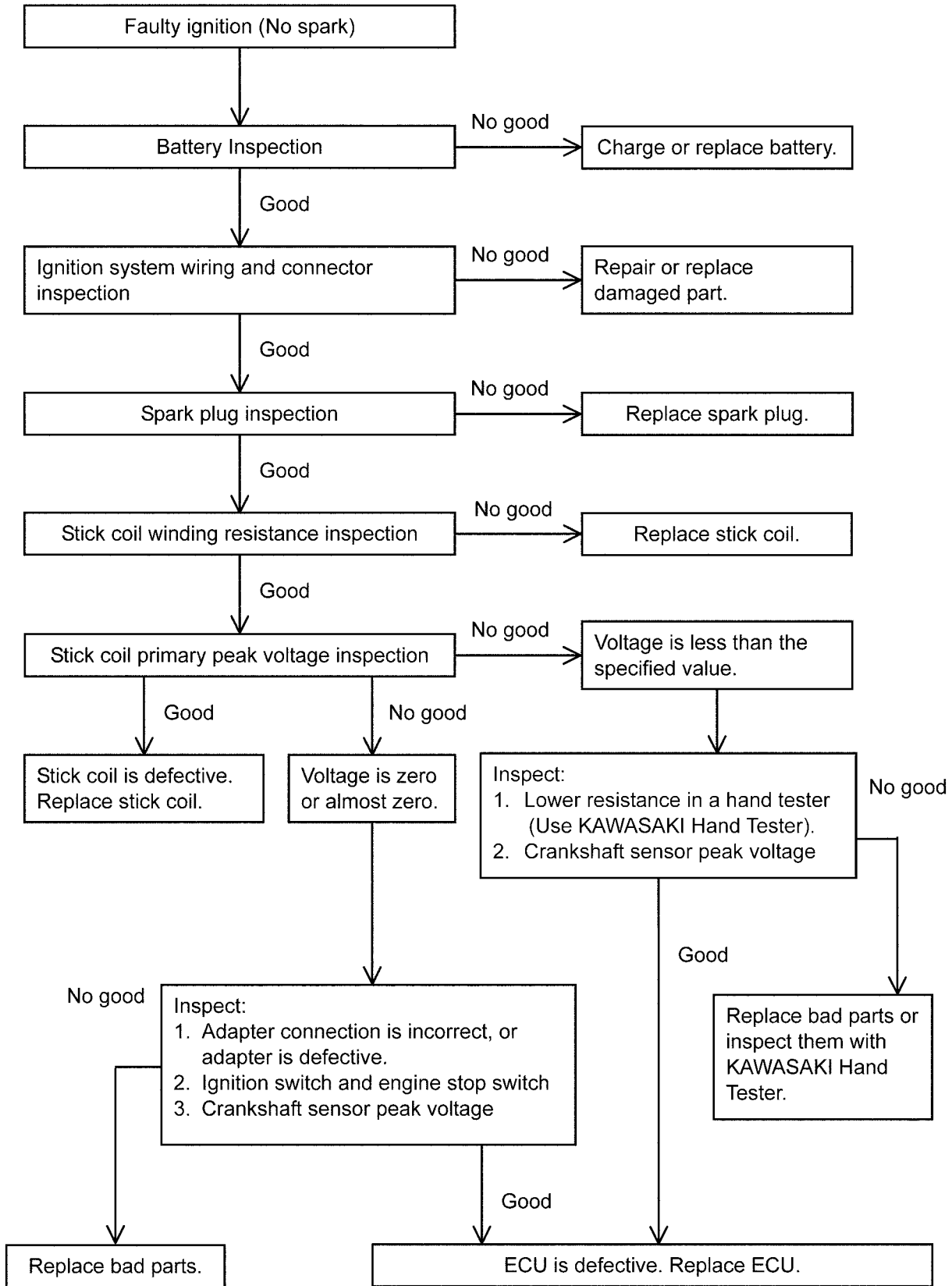

Ignition System

Ignition System Circuit

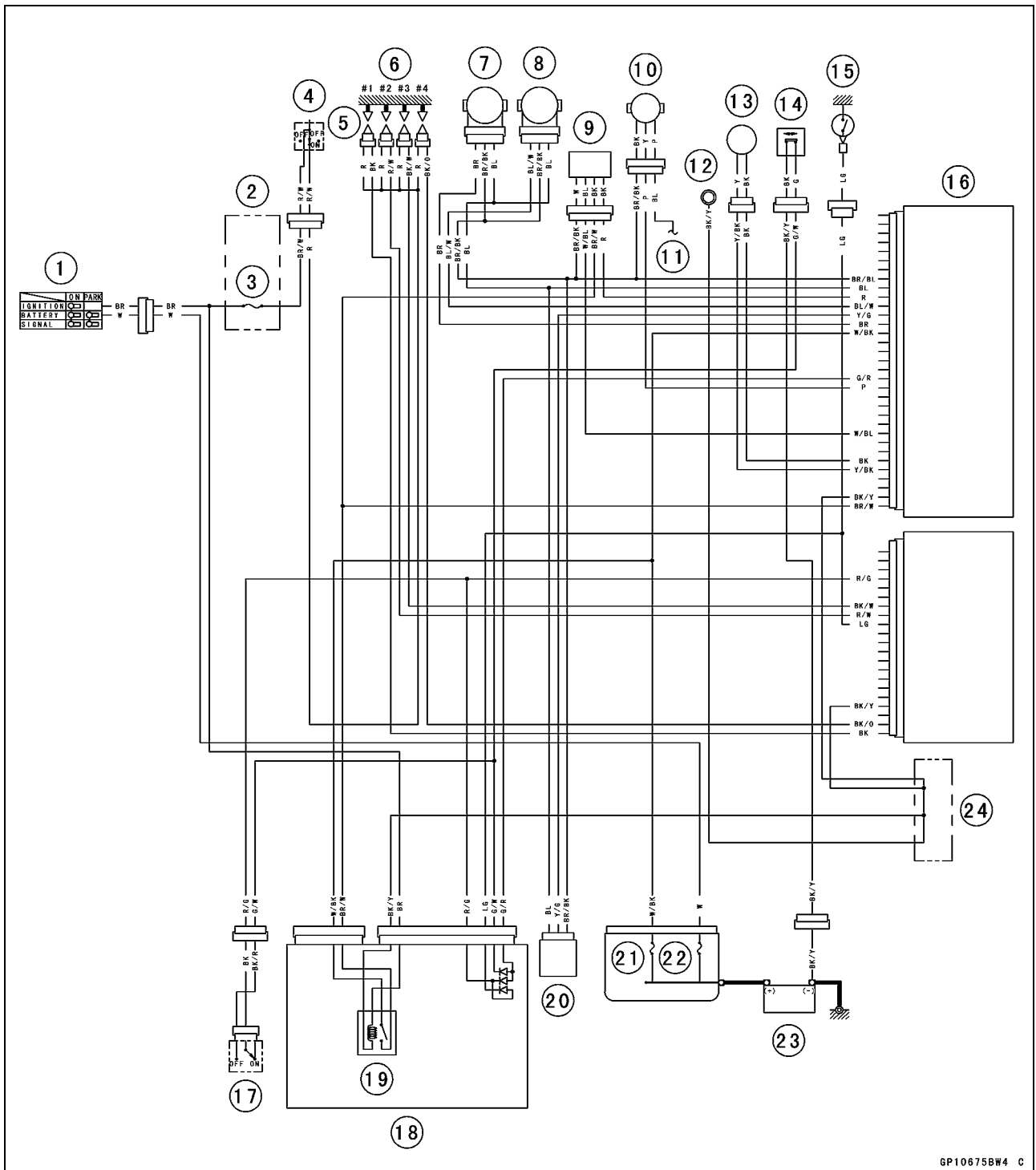

GP10675BW4 C

- | | |
|------------------------------------|----------------------------|
| 1. Ignition Switch | 13. Crankshaft Sensor |
| 2. Fuse Box 2 | 14. Sidestand Switch |
| 3. Ignition Fuse 15 A | 15. Neutral Switch |
| 4. Engine Stop Switch | 16. ECU |
| 5. Stick Coils | 17. Starter Lockout Switch |
| 6. Spark Plugs | 18. Relay Box |
| 7. Subthrottle Sensor | 19. ECU Main Relay |
| 8. Main Throttle Sensor | 20. Vehicle-down Sensor |
| 9. Oxygen Sensor (Equipped Models) | 21. FI Fuse 15 A |
| 10. Speed Sensor | 22. Main Fuse 30 A |
| 11. to Meter Unit | 23. Battery 12 V 8 Ah |
| 12. Frame Ground | 24. Water-proof Joint C |

16-50 ELECTRICAL SYSTEM

Electric Starter System

Starter Motor Removal

NOTICE

Do not tap the starter motor shaft or body. Tapping the shaft or body could damage the motor.

- Drain the coolant (see Coolant Change in the Periodic Maintenance chapter).
- Remove:
 - Left Lower Fairing (see Lower Fairing Removal in the Frame chapter)
 - Engine Sprocket Cover (see Engine Sprocket Cover Removal in the Final Drive chapter)
 - Harness Holder [A]
- Loosen the water hose clamp screw [B].
- Remove:
 - Water Hose [C]
 - Neutral Switch Connector [D]
 - Water Pipe Bolt [E]
 - Water Pipe [F]
- Remove the starter motor cable [A] from the cable holder [B].

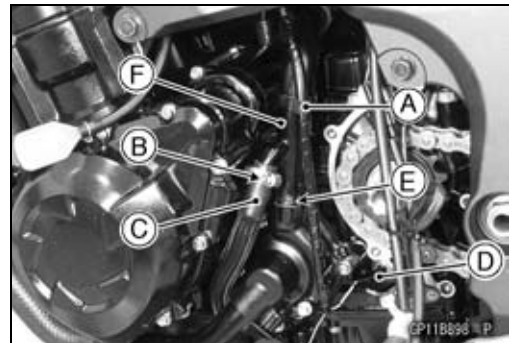

- Remove the mounting bolts [A].
- Pull out the starter motor [B] with the cable connected.

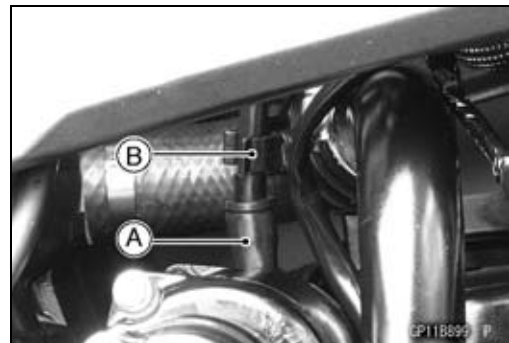

- Slide the rubber cap [A].
- Remove the starter motor cable terminal nut [B] and cable.

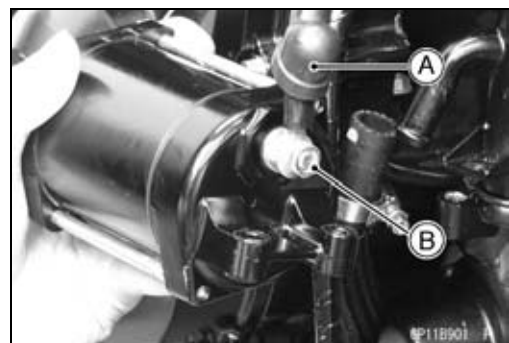
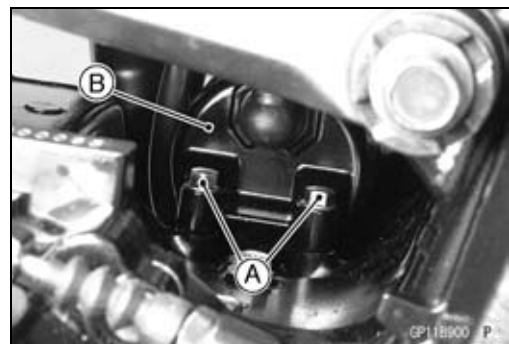

Electric Starter System

Starter Motor Installation

NOTICE

Do not tap the starter motor shaft or body. Tapping the shaft or body could damage the motor.

- When installing the starter motor, clean the starter motor legs [A] and crankcase [B] where the starter motor is grounded.

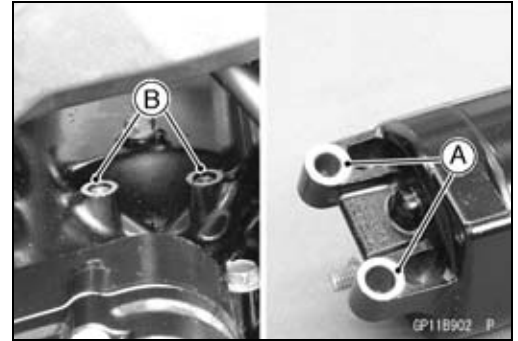

- Install the starter motor cable [A] as shown.
[B] Upward
- Tighten:
Torque - Starter Motor Cable Terminal Nut [C]: 5.9 N-m (0.60 kgf-m, 52 in-lb)
- Slide back the rubber cap to the original position.

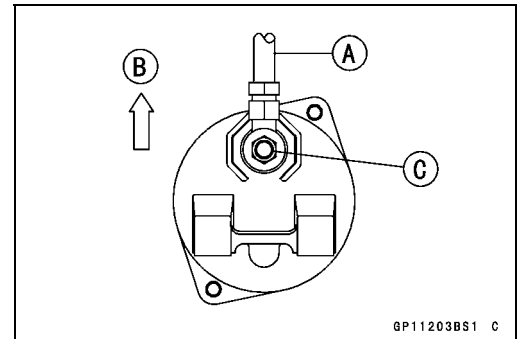

- Replace the O-ring [A] with a new one.
- Apply grease to the O-ring.
- Tighten:
Torque - Starter Motor Mounting Bolts: 9.8 N-m (1.0 kgf-m, 87 in-lb)
- Install the water hose and pipe (see Water Pump Installation in the Cooling System chapter).

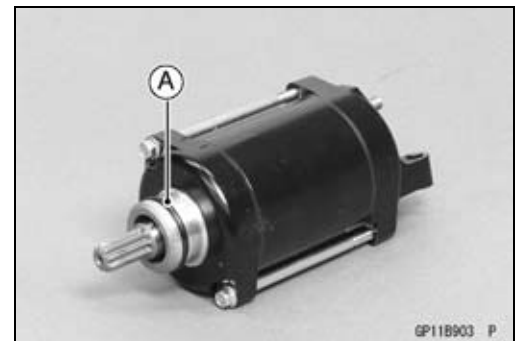

Starter Motor Disassembly

- Remove the starter motor (see Starter Motor Removal).
- Take off the starter motor through bolts [A] and remove the both end covers [B].

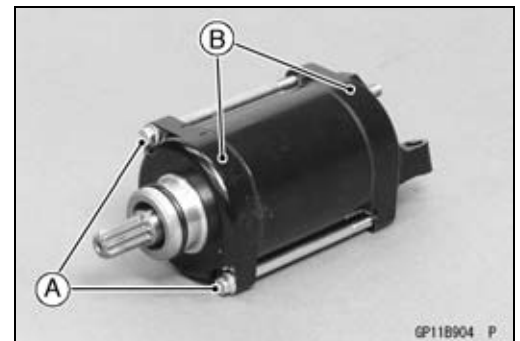

- Pull out the armature [A] out of the yoke [B].

NOTE

○ Do not remove the circlip [C] from the shaft.

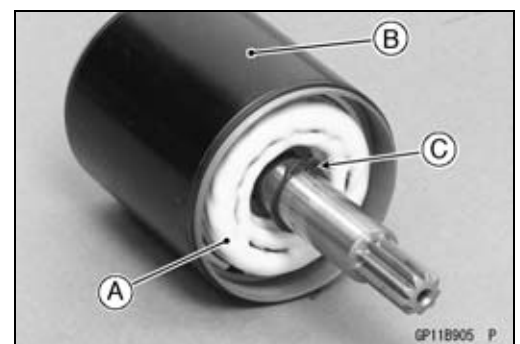

16-52 ELECTRICAL SYSTEM

Electric Starter System

- Remove the starter motor terminal locknut [A].



- Pull out the brushes from the brush holder [A].
- Remove:
 - Brush Springs [B]
 - Starter Motor Terminal [C]
 - Positive Brush Assy [D]
 - Screw [E]
 - Negative Brush Assy [F]
 - Brush Holder

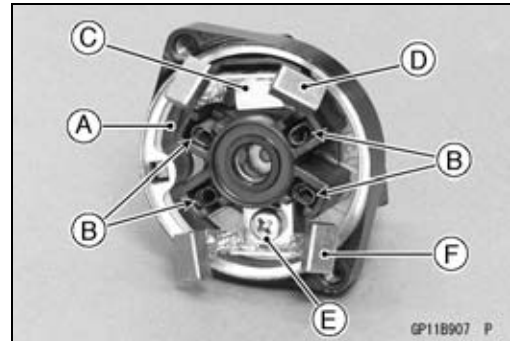

Starter Motor Assembly

- Align the hole [A] of the brush holder [B] to the boss [C] of the right-hand end cover [D].

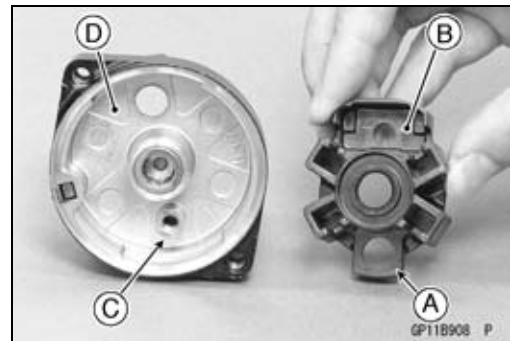

- Align the stoppers [A] of the negative brush assy [B] to the guides [C] of the brush holder [D].
- Tighten the screw securely.

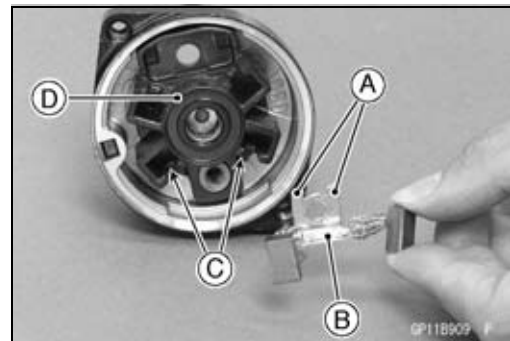

- Insert the jagged portion [A] on the starter motor terminal [B] to the slit [C] on the positive brush assy [D].
- Install the starter motor terminal to the brush holder.

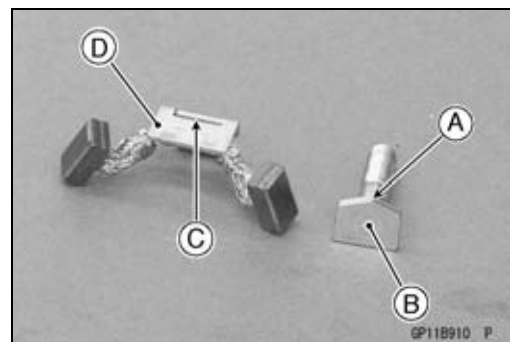

Electric Starter System

- Replace the O-ring [A] with a new one.
- Install the following parts to the starter motor terminal [B].
 - New O-ring
 - Collar [C]
 - Washer [D]
 - Starter Motor Terminal Locknut [E]
- Install the collar so that stepped side faces outward.
- Tighten:
 - Torque - Starter Motor Terminal Locknut: 11 N·m (1.1 kgf·m, 97 in·lb)**

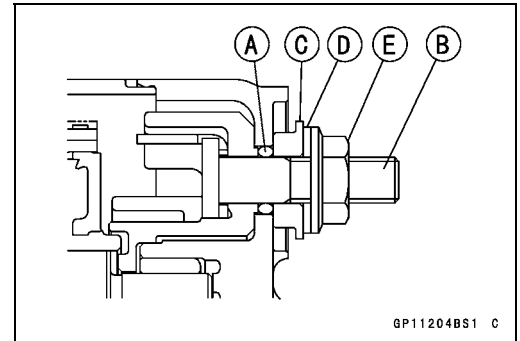

- Install the brush springs [A] and insert the brushes [B].

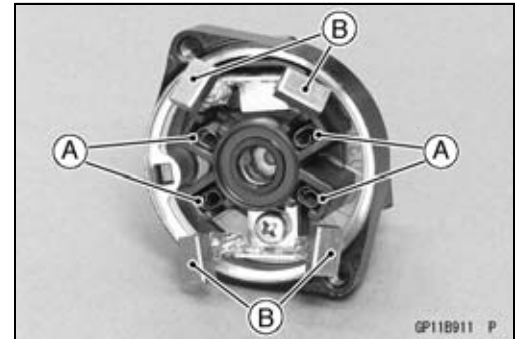

- Apply thin coat of grease to the oil seal [A].

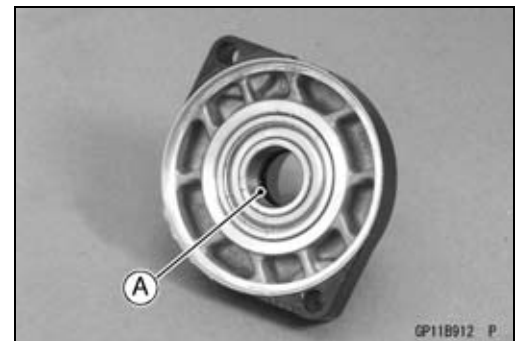

- Replace the O-rings [A] with new ones.
- Insert the armature [B] so that commutator side [C] faces hollow side [D] of the yoke [E].

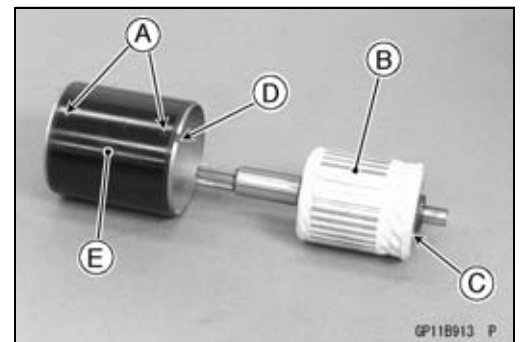

- Align the stopper [A] and hollow [B] to assemble the yoke and end cover.

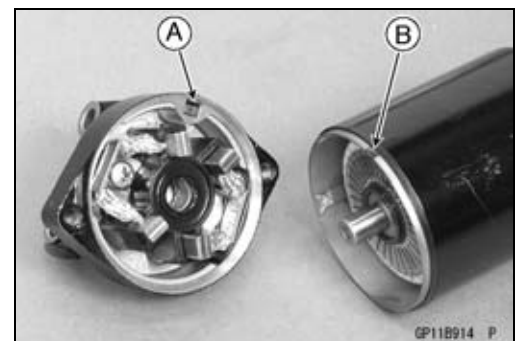

16-54 ELECTRICAL SYSTEM

Electric Starter System

- Align the marks [A] to assemble the yoke and the end cover [B].

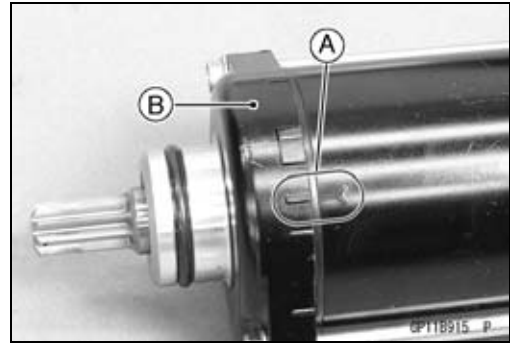

- Tighten:
Torque - Starter Motor Through Bolts [A]: 4.9 N·m (0.50 kgf·m, 43 in·lb)



Brush Inspection

- Measure the length of each brushes [A].
- ★ If any is worn down to the service limit, replace the brush assy.

Starter Motor Brush Length

- Standard: 12 mm (0.47 in.)
- Service Limit: 6.5 mm (0.26 in.)

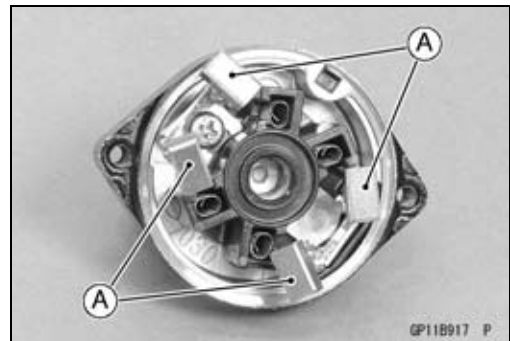

Commutator Cleaning and Inspection

- Clean the metallic debris off the between commutator segments [A].

NOTE

○ Do not use emery or sand paper on the commutator.

- Check the commutator for damage or abnormal wear.
- ★ Replace the starter motor with a new one if there is any damage or wear.
- Visually inspect the commutator segments for discoloration.
- ★ Replace the starter motor with a new one if discoloration is noticed.

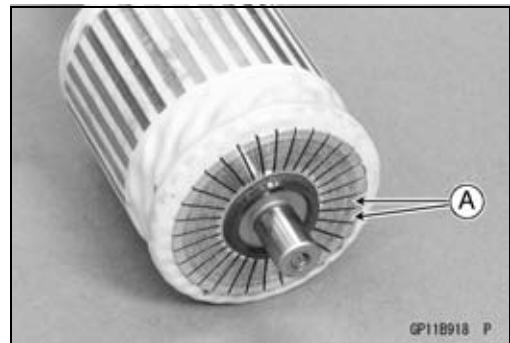

Electric Starter System

Armature Inspection

- Using the $\times 1 \Omega$ hand tester range, measure the resistance between any two commutator segments [A].

Special Tool - Hand Tester: 57001-1394

- ★ If there is a high resistance or no reading (∞) between any two segments, a winding is open and the starter motor must be replaced.
- Using the highest hand tester range, measure the resistance between the segments and the shaft [B].
- ★ If there is any reading at all, the armature has a short and the starter motor must be replaced.

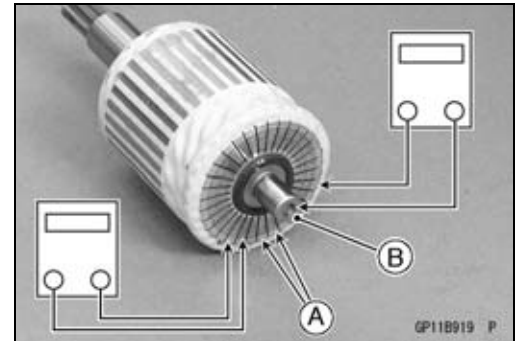

NOTE

○ Even if the foregoing checks show the armature to be good, it may be defective in some manner not readily detectable with the hand tester. If all other starter motor and starter motor circuit components check good, but the starter motor still does not turn over or only turns over weakly, replace the starter motor with a new one.

Brush Lead Inspection

- Using the $\times 1 \Omega$ hand tester range, measure the resistance as shown.

Right-hand End Cover and Negative Brushes [A]
Terminal Bolt and Positive Brushes [B]

Special Tool - Hand Tester: 57001-1394

- ★ If there is not close to zero ohms, the brush lead has an open. Replace the brush plate assy.

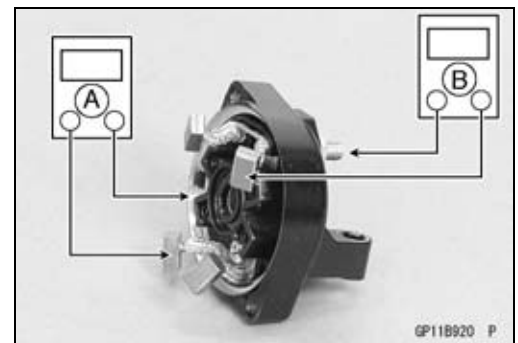

Right-hand End Cover Inspection

- Using the highest hand tester range, measure the resistance as shown.

Terminal Bolt and Right-hand End Cover [A]
Terminal Bolt and Negative Brushes [B]

Special Tool - Hand Tester: 57001-1394

- ★ If there is any reading, the brush assy and/or terminal bolt assy have a short. Replace the starter motor.

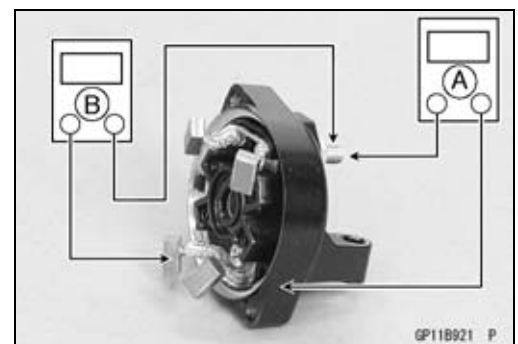

Starter Relay Inspection

- Remove:
Battery Negative (-) Cable (see Battery Removal)

16-56 ELECTRICAL SYSTEM

Electric Starter System

- Remove the cable terminal cover [A].

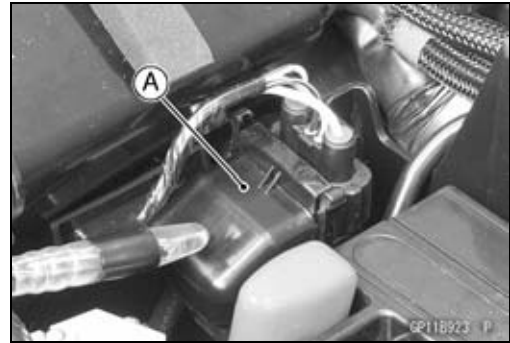

- Disconnect:
 - Connector [A]
 - Cable Terminals [B]
- Remove:
 - Starter Relay [C]

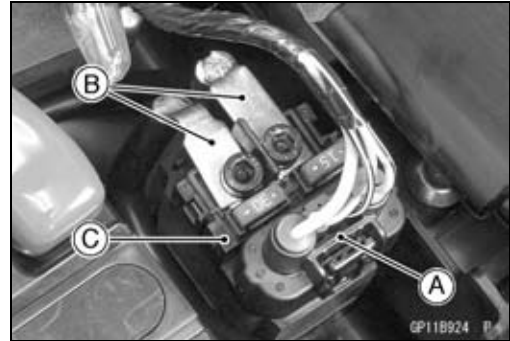

- Connect the hand tester [A] and 12 V battery [B] to the starter relay [C] as shown in the figure.

Special Tool - Hand Tester: 57001-1394

- ★ If the relay does not work as specified, the relay is defective. Replace the relay.

Testing Relay

Tester Range: × 1 Ω range

Criteria: When battery is connected → 0 Ω

When battery is disconnected → ∞ Ω

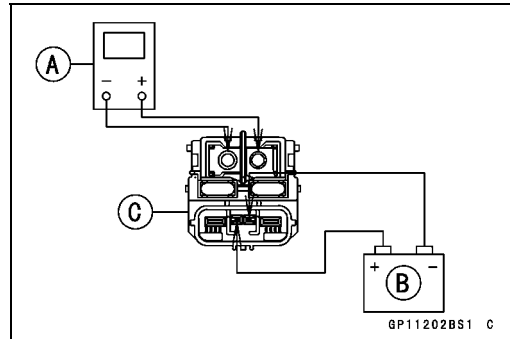

Electric Starter System

Electric Starter Circuit

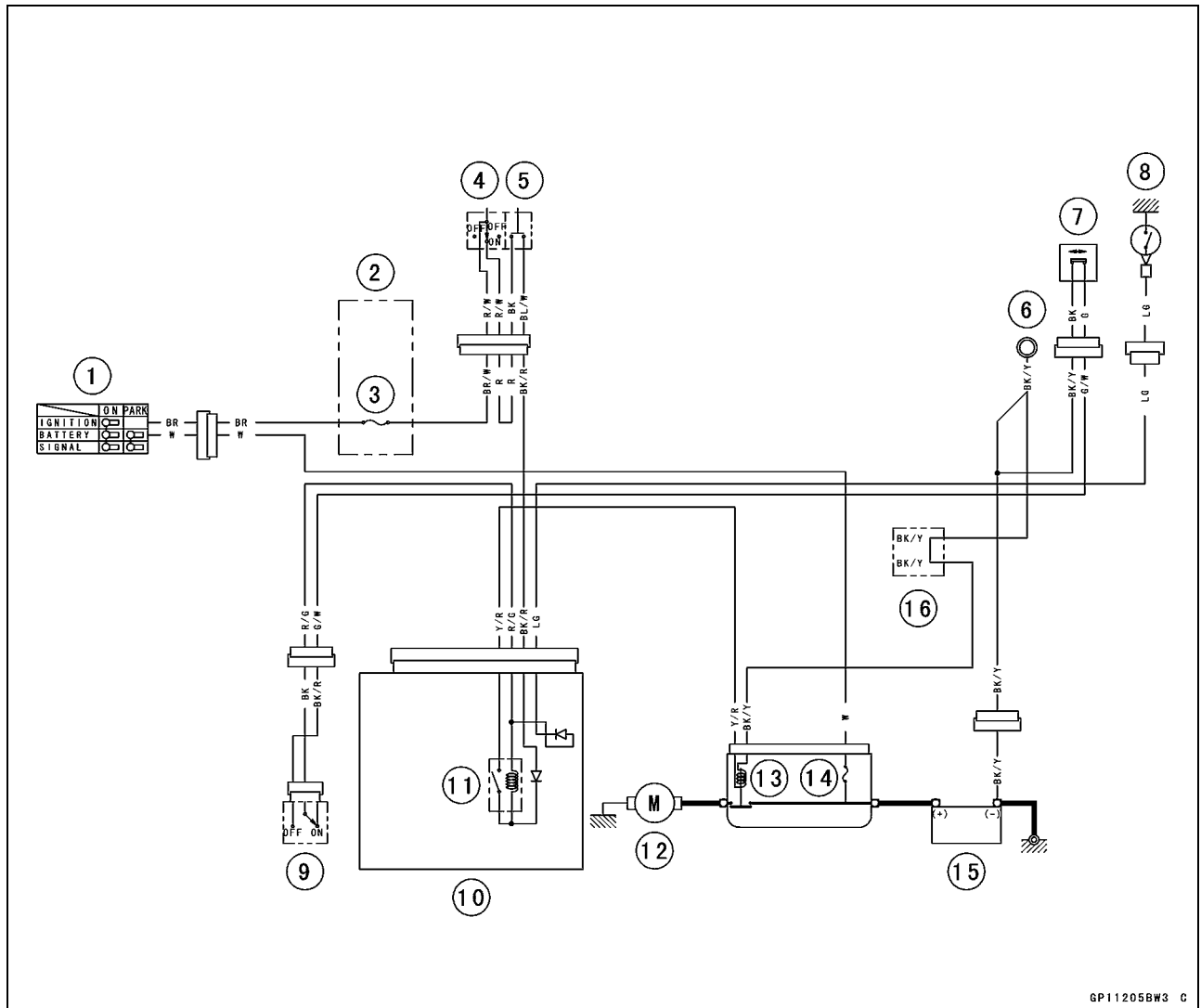

GP11205BW3 C

1. Ignition Switch
2. Fuse Box 2
3. Ignition Fuse 15 A
4. Engine Stop Switch
5. Starter Button
6. Frame Ground
7. Sidestand Switch
8. Neutral Switch
9. Starter Lockout Switch
10. Relay Box
11. Starter Circuit Relay
12. Starter Motor
13. Starter Relay
14. Main Fuse 30 A
15. Battery 12 V 8 Ah
16. Water-proof Joint B

16-58 ELECTRICAL SYSTEM

Lighting System

This motorcycle adopt the daylight system and have a headlight relay in the relay box. The headlight does not go on when the ignition switch and the engine stop switch are first turned on. The headlight comes on after the starter button is released and stays on until the ignition switch is turned off. The headlight will go out momentarily whenever the starter button is pressed and come back on when the button is released.

Headlight Beam Horizontal Adjustment

- Refer to the Headlight Aiming Inspection in the Periodic Maintenance chapter.

Headlight Beam Vertical Adjustment

- Refer to the Headlight Aiming Inspection in the Periodic Maintenance chapter.

Headlight Bulb Replacement

- Remove:
 - Meter Cover (see Upper Fairing Removal in the Frame chapter)
 - Headlight Lead Connector [A]
 - Headlight Bulb Dust Cover [B]

- Remove:
 - Hook [A]
 - Headlight Bulb [B]

- Replace the headlight bulb.

NOTICE

When handling the quartz-halogen bulb [A], never touch the glass portion with bare hands. Always use a clean cloth. Oil contamination from hands or dirty rags can reduce bulb life or cause the bulb to explode.

NOTE

- Clean off any contamination that inadvertently gets on the bulb with alcohol or soap and water solution.

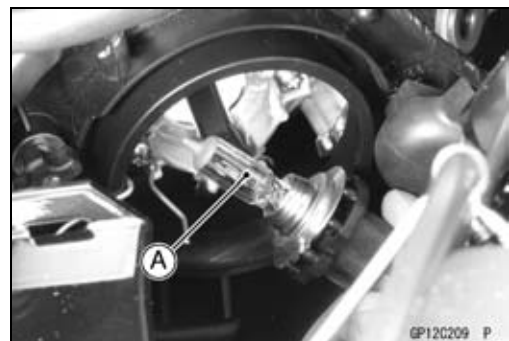
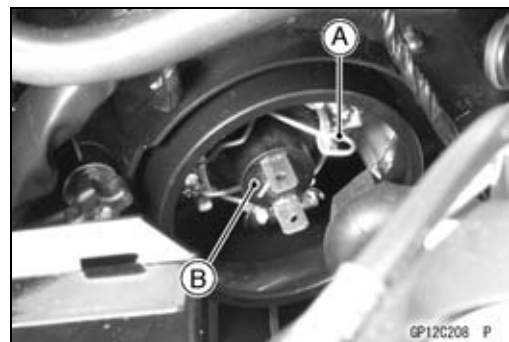
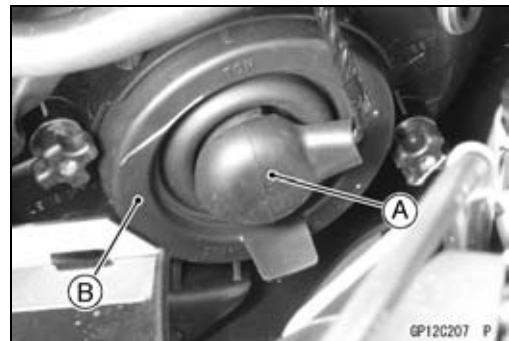

Lighting System

- Fit the projection [A] of the bulb in the hollow [B] of the headlight.

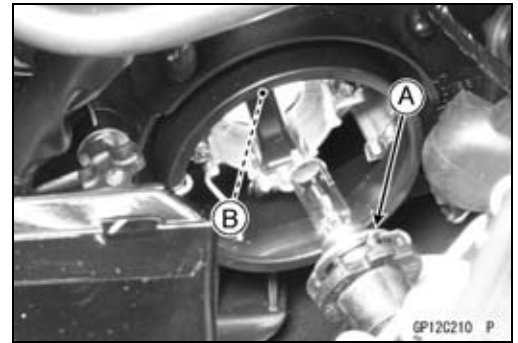

- Install the hook [A].

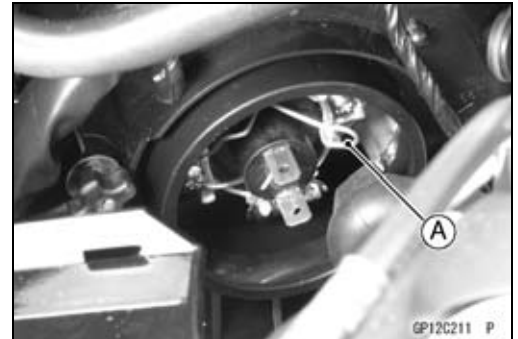

- Fit the dust cover [A] firmly onto the bulb so that the TOP mark [B] is aligned with the arrow mark [C] on the headlight.

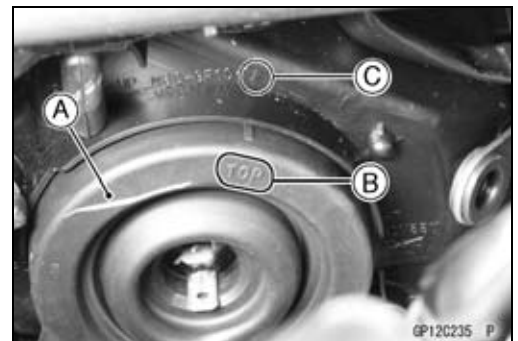

- Be sure to fit the dust cover [A] onto the bulb [B] firmly as shown in the figure.
 - Good [C]
 - Bad [D]
- After installation, adjust the headlight aim (see Headlight Aiming Inspection in the Periodic Maintenance chapter).

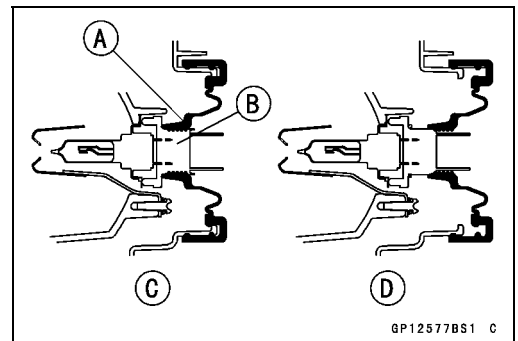

Headlight Removal/Installation

- Remove:
 - Upper Fairing (see Upper Fairing Removal in the Frame chapter)
 - Bolts [A]
 - Clamp [B]
 - Headlight Assy [C]
- Installation is the reverse of removal.

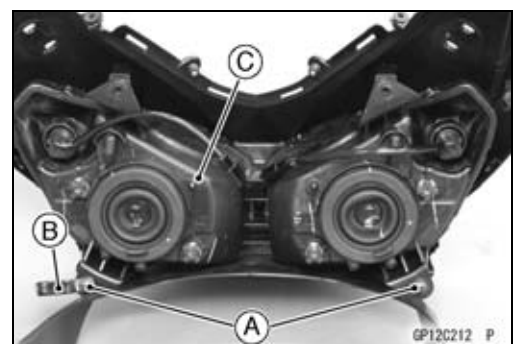

16-60 ELECTRICAL SYSTEM

Lighting System

City Light Bulb Replacement

- Remove:
 - Meter Cover (see Upper Fairing Removal in the Frame chapter)
- Pull out the socket [A] and remove it with the bulb.

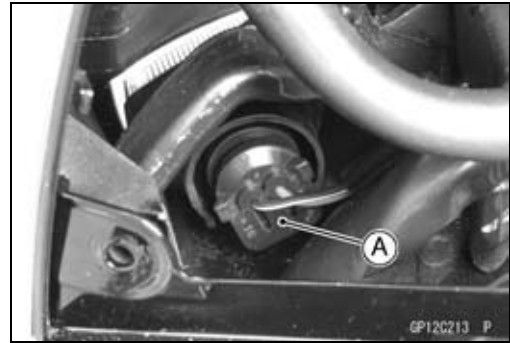

- Pull out the bulb [A] straight from the socket.

NOTICE

Do not turn the bulb. Pull the bulb out to prevent damage to the bulb. Do not use bulb rated for greater wattage than the specified value.

- Replace the bulb with a new one.
- Install the socket securely.

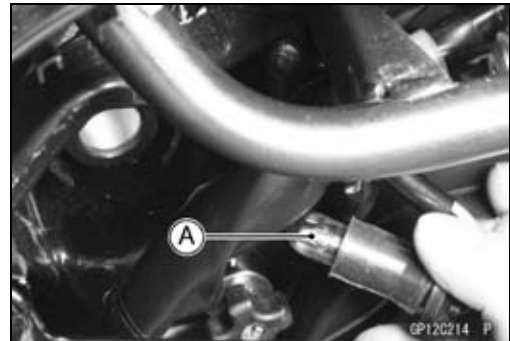

Tail/Brake Light (LED) Removal

- Remove:
 - Seat Cover (see Seat Cover Removal in the Frame chapter)
 - Tail/Brake Light Mounting Bolts [A]

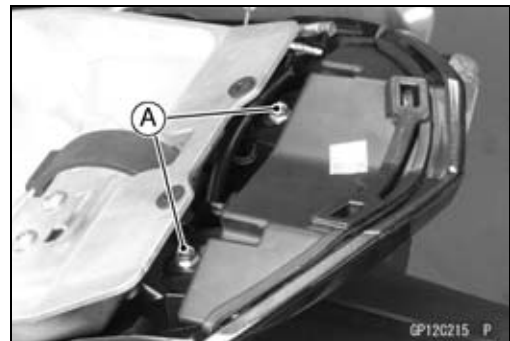

- Disconnect the tail/brake light lead connector [A] to remove the tail/brake light (LED).

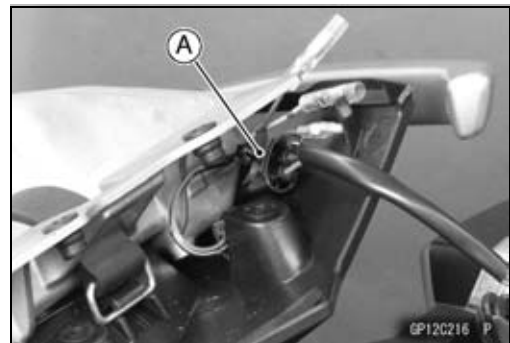

Tail/Brake Light (LED) Installation

- Installation is the reverse of removal.
- Tighten the tail/brake light mounting bolts securely.

Lighting System

License Plate Light Bulb Replacement

- Remove:
 - Screws [A]
 - License Plate Light Cover [B] and Lens
- Pull out the bulb [A].
- Replace the bulb with a new one.
- Insert the new bulb into the socket.
- Fit the projections [A] on the lens to the cover grooves [B].
- Tighten the license plate light cover screws.

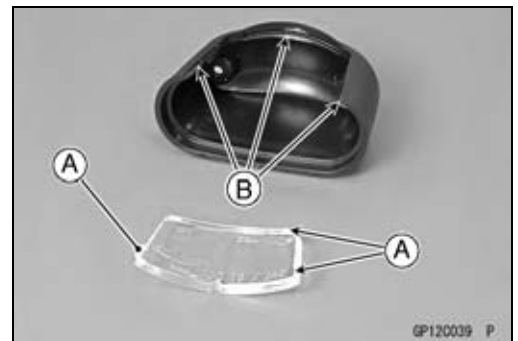
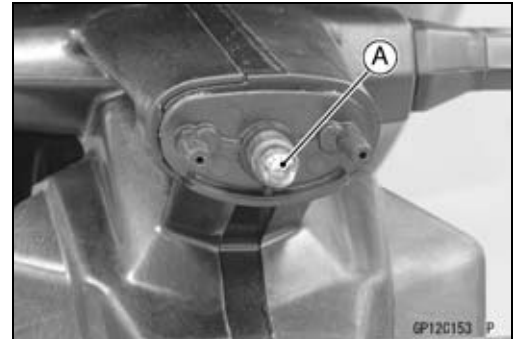
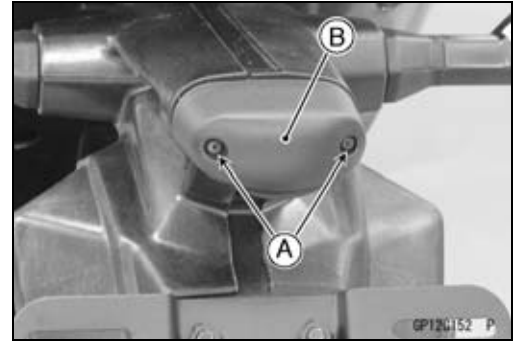

16-62 ELECTRICAL SYSTEM

Lighting System

Headlight/Tail Light Circuit

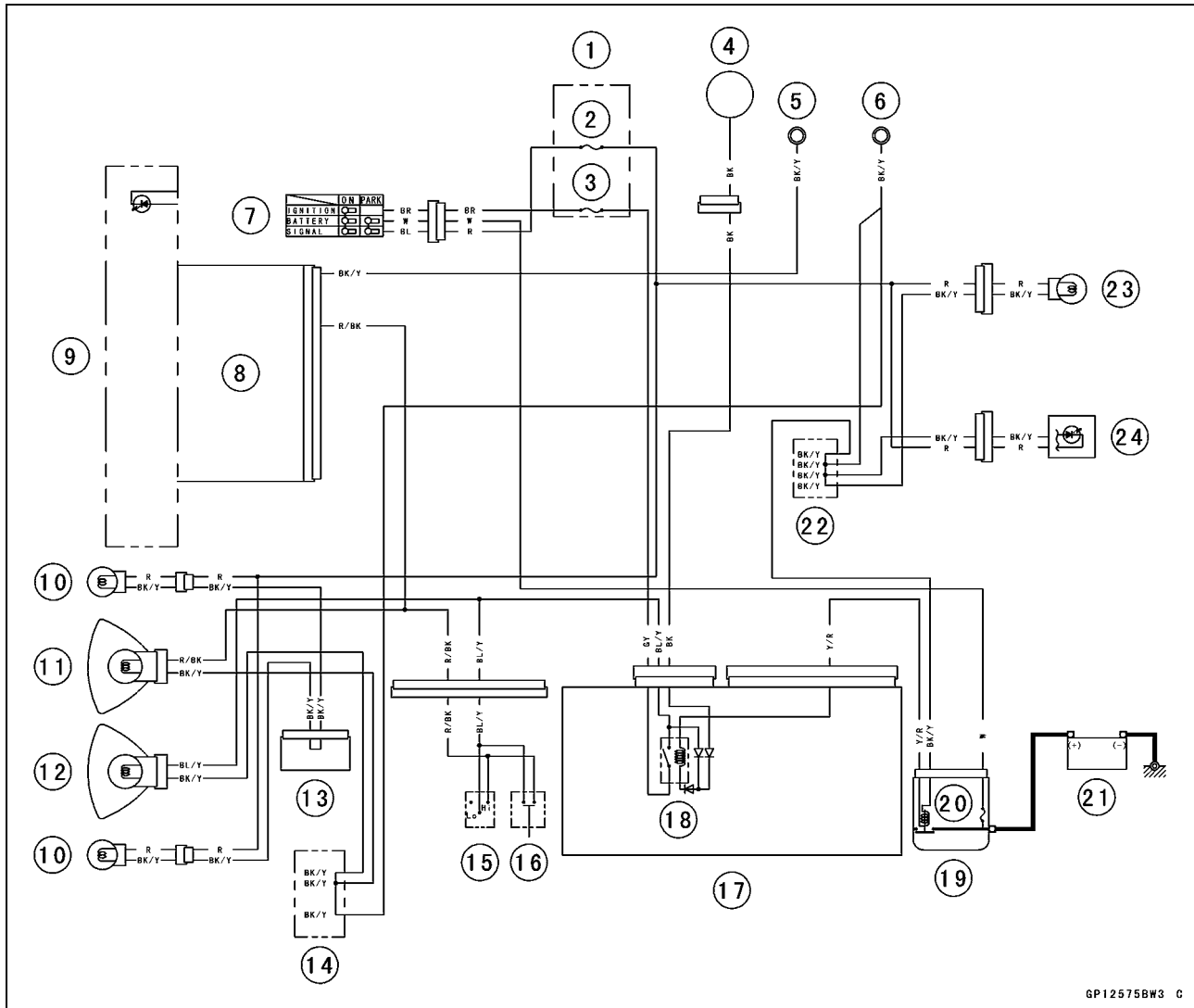

GP12575BW3 C

- | | |
|------------------------------------|---|
| 1. Fuse Box 2 | 13. Joint Connector |
| 2. Turn Signal Relay Fuse 10 A | 14. Water-proof Joint A |
| 3. Headlight Fuse 10 A | 15. Dimmer Switch |
| 4. Alternator | 16. Passing Button (Other than US, CA and CAL Models) |
| 5. Meter Ground | 17. Relay Box |
| 6. Frame Ground | 18. Headlight Circuit Relay |
| 7. Ignition Switch | 19. Starter Relay |
| 8. Meter Unit | 20. Main Fuse 30 A |
| 9. High Beam Indicator Light (LED) | 21. Battery 12 V 8 Ah |
| 10. City Light 12 V 5 W | 22. Water-proof Joint B |
| 11. Headlight (High) 12 V 55 W | 23. License Plate Light 12 V 5 W |
| 12. Headlight (Low) 12 V 55 W | 24. Tail/Brake Light (LED) |

Lighting System

Turn Signal Light Bulb Replacement Front Turn Signal Light

- Remove:
 - Lower Fairing (see Lower Fairing Removal in the Frame chapter)
 - Inner Fairings (see Inner Fairing Removal in the Frame chapter)
- Turn the socket [A] counterclockwise and pull out the socket together with the bulb.



- Push and turn the bulb [A] counterclockwise and remove it.

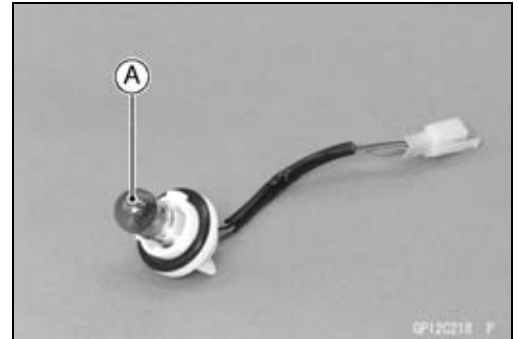

- Insert the new bulb [A] by aligning its upper and lower pins [B] with the upper and lower grooves [C] in the socket, and turn the bulb clockwise.
- Turn the bulb about 15°.

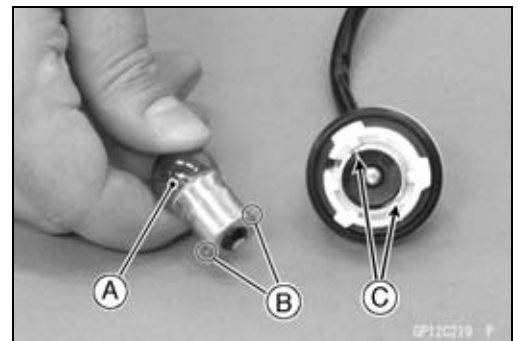

- Pushing the socket and turn it clockwise.
- Fit the projections [A] of the socket into the grooves [B] of the turn signal light.
- Install the removed parts (see appropriate chapters).

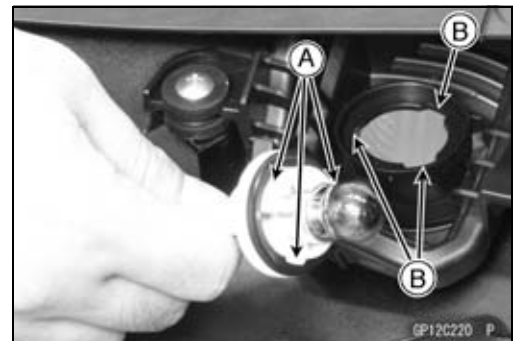

Rear Turn Signal Light

- Unscrew the screw [A] and remove the lens.



16-64 ELECTRICAL SYSTEM

Lighting System

- Push and turn the bulb [A] counterclockwise and remove it.



- Insert the new bulb [A] by aligning its upper and lower pins [B] with the upper and lower grooves [C] in the socket, and turn the bulb clockwise.
- Turn the bulb about 15°.

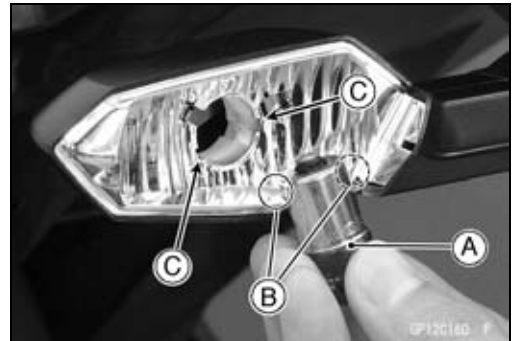

- Fit the projection [A] on the lens to the groove [B] on the socket.
- Tighten the screw.

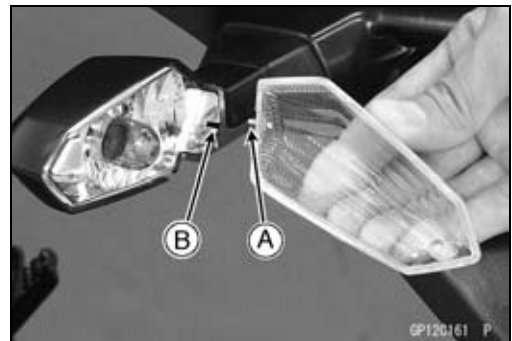

Turn Signal Relay Inspection

- Remove:
 - Left Lower Fairing (see Lower Fairing Removal in the Frame chapter)
- Pull up the turn signal relay [A].
- Disconnect the turn signal relay connector [B].

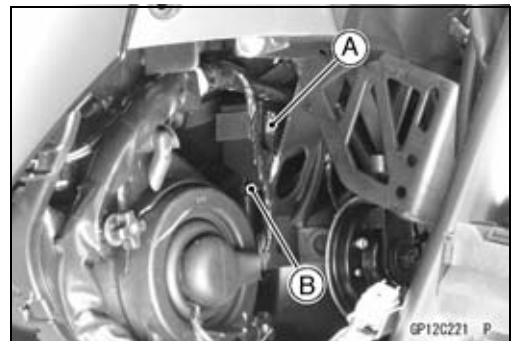

Lighting System

- Connect one 12 V battery and turn signal lights as indicated in the figure, and count how many times the lights flash for one minute.

Turn Signal Relay [A]

Turn Signal Lights [B]

12 V Battery [C]

- ★ If the lights do not flash as specified, replace the turn signal relay.

Testing Turn Signal Relay

Load		Flashing Times (c/m*)
The Number of Turn Signal Lights	Wattage (W)	
1**	10	140-250
2	20	75-95

*: Cycle(s) per minute

** : Correspond to "one light burned out"

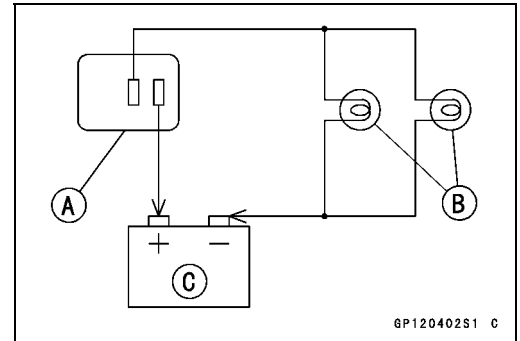

6P120402S1 C

16-66 ELECTRICAL SYSTEM

Lighting System

Turn Signal Light Circuit

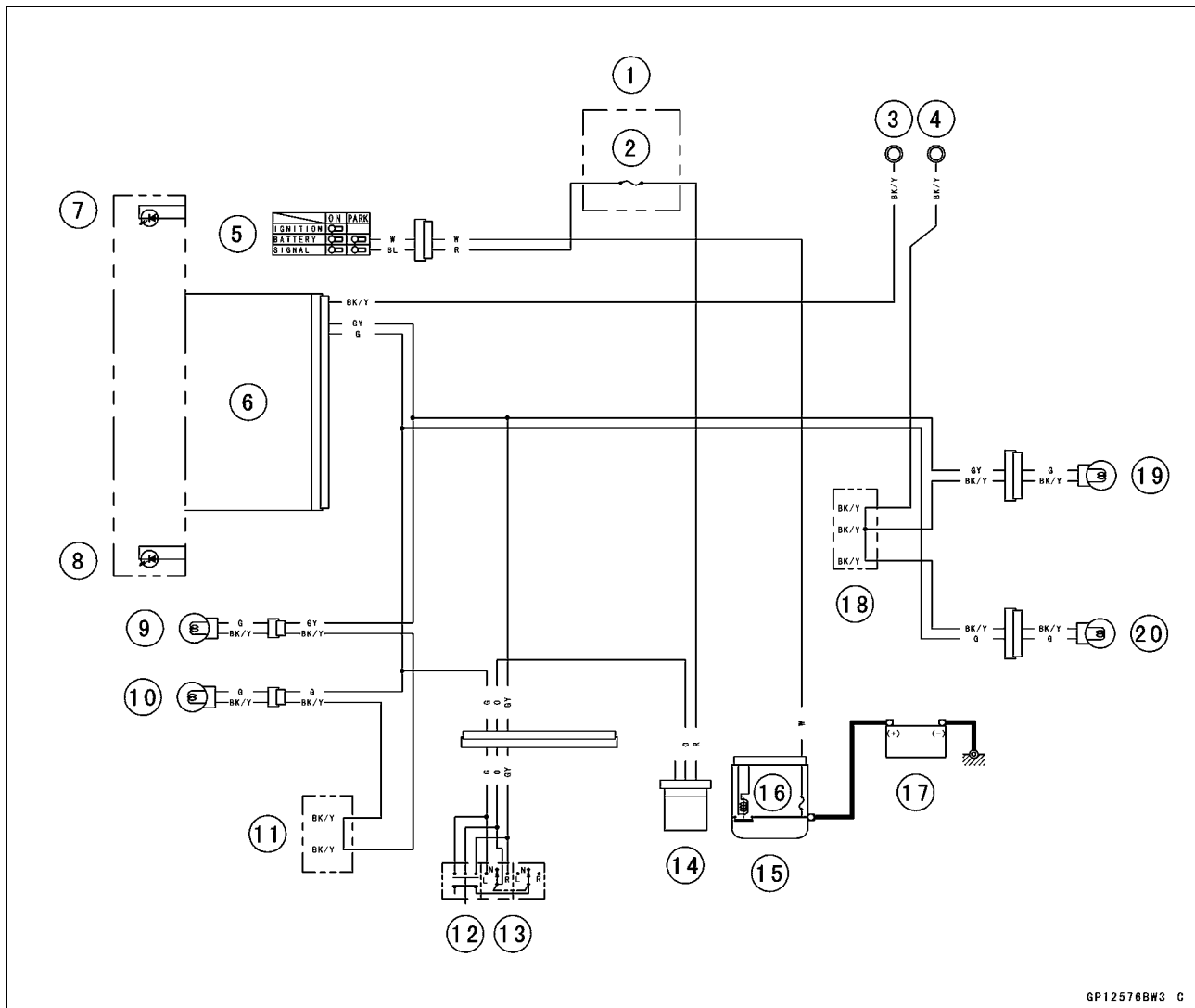

GP12576BW3 C

1. Fuse Box 2
2. Turn Signal Relay Fuse 10 A
3. Meter Ground
4. Frame Ground
5. Ignition Switch
6. Meter Unit
7. Right Turn Signal Indicator Light (LED)
8. Left Turn Signal Indicator Light (LED)
9. Front Right Turn Signal Light 12 V 21 W
10. Front Left Turn Signal Light 12 V 21 W
11. Water-proof Joint A
12. Hazzard Switch
13. Turn Signal Switch
14. Turn Signal Relay
15. Starter Relay
16. Main Fuse 30 A
17. Battery 12 V 8 Ah
18. Water-proof Joint B
19. Rear Right Turn Signal Light 12 V 10 W
20. Rear Left Turn Signal Light 12 V 10 W

Air Switching Valve

Air Switching Valve Operation Test

- Refer to the Air Suction System Damage Inspection in the Periodic Maintenance chapter.

Air Switching Valve Unit Test

- Remove the air switching valve (see Air Switching Valve Removal in the Engine Top End chapter).
- Set the hand tester [A] to the $\times 1 \Omega$ range and connect it to the air switching valve terminals as shown in the figure.

Special Tool - Hand Tester: 57001-1394

Air Switching Valve Resistance

Standard: 18 ~ 22 Ω at 20°C (68°F)

- ★ If the tester does not read as specified value, replace it with a new one.
- Connect the 12 V battery [A] to the air switching valve terminals as shown in the figure.

- Blow the air to the intake air duct [A], and make sure does not flow the blown air from the outlet air duct [B].

- Disconnect the 12 V battery.
- Blow the air to the intake air duct [A] again, and make sure flow the blown air from the outlet air duct [B].
- ★ If the air switching valve does not operate as described, replace it with a new one.

NOTE

- To check air flow through the air switching valve, just blow through the air switching valve hose (intake side) [C].

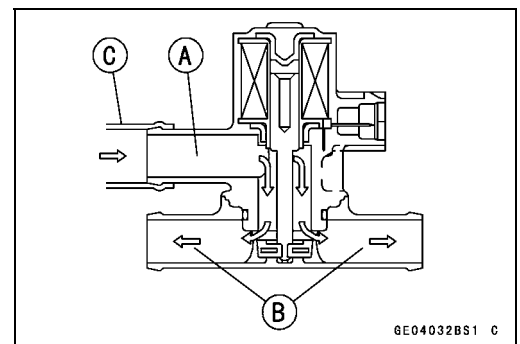
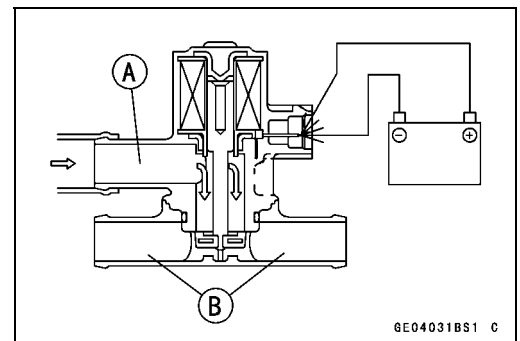
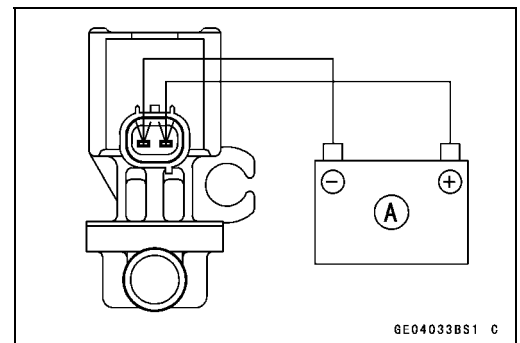
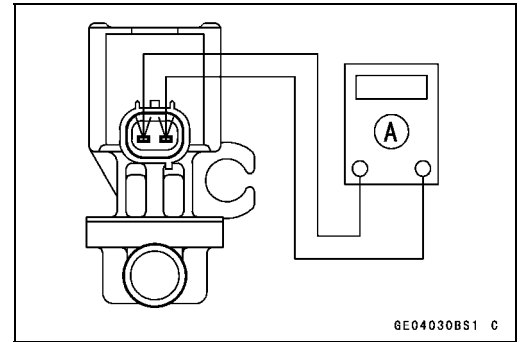

16-68 ELECTRICAL SYSTEM

Air Switching Valve

Air Switching Valve Circuit

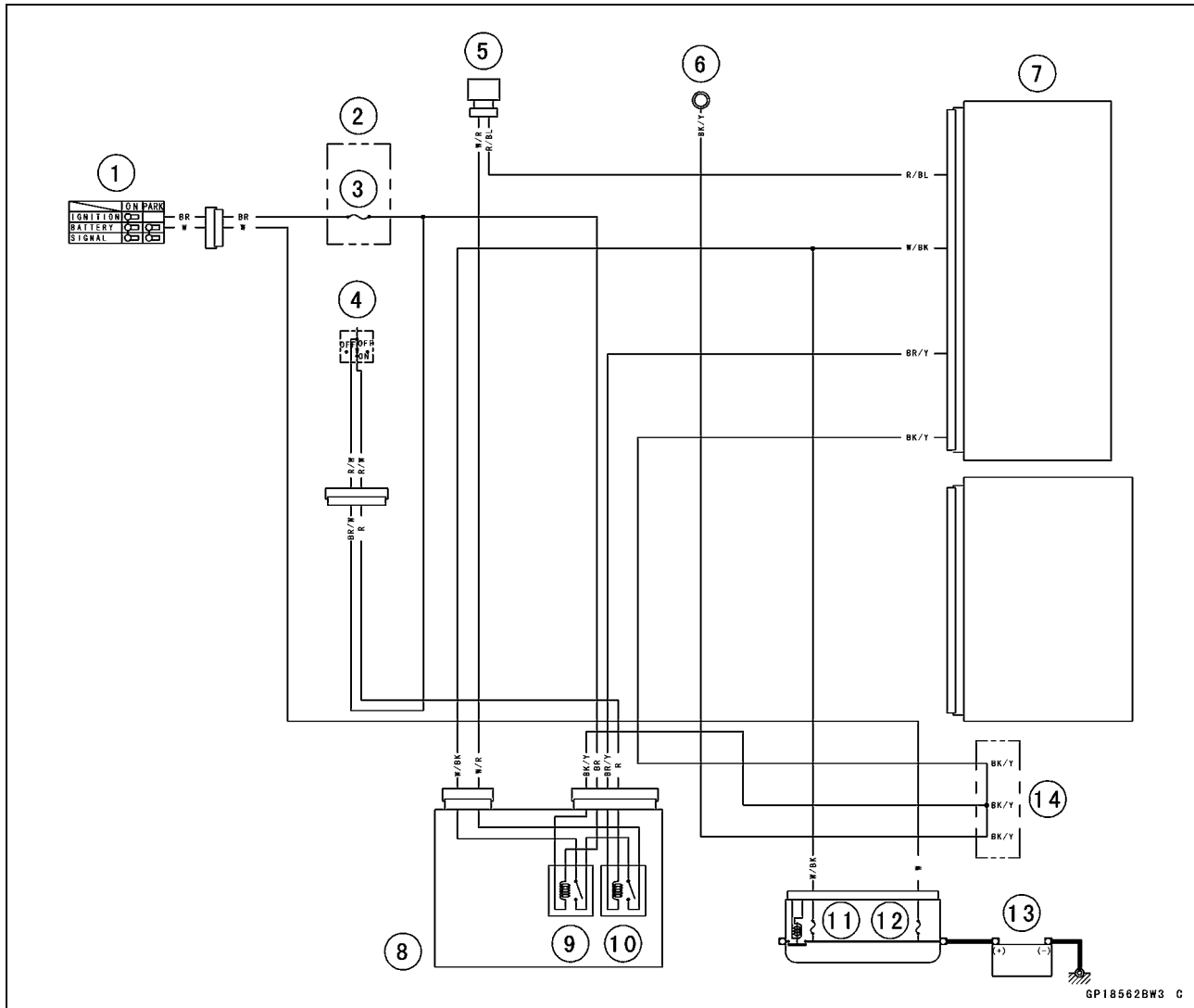

GP18562BW3 C

1. Ignition Switch
2. Fuse Box 2
3. Ignition Fuse 15 A
4. Engine Stop Switch
5. Air Switching Valve
6. Frame Ground
7. ECU
8. Relay Box
9. ECU Main Relay
10. Fuel Pump Relay
11. FI Fuse 15 A
12. Main Fuse 30 A
13. Battery 12 V 8 Ah
14. Water-proof Joint C

Radiator Fan System

Fan Motor Inspection

- Remove the left lower fairing (see lower Fairing Removal in the Frame chapter).
- Remove the rubber band [A].

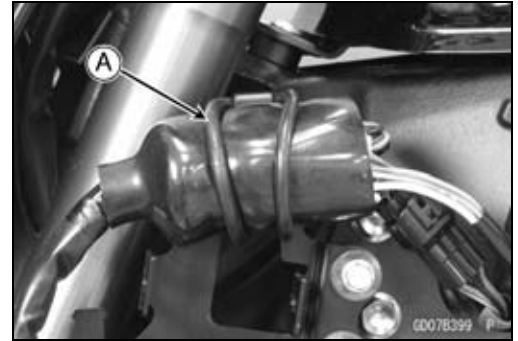

- Slide the dust cover [A].
- Disconnect the connector [B].
- Using an auxiliary leads, supply battery power to the fan motor.
- ★ If the fan does not rotate, the fan motor is defective and must be replaced.

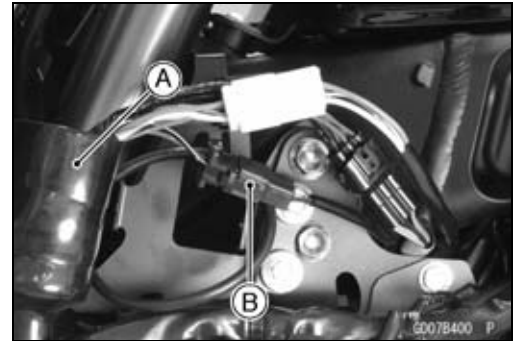

16-70 ELECTRICAL SYSTEM

Radiator Fan System

Radiator Fan Circuit

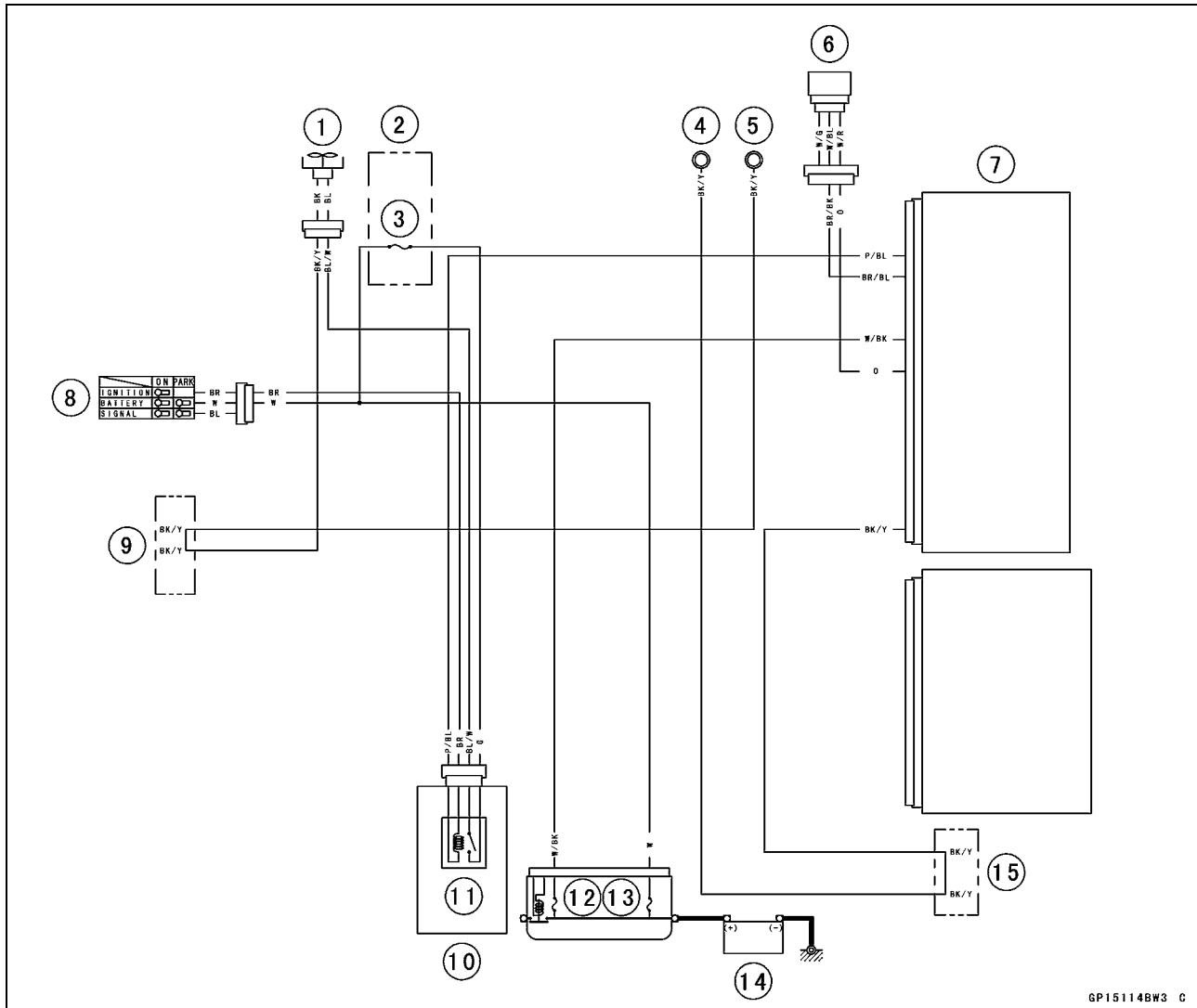

GP15114BW3 C

1. Radiator Fan Motor
2. Fuse Box 2
3. Fan Fuse 15 A
4. Meter Ground
5. Frame Ground
6. Water Temperature Sensor
7. ECU
8. Ignition Switch
9. Water-proof Joint A
10. Relay Box
11. Radiator Fan Relay
12. FI Fuse 15 A
13. Main Fuse 30 A
14. Battery 12 V 8 Ah
15. Water-proof Joint C

Meter, Gauge, Indicator Unit

Meter Unit Removal/Installation

- Remove:
 - Windshield Bracket Cover (see Upper Fairing Removal in the Frame chapter)
- Slide the dust cover [A] and disconnect the connector.
- Pull the meter unit [B] forward to remove it from the bracket [C].

NOTICE

Place the meter unit so that the face is up. If a meter unit is left upside down or sideways for any length of time, it will malfunction.

- Installation is the reverse of removal.

Meter Unit Disassembly

- Remove:
 - Meter Unit (see Meter Unit Removal/Installation)
 - Screws [A]
 - Lower Meter Cover [B]

- Separate the meter assembly [A] and upper meter cover [B].

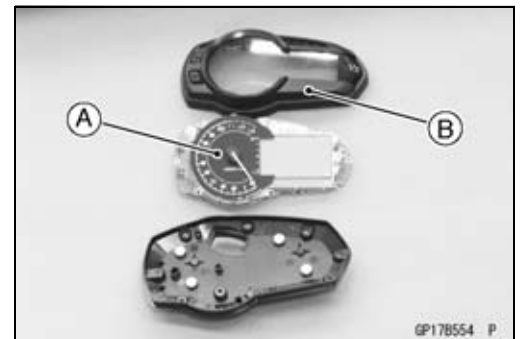
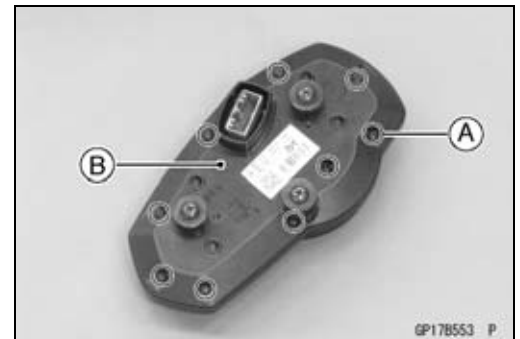
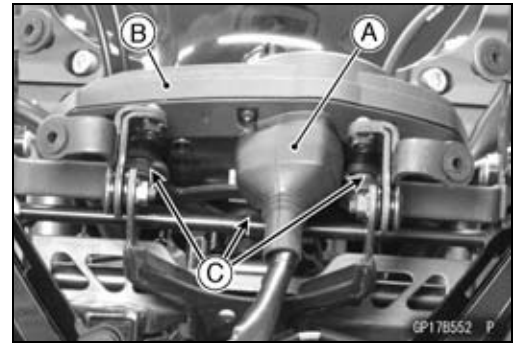

16-72 ELECTRICAL SYSTEM

Meter, Gauge, Indicator Unit

Electronic Combination Meter Unit Inspection

- Remove the meter unit [A].
 - [1] Neutral Indicator Light (LED) Ground (-)
 - [2] Right Turn Signal indicator Light (LED) (+)
 - [3] High Beam Indicator Light (LED) (+)
 - [4] Water Temperature Sensor
 - [5] Unused
 - [6] Unused
 - [7] Unused
 - [8] Unused
 - [9] Unused
 - [10] Left Turn Signal indicator Light (LED) (+)
 - [11] Warning Indicator Light (LED) (-)
 - [12] Tachometer Pulse
 - [13] Speed Sensor Pulse
 - [14] ECU Communication Pulse
 - [15] Fuel Level Sensor
 - [16] Ignition
 - [17] Battery (+)
 - [18] Unused
 - [19] Ground (-)
 - [20] ABS Indicator Light (LED) (-) (Equipped Models)

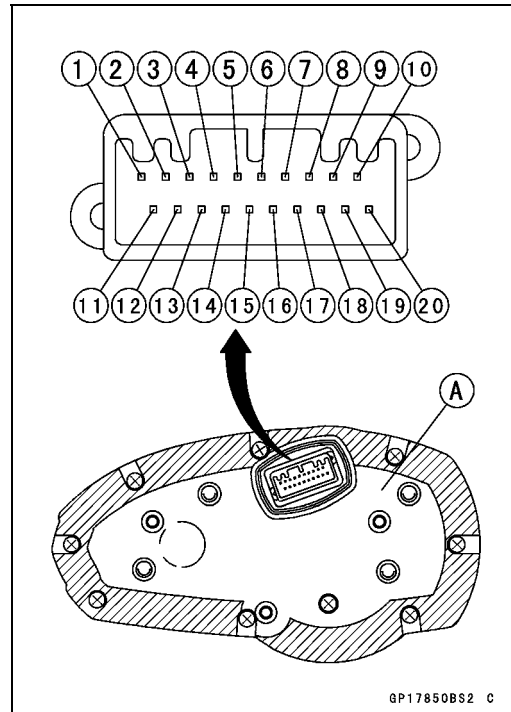

NOTICE

Do not drop the meter unit. Place the meter unit so that it faces upward. If the meter unit is left upside down or sideways for a long time or dropped, it will malfunction. Do not short each terminals.

Check 1: Meter Unit Primary Operation Check

- Using the auxiliary leads, the 12 V battery [A] to the meter unit connector as follows.
 - Connect the battery positive (+) terminal to the terminal [14].
 - Connect the battery negative (-) terminal to the terminal [12].

- Check that the tachometer needle [A] momentarily points their last readings and back to the minimum position.
- ★ If the meter unit does not work, replace the meter assembly.

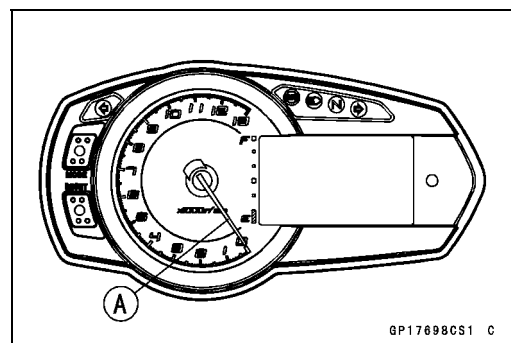
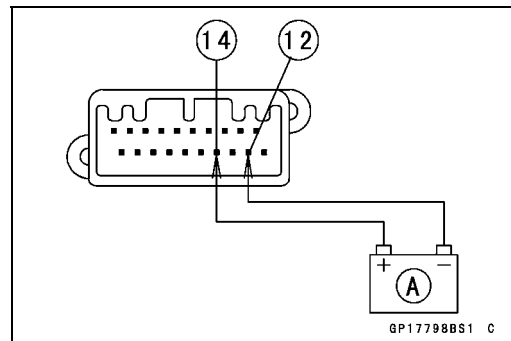

Meter, Gauge, Indicator Unit

- Connect the terminal [15] to the battery (+) terminal.

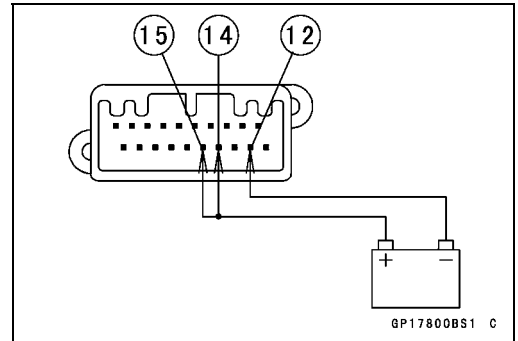

- Check the following items.
 - The tachometer needle momentarily points their last readings and back to the minimum position.
 - All the LCD (Liquid Crystal Display) segments [A] and warning indicator light (LED) [B] blink 1 time, then appear for about 1 second.
 - After the following LCD (Liquid Crystal Display) will display the action (1, 2) within about 2 seconds.

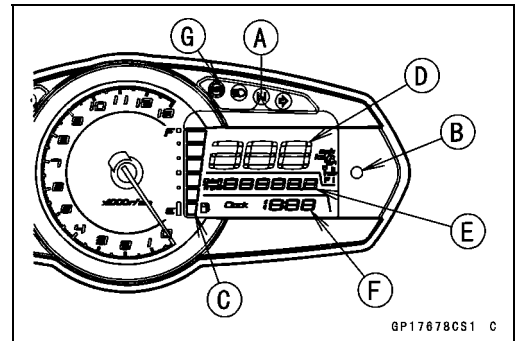

	Fuel Gauge [C]	Speedometer [D], Odometer [E] and Clock [F]
Action 1	Segments appear from up.	Segments appear from left.
Action 2	Segments display current valve.	Segments display current valve.

- The all segments of the fuel gauge in the display will flash. (This function is Fuel Level Sensor Line Self-Diagnosis Mode. Refer to Fuel Level Sensor Line Self-Diagnosis Mode Inspection.)
- The ABS indicator light (LED) [G] goes on. (Equipped Models)

★ If the meter unit does not work, replace the meter assembly.

NOTE

○ Currently, the wiring that relates to flashing has been disconnected for the meter is removed from main harness. Therefore, the above flash has occurred.

- Disconnect the terminal [15].
- All the LCD segments and LED warning indicator lights disappear.
- ★ If the meter unit does not work, replace the meter assembly.

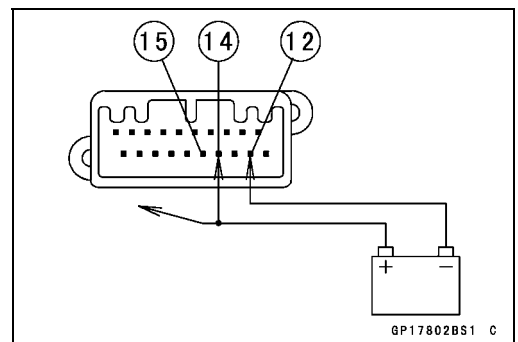

16-74 ELECTRICAL SYSTEM

Meter, Gauge, Indicator Unit

Check 2: Meter Communication Line (Service Code 39) Check

- Connect the leads in the same circuit as Check 1.
- Wait 10 seconds and the FI in the display and warning indicator light (LED) flash.

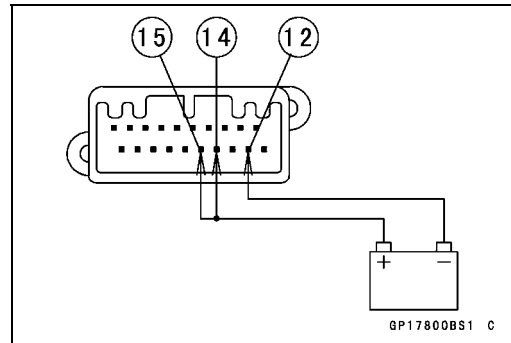

- Set the ODO mode [A] by pushing the MODE button [B].
- Push the MODE button for more than 2 seconds.

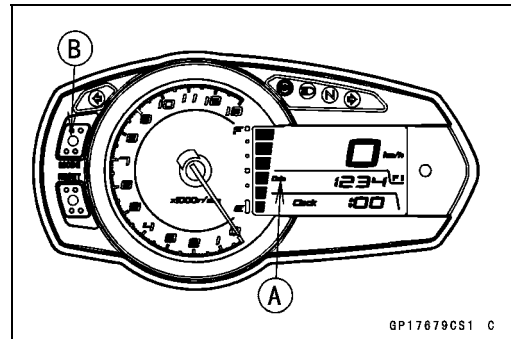

- Check the following items.
 - The number 39 [A] and FI [B] in the display appear and flash.
 - The warning indicator light (LED) [C] flashes.
- Push the MODE button for more than 2 seconds.
- Check the following items.
 - The display returns ODO mode from number 39.
 - The FI in the display and warning indicator light (LED) flash.
- ★ If the meter unit does not work, replace the meter assembly.

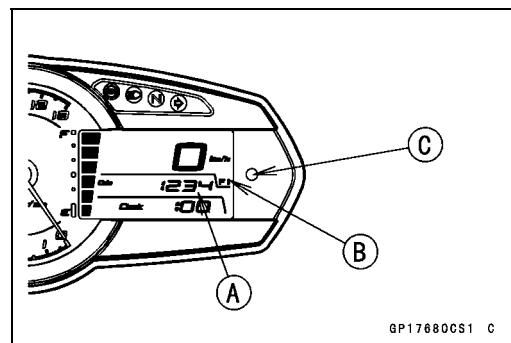

NOTE

- The number 39 is service code of Self-Diagnosis (see Fuel System chapter). It is the service code of the meter communication line error.
- The number 39 and FI in the display disappear when the meter unit is connected to main harness of the normal motorcycle.

Check 3: MODE Button Operation Check

- Connect the leads in the same circuit as Check 1.

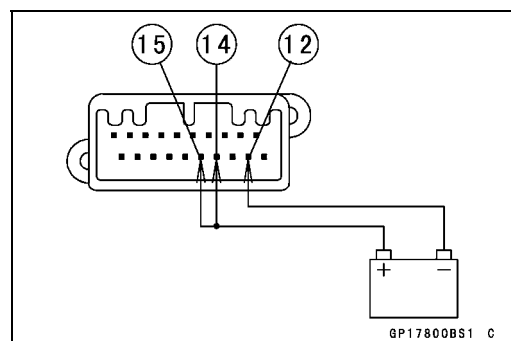

Meter, Gauge, Indicator Unit

- By pushing the MODE button [A] each time, check that the display [B] changes as follows.

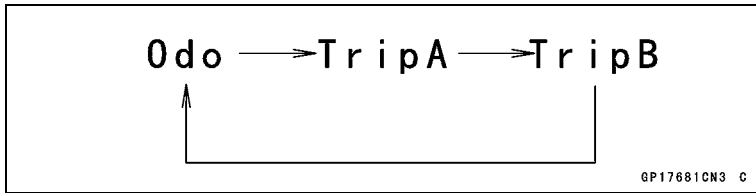

- ★ If the display function does not work, replace the meter assembly.

Check 4: Clock Setting Check

- Connect the leads in the same circuit as Check 1.

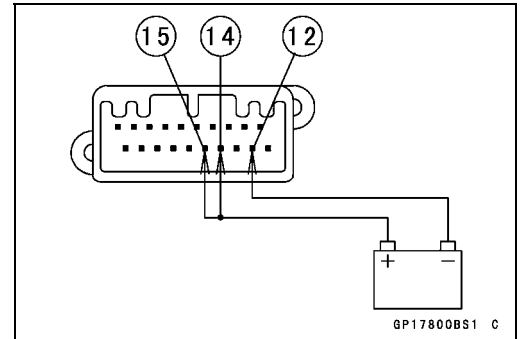
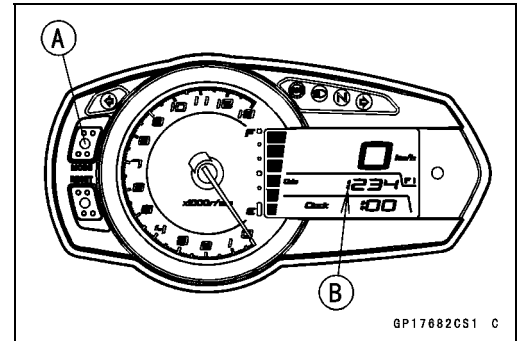

- Set the ODO mode [A] by pushing the MODE button [B].
- Push the RESET button [C] for more than two seconds.
- The clock setting menu (hour and minute) [D] should flash.
- Push the RESET button.

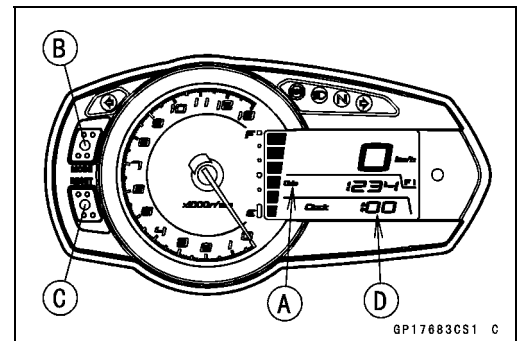

- The hour display [A] starts flashing.
- By pushing the MODE button each time, check that the hour display changes.

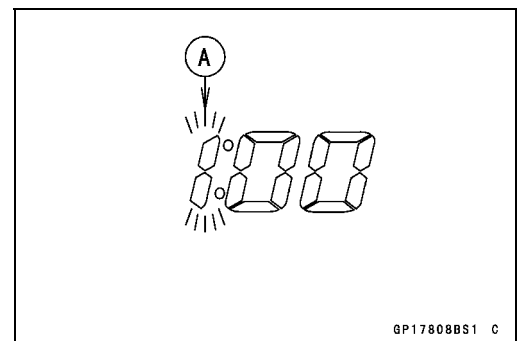

- By pushing the RESET button, check that the hour display decides and minute display [A] starts flashing.
- By pushing the MODE button each time, check that the minute display changes.

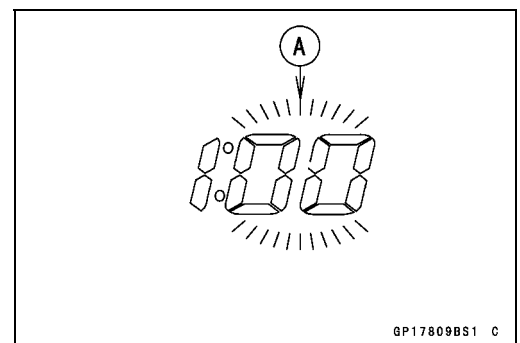

16-76 ELECTRICAL SYSTEM

Meter, Gauge, Indicator Unit

- By pushing the RESET button, check that the hour and minute display start flashing.
- By pushing the MODE button, check that the hour and minute display decide.
- When both hour and minute display is flashing, by pushing the RESET button, check that the hour display start flashing. This flashing returns the hour setting display.
- ★ If the display function does not work, replace the meter assembly.
- If the terminal 15 disconnected when the clock is setting, clock is set at time of that time.

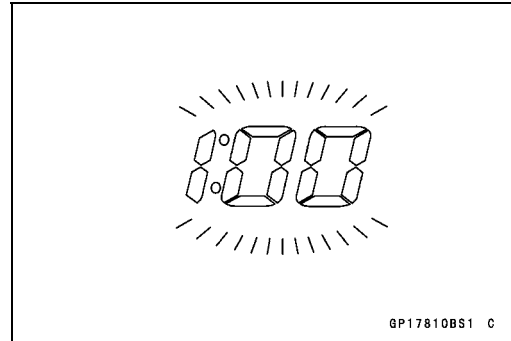

Check 5: Immobilizer Flashing Mode Inspection (Equipped Models)

- Connect the leads in the same circuit as Check 1.
- Disconnect the terminal [15].

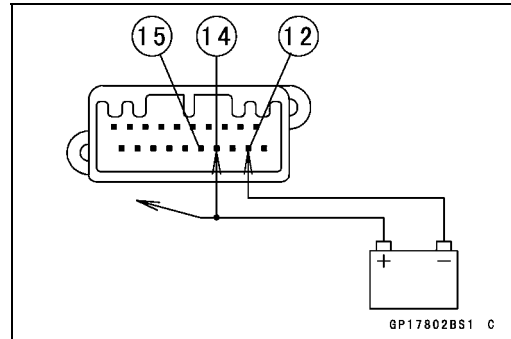

- Check that the warning indicator light (LED) [A] starts flashing (Immobilizer Warning Indicator Light Flashing Mode).
- Push the MODE [B] and RESET [C] buttons more than 2 second, within 20 seconds after the terminal [15] disconnected.
- Check that the warning indicator light (LED) goes on one second, and then the light goes off (Immobilizer Warning Indicator Light No Flashing Mode).

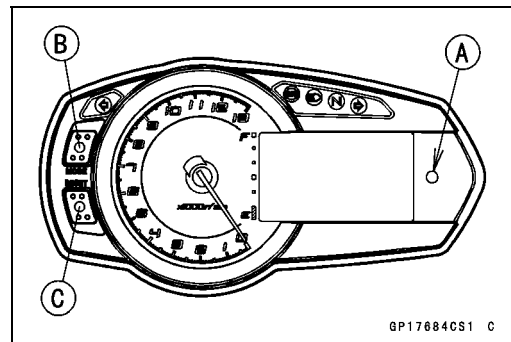

NOTE

○ For this inspection, be sure the battery is 12.2 V or more. Immobilizer Warning Indicator Light Flashing Mode does not work, when the battery voltage is less than 12 ± 0.2 V.

- Connect the terminal [15] to the battery (+) terminal.
- And then, disconnect the terminal [15].

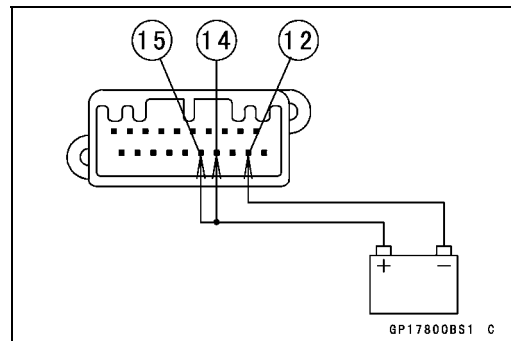

Meter, Gauge, Indicator Unit

- Push the MODE [A] and RESET [B] buttons more than 2 second, within 20 seconds after the terminal [15] disconnected.
- Check that the warning indicator light (LED) [C] goes on one second, and then the light starts flashing (Immobilizer Warning Indicator Light Flashing Mode).
- ★ If the meter function does not work, replace the meter assembly.

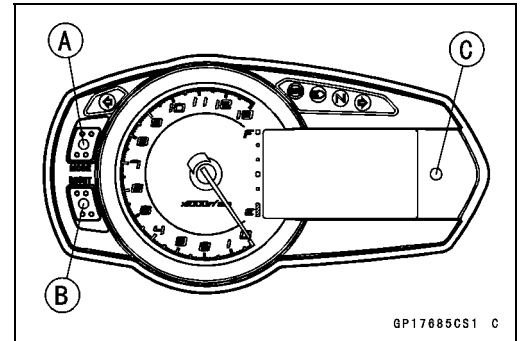

Check 6: Left Turn Signal Indicator Light (LED) Inspection

- Connect the leads in the same circuit as Check 1.
- Connect the terminal [1] to the battery (+) terminal.

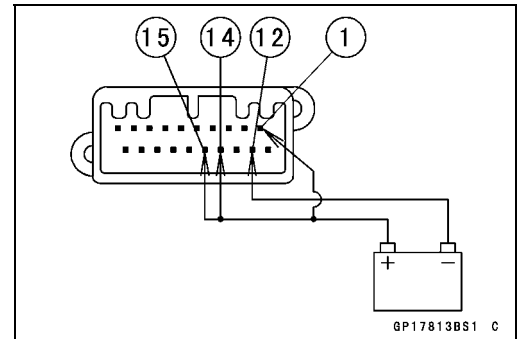

- Check that the left turn signal indicator light (LED) [A] goes on.
- ★ If the indicator light (LED) does not go on, replace the meter assembly.

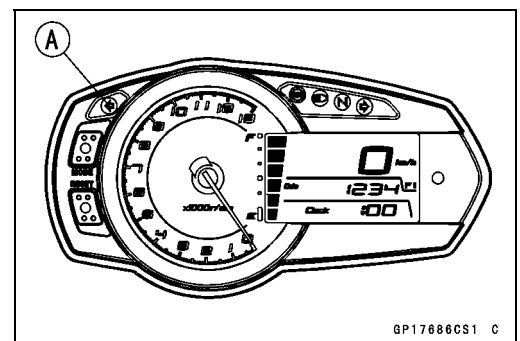

Check 7: High Beam Indicator Light (LED) Inspection

- Connect the leads in the same circuit as Check 1.
- Connect the terminal [8] to the battery (+) terminal.

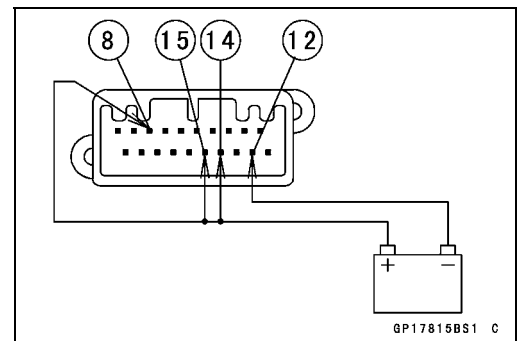

- Check that the high beam indicator light (LED) [A] goes on.
- ★ If the indicator light (LED) does not go on, replace the meter assembly.

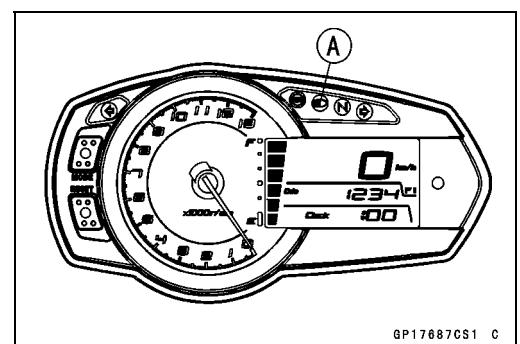

16-78 ELECTRICAL SYSTEM

Meter, Gauge, Indicator Unit

Check 8: Right Turn Signal Indicator Light (LED) Inspection

- Connect the leads in the same circuit as Check 1.
- Connect the terminal [9] to the battery (+) terminal.

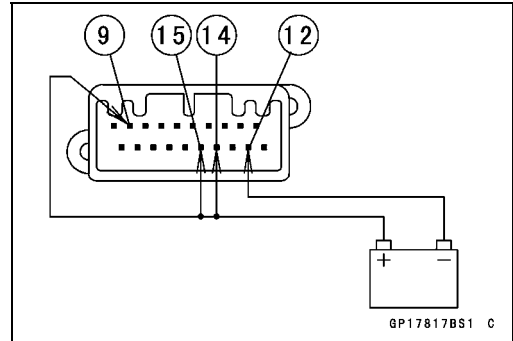

- Check that the right turn signal indicator light (LED) [A] goes on.
- ★ If the indicator light (LED) does not go on, replace the meter assembly.

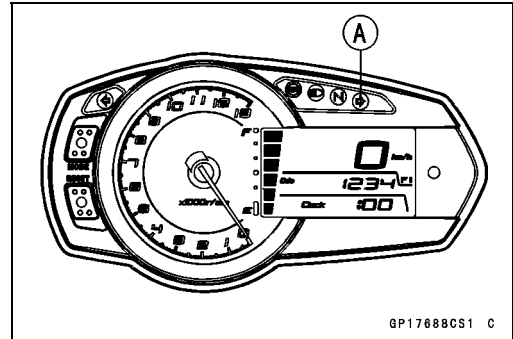

Check 9: Neutral Indicator Light (LED) Inspection

- Connect the leads in the same circuit as Check 1.
- Connect the terminal [10] to the battery (-) terminal.

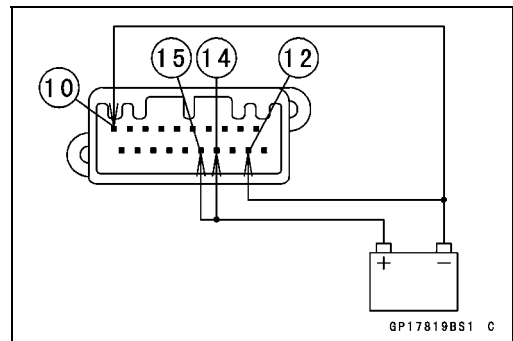

- Check that the neutral indicator light (LED) [A] goes on.
- ★ If the indicator light (LED) does not go on, replace the meter assembly.

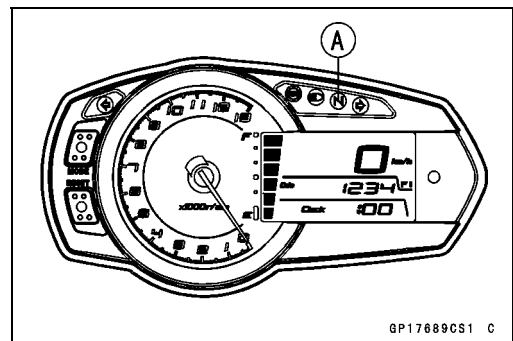

Check 10: ABS Indicator Light (LED) Inspection (Equipped Models)

- Connect the leads in the same circuit as Check 1.
- The ABS indicator light (LED) goes on.
- Connect the terminal [11] to the battery (-) terminal.

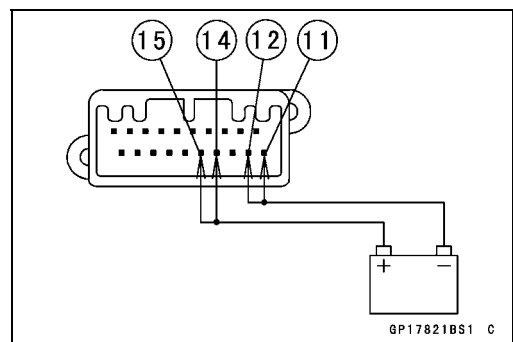

Meter, Gauge, Indicator Unit

- Check that the ABS indicator light (LED) [A] goes off.
- ★ If the indicator light (LED) does not go off, replace the meter assembly.

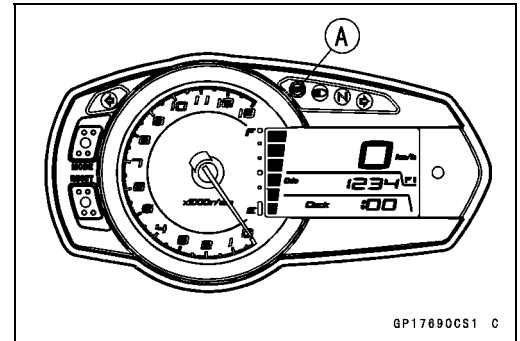

Check 11: Oil Pressure Warning Indicator Light (LED) Inspection

- Connect the leads in the same circuit as Check 1.
- Connect the terminal [20] to the battery (-) terminal.

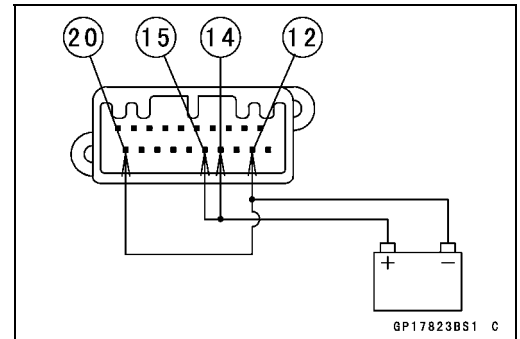

- Check that the oil symbol [A] and oil pressure warning indicator light (LED) [B] flash.
- ★ If the oil symbol and indicator light (LED) do not flash, replace the meter assembly.

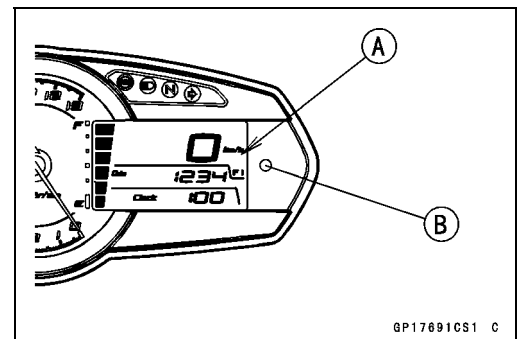

Check 12: Water Temperature Warning Indicator Light (LED)

- Connect the leads in the same circuit as Check 1.
- The “--” indication in the display of the water temperature meter appears.
- Connect the terminal [7] to the battery (-) terminal.

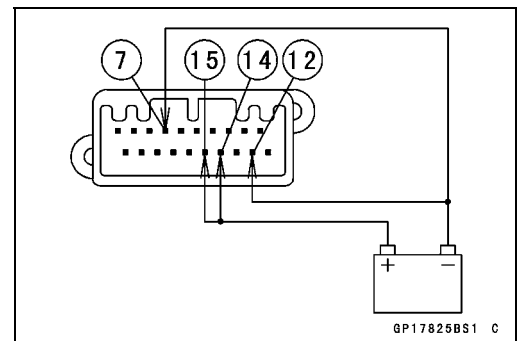

- Check that the water temperature symbol [A] and water temperature warning indicator light (LED) [B] flash.
- ★ If the water temperature symbol and indicator light (LED) do not flash, replace the meter assembly.

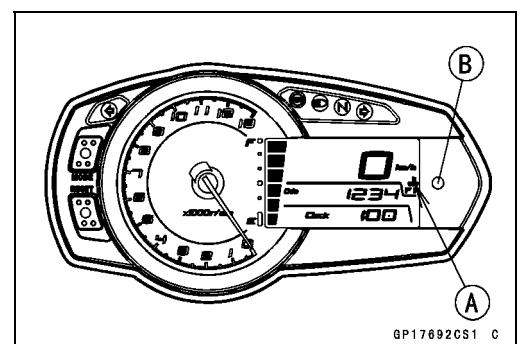

16-80 ELECTRICAL SYSTEM

Meter, Gauge, Indicator Unit

Check 13: Fuel Gauge Inspection

- Connect the leads in the same circuit as Check 1.
- The all segments of the fuel gauge in the display will flash.
- Connect the variable rheostat [A] to the terminal [16] and the battery (-) terminal.

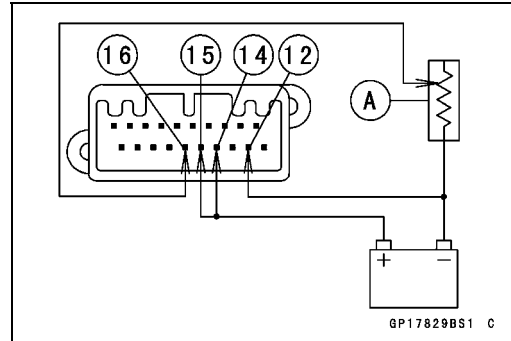

- Check that the segments number of the fuel level gauge [A] matches the resistance value of the variable rheostat.
- When the terminal [16] is connected, one segment in the fuel level gauge should appear about every 15 seconds.

Variable Rheostat Resistance (Ω)	Display Condition
10	6 segments go on
about 80	1 segment goes on
100	1 segment and Fuel Symbol [B] flash

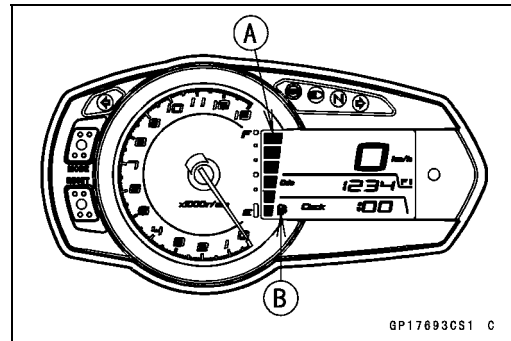

★ If the display function does not work, replace the meter assembly.

Check 14: Speedometer Inspection

- Connect the leads in the same circuit as Check 1.
- The speed equivalent to the input frequency is indicated in the oscillator [A], if the square wave is input into terminal [18].
- Indicates approximately 60 km/h if the input frequency is approximately 189 Hz.
- Indicates approximately 60 mph if the input frequency is approximately 303 Hz.
- ★ If the meter function does not work, replace the meter assembly.

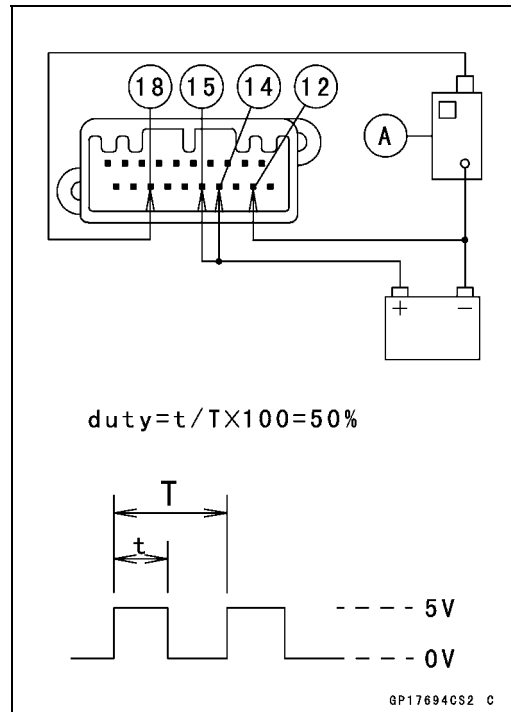

NOTE

- The input frequency of the oscillator adds the integrated value of the odometer.
- The integrated value of the odometer cannot be reset.

Check 15: Odometer Check

- Check the odometer with the speedometer check in the same way.
- ★ If value indicated in the odometer is not added, replace the meter unit.

NOTE

- The data is maintained even if the battery is disconnected.
- When the figures come to 999999, they are stopped and locked.

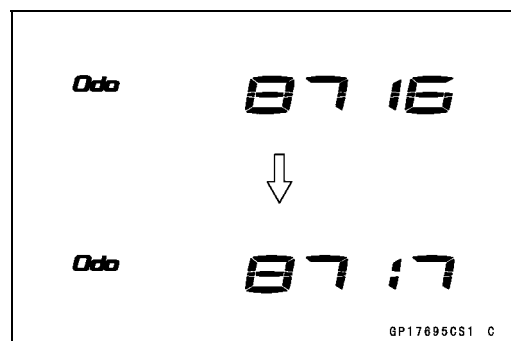

Meter, Gauge, Indicator Unit

Check 16: Trip A/B Meter Check

- Check the trip meter with the speedometer in the same way.
- ★ If value indicated in the trip meter is not added, replace the meter unit.
- Check that when the RESET button is pushed for more than two seconds, the figure display turns to 0.0.
- ★ If the figure display does not indicate 0.0, replace the meter unit.

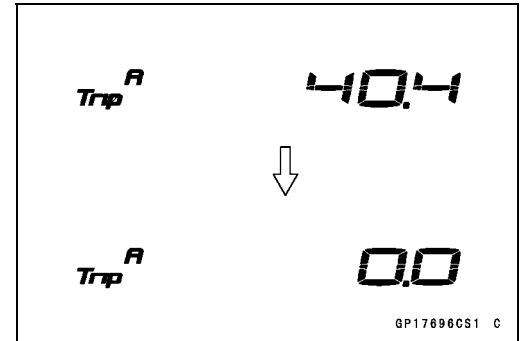

Check 17: Tachometer Inspection

- Connect the leads in the same circuit as Check 1.
- The engine speed (rpm) equivalent to the input frequency is indicated in the oscillator [A], if the square wave is input into terminal [19].
- Indicates approximately 4 000 rpm if the input frequency is approximately 133.3 Hz.
- ★ If the meter function does not work, replace the meter assembly.

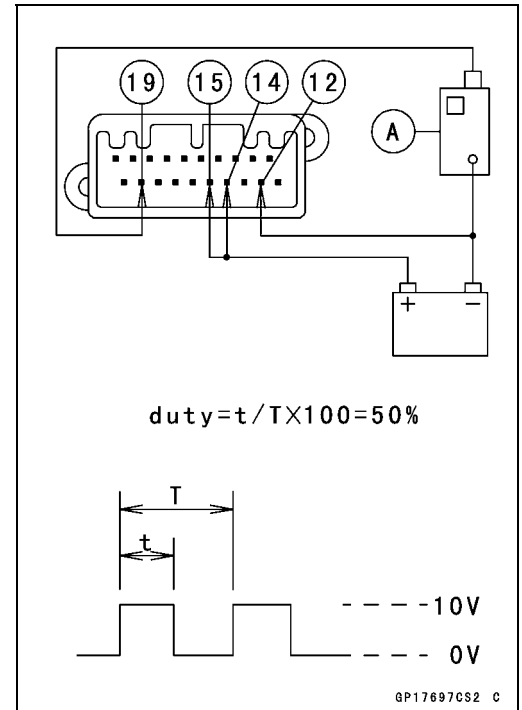

- Disconnect the terminal [15].
- Check that the tachometer needle [A] back to the minimum (0) position.
- ★ If the meter unit does not work, replace the meter assembly.

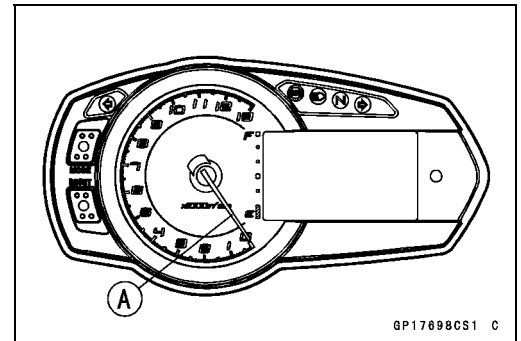

Fuel Level Sensor Line Self-Diagnosis Mode Inspection

NOTE

- Usually when the open or short of the fuel level sensor circuit is detected, it becomes the Fuel Level Sensor Line Self-Diagnosis Mode.
- The all segments of the fuel gauge [A] in the display will flash. (This function is Fuel Level Sensor Line Self-Diagnosis Mode.)
- ★ If the meter enters the self-diagnostic mode when the meter is installed in the motorcycle, check the fuel level sensor (see Fuel Level Sensor Inspection) and wiring.
- ★ If the fuel level sensor and wiring are good, replace the meter assembly.

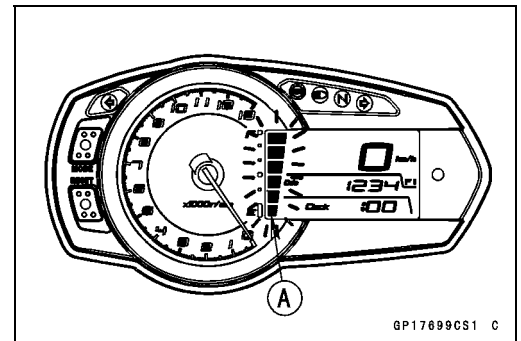

16-82 ELECTRICAL SYSTEM

Meter, Gauge, Indicator Unit

Meter Circuit

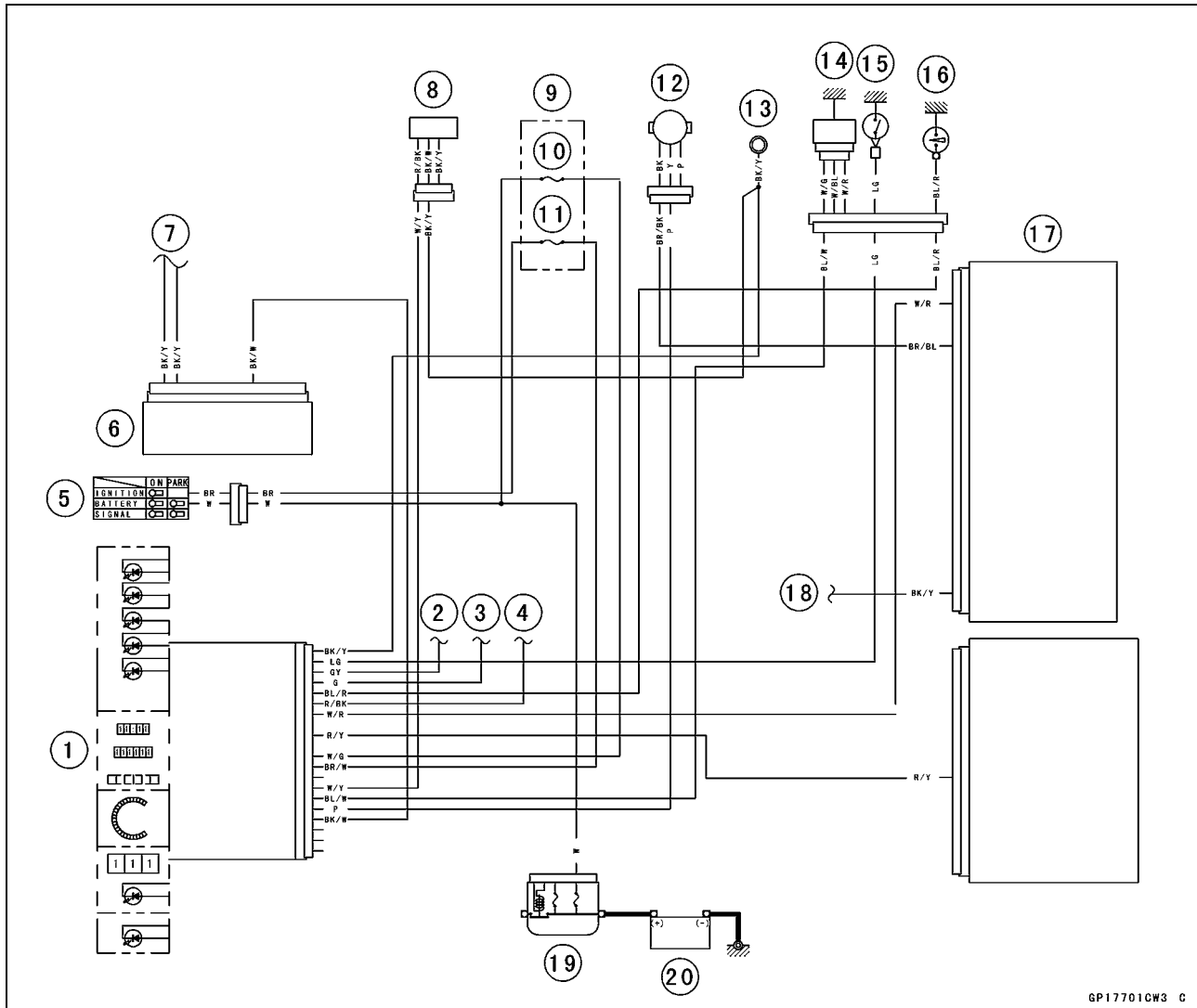

GP17701CW3 C

- | | |
|---|------------------------------|
| 1. Meter Unit | 11. Ignition Fuse 15 A |
| 2. to Turn Signal Switch (Right) | 12. Speed Sensor |
| 3. to Turn Signal Switch (Left) | 13. Meter Ground |
| 4. to Dimmer Switch and Passing Button
(Equipped Models) | 14. Water Temperature Sensor |
| 5. Ignition Switch | 15. Neutral Switch |
| 6. ABS Hydraulic Unit (Equipped Models) | 16. Oil Pressure Switch |
| 7. to France Ground | 17. ECU |
| 8. Fuel Level Gauge | 18. to Frame Ground |
| 9. Fuse Box 2 | 19. Main Fuse 30 A |
| 10. Meter Fuse 10 A | 20. Battery 12 V 8 Ah |

Immobilizer System (Equipped Models)

This motorcycle is equipped with an immobilizer system to protect the motorcycle from theft. This system provides a theft proof device by means of matching a code between the inbuilt key transponder and ECU (Electronic Control Unit). If the code does not match, ignition system, injectors, subthrottle valve actuator and exhaust butterfly valve actuator will not operate and the engine will not start.

Abstract

- Do not keep more than one immobilizer key of any system on a key ring. Jamming of the key code signal may occur and the operation of the system may be affected.
- The warning indicator light (LED) will flash for a period of 24 hours once the ignition switch has been switched off and the key removed. This flashing can be set to on or off as desired by holding the left and right buttons down for two seconds within twenty seconds of switching the ignition off.
- If all coded keys are lost the ECU and ignition switch will have to be replaced.
- The immobilizer system can not function until the ignition key code is registered in the ECU.
- A total of five keys can be registered in the ECU at any one time.

Operational Cautions

1. Do not put two keys of any immobilizer system on the same key ring.
2. Do not submerge any key in water.
3. Do not expose any key to excessively high temperature.
4. Do not place any key close to magnet.
5. Do not place a heavy item on any key.
6. Do not grind any key or alter its shape.
7. Do not disassemble the plastic part of any key.
8. Do not drop the key and/or apply any shocks to the key.
9. When a ignition key is lost, the user should go to his dealer to invalidate the lost key registration in the ECU.
10. When the all ignition key is lost, the user should go to his dealer and have a new ECU installed and register the ignition keys.

NOTE

○No.9 and 10 are strongly recommended to the customer to ensure security of the motorcycle.

Key Registration

Case 1: When additional spare ignition key is required.

- Prepare a new spare ignition key.
- Cut the key in accordance with the shape of the current ignition key.
- Remove:
 - Front Seat (see Front Seat Removal in the Frame chapter)
- Remove the immobilizer/Kawasaki diagnostic system connector cap [A].
- Connect the key registration adapter [A] and key registration unit [B].

Special Tools - Key Registration Unit: 57001-1582

Key Registration Adapter: 57001-1746

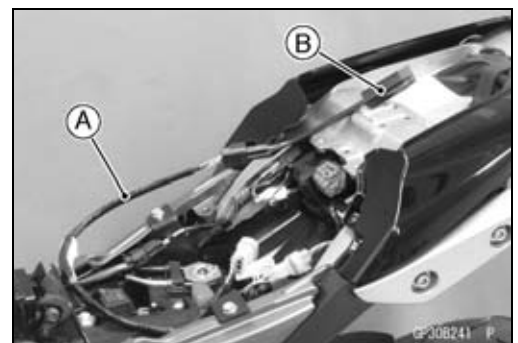

16-84 ELECTRICAL SYSTEM

Immobilizer System (Equipped Models)

- Insert the registered ignition key into the ignition switch, and turn it to ON.

Verified

- The warning indicator light (LED) and the immobilizer warning symbol [A] blink to display the registration mode (go to the next step).

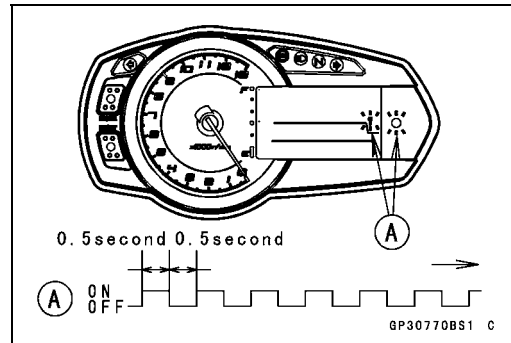

Not Verified

- The warning indicator light (LED) and the immobilizer warning symbol [A] blink to display the collation error (refer to the following failure illustrations).

Immobilizer Amplifier Failure

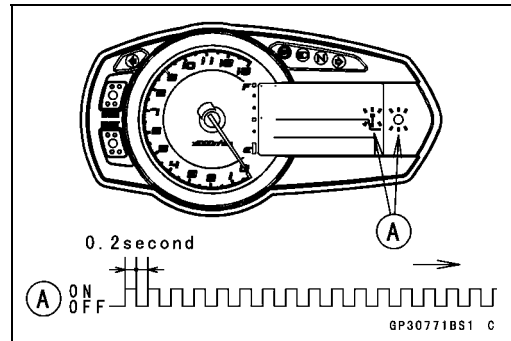

Registered Ignition Key Collation Error

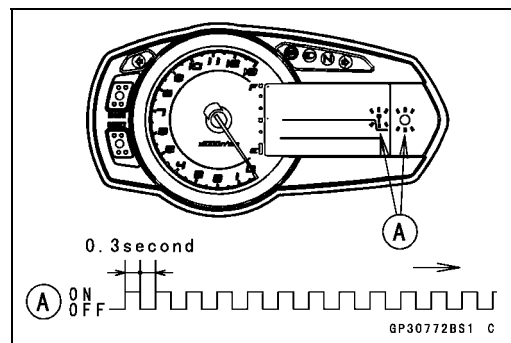

- Turn to OFF the ignition switch and remove the registered ignition key.
- ★ If there are other registered ignition keys, they should all do the procedure above.
- The warning indicator light (LED) [A] then blinks for 15 seconds; it means the ECU is in the registration mode.
- The immobilizer warning symbol [B] disappears.
- After 15 seconds, the ECU ends the registration mode and stops blinking the warning indicator light (LED).

NOTE

- Insert and turn on the next key between 15 seconds that the ECU is in the registration mode.
- When a registration mode was ended, do the registered ignition key(s) verification procedure over again to restart it. This applies to all ignition key registration.

- Insert the ignition key 1 into the ignition switch, and turn it to ON.

NOTE

- Keep other ignition keys away from the immobilizer antenna.

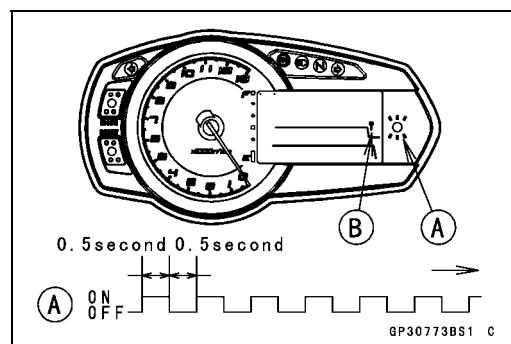

Immobilizer System (Equipped Models)

○If there is any problem in the registration, the warning indicator light (LED) and the immobilizer warning symbol [A] blink to display the collation error.

Immobilizer Amplifier Failure

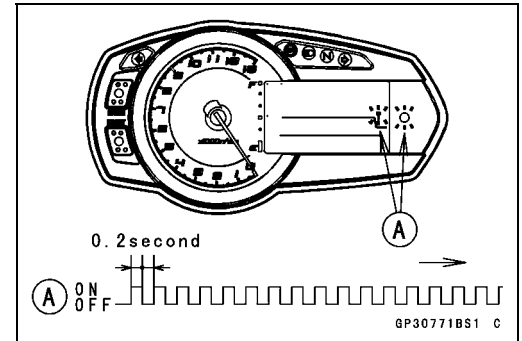

When Registered Ignition Key is Inserted.

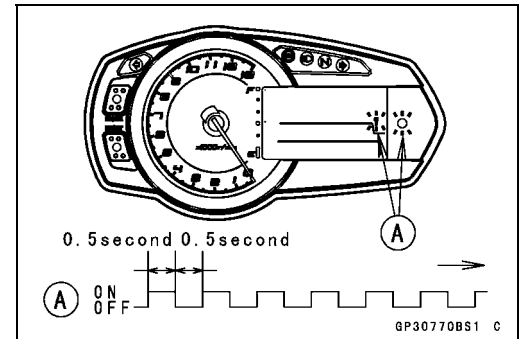

Ignition Key Collation Error

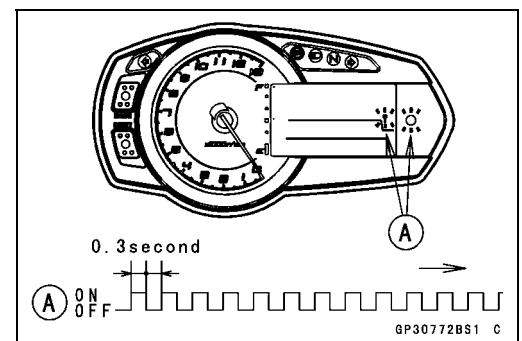

- The ignition key 1 is successfully registered in the ECU.
- The warning indicator light (LED) and the immobilizer warning symbol [A] blink 3 times and stop for 1 second and then repeat this cycle.

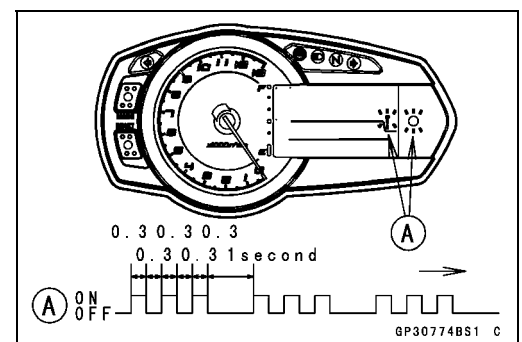

- Turn to OFF the ignition switch and remove the ignition key 1.
- The immobilizer warning symbol [A] disappears.
- The warning indicator light (LED) then blinks for 15 seconds.
- After 15 seconds, the ECU ends the registration mode and stops blinking the warning indicator light (LED).

NOTE

○ This procedure registered the registered ignition key and one ignition key.

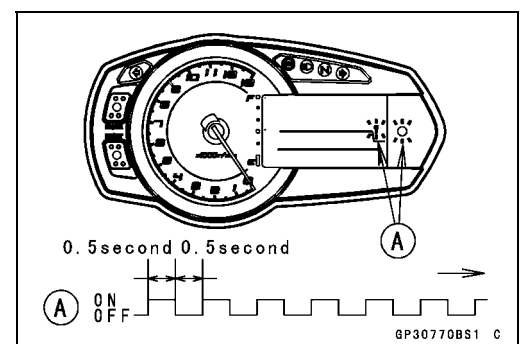

- ★ If more keys registration is needed, go to next procedures within the registration mode.

16-86 ELECTRICAL SYSTEM

Immobilizer System (Equipped Models)

- Insert the ignition key 2 to the ignition switch and turn it to ON.
- If there is any problem in the registration, the warning indicator light (LED) and the immobilizer warning symbol [A] blink to display the collation error.
Immobilizer Amplifier Failure

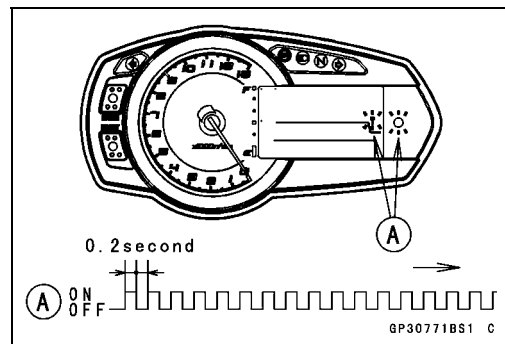

When Registered Ignition Key is Inserted.

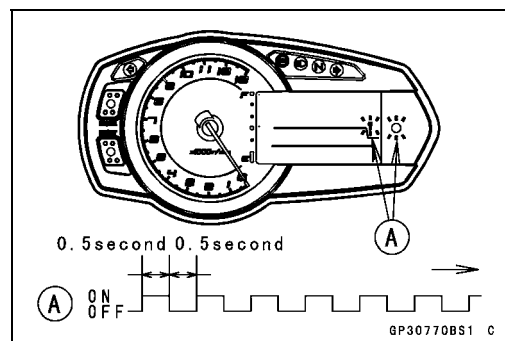

Ignition Key Collation Error

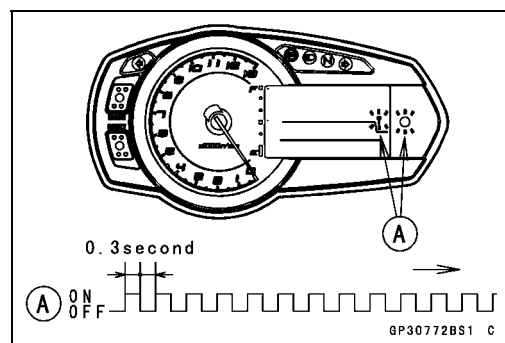

- The ignition key 2 is successfully registered in the ECU.
- The warning indicator light (LED) and the immobilizer warning symbol [A] blink 4 times and stop for 1 second and then repeat this cycle.
- This procedure has registered the 2 ignition keys.
- Continue with the procedure if necessary to register an additional one ignition key.

NOTE

○ The ECU can store up the five key codes.

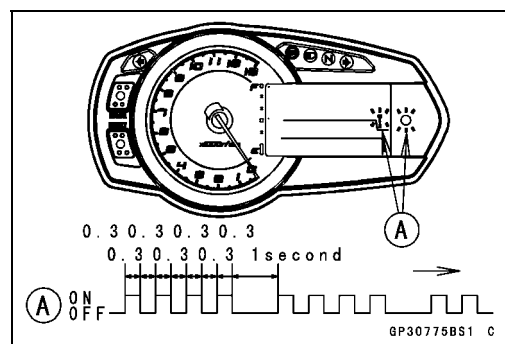

Ignition Key Indicator Flashes

	Indicator Light Blinks	Indicator Light Stops	Remarks
Ignition Key 3	5 times	1 second	Repeat

- Turn to OFF the ignition switch and wait for period of more than 15 seconds.
- The registration mode automatically ends.

Immobilizer System (Equipped Models)

- The warning indicator light (LED) [A] goes off.

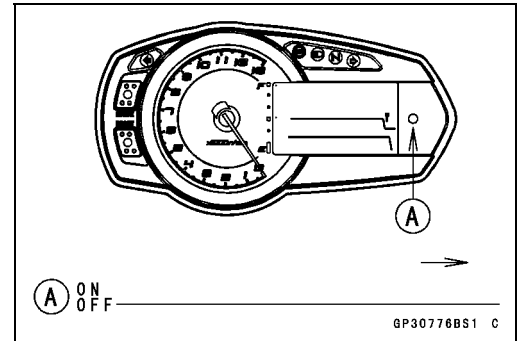

- Remove the key registration unit, key registration adapter and install the immobilizer/Kawasaki diagnostic system connector cap.

NOTE

- Turn the ignition switch to ON with the registered ignition key.
- Check that the engine can be started using all registered ignition keys.

16-88 ELECTRICAL SYSTEM

Immobilizer System (Equipped Models)

Spare Ignition Key Registration Flow Chart

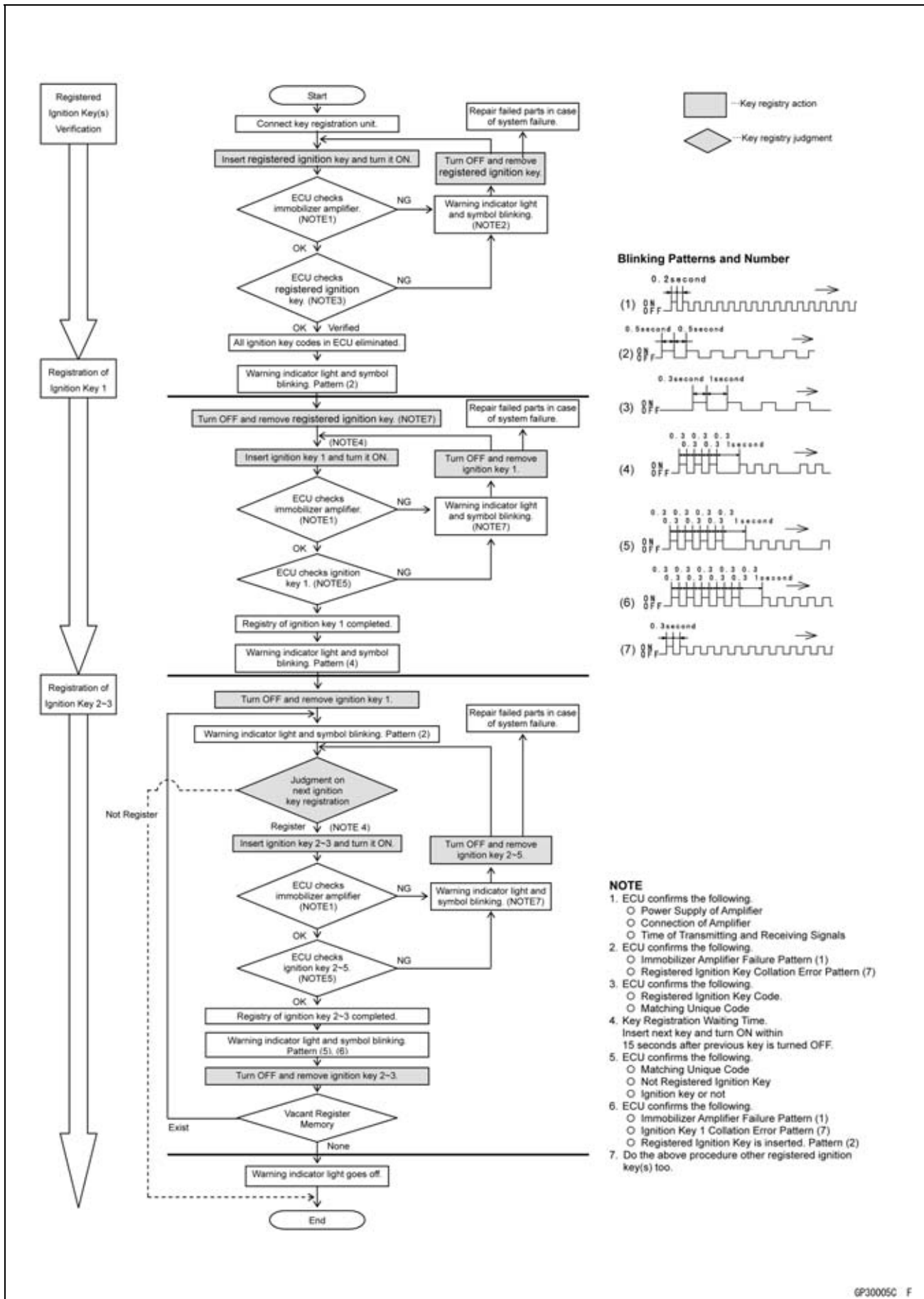

Immobilizer System (Equipped Models)

Case 2: When the ignition switch is faulty and has to be replaced.

- Prepare a new ignition switch [A] and two new ignition keys [B].
- These parts are available as a set. Prepare the current registered ignition key [C].

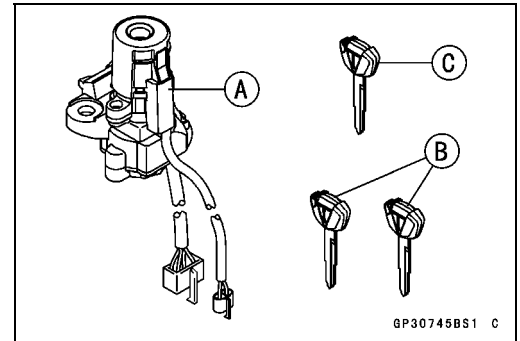

- Remove:
 - Ignition Switch (see Immobilizer System Parts Replacement)
 - Front Seat (see Front Seat Removal in the Frame chapter)
- Remove the immobilizer/Kawasaki diagnostic system connector cap.
- Connect the key registration adapter [A] and key registration unit [B].

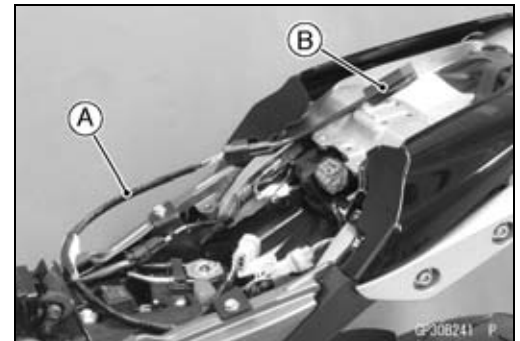

Special Tools - Key Registration Unit: 57001-1582
Key Registration Adapter: 57001-1746

- Connect:
 - New Ignition Switch Lead Connector [A]
 - Immobilizer Antenna Lead Connector [B] (of Current Ignition Switch)

NOTE

- Keep the antenna [C] more than 15 cm (5.9 in.) from the new ignition switch [D].

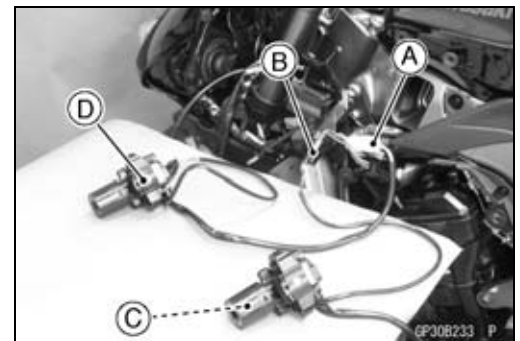

- Insert the current registered ignition key [A] into the current ignition switch [B].
- Insert the new ignition key 1 [C] into the new ignition switch [D], and turn it to ON.

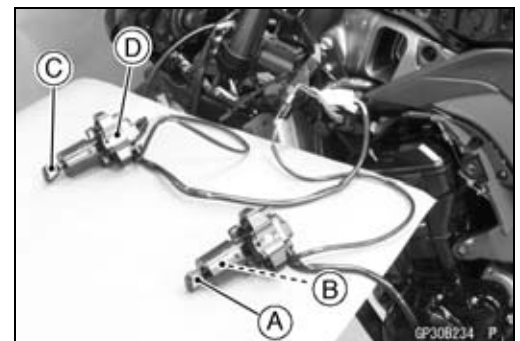

16-90 ELECTRICAL SYSTEM

Immobilizer System (Equipped Models)

Verified

○The warning indicator light (LED) and the immobilizer warning symbol [A] blink to display the ECU is in the registration mode (go to the next step).

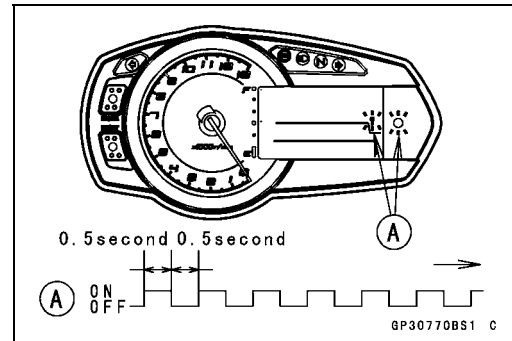

Not Verified

○The warning indicator light (LED) and the immobilizer warning symbol [A] blink to display the collation error. Immobilizer Amplifier Failure

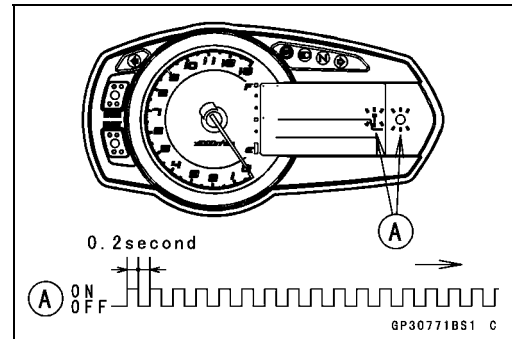

Registered Ignition Key Collation Error

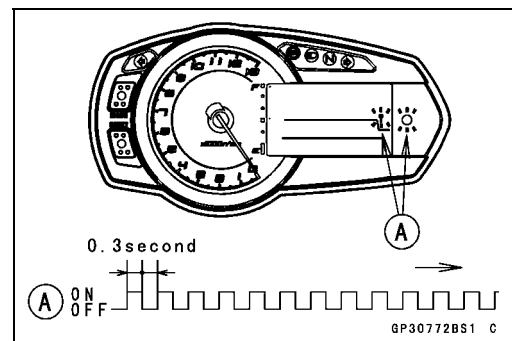

- Turn to OFF the ignition switch and remove the new ignition key 1.
- The immobilizer warning symbol [B] disappears.
- The warning indicator light (LED) [A] then blinks for 15 seconds; it means the ECU is in the registration mode.
- After 15 seconds, the ECU ends the registration mode and stops blinking the warning indicator light (LED).

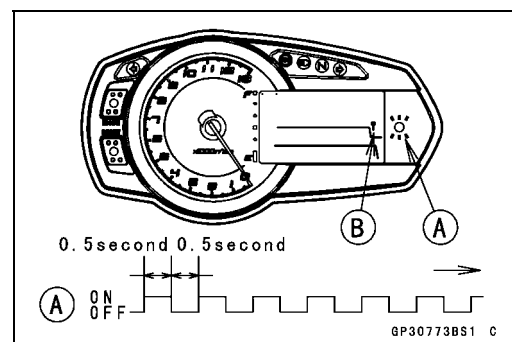

- Disconnect the antenna lead connector of the current ignition switch and connect the antenna lead connector of the new ignition switch [A].
- Insert the ignition key 1 [B] again into the new ignition switch, and turn it to ON.

NOTE

- Insert and turn on the ignition key within 15 seconds that the ECU is in the registration mode.
- When a registration mode was ended, do the registered ignition key verification procedure over again to restart it. This applies to all ignition key registration.
- Keep other ignition keys away from the immobilizer antenna.

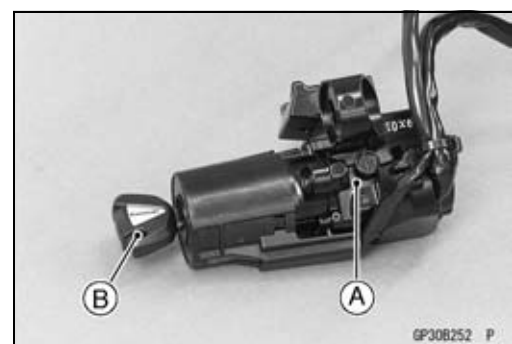

Immobilizer System (Equipped Models)

- If there is any problem in the registration, the warning indicator light (LED) and the immobilizer warning symbol [A] blink to display the collation error.
Immobilizer Amplifier Failure

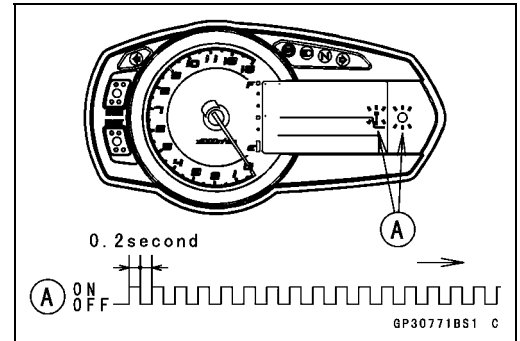

When Registered Ignition Key is Inserted.

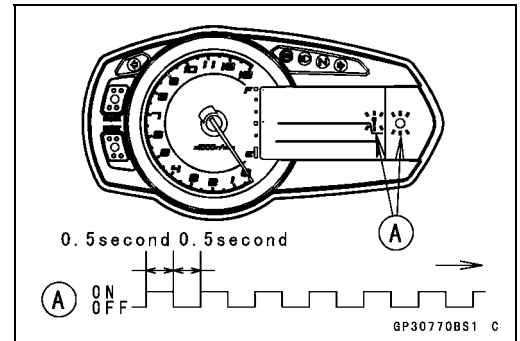

Ignition Key Collation Error

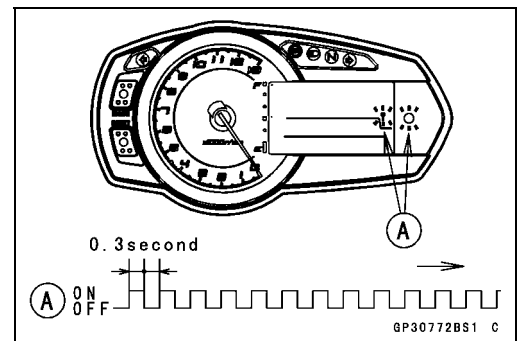

- The ignition key 1 is successfully registered in the ECU.
- The warning indicator light (LED) and the immobilizer warning symbol [A] blink 3 times and stop for 1 second and then repeat this cycle.

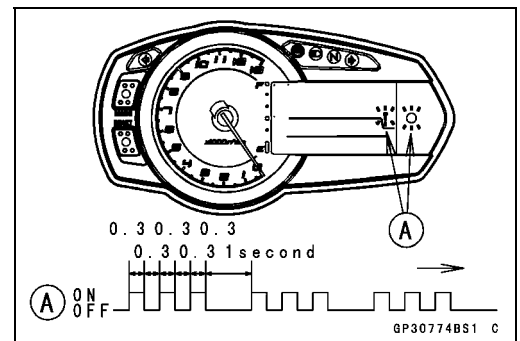

- Turn to OFF the ignition switch and remove the ignition key 1.
- The immobilizer warning symbol [B] disappears.
- The warning indicator light (LED) [A] then blinks for 15 seconds.
- After 15 seconds, the ECU ends the registration mode and stops blinking the warning indicator light (LED).

NOTE

- This procedure registered the registered ignition key and one ignition key.

- ★ If more keys registration is needed, go to next procedures within the registration mode.
- Insert the ignition key 2 into the ignition switch, and turn it to ON.

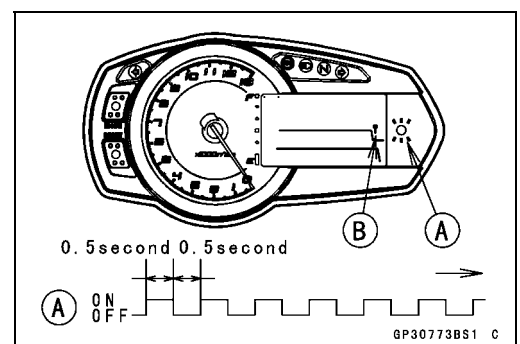

16-92 ELECTRICAL SYSTEM

Immobilizer System (Equipped Models)

○ If there is any problem in the registration, the warning indicator light (LED) and the immobilizer warning symbol [A] blink to display the collation error.
 Immobilizer Amplifier Failure

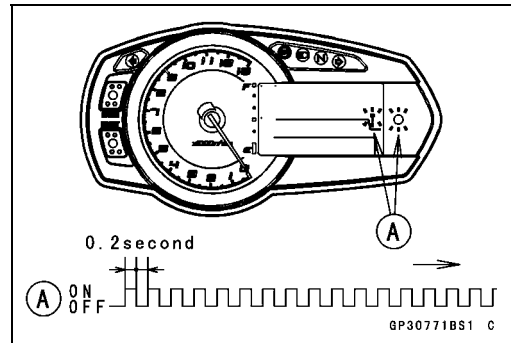

When Registered Ignition Key is Inserted.

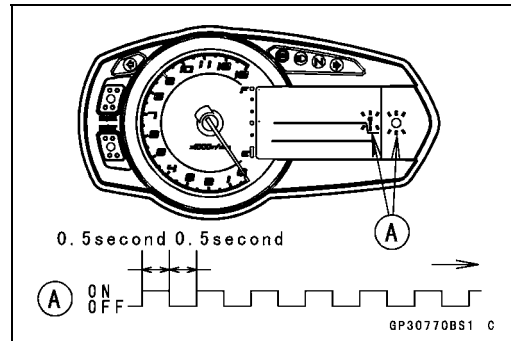

Ignition Key Collation Error

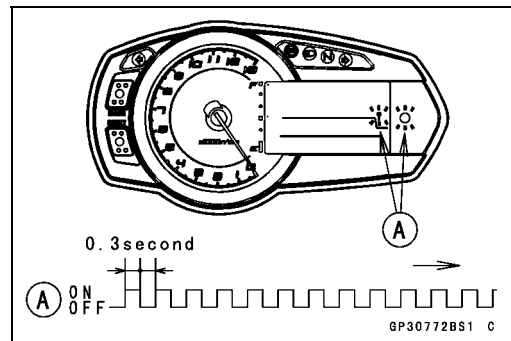

- The ignition key 2 is successfully registered in the ECU.
- The warning indicator light (LED) and the immobilizer warning symbol [A] blink 4 times and stop for 1 second and then repeat this cycle.
- This procedure has registered the registered ignition key and 2 ignition keys.
- Turn to OFF the ignition switch and wait for period of more than 15 seconds.
- The registration mode automatically ends.

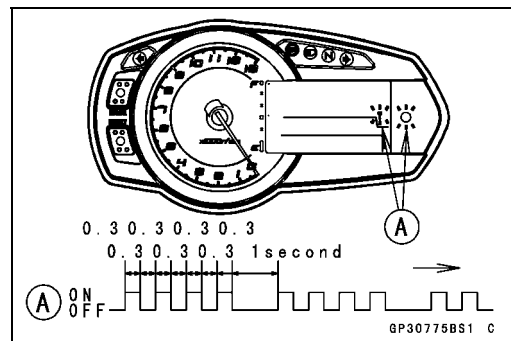

- The warning indicator light (LED) [A] goes off.

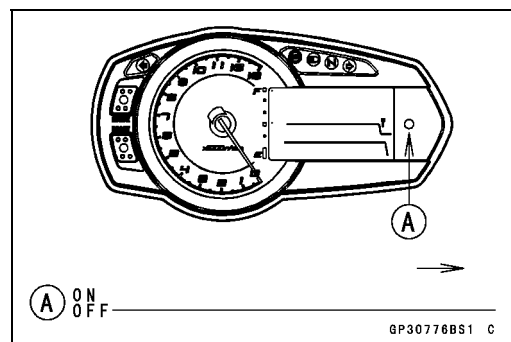

Immobilizer System (Equipped Models)

- Remove the key registration unit, key registration adapter and install the immobilizer/Kawasaki diagnostic system connector cap.

NOTE

- Turn the ignition switch to ON with the registered ignition key.
- Check that the engine can be started using all registered ignition keys.
- Install the new ignition switch (see Immobilizer System Parts Replacement).

Case 3: When the ECU is faulty and has to be replaced.

- Prepare a new ECU [A] and current ignition key(s) [B].

NOTE

- The key registration unit is not required.
- After replacing the ECU, be sure to register the 2 ignition keys. If the 2 keys are not registered, the engine can not be started.

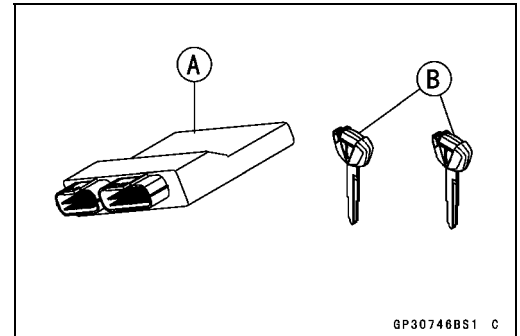

- Replace:
ECU (see Immobilizer System Parts Replacement)
- Insert the current registered ignition key into the ignition switch and turn it to ON.
- If there is any problem in the registration, the warning indicator light (LED) and the immobilizer warning symbol [A] blink to display the collation error.
Immobilizer Amplifier Failure

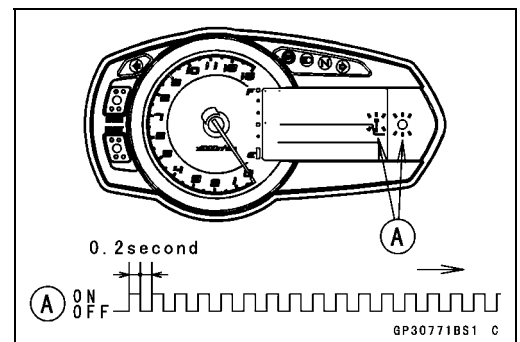

Registered Ignition Key Collation Error

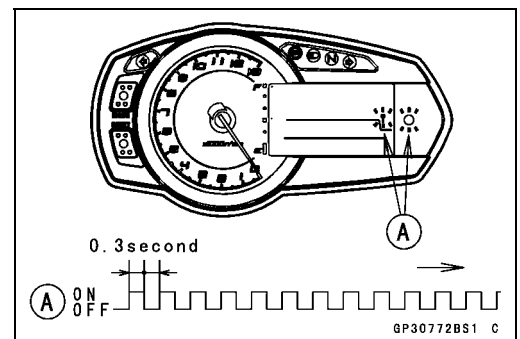

16-94 ELECTRICAL SYSTEM

Immobilizer System (Equipped Models)

- The registered ignition key is successfully registered in the ECU.
- The warning indicator light (LED) and the immobilizer warning symbol [A] blink 1 time and stop for 1 second and then repeat this cycle.

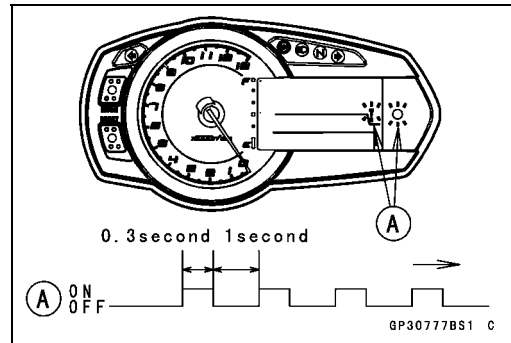

- Turn to OFF the ignition switch and remove the registered ignition key.
- The immobilizer warning symbol [B] disappears.
- The warning indicator light (LED) [A] then blinks for 15 seconds; it means the ECU is in the registration mode.
- After 15 seconds, the ECU ends the registration mode and stops blinking the warning indicator light (LED).

NOTE

- Insert and turn on the next key between 15 seconds that the ECU is in the registration mode.
 - When a registration mode was ended, do the registered ignition key verification procedure over again to restart it. This applies to all ignition key registration.
- Insert the other remaining registered ignition key into the ignition switch, and turn it to ON.

NOTE

- Keep other ignition keys away from the immobilizer antenna.
- If there is any problem in the registration, the warning indicator light (LED) and the immobilizer warning symbol [A] blink to display the collation error.
Immobilizer Amplifier Failure

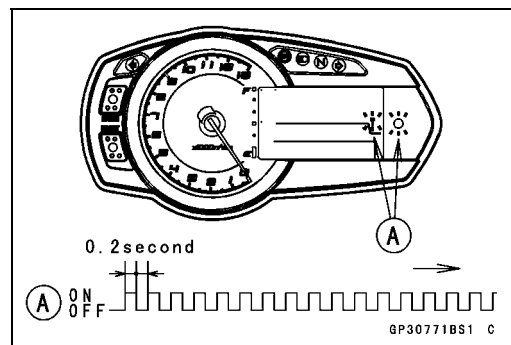
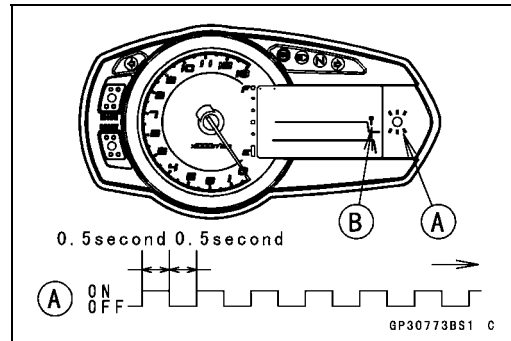

When Registered Ignition Key is Inserted.

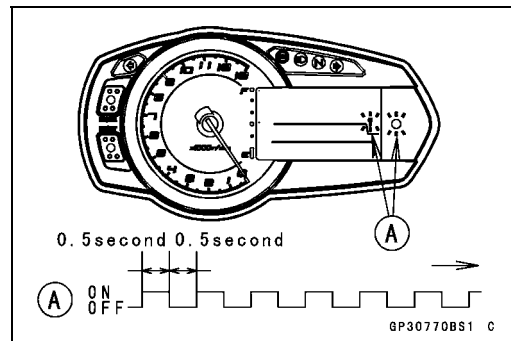

Immobilizer System (Equipped Models)

Ignition Key Collation Error

- The other remaining ignition key is registered in the ECU.
- The warning indicator light (LED) and the immobilizer warning symbol [A] blink 2 times and stop for 1 second and then repeat this cycle.

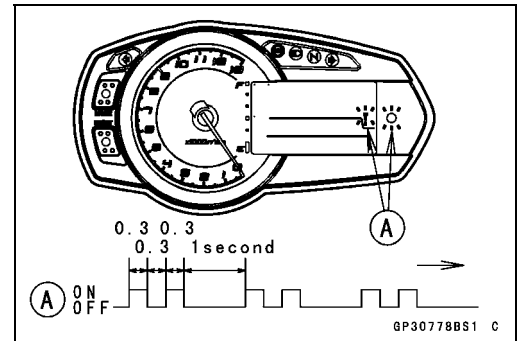
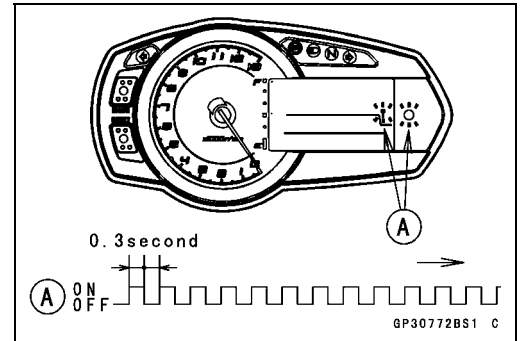

- Turn to OFF the ignition switch and remove the other remaining ignition key.
- The immobilizer warning symbol [B] disappears.
- The warning indicator light (LED) [A] then blinks for 15 seconds.
- After 15 seconds, the ECU ends the registration mode and stops blinking the warning indicator light (LED).

NOTE

- This procedure registered the registered ignition key and one ignition key.

- ★ If more keys registration is needed, go to next procedures within the registration mode.

- Insert the ignition key 1 into the ignition switch, and turn it to ON.

- If there is any problem in the registration, the warning indicator light (LED) and the immobilizer warning symbol [A] blink to display the collation error code.

Immobilizer Amplifier Failure

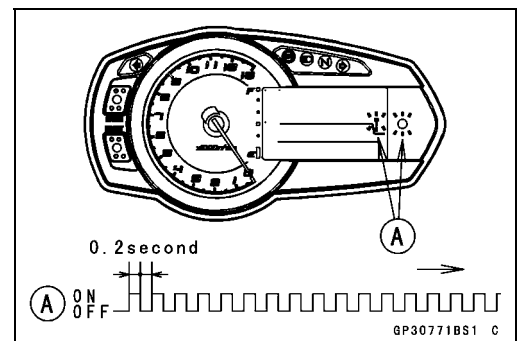
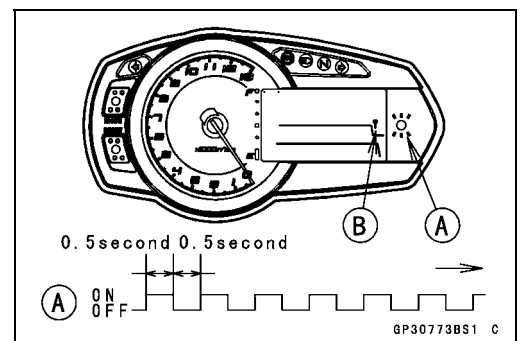

16-96 ELECTRICAL SYSTEM

Immobilizer System (Equipped Models)

When Registered Ignition Key is Inserted.

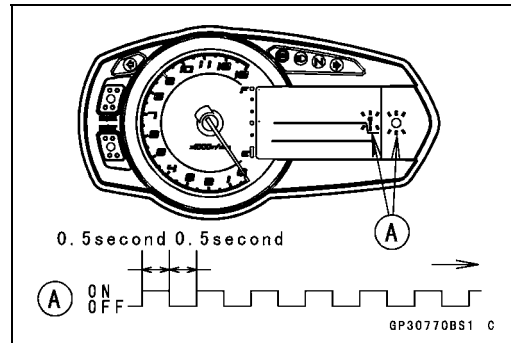

Ignition Key Collation Error

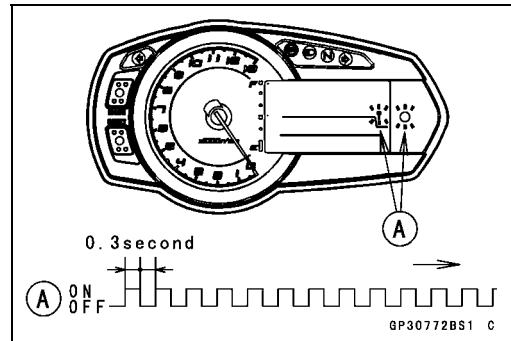

- The ignition key 1 is successfully registered in the ECU.
- The warning indicator light (LED) and the immobilizer warning symbol [A] blink 3 times and stop for 1 second and then repeat this cycle.
- This procedure has registered the registered ignition key and 2 ignition keys.
- Turn to OFF the ignition switch and wait for period of more than 15 seconds.
- The registration mode automatically ends.

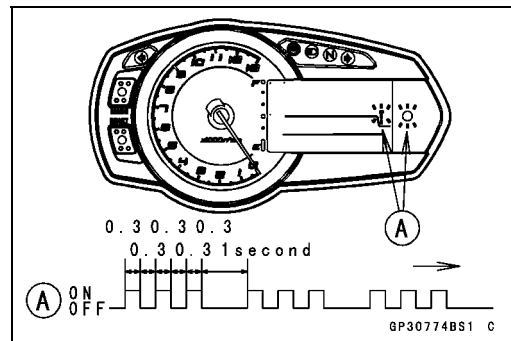

- The warning indicator light (LED) [A] goes off.

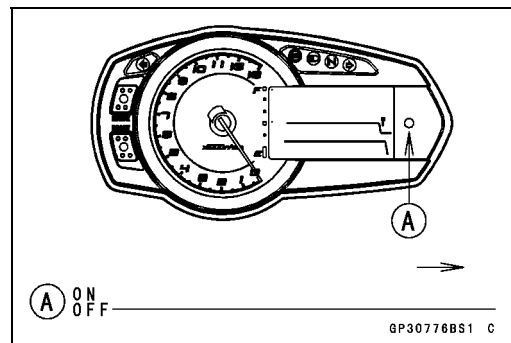

NOTE

- Turn the ignition switch to ON with the registered ignition key.
- Check that the engine can be started using all registered ignition keys.

Immobilizer System (Equipped Models)

Case 4: When all registered ignition keys are faulty or lost.

The all registered ignition keys replacement is considered very rare case. However if it is required, the following is necessary.

NOTE

- The ECU must be replaced with a new one because the registered ignition key code that is registered in the current ECU can not be rewritten.

- Prepare a new ECU [A] and 2 new ignition keys [B].

NOTE

- The key registration unit is not required.
- The key registration process is same as the case 3.

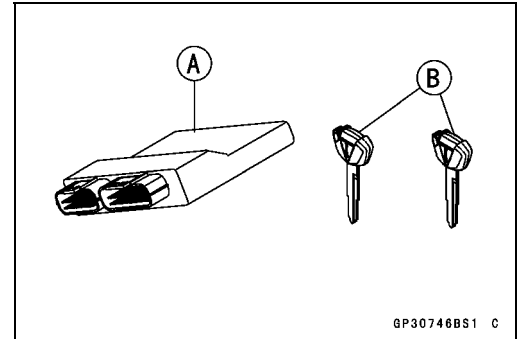

- Insert the first ignition key into the ignition switch and turn it ON.

- If there is any problem in the registration, the warning indicator light (LED) and the immobilizer warning symbol [A] blink to display the collation error.
Immobilizer Amplifier Failure

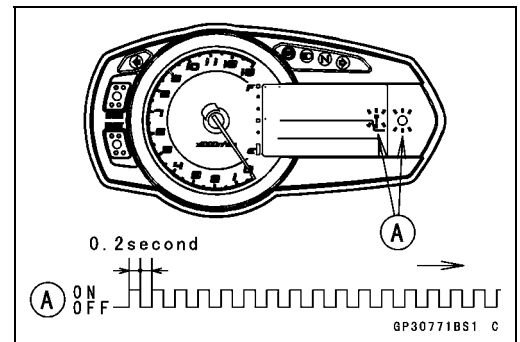

Ignition Key Collation Error

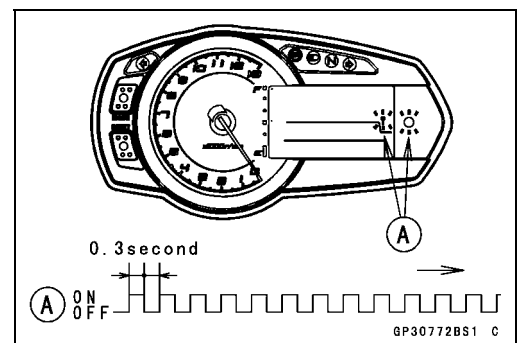

16-98 ELECTRICAL SYSTEM

Immobilizer System (Equipped Models)

- The first ignition key is successfully registered in the ECU.
- The warning indicator light (LED) and the immobilizer warning symbol [A] blink 1 time and stops for 1 second and the repeats this cycle to indicate successful registration of the first ignition key.

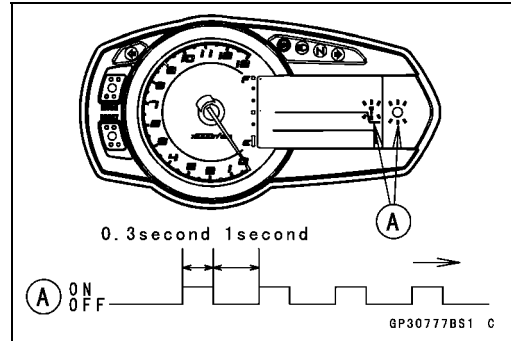

- Turn to OFF the ignition switch and remove the first ignition key.
- The immobilizer warning symbol [B] disappears.
- The warning indicator light (LED) [A] then blinks for 15 seconds; it means the ECU is in the registration mode.
- After 15 seconds, the ECU ends the registration mode and stops blinking the warning indicator light (LED).

NOTE

- Insert and turn on the next key between 15 seconds that the ECU is in the registration mode.
 - When a registration mode was ended, do the registered ignition key verification procedure over again to restart it. This applies to all ignition key registration.
- Insert the second ignition key into the ignition switch, and turn it to ON.

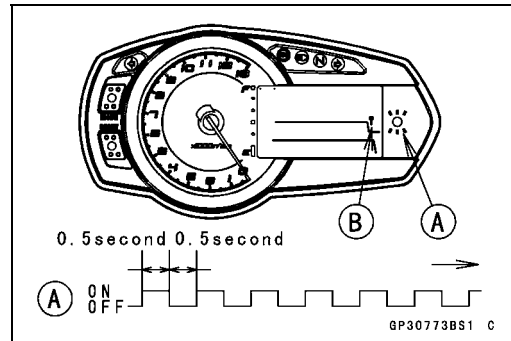

NOTE

- Keep other ignition keys away from the immobilizer antenna.
- If there is any problem in the registration, the warning indicator light (LED) and the immobilizer warning symbol [A] blink to display the collation error.
Immobilizer Amplifier Failure

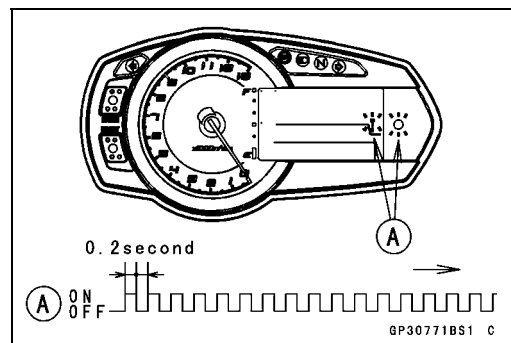

When Registered Ignition Key is Inserted.

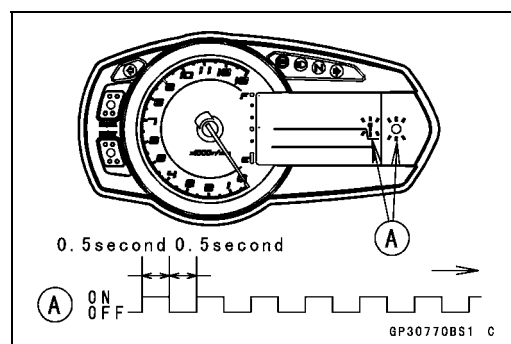

Immobilizer System (Equipped Models)

Ignition Key Collation Error

- The second ignition key is registered in the ECU.
 - The warning indicator light (LED) and the immobilizer warning symbol [A] blinks 2 times and stops for 1 second and repeats this cycle to indicate successful registration of the second ignition key.
 - Turn to OFF the ignition switch and wait for period more than 15 seconds.
 - The registration mode automatically ends.
-
- The warning indicator light (LED) [A] goes off.

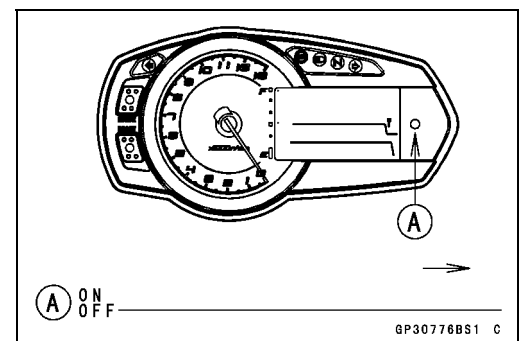
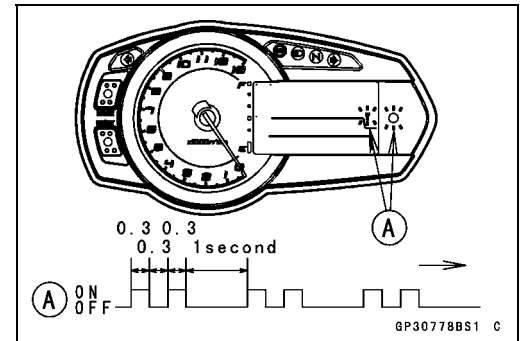
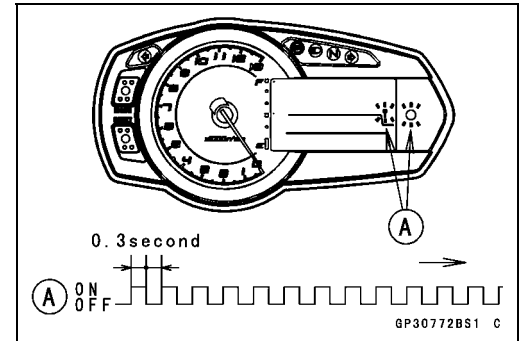

NOTE

- Turn the ignition switch ON with the registered ignition key.
- Check that the engine can be started using all registered ignition keys.

16-100 ELECTRICAL SYSTEM

Immobilizer System (Equipped Models)

All Keys Initial Registration Flow Chart

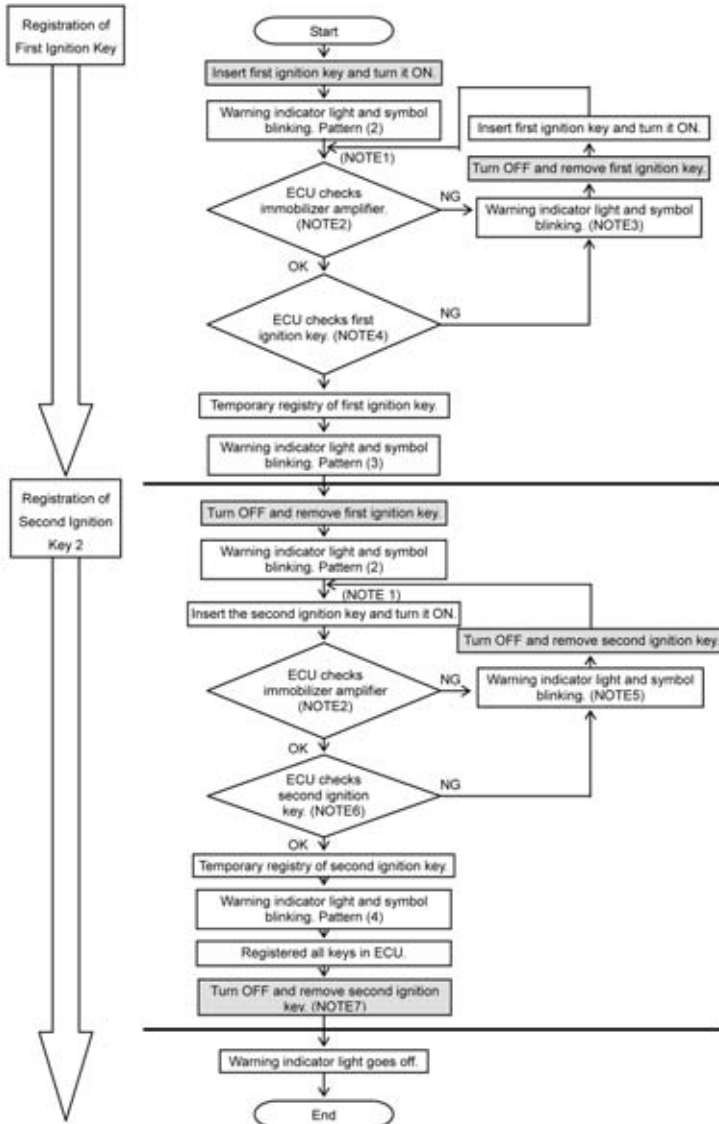

---Key registry action

Blinking Patterns and Number

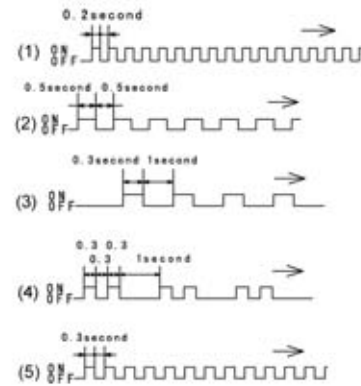

NOTE

1. Key Substitute Time
Insert next key and turn ON within 15 seconds after previous key is turned OFF.
2. ECU confirms the following
 - Power Supply of Amplifier
 - Connection of Amplifier
 - Time of Transmitting and Receiving Messages.
3. ECU confirms the following
 - Immobilizer Amplifier Failure Pattern (1)
 - Ignition Key Collision Error Pattern (5)
4. ECU confirms the following
 - Ignition Key or Not
 - Match the Unique Code
5. ECU confirms the following
 - Immobilizer Amplifier Failure Pattern (1)
 - Second Ignition Key Collision Error Pattern (5)
 - Registered Ignition Key is Inserted Pattern (2)
6. ECU confirms the following
 - Ignition Key or Not.
 - Match the Unique Code
 - Not Registered Ignition Key
7. When the ECU-registered key is turned "OFF", ECU keeps the power "ON" for two seconds. And then, in two seconds after the key is "OFF", ECU turns the power "OFF".

Immobilizer System (Equipped Models)

Immobilizer System Parts Replacement

Ignition Switch (Immobilizer Antenna) Replacement

- Remove:
 - Fuel Tank (see Fuel Tank Removal in the Fuel System (DFI) chapter)
 - Handlebar Holder (see Handlebar Removal in the Steering chapter)
 - Left Lower Fairing (see Lower Fairing Removal in the Frame chapter)
- Disconnect the lead connectors [A].
- Remove the steering stem (see Stem, Stem Bearing Removal in the Steering chapter).
- Using a small chisel or punch [A], turn out the Torx bolts.
- Remove the ignition switch [B].

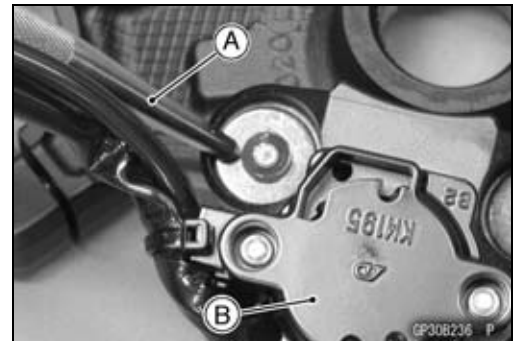
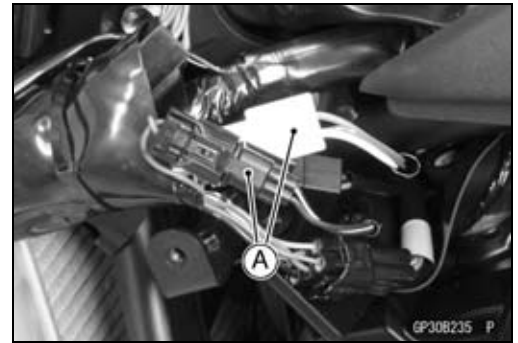

- Tighten a new Torx bolt [A] until the bolt head [B] is broken [C].
- Run the leads correctly (see Cable, Wire, and Hose Routing section in the Appendix chapter).

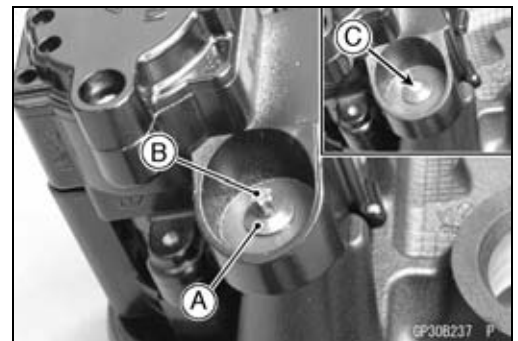

Immobilizer Amplifier Replacement

- Remove:
 - Left Center Fairing (see Center Fairing Removal in the Frame chapter)
 - Immobilizer Amplifier connector [A]
 - Immobilizer Amplifier [B]

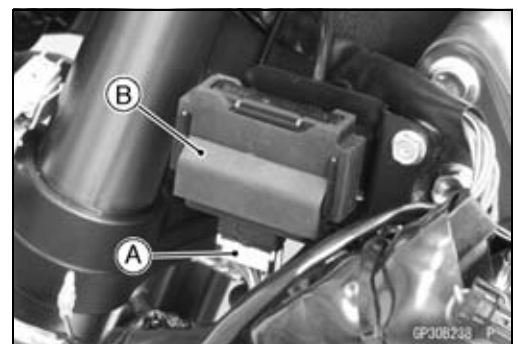

- Fit the slits [A] on the damper to the bracket projections [B].

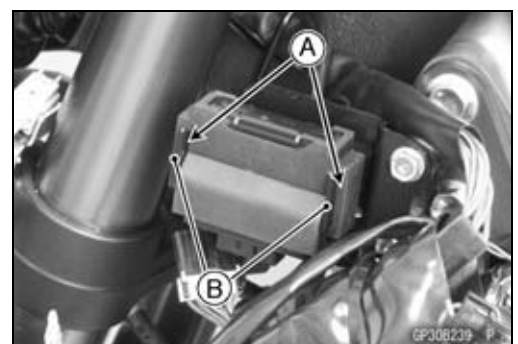

16-102 ELECTRICAL SYSTEM

Immobilizer System (Equipped Models)

ECU (Electronic Control Unit) Replacement (for Immobilizer Models)

NOTICE

Never drop the ECU, especially on a hard surface. Such a shock to the ECU can damage it.

- Remove:
 - Front Seat (see Front Seat Removal in the Frame chapter)
- Using a small chisel or other suitable tool, remove the screws [A] and ECU guard [B].
- Remove:
 - Relay Box (see Relay Box Removal)
 - ECU Connectors [A]
 - ECU [B]

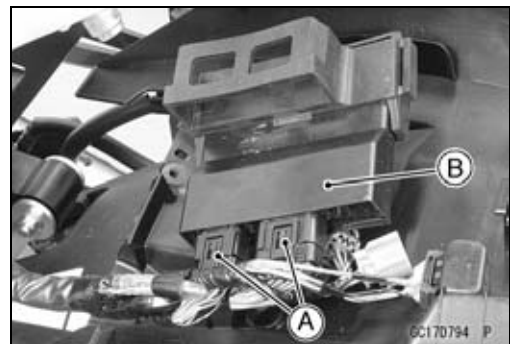
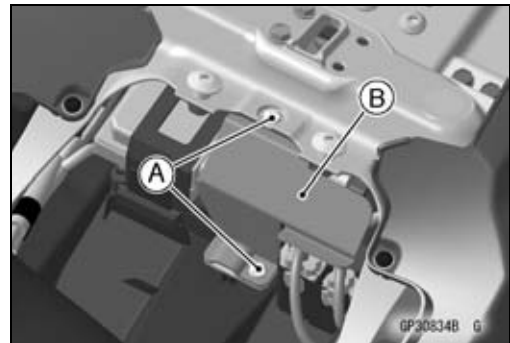

- Connect the connectors to the ECU.
- Install the ECU guard [A].

NOTICE

Do not pinch the leads.

- Tighten the new screws [B] using the Kawasaki genuine screws of which threads are coated with locking agent.

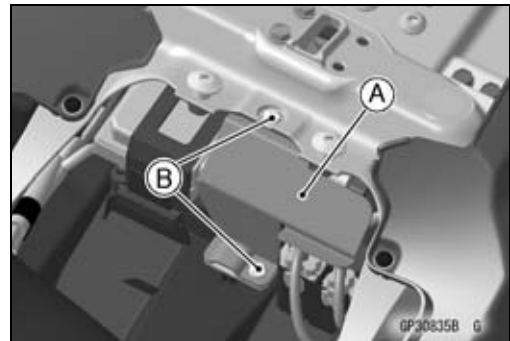

Immobilizer Relational Parts Replacement Chart

		Failed or Lost Part			
		Ignition Key (Black)	Ignition Switch	Amplifier	ECU
*	Ignition Key (Black)	●	○		
	Ignition Switch		●		
	Amplifier			●	
	ECU	○			●

*	Replacement Part
●	Main Replacement Part
○	Additional Replacement Part

Immobilizer System Inspection

- Refer to the Immobilizer Amplifier and Blank Key Detection section in the Fuel System (DFI) chapter.

Immobilizer System (Equipped Models)

Immobilizer System Circuit

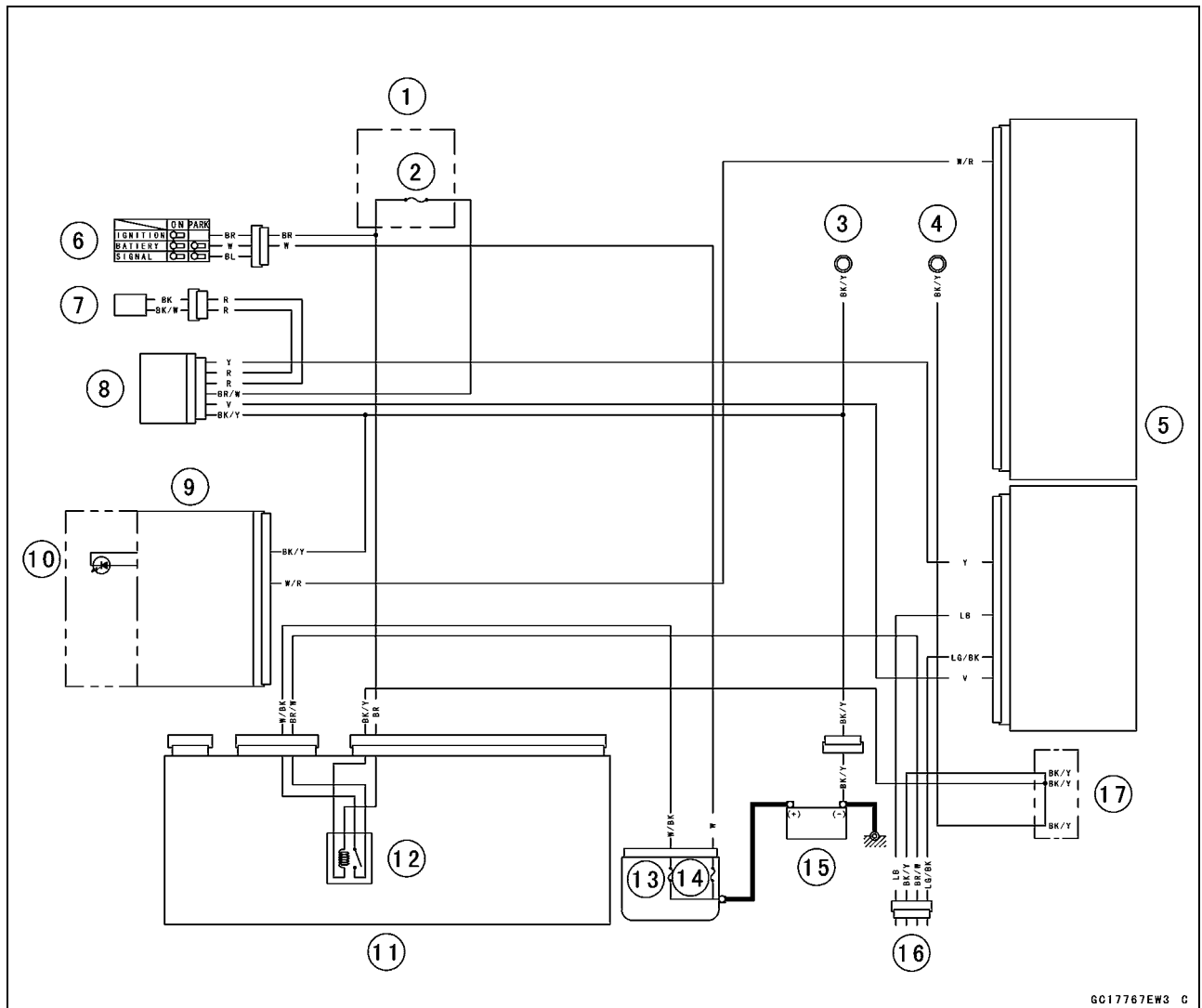

GC17767EW3 C

1. Fuse Box 2
2. Ignition Fuse 15 A
3. Meter Ground
4. Frame Ground
5. ECU
6. Ignition Switch
7. Immobilizer Antenna
8. Immobilizer Amplifier
9. Meter Unit
10. Water Temperature/Oil Pressure/FI/Immobilizer Warning Indicator Light (LED)
11. Relay Box
12. ECU Main Relay
13. FI Fuse 15 A
14. Main Fuse 30 A
15. Battery 12 V 8 Ah
16. Immobilizer/Kawasaki Diagnostic System Connector
17. Water-proof Joint C

16-104 ELECTRICAL SYSTEM

Switches and Sensors

Brake Light Timing Inspection

- Refer to the Brake Light Switch Operation Inspection in the Periodic Maintenance chapter.

Brake Light Timing Adjustment

- Refer to the Brake Light Switch Operation Inspection in the Periodic Maintenance chapter.

Switch Inspection

- Using a hand tester, check to see that only the connections shown in the table have continuity (about zero ohms).
- For the switch housings and the ignition switch, refer to the tables in the Wiring Diagram.
- ★ If the switch has an open or short, repair it or replace it with a new one.

Special Tool - Hand Tester: 57001-1394

Rear Brake Light Switch Connections

Rear Brake Light Switch Connections		
Color	BR	BL
When brake pedal is pushed down	○ — ○	○ — ○
When brake pedal is released		

Sidestand Switch Connections

Sidestand Switch Connections		
Color	BK	G
When sidestand is down		
When sidestand is up	○ — ○	○ — ○

Neutral Switch Connections

Neutral Switch Connections		
Color	SW. Terminal	Ground
When transmission is in neutral	○ — ○	○ — ○
When transmission is not in neutral		

Oil Pressure Switch Connections*

Oil Pressure Switch Connections *		
Color	SW. Terminal	Ground
When engine is stopped	○ — ○	○ — ○
When engine is running		

*: Engine lubrication system is in good condition.

Switches and Sensors

Water Temperature Sensor Inspection

- Remove the water temperature sensor (see Water Temperature Sensor Removal/Installation in the Fuel System (DFI) chapter).
- Suspend the sensor [A] in a container of coolant so that the threaded portion is submerged.
- Suspend an accurate thermometer [B] with temperature sensing portions [C] located in almost the same depth.

NOTE

- The sensor and thermometer must not touch the container side or bottom.
- Place the container over a source of heat and gradually raise the temperature of the coolant while stirring the coolant gently.
- Using the hand tester, measure the internal resistance of the sensor.
- The sensor sends electric signals to the ECU and coolant temperature gauge in the meter unit.
- Measure the resistance across the terminals and the body (for the gauge) at the temperatures shown in the table.
- ★ If the hand tester does not show the specified values, replace the sensor.

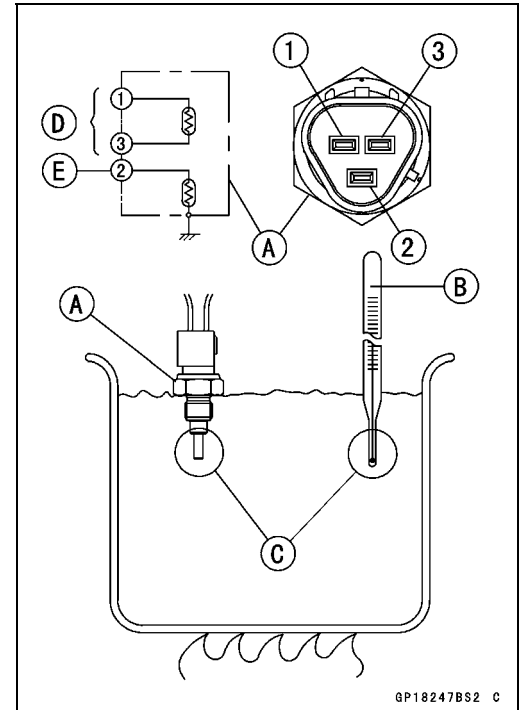

GP18247BS2 C

Water Temperature Sensor

Resistance for ECU [D]	
Temperature	Resistance (kΩ) (Terminal [1]-[3])
20°C (68°F)	2.46 + 0.155 - 0.143
80°C (176°F)	0.32 ±0.011
110°C (230°F)	0.1426 ±0.0041

Resistance for Water Temperature Gauge [E]	
Temperature	Resistance (Ω) (Terminal [2]-Body)
50°C (122°F)	210 ±40
120°C (248°F)	21.2 ±1.5

Speed Sensor Removal

NOTICE

Never drop the sensor especially on a hard surface. Such a shock to the sensor can damage it.

- Support the fuel tank with suitable bar (see Fuel Tank Removal in the Fuel System (DFI) chapter).
- Remove:
 - Speed Sensor Connector (Disconnect) [A]
 - Engine Sprocket Cover (see Engine sprocket Cover Removal in the Final Drive chapter)
 - Speed Sensor

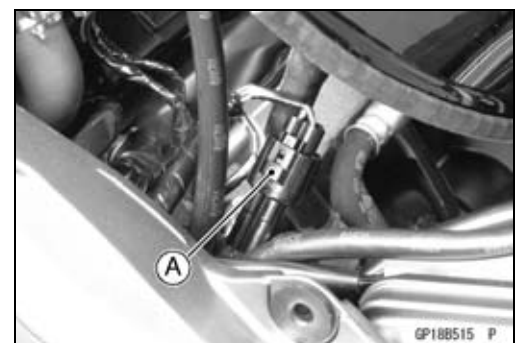

GP18B515 P

16-106 ELECTRICAL SYSTEM

Switches and Sensors

Speed Sensor Installation

- Apply a non-permanent locking agent to the speed sensor mounting bolt [A].
- Install the speed sensor [B] to the inner engine sprocket cover.
- Tighten:
Torque - Speed Sensor Mounting Bolt: 6.9 N·m (0.70 kgf·m, 61 in·lb)
- Install the engine sprocket cover (see Engine Sprocket Cover Installation in the Final Drive chapter).
- Connect the speed sensor lead connector.
- Install the fuel tank (see Fuel Tank Installation in the Fuel System (DFI) chapter).
- Confirm that the drain hose and clamp are installed securely and run the hose correctly (see Cable, Wire, and Hose Routing section in the Appendix chapter).

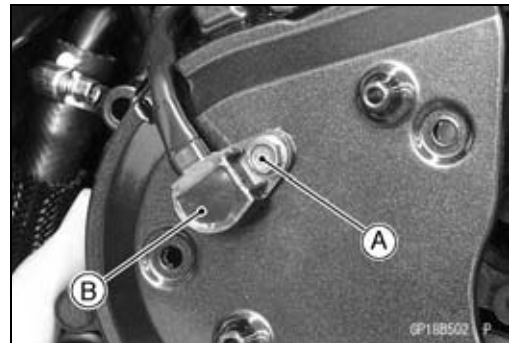

Speed Sensor Inspection

- Remove the speed sensor (see Speed Sensor Removal).
- Connect the speed sensor connector [A] with the battery [B], 10 kΩ resistor [C] and hand tester [D] as shown in the figure.
- Set the tester to the DC 25 V range.

Special Tool - Hand Tester: 57001-1394

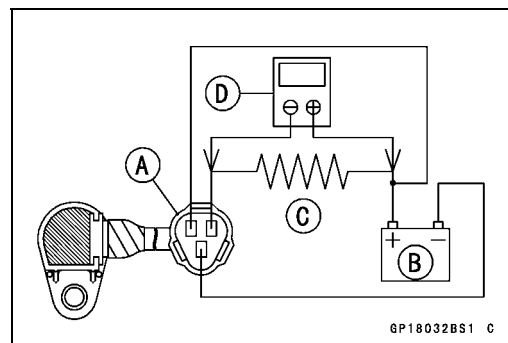

- Trace [A] of the speed sensor surface with the screwdriver.
- Then the tester indicator should flick [B].
- ★ If the tester indicator does not flick, replace the speed sensor.

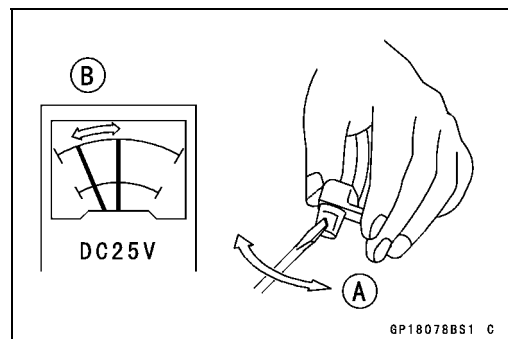

Oxygen Sensor Removal (Equipped Models)

NOTICE

Never drop the sensor especially on a hard surface. Such a shock to the sensor can damage it.

NOTICE

Do not pull strongly, twist, or bend the oxygen sensor lead. This may cause the wiring open.

- Clear the oxygen sensor lead from the clamp [A].
- Disconnect the oxygen sensor lead connector [B].

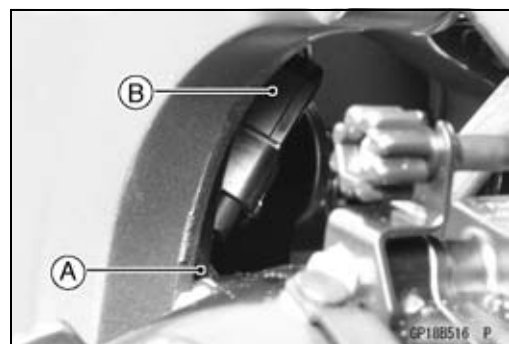

Switches and Sensors

- Clear the oxygen sensor lead from the clamp [A].
- Remove the oxygen sensor [B].

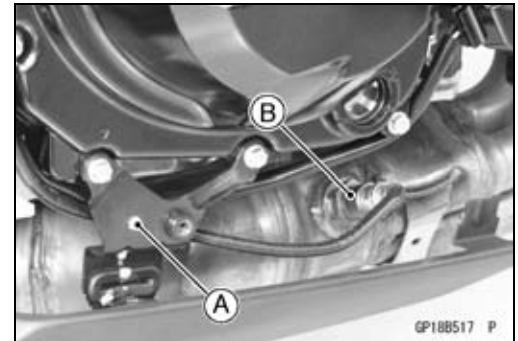

Oxygen Sensor Installation (Equipped Models)

NOTICE

Never drop the oxygen sensor [A] especially on a hard surface. Such a shock to the unit can damage it. Do not touch the sensing part [B] and filter holes [C] of the sensor to prevent oil contact. Oil contamination from hands can reduce sensor performance.

- Tighten:
 - Torque - Oxygen Sensor: 44 N·m (4.5 kgf·m, 32 ft·lb)
- Run the oxygen sensor lead correctly (see Cable, Wire, and Hose Routing section in the Appendix chapter).

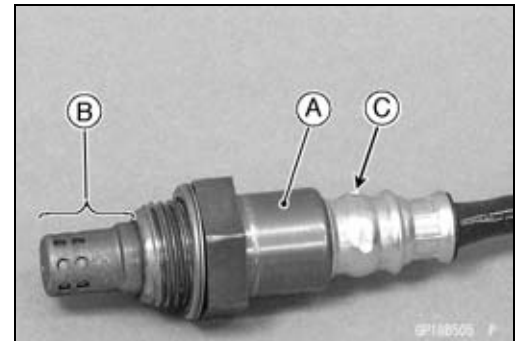

Oxygen Sensor Inspection (Equipped Models)

- Refer to the Oxygen Sensor Inspection in the Fuel System (DFI) chapter.

Fuel Level Sensor Inspection

- Remove:
 - Fuel Pump (see Fuel Pump Removal in the Fuel System (DFI) chapter)
- Check that the float moves up and down smoothly without binding. It should go down under its own weight.
- ★ If the float does not move smoothly, replace the fuel pump.
 - Float in Full Position [A]
 - Float in Empty Position [B]
 - Float Arm Stoppers [C]

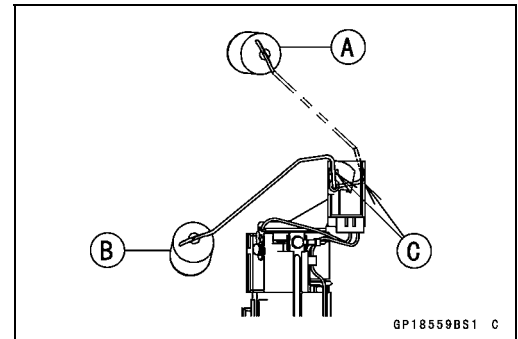

- Using the hand tester [A], measure the resistance across the terminals in the fuel level sensor lead connector [B].

Special Tools - Hand Tester: 57001-1394

Needle Adapter set: 57001-1457

- ★ If the tester readings are not as specified, or do not change smoothly according as the float moves up and down, replace the fuel pump.

Fuel Level Sensor Resistance

Standard: Full position: 9.6 ~ 12.4 Ω

Empty position: 222 ~ 228 Ω

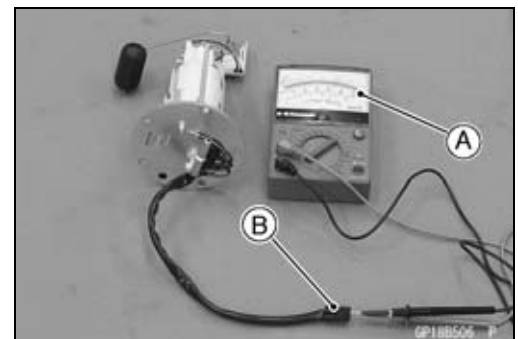

16-108 ELECTRICAL SYSTEM

Relay Box

The relay box [A] has relays and diodes. The relays and diodes can not be removed.



Relay Box Removal

NOTICE

**Never drop the relay box especially on a hard surface.
Such a shock to the relay box can damage it.**

- Remove the rear fender from the battery case and rear frame (see Flap and Rear Fender Removal in the Frame chapter).
- Disconnect:
Connectors [A]
- Remove:
Relay Box [B]

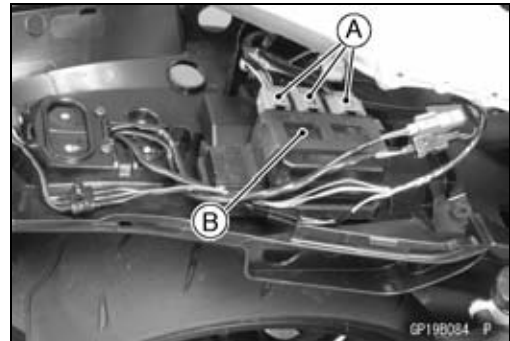

Relay Circuit Inspection

- Remove the relay box (see Relay Box Removal).
- Check conductivity of the following numbered terminals by connecting the hand tester and one 12 V battery to the relay box as shown (see Relay Box Internal Circuit in this section).
- ★ If the tester does not read as specified, replace the relay box.

Relay Circuit Inspection (with the battery disconnected)

	Tester Connection	Tester Reading (Ω)
Headlight Relay	1-3	∞
	7-6	∞
ECU Main Relay	4-5	Not ∞^*
	7-8	∞
Fuel Pump Relay	9-10	Not ∞^*
	11-16	∞
Starter Circuit Relay	11-12	∞
	17-20	∞
Fan Relay	18-19	Not ∞^*

*: The actual reading varies with the hand tester used.

Relay Box

Relay Circuit Inspection (with the battery connected)

	Battery Connection		Tester Connection	Tester Reading (Ω)
	(+)	(-)		
ECU Main Relay	2-11		1-3	0
	4-5		7-6	0
Fuel Pump Relay	9-10		7-8	0
Fan Relay	18-19		17-20	0

	Battery Connection		Tester Connection DC 25 V Range		Tester Reading (V)
	(+)	(-)	(+)	(-)	
Starter Circuit Relay	16-12		11-12		Battery Voltage

(+): Apply positive lead.

(-): Apply negative lead.

Diode Circuit Inspection

- Remove the relay box (see Relay Box Removal).
- Check conductivity of the following pairs of terminals (see Relay Box Internal Circuit in this section).

Diode Circuit Inspection

Tester Connection	1-11, 2-11, 12-13, 12-15, 12-16, 13-14, 13-15
-------------------	---

- ★ The resistance should be low in one direction and more than ten times as much in the other direction. If any diode shows low or high in both directions, the diode is defective and the relay box must be replaced.

NOTE

- *The actual meter reading varies with the meter or tester used and the individual diodes, but generally speaking, the lower reading should be from zero to one half the scale.*

16-110 ELECTRICAL SYSTEM

Relay Box

Relay Box Internal Circuit

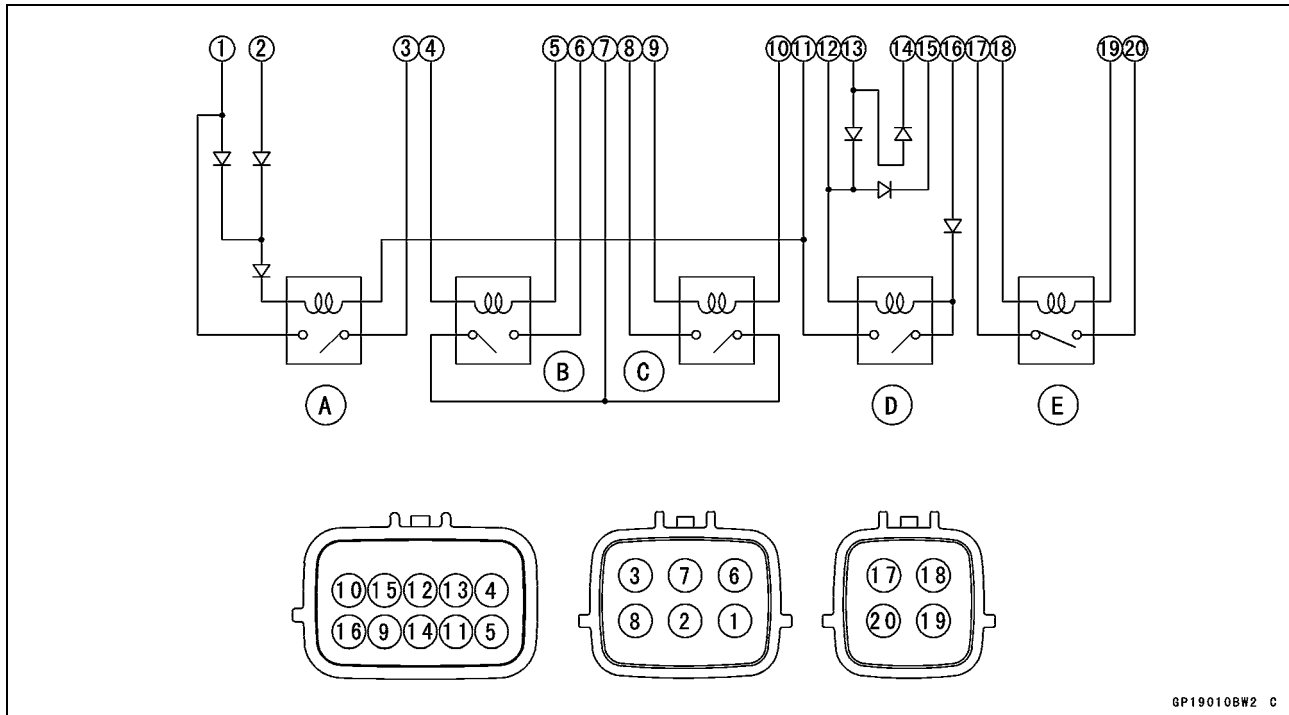

GP190108W2 C

- A: Headlight Relay
- B: ECU Main Relay
- C: Fuel Pump Relay
- D: Starter Circuit Relay
- E: Fan Relay

Fuse

30 A Main Fuse Removal

- Remove:
 - Starter Cable Terminal Cover (see Starter Relay Inspection)
- Pull out the main fuse [A] from the starter relay with a needle nose pliers.

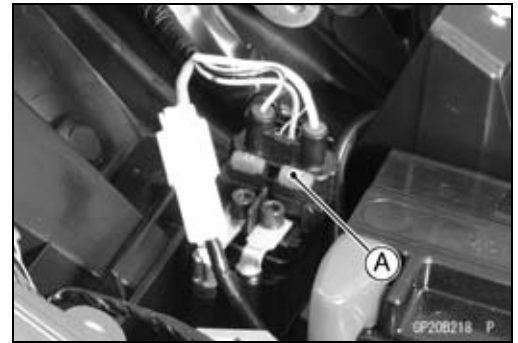

Fuse Box Fuse Removal

- Remove:
 - Front Seat (see Front Seat Removal in the Frame chapter)
- Unlock the hooks [A] to lift up the lids [B].

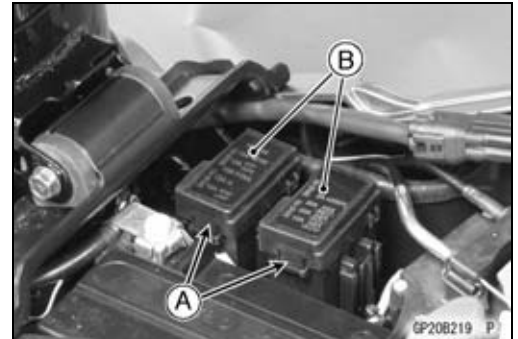

- Pull the fuses [A] straight out of the fuse box with needle nose pliers.

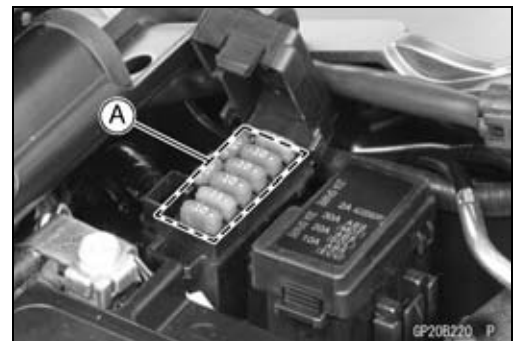

15 A FI Fuse Removal

- Remove:
 - Starter Cable Terminal Cover (see Starter Relay Inspection)
- Pull out the fuse [A].



Fuse Installation

- If a fuse fails during operation, inspect the electrical system to determine the cause, and then replace it with a new fuse of proper amperage.
- Install the fuse box fuses on the original position as specified on the lid.

16-112 ELECTRICAL SYSTEM

Fuse

Fuse Inspection

- Remove the fuse.
- Inspect the fuse element.
- ★ If it is blown out, replace the fuse. Before replacing a blown fuse, always check the amperage in the affected circuit. If the amperage is equal to or greater than the fuse rating, check the wiring and related components for a short circuit.

Housing [A]

Fuse Element [B]

Terminals [C]

Blown Element [D]

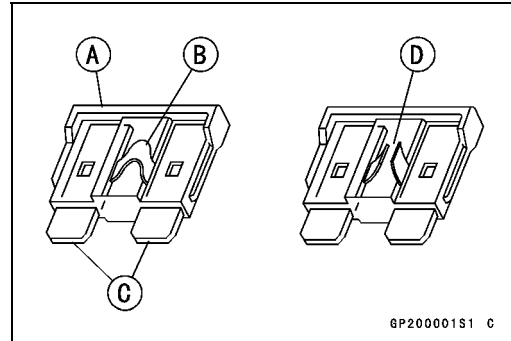

NOTICE

When replacing a fuse, be sure the new fuse matches the specified fuse rating for that circuit. Installation of a fuse with a higher rating may cause damage to wiring and components.

Appendix

Table of Contents

Cable, Wire, and Hose Routing	17-2
Troubleshooting Guide	17-76

17-2 APPENDIX

Cable, Wire, and Hose Routing

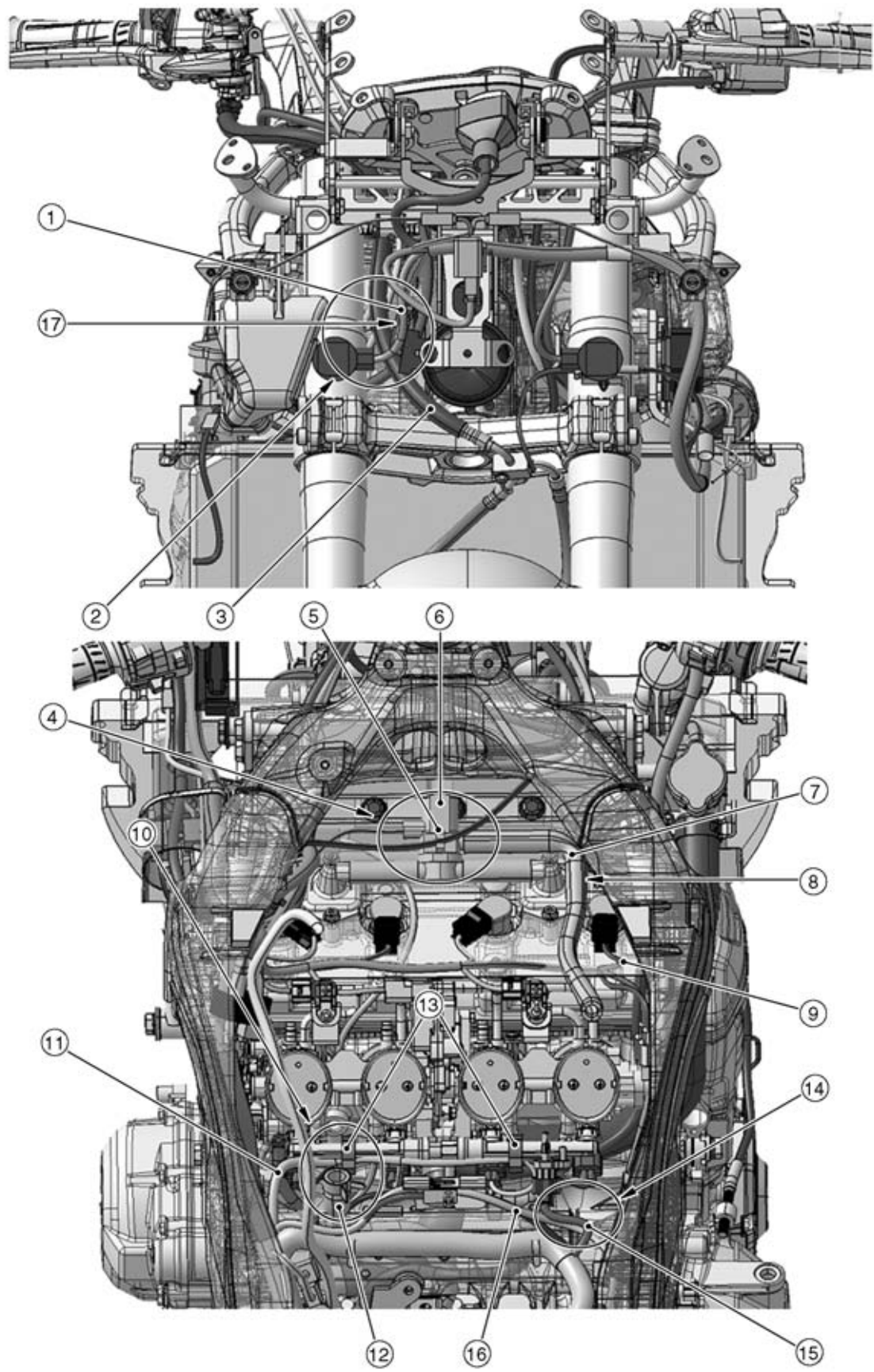

Cable, Wire, and Hose Routing

1. Headlight Lead
2. Run the brake hose to the rear side of the headlight lead.
3. Brake Hose
4. Run the front right turn signal light lead through the air switching valve. And run to the rear side of the light switch housing.
5. Air Switching Valve Clamp
6. Air Switching Valve
7. Air Switching Valve Hose
8. Run the air switching valve hose to the upside of the stick coil lead.
9. Stick Coil Lead
10. Run the injector lead to the front side of the breather hose.
11. Injector Lead
12. Breather Hose
13. Hold the injector lead with clamp
14. Run the intake air temperature sensor to the upside of the crankshaft sensor lead.
15. Intake Air Temperature Sensor Lead
16. Crankshaft Sensor Lead
17. Connect the horn lead connectors so that the horn lead comes upside.

17-4 APPENDIX

Cable, Wire, and Hose Routing

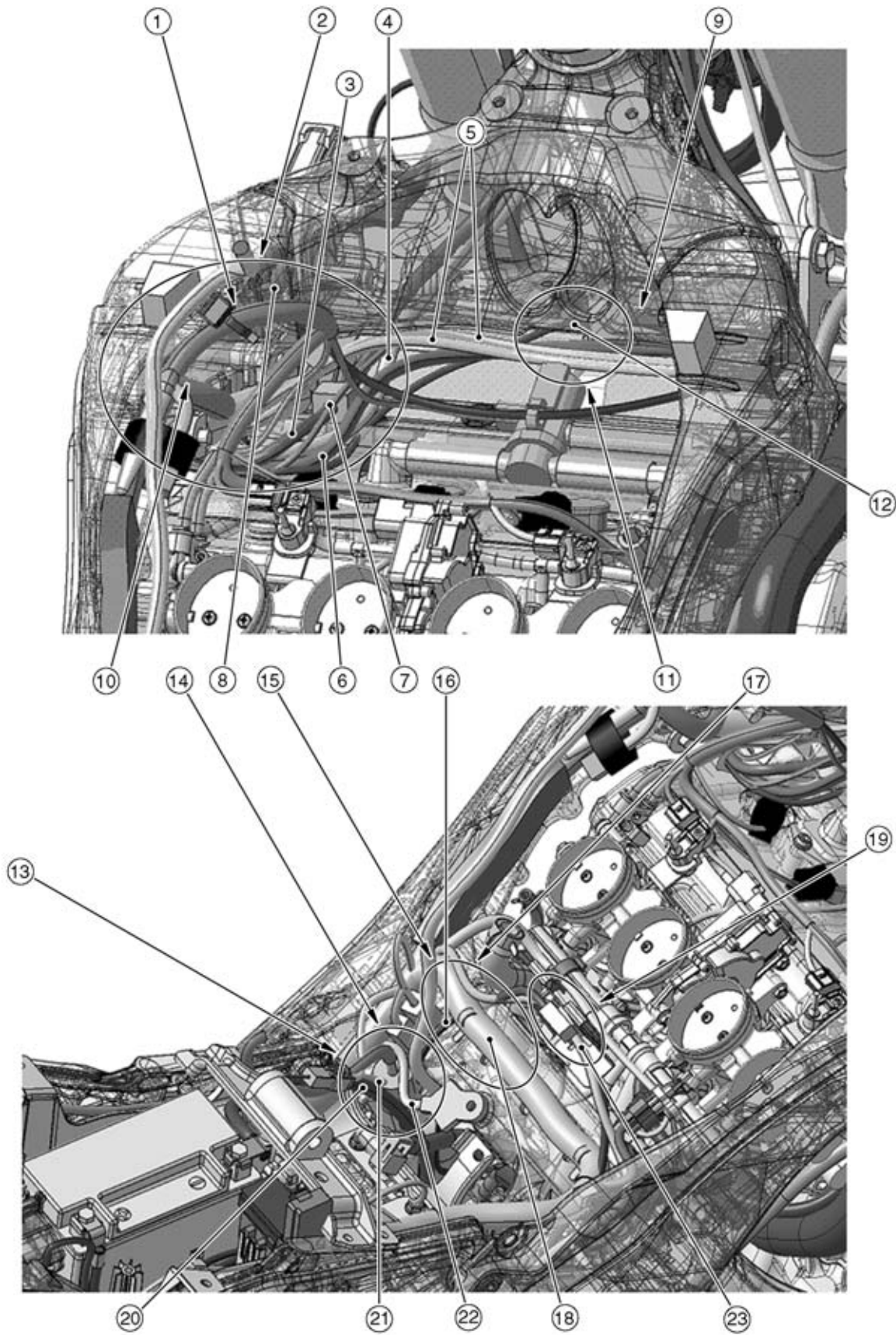

Cable, Wire, and Hose Routing

1. Insert the clamp on the main harness to the rib of the frame as shown.
2. Run the headlight lead, right and left light switch housing lead, ignition switch lead, immobilizer amplifier lead (equipped models) and radiator fan motor lead to the front side of engine mount bracket, right turn signal light lead and air switching valve, and run them under the throttle cable and outside of frame.
3. Left Switch Housing Lead
4. Ignition Switch Lead
5. Throttle Cables
6. Right Switch Housing Lead
7. Immobilizer Amplifier Lead
8. Headlight Lead
9. Run the clutch cable under the other lead and front side of radiator.
10. Run the main harness to the outside of the between engine mount bracket and frame.
11. Run the radiator fan motor lead, right switch housing and throttle cable in order from the frame.
12. Radiator Fan Motor Lead
13. Run the starter motor cable (+) to the upside of the battery negative (-) cable.
14. Run the frame ground lead to the front side of the starter motor cable and battery negative (-) cable.
15. Run the alternator lead to the under the main harness.
16. Alternator Lead
17. Run the alternator lead and crankshaft sensor lead to the rear side of breather hose.
18. Main Harness
19. Hold the alternator lead and crankshaft sensor lead with clamp.
20. Battery Negative (-) Cable
21. Starter Motor (+) Cable
22. Frame Ground Lead
23. Crankshaft Sensor Lead

17-6 APPENDIX

Cable, Wire, and Hose Routing

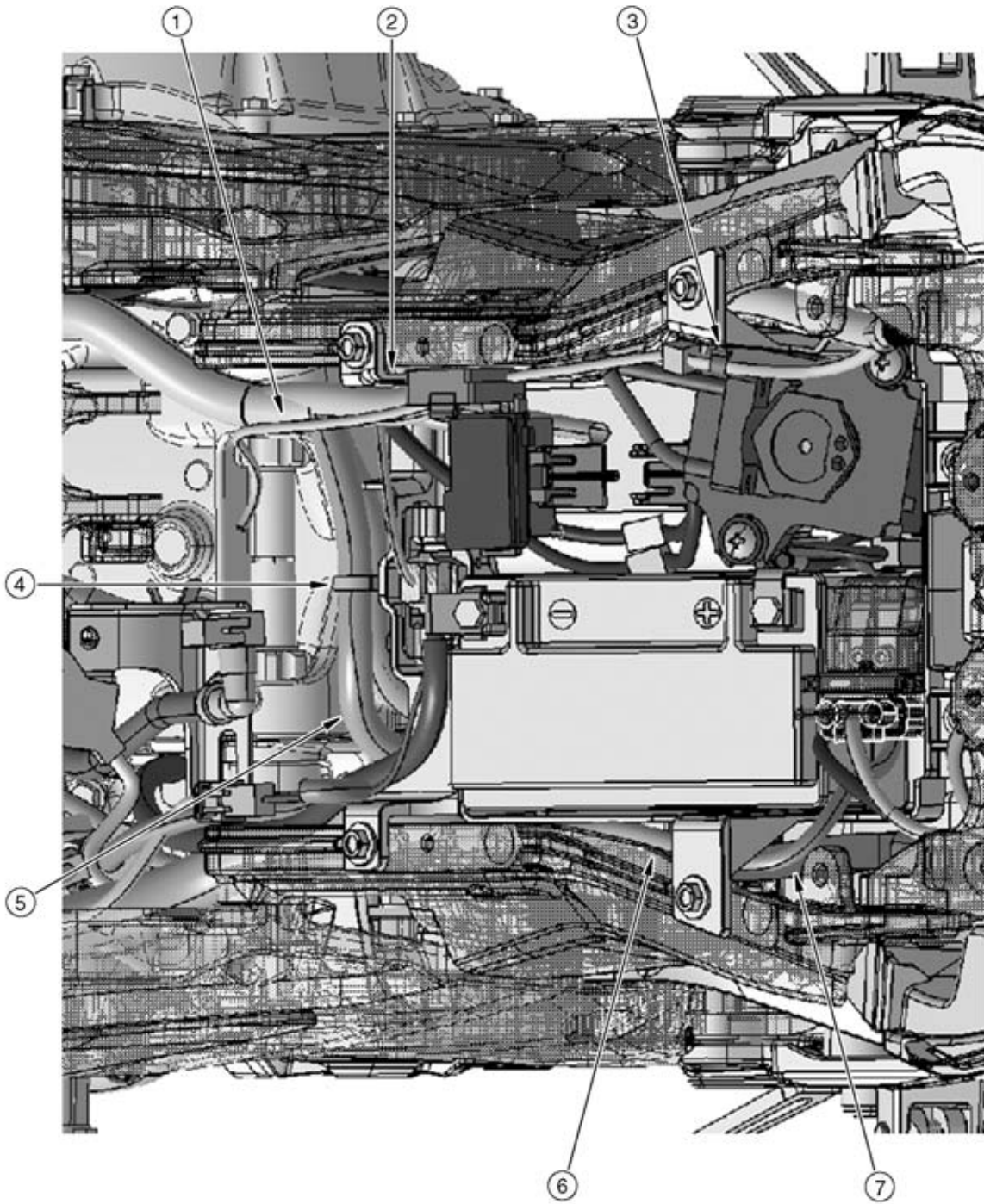

Cable, Wire, and Hose Routing

1. Run the fuel pump lead to the upside of the exhaust butterfly valve cables, to the outside of the fuse box, and to under the fuel tank bracket.
2. Run the rear of main harness to inside of the battery case, to underside of the fuel pump lead, to rear of the battery case mounting and to the outside of the battery case as shown.
3. Hold the fuel pump lead (main harness side) with the clamp.
4. Hold the main harness with the clamp.
5. Run the regulator/rectifier harness to the under the battery case.
6. Run the starter motor cable to the upside of the main harness.
7. Run the starter motor cable to between the main relay and battery, and to inside of the starter motor cable.

17-8 APPENDIX

Cable, Wire, and Hose Routing

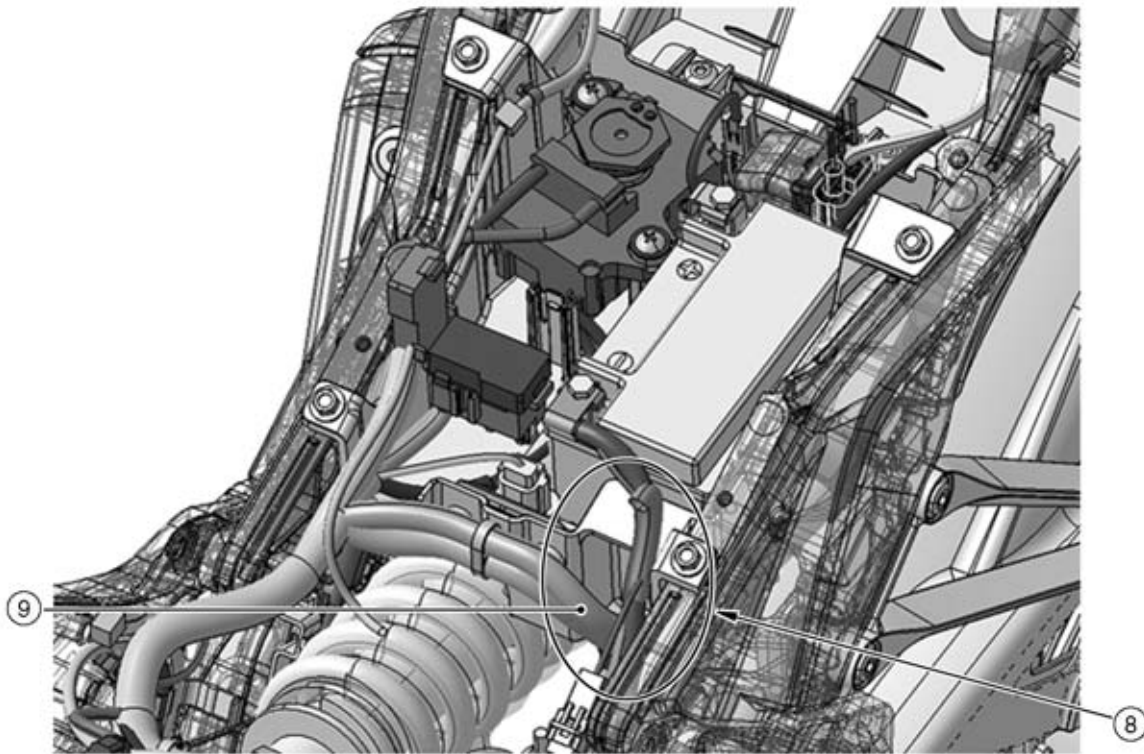
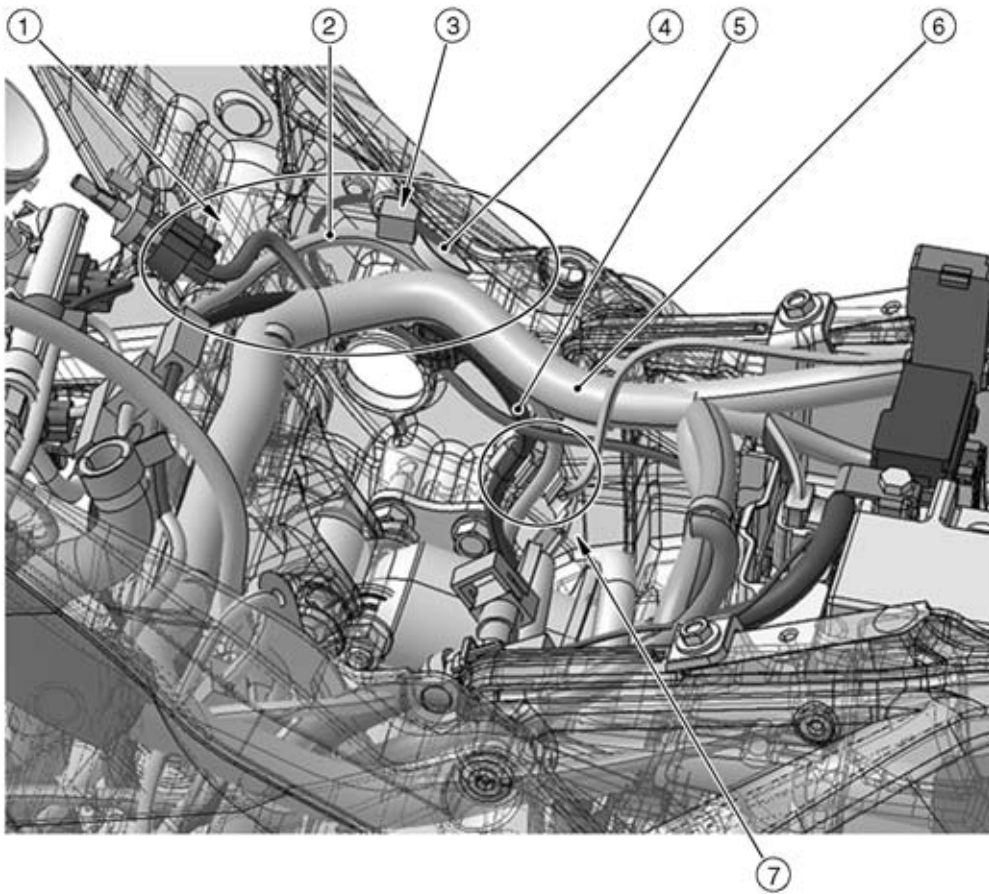

Cable, Wire, and Hose Routing

1. Run the oxygen sensor lead (equipped models), crankshaft sensor lead and rear brake light switch lead to the outside of main harness.
2. Crankshaft Sensor Lead
3. Hold the rear brake light switch connector with the clamp.
4. Rear Brake Light Switch Lead
5. Oxygen Sensor Lead
6. Main Harness
7. Insert the clamps to the ribs of the inside of the frame, hold the oxygen sensor lead and crankshaft sensor lead.
8. Run the regulator/rectifier harness from the cutout on the battery case to under side of the battery case.
9. Regulator/Rectifier Harness

17-10 APPENDIX

Cable, Wire, and Hose Routing

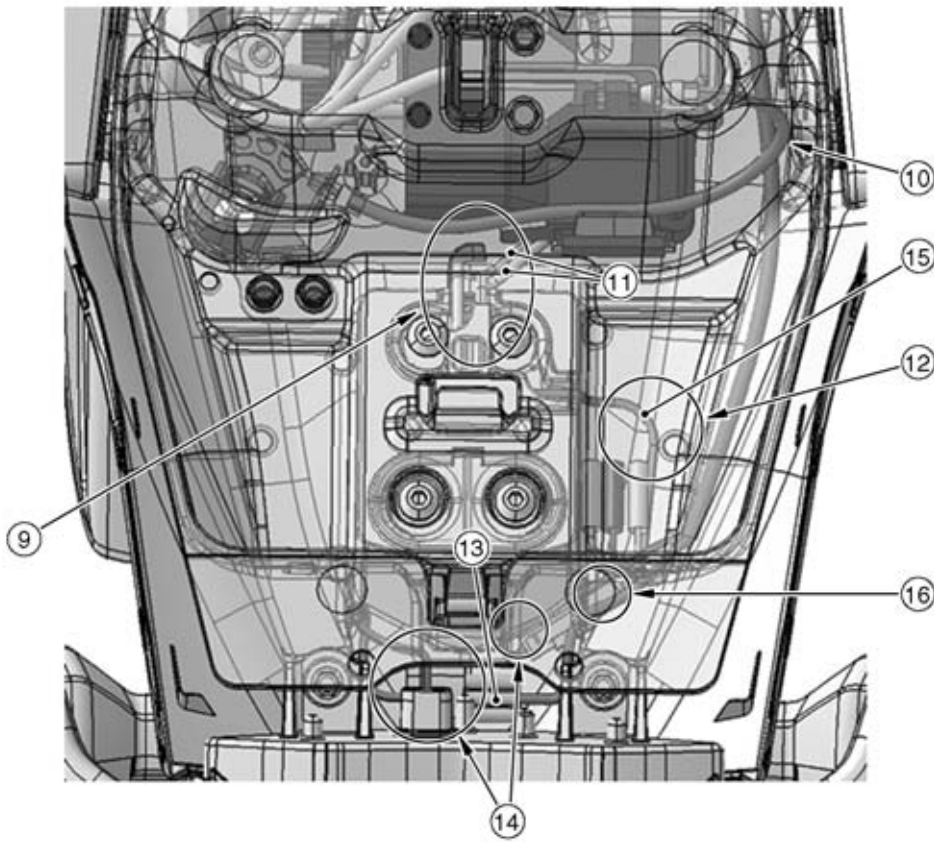
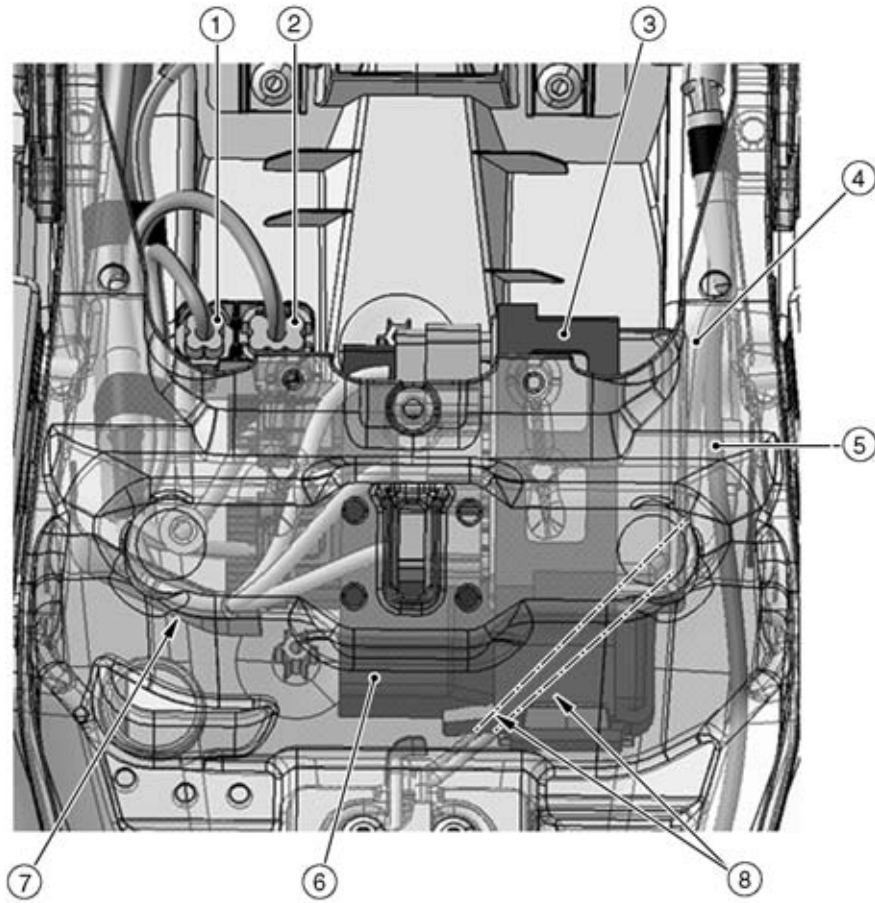

Cable, Wire, and Hose Routing

1. Kawasaki Diagnostic System Connector
2. ABS Self-diagnosis Connector (ABS Equipped Models)
3. Relay Box
4. Rear Left Turn Signal Light Lead
5. Rear Right Turn Signal Light Lead
6. ECU
7. Run the leads to forward of the rear fender wall connect them.
8. Run the turn signal light leads to the inside of ECU rib under the ECU and connect them.
9. Run the right and left turn signal light leads to forward of the rear frame wall and connect them.
10. Run the seat lock cable to front side of the frame wall and upside of the turn signal light lead and license plate light lead.
11. Rear Left and Right Turn Signal Light Lead
12. Run the license plate light lead to right side of the frame and connect them at position as shown.
13. Tail/Brake Light (LED) Lead
14. Run the licence plate light lead and tail/brake light (LED) lead reward to under of the rear frame after connected. Be careful not to pinch the leads with rear fender.
15. License Plate Light Lead
16. Run the licence plate light lead (main harness side) and tail/brake light (LED) lead (main harness side) reward to under of the rear flame (for prevention to pinch the leads with rear fender).

17-12 APPENDIX

Cable, Wire, and Hose Routing

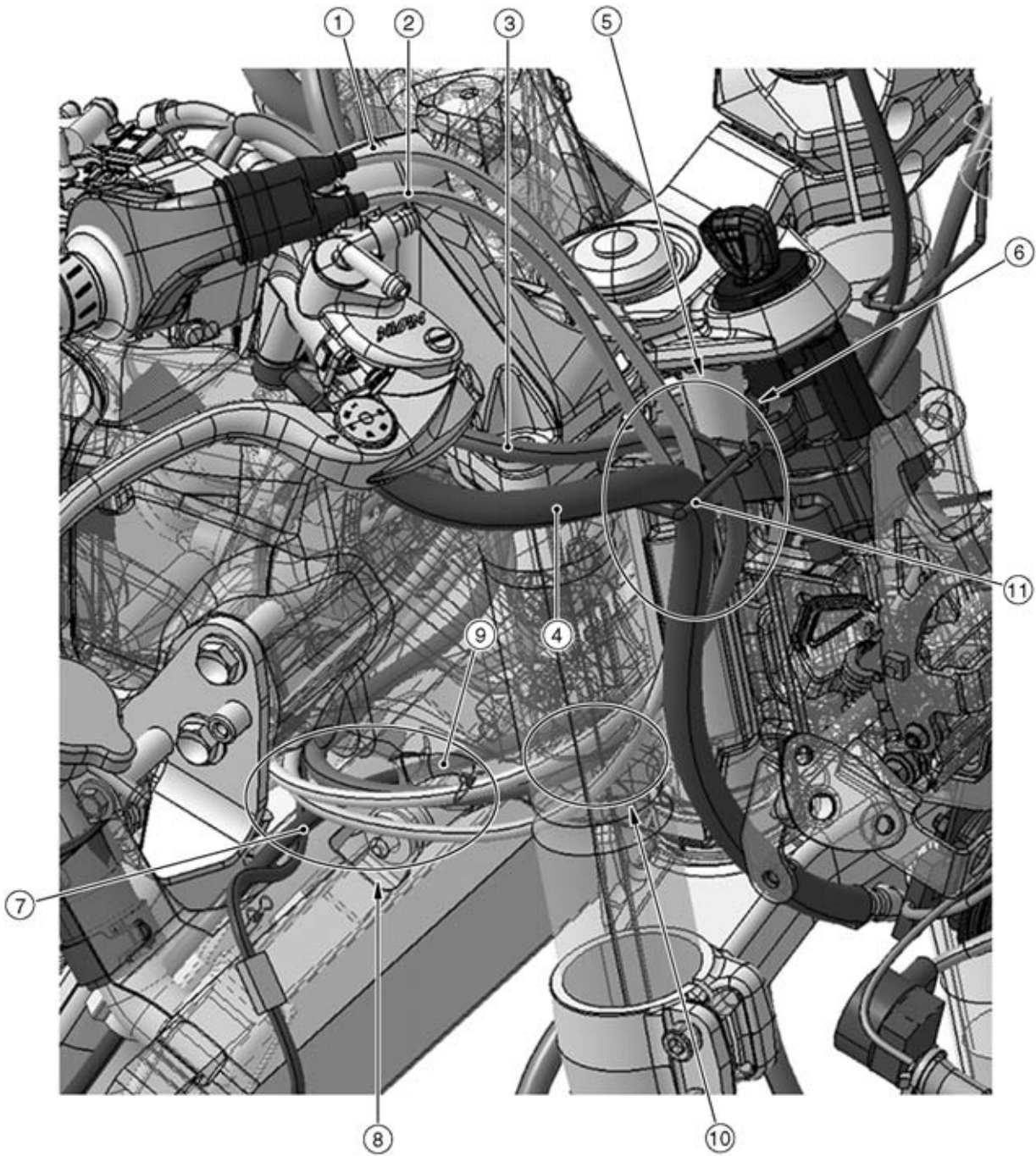

Cable, Wire, and Hose Routing

1. Throttle Cable (Accelerator)
2. Throttle Cable (Decelerator)
3. Right Switch Housing Lead
4. Brake Hose
5. Clamp the brake hose, throttle cable (decelerator), throttle cable (accelerator) and right switch housing lead in order from the outside of frame.
6. Run the brake hose comes to the most front side of the other lead. Run the right switch housing lead comes to the most rear side of the other lead.
7. Front Right Turn Signal Light Lead
8. Run the throttle cables, clutch cable, front turn signal light lead, right switch housing leads through this point to the inside of the frame.
9. Clutch Cable
10. Run the throttle cables and right switch housing leads through the inside of front fork.
11. Clamp

17-14 APPENDIX

Cable, Wire, and Hose Routing

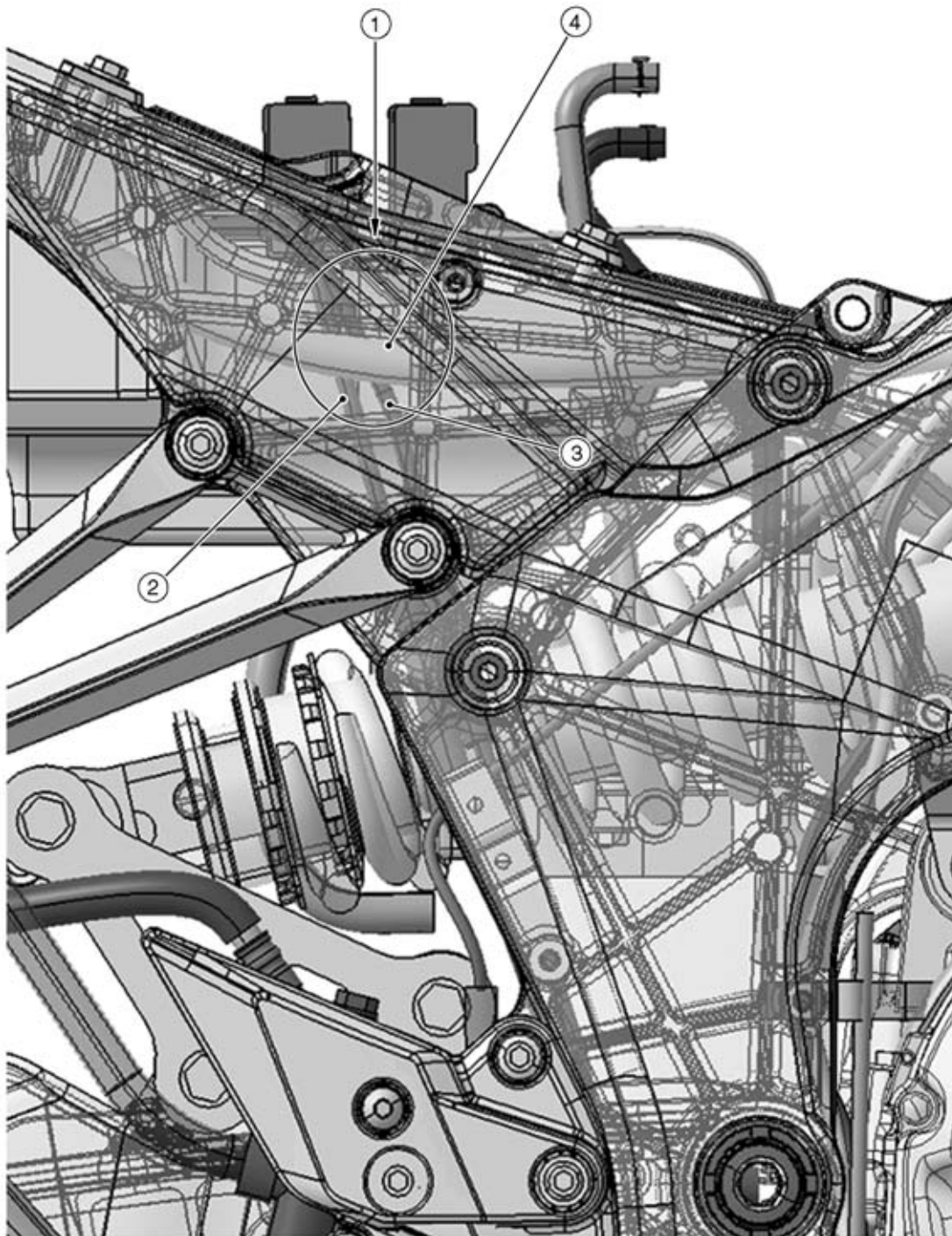

Cable, Wire, and Hose Routing

1. Run the exhaust butterfly valve cables to inside of the main harness.
2. Exhaust Butterfly Valve Close Cable
3. Exhaust Butterfly Valve Open Cable
4. Main Harness

17-16 APPENDIX

Cable, Wire, and Hose Routing

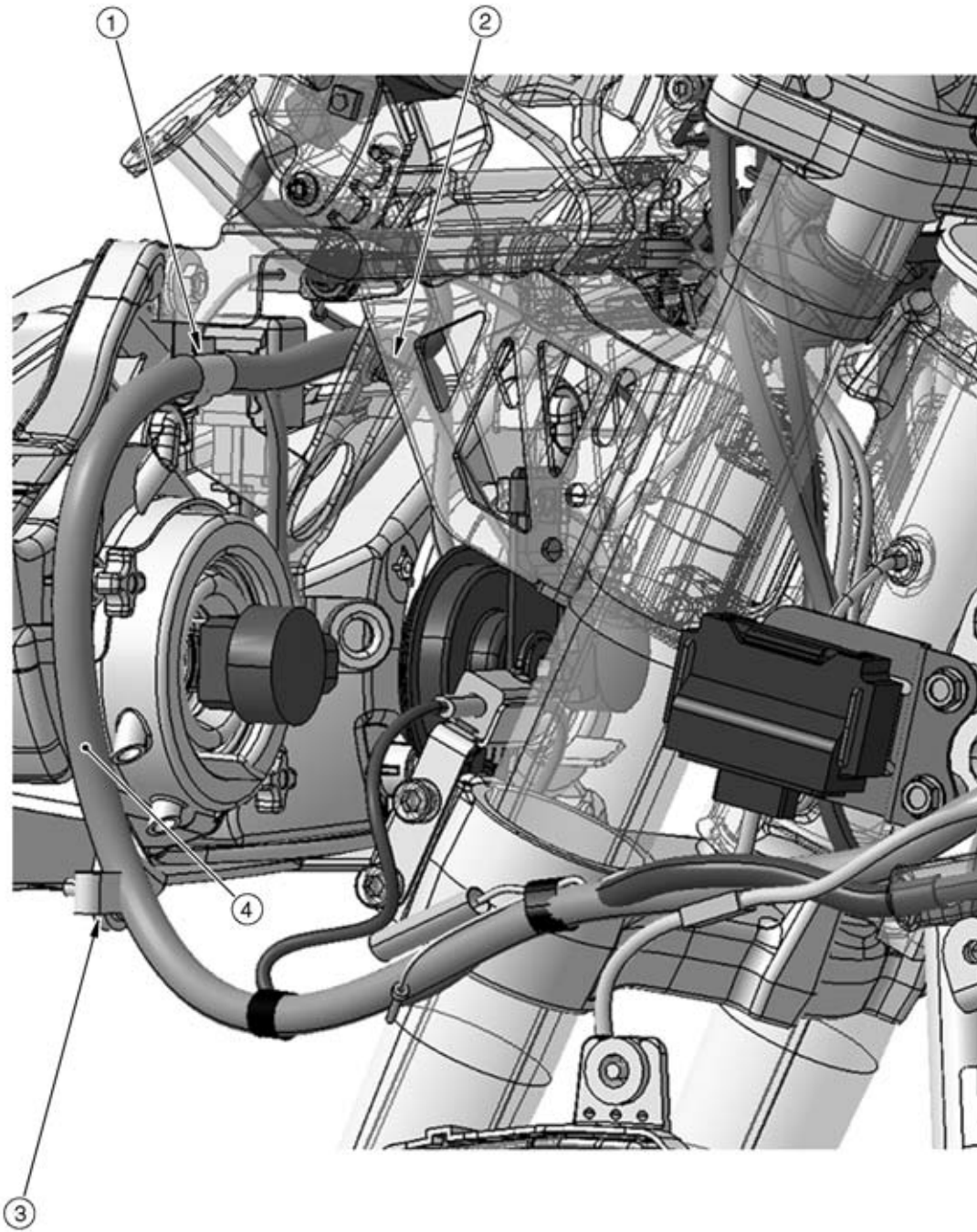

Cable, Wire, and Hose Routing

1. Bend the clamp upward to secure the harness at the portion of the taped.
2. Install the main harness clamp at the headlight bracket.
3. Bend the clamp reward to inside to secure the harness at the portion of the taped.
4. Main Harness

17-18 APPENDIX

Cable, Wire, and Hose Routing

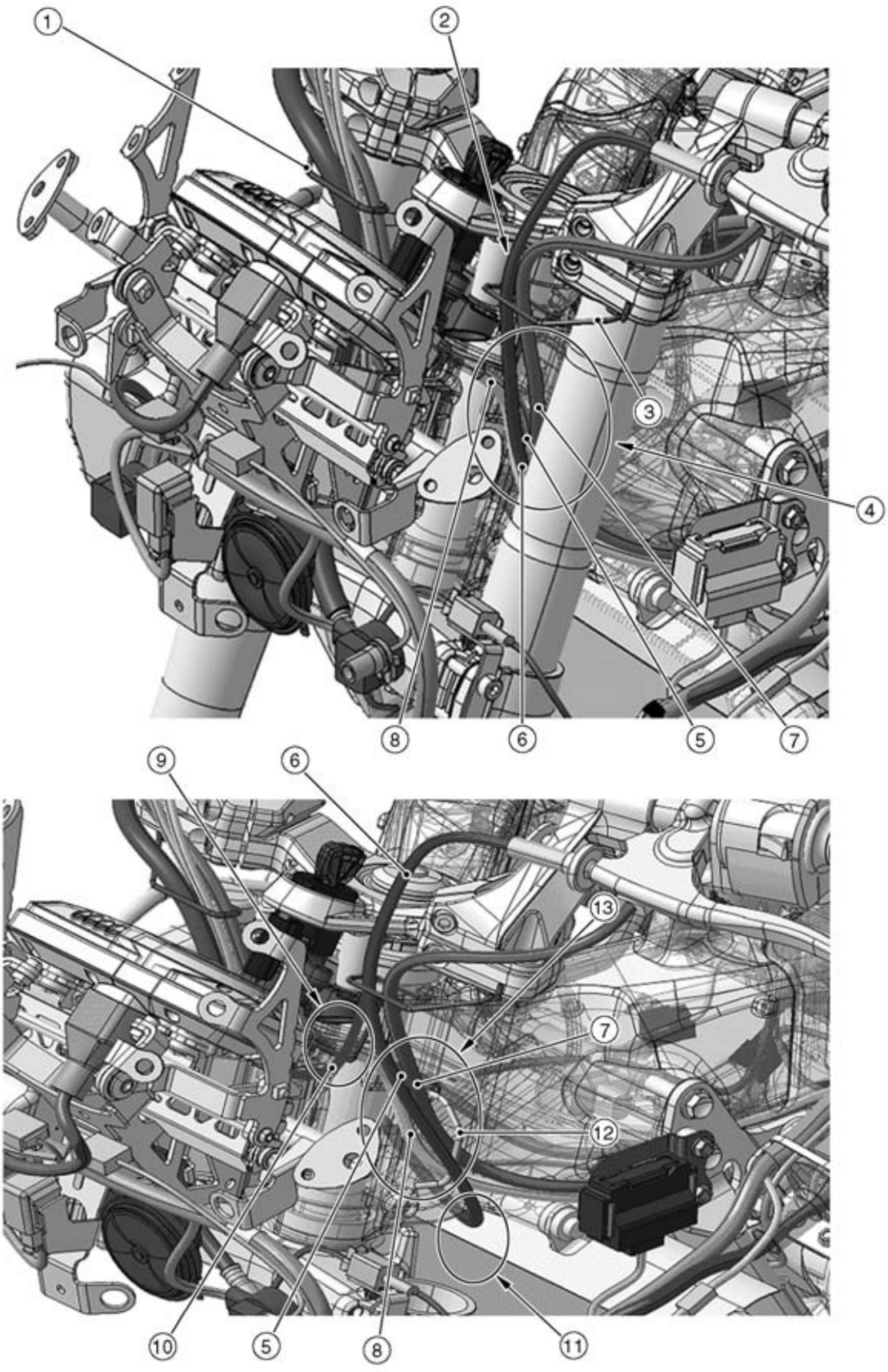

Cable, Wire, and Hose Routing

1. Clamp
2. Run the clutch cable and left switch housing lead in order from the inside of clamp.
3. Clamp
4. Run the left switch housing leads, ignition switch lead, immobilizer antenna lead (equipped models), and clutch cables to the inside of the front fork.
5. Immobilizer Antenna Lead
6. Clutch Cable
7. Left Switch Housing Lead
8. Ignition Switch Lead
9. Run the ignition switch lead and immobilizer antenna lead inside of clamp.
10. Clamp
11. Run the clutch cable outside through the lower side of the radiator mounting position, and to the under of the other leads.
12. Clamp
13. Run the ignition switch lead, immobilizer antenna lead and left switch housing lead to the inside of the clamp.

17-20 APPENDIX

Cable, Wire, and Hose Routing

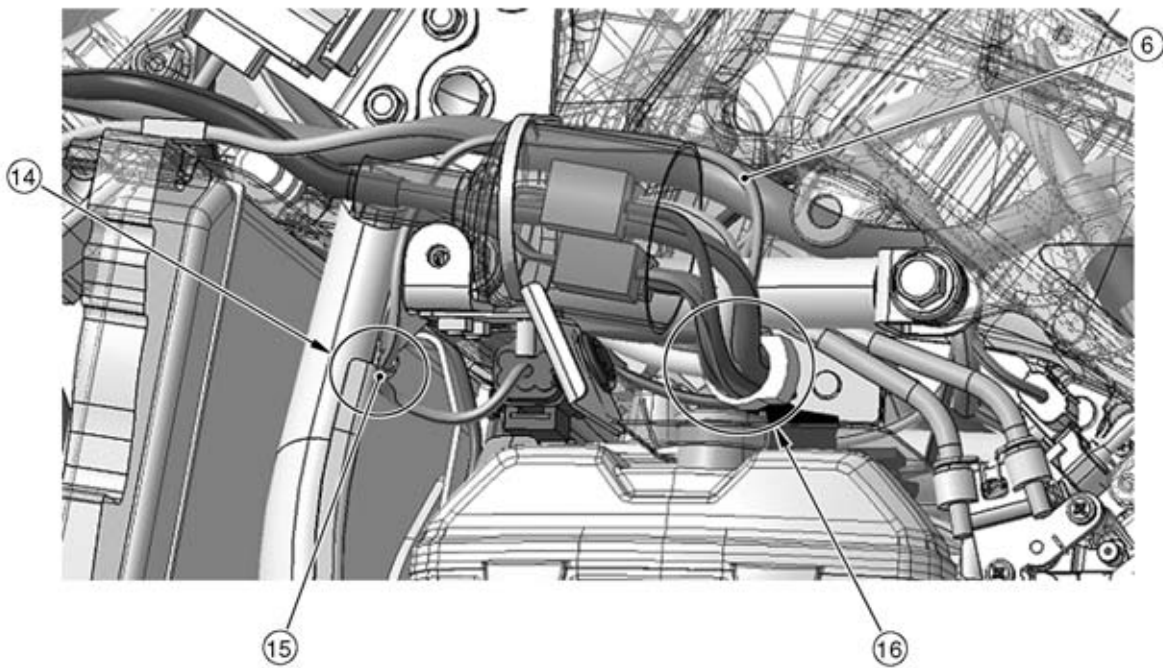
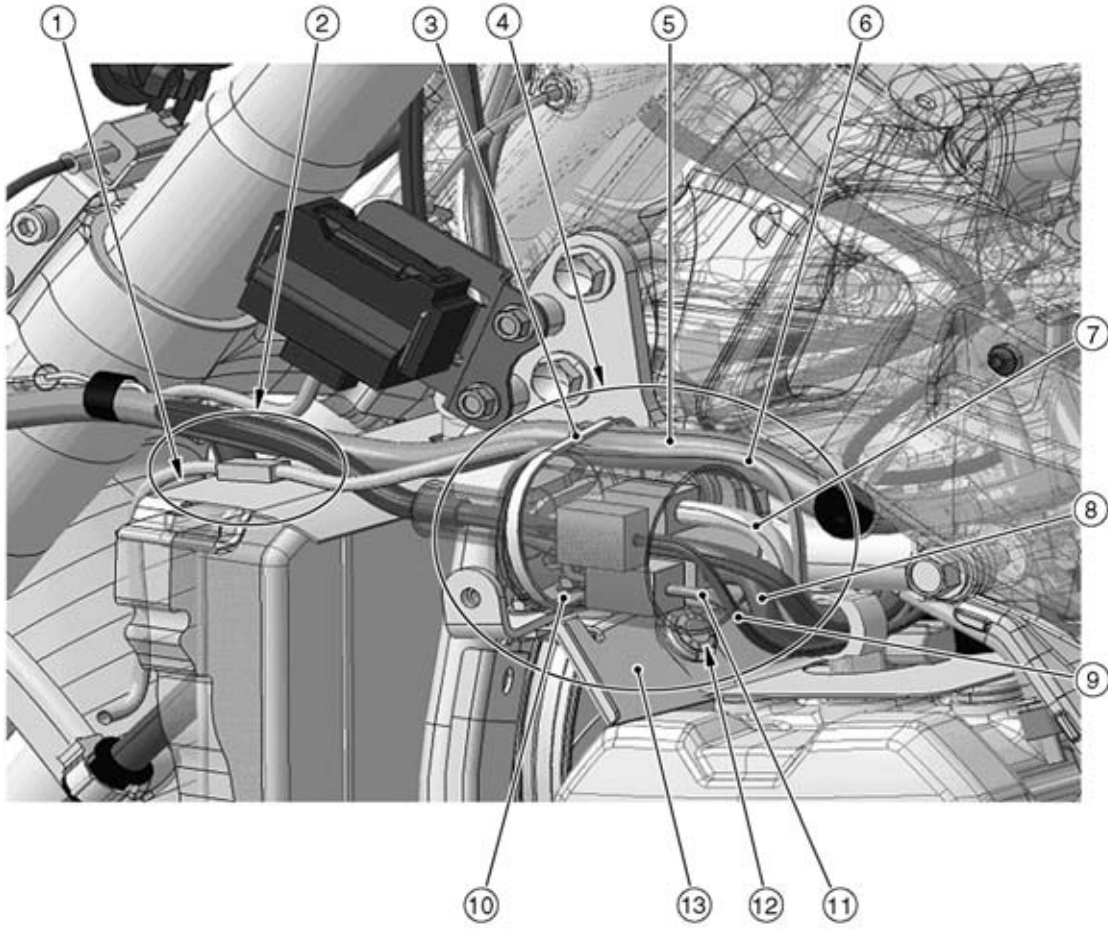

Cable, Wire, and Hose Routing

1. Insert the hole on the engine top heat protector into the slit on the radiator side pad.
2. Connect the left turn signal light lead at the rear of radiator side pad, and push its connector into the cutout on the pad.
3. Band
4. Cover the right switch housing lead, ignition switch lead, immobilizer antenna lead (equipped models) and radiator fan motor lead with the rubber cover, and tie the rubber cover and main harness and neutral switch/oil pressure switch with the band then secure them to the heat insulation plate. Cut the band excess length after tying them.
5. Main Harness
6. Neutral Switch/Oil Pressure Switch Lead
7. Ignition Switch Lead
8. Right Switch Housing Lead
9. Radiator Fan Motor Lead
10. Rubber Cover
11. Immobilizer Antenna Lead
12. Hold the engine top heat protector to the heat insulation plate with the rivets from the front side (the right side is same as the left side).
13. Heat Insulator
14. Run the neutral switch/oil pressure switch lead to inside of rubber cover and connect them. Then hold the neutral switch/oil pressure switch lead with clamp on the engine bracket.
15. Clamp
16. Hold the neutral switch/oil pressure switch lead with clamp on the bracket.

17-22 APPENDIX

Cable, Wire, and Hose Routing

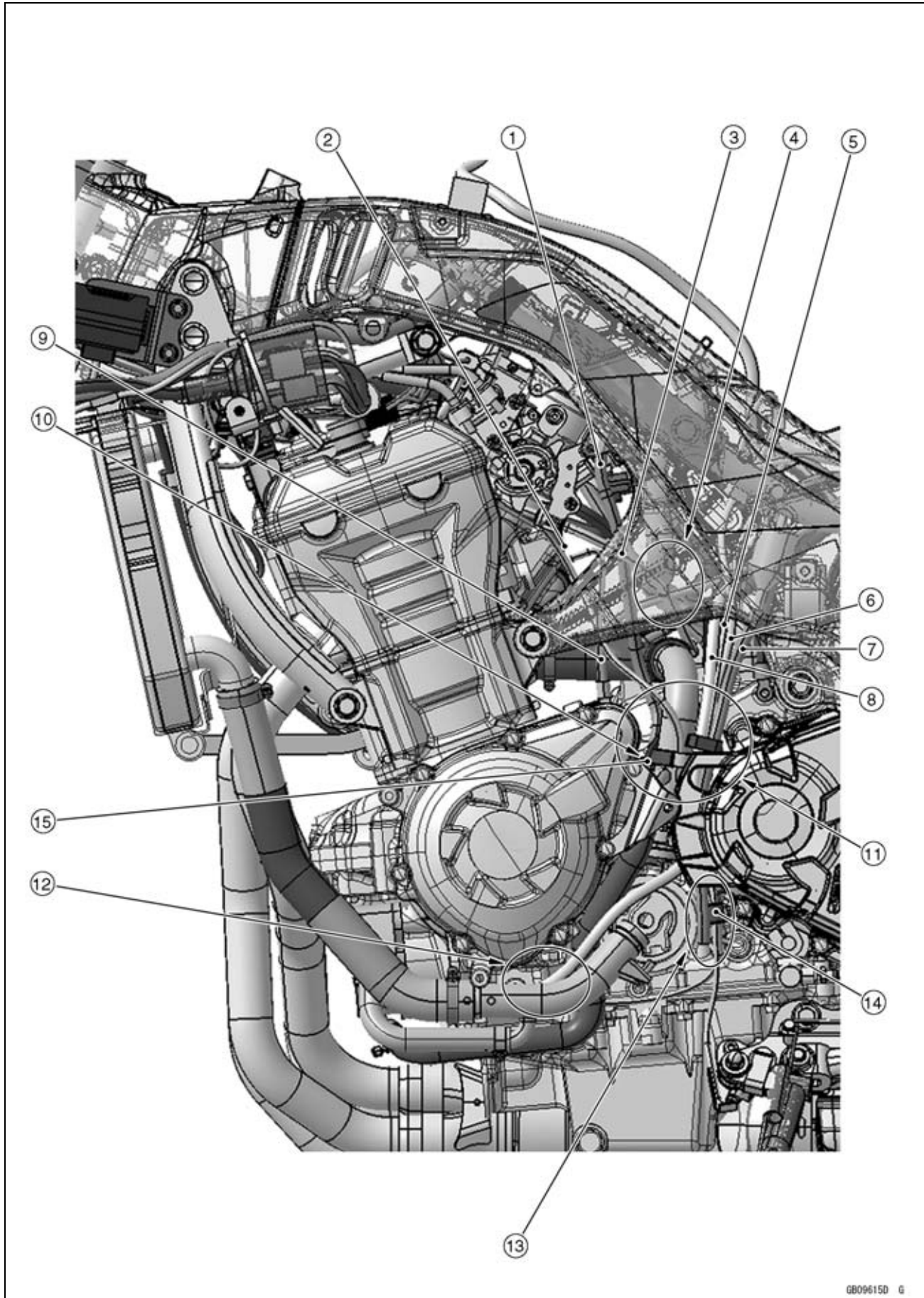

Cable, Wire, and Hose Routing

1. Air Cleaner Drain Hose
2. Neutral Switch/Oil Pressure Switch Lead
3. Idle Adjusting Screw
4. Run the starter motor cable to the upside of the idle adjusting screw.
5. Sidestand Switch Lead
6. Speed Sensor Lead
7. Fuel Tank Breather Hose (other than CAL and SEA-B1 models)
8. Fuel Tank Drain Hose
9. Starter Motor Cable
10. Run the alternator lead to the outside of air cleaner drain hose and inside of neutral switch/oil pressure switch lead.
11. Run the speed sensor lead and sidestand switch lead to the inside of the breather hose and fuel tank drain hose (other than CAL and SEA-B1 models).
12. Run the end of fuel tank drain hose is as shown.
13. Hold the sidestand switch lead with the clamp.
14. Clamp
15. Alternator Lead

17-24 APPENDIX

Cable, Wire, and Hose Routing

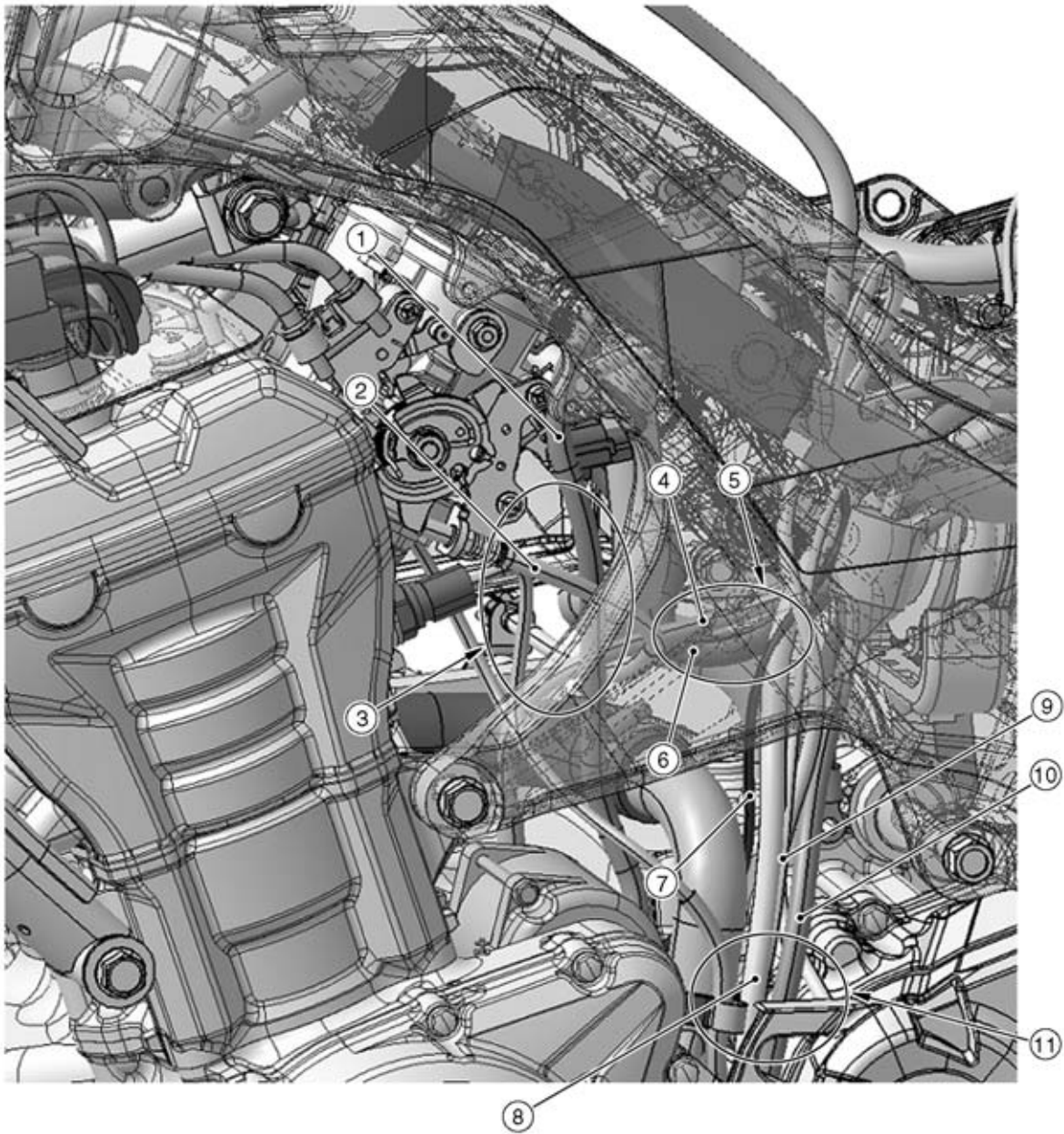

Cable, Wire, and Hose Routing

1. Air Cleaner Drain Hose
2. Idle Adjusting Screw
3. Run the idle adjusting screw to the under of the starter motor cable, outside of the air cleaner drain hose.
4. Starter Motor Cable
5. Run the fuel hose, starter motor cable, and alternator lead in order from the inside of the frame.
6. Fuel Hose
7. Alternator Lead
8. Fuel Tank Drain Hose
9. Sidestand Switch Lead
10. Fuel Tank Breather Hose (other than CAL and SEA-B1 Models)
11. Run the fuel tank breather hose (other than CAL and SEA-B1 models), sidestand switch lead and fuel tank drain hose to the inside of the chain cover.

17-26 APPENDIX

Cable, Wire, and Hose Routing

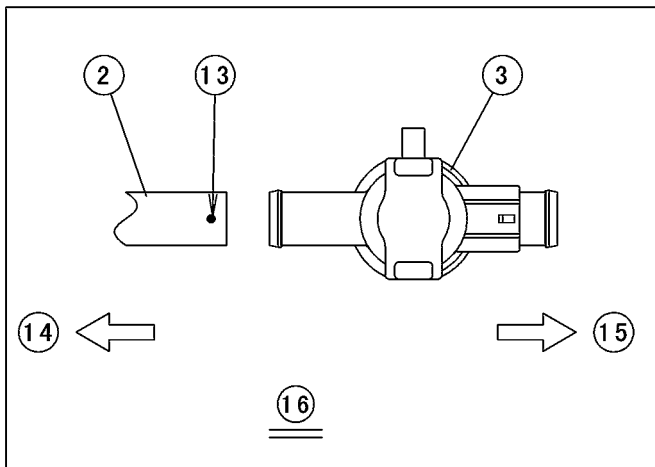
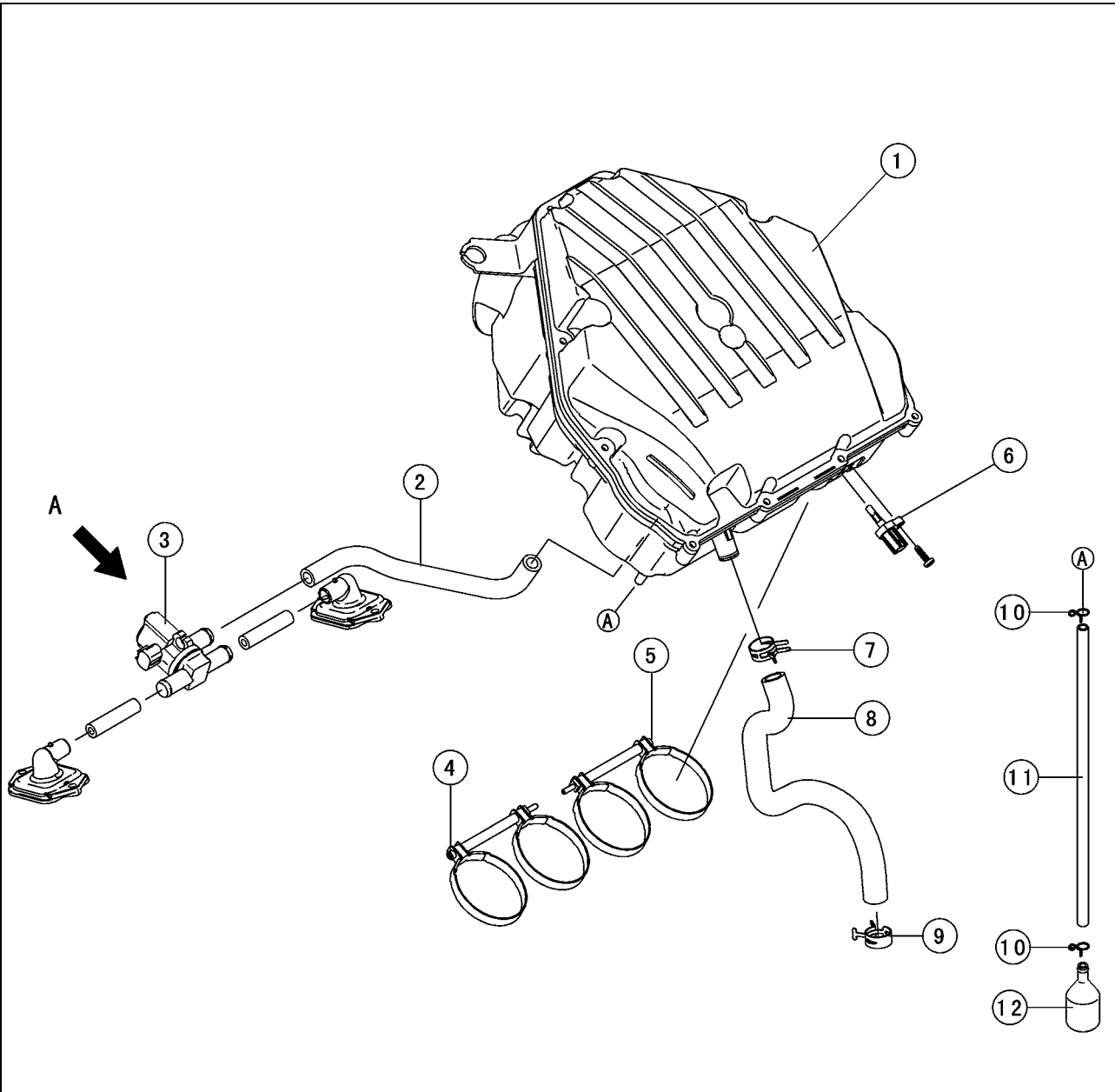

Cable, Wire, and Hose Routing

1. Air Cleaner Housing
2. Air Switching Valve Hose
3. Air Switching Valve
4. Tighten the clamp bolt from left side.
5. Tighten the clamp bolt from right side.
6. Intake Air Temperature Sensor
7. Install the clamp so that knob of the clamp faces rear side of the frame as shown.
8. Breather Hose
9. Clamp
10. Clamps
11. Air Cleaner Drain Hose
12. Catch Tank
13. White Paint Mark
14. Right
15. Left
16. Viewed from A

17-28 APPENDIX

Cable, Wire, and Hose Routing

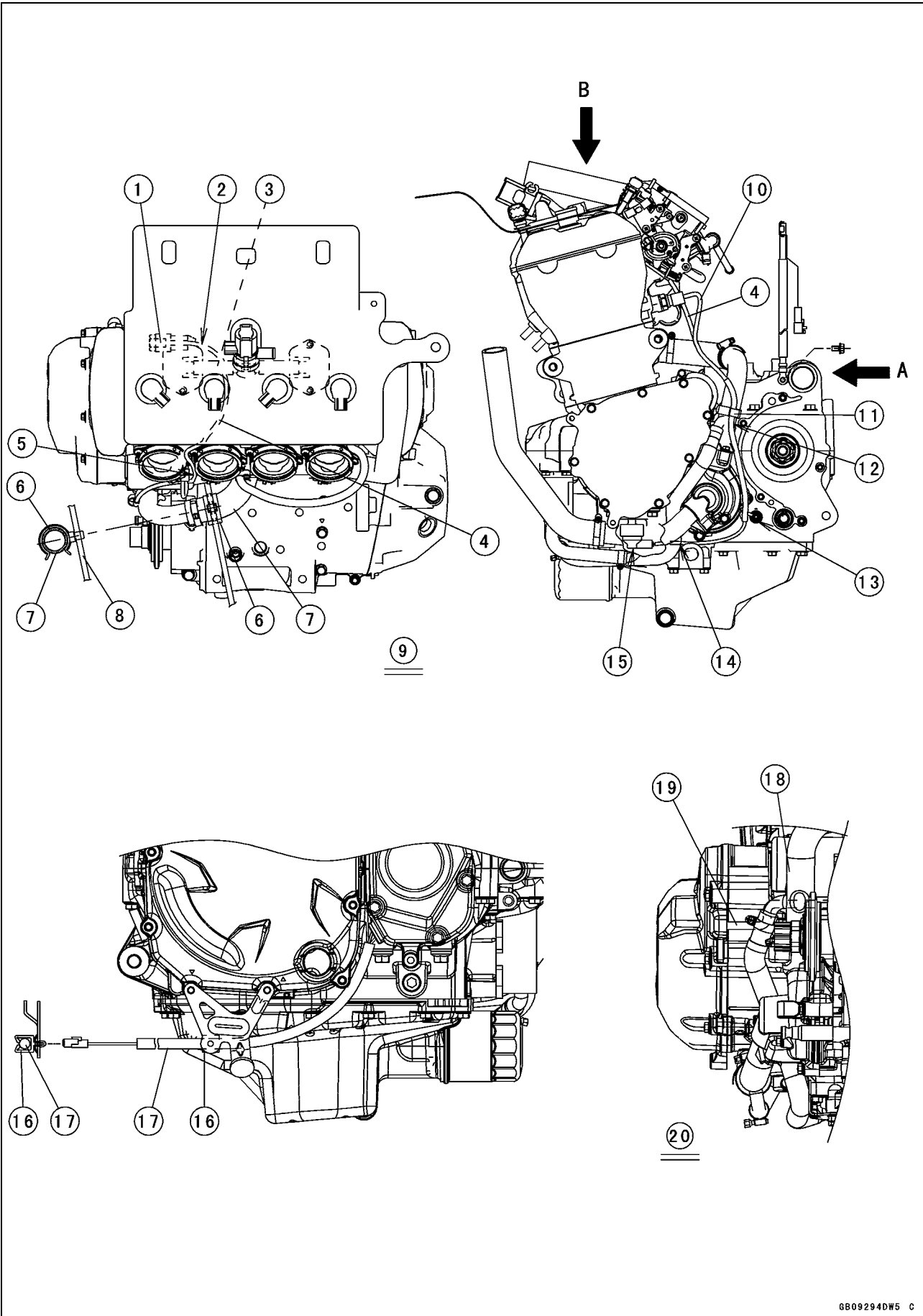

Cable, Wire, and Hose Routing

1. Insert the subharness connector to the clamp on the air suction valve cover.
2. Run the subharness under the hose.
3. Hose
4. Subharness
5. Run the subharness between the #1 and #2 throttle body holders so as not to pinch the lead with the throttle body assy.
6. Install the clamp as shown in the direction.
7. Water Hose
8. Starter Motor Cable
9. Viewed from B
10. Water Temperature Sensor Lead
11. Hold the neutral switch/oil pressure switch lead with the clamp at the upside of the separate pipe of the water pipe.
12. Run the neutral switch/oil pressure switch lead with the clamp at the rear side of the separate pipe of the water pipe.
13. Connect the neutral switch lead to the neutral switch. Do not stretch the lead after connected.
14. Run the oil pressure switch lead to the inside of the water pipe.
15. Cover the oil pressure switch with the switch cover.
16. Hold the crankshaft sensor lead with the clamp.
17. Crankshaft Sensor Lead
18. Water pipe
19. Run the alternator lead between the crankcase and water pipe.
20. Viewed from A

17-30 APPENDIX

Cable, Wire, and Hose Routing

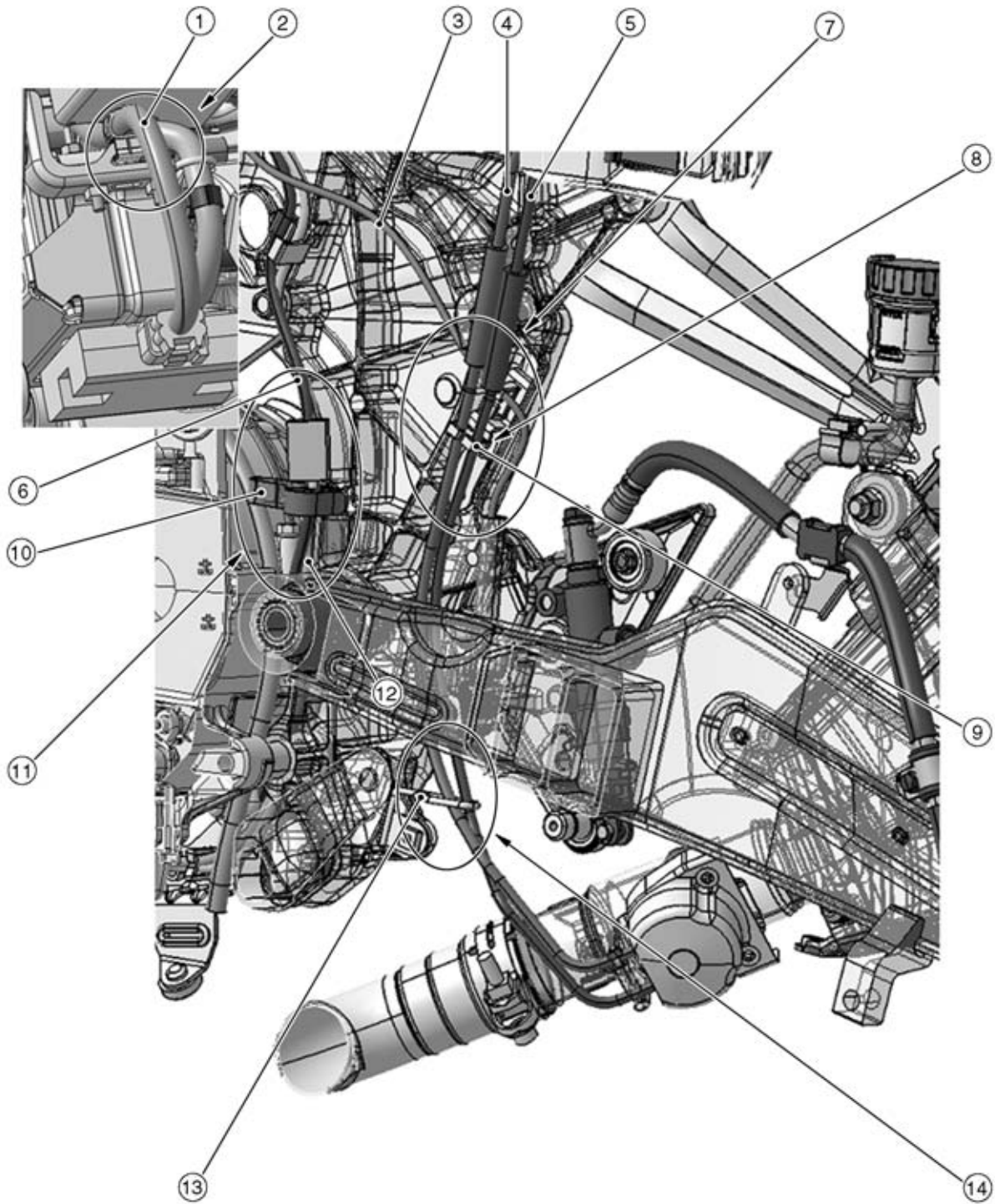

Cable, Wire, and Hose Routing

1. Regulator/Rectifier Harness
2. Hold the regulator/rectifier harness with clamp.
3. Rear Brake Light Switch Lead
4. Exhaust Butterfly Valve Open Cable
5. Exhaust Butterfly Valve Close Cable
6. Oxygen Sensor Lead (Equipped Models)
7. Run the rear brake light switch lead through the clamp to outside of exhaust butterfly valve cables.
8. Run the exhaust butterfly valve open cable and close cable through the clamp in order from the front.
9. Clamp (for Exhaust Butterfly Valve Cables)
10. Clamp (for Oxygen Sensor Lead and Crankshaft Sensor Lead)
11. Bend the clamp rearward to secure the oxygen sensor lead and crankshaft sensor lead.
12. Crankshaft Sensor Lead
13. Clamp (for Exhaust Butterfly Valve Cable)
14. Run the exhaust butterfly valve open cable and close cable through the clamp in order from the front.

17-32 APPENDIX

Cable, Wire, and Hose Routing

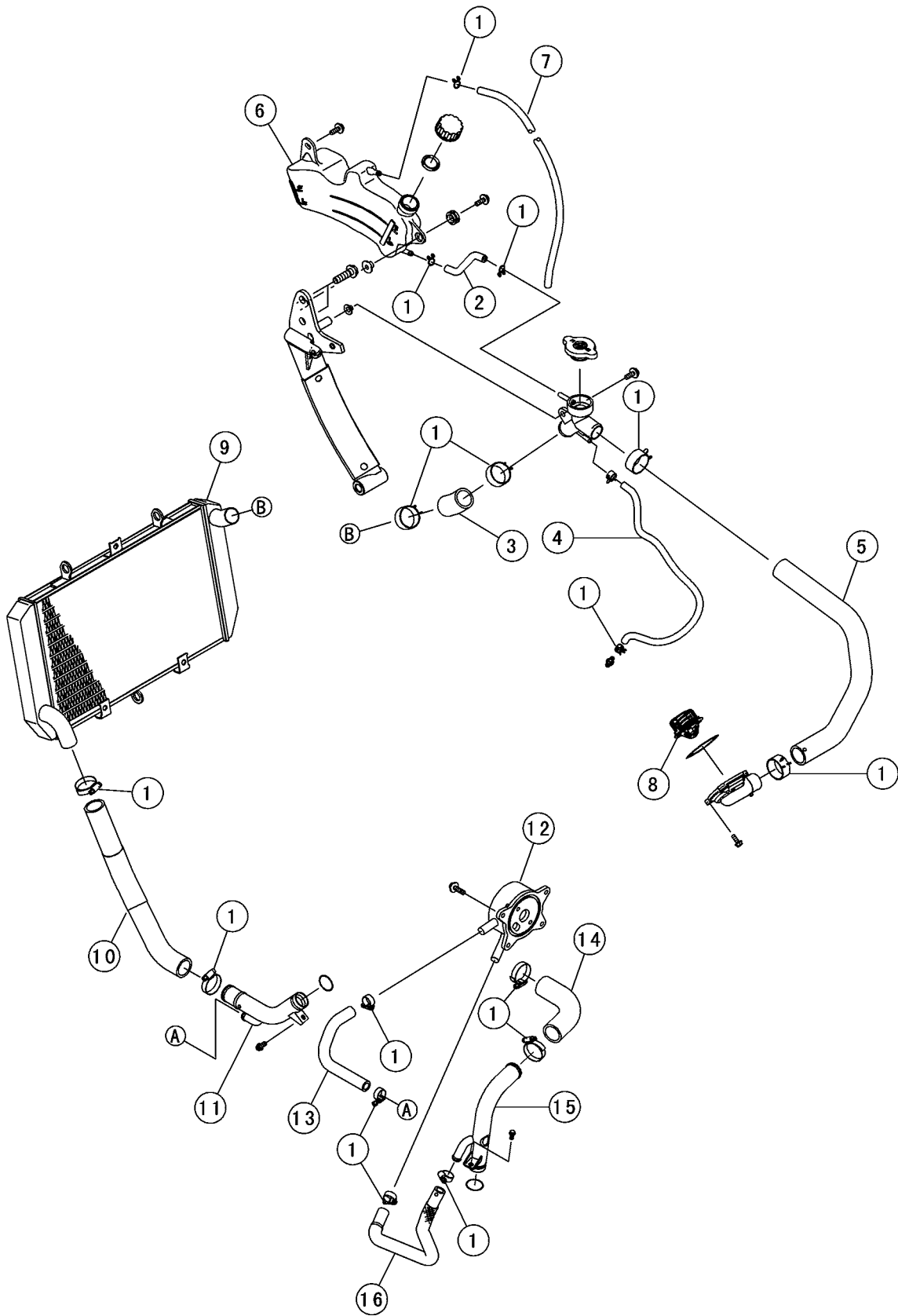

Cable, Wire, and Hose Routing

1. Install the clamps as shown in the direction.
2. Reserve Tank Hose
3. Radiator Hose
4. Water Hose
5. Water Hose
6. Reserve Tank
7. Reserve Tank Overflow Hose
8. Thermostat
9. Radiator
10. Radiator Hose
11. Water Pipe
12. Oil Cooler
13. Water Hose
14. Water Hose
15. Water Pipe
16. Water Hose

17-34 APPENDIX

Cable, Wire, and Hose Routing

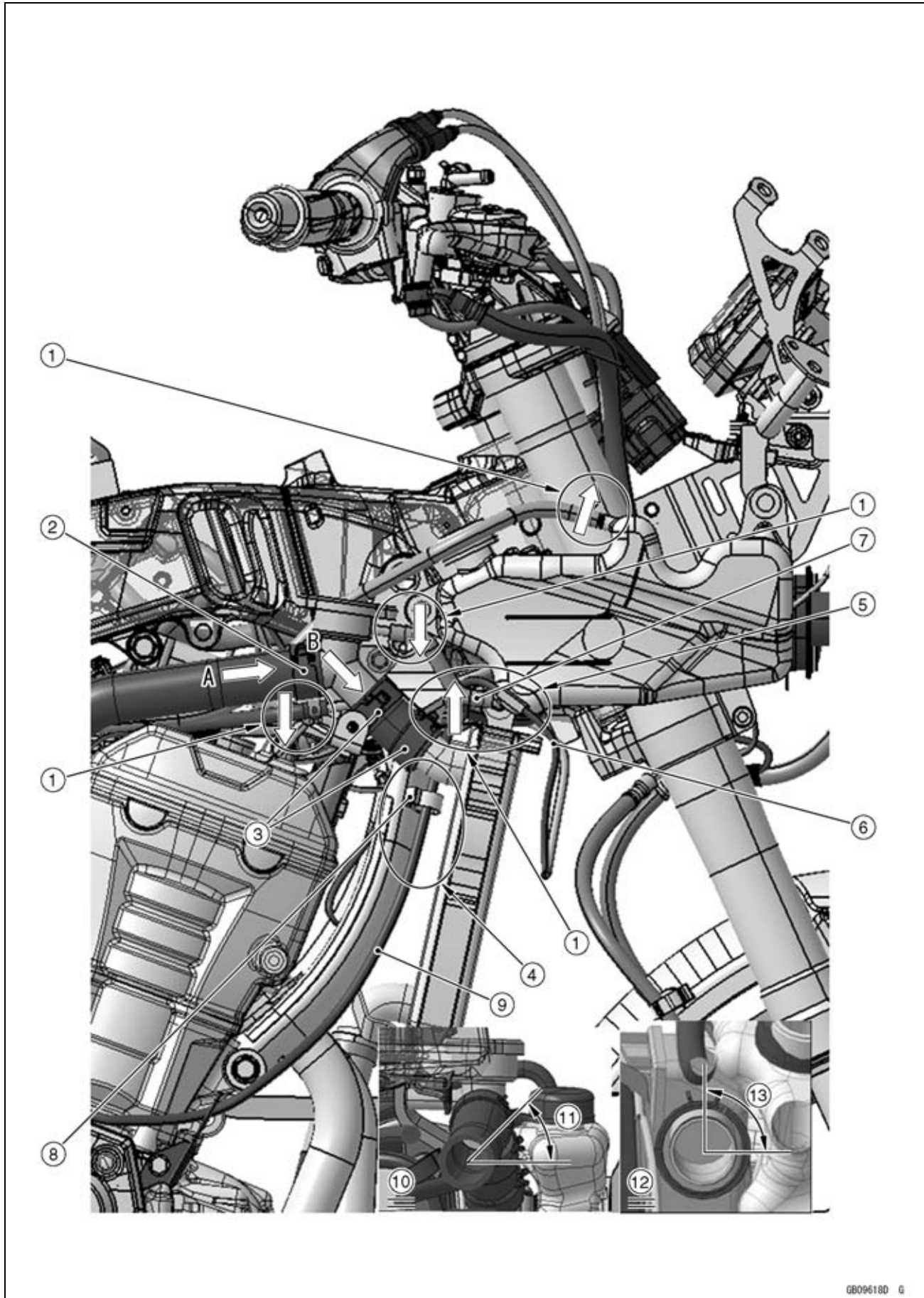

Cable, Wire, and Hose Routing

1. Install the clamps so that its opening facing the direction indicated with arrow.
2. Clamp (for Water Hose)
3. Clamp (for Radiator Hose)
4. Hold the clutch cable with clamp.
5. Run the front right turn signal light lead to the upside of the reserve tank overflow hose.
6. Front Turn Signal Light Lead
7. Reserve Tank Overflow Hose
8. Clamp (for Clutch Cable)
9. Clutch Cable
10. Viewed From A
11. About 45°
12. Viewed From B
13. About 90°

17-36 APPENDIX

Cable, Wire, and Hose Routing

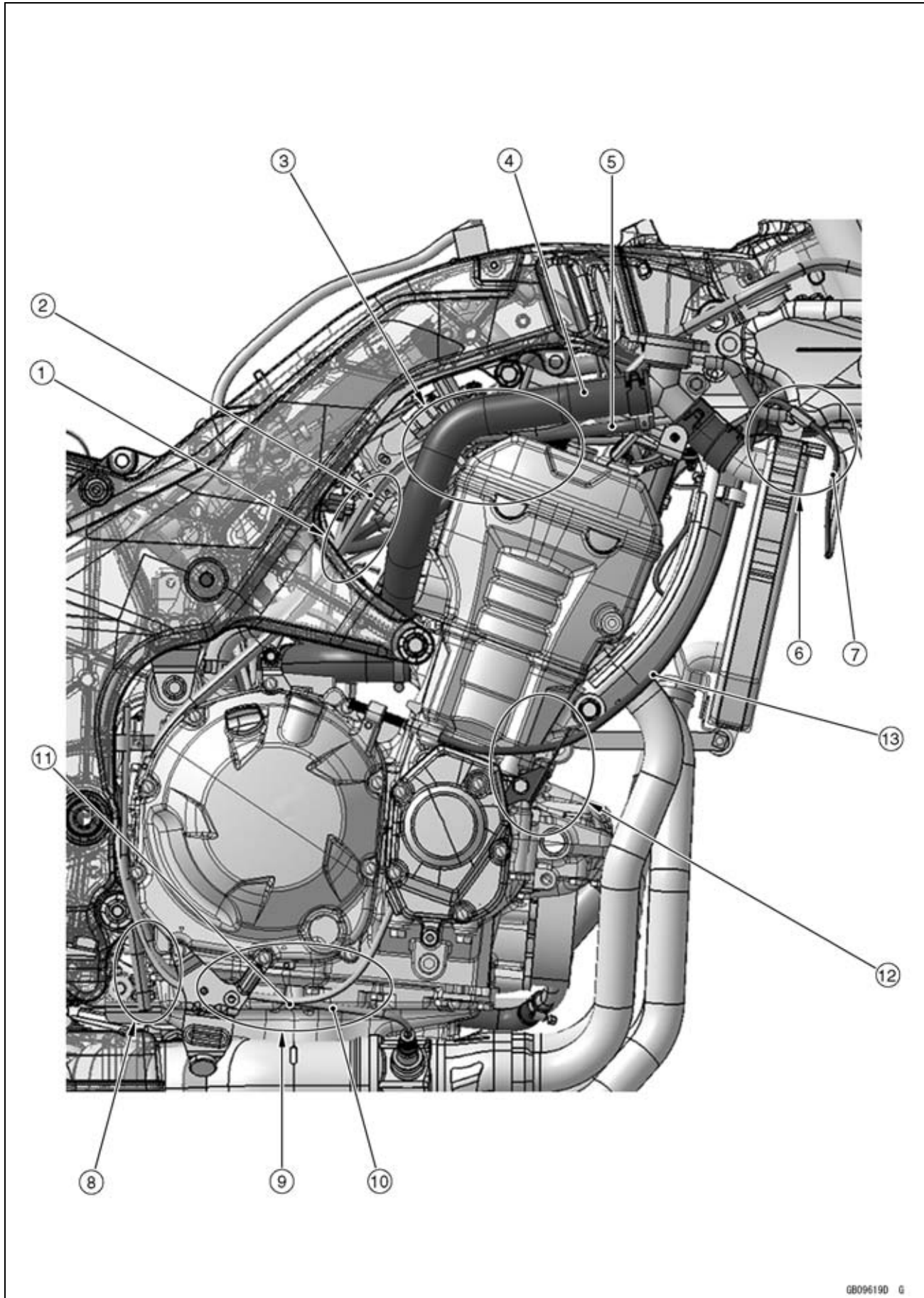

Cable, Wire, and Hose Routing

1. Run the reserve tank overflow hose to the inside of the frame.
2. Reserve Tank Overflow Hose
3. Run the water hose, reserve tank overflow hose, water hose in order the outside of frame.
4. Water Hose
5. Water Hose
6. Connect the right turn signal light lead at the rear of radiator side pad, and push its connector into the cutout on the pad.
7. Right Turn Signal Light Lead
8. Run the reserve tank overflow hose to behind of the adjusting bolt, and between the adjusting bolt and frame, and directs it to underside of the frame.
9. Hold the oxygen sensor lead (equipped models) and crankshaft sensor lead with clamp.
10. Oxygen Sensor Lead
11. Crankshaft Sensor Lead
12. Run the clutch cable to front of engine bracket through the clamp on the front of the crankshaft sensor cover and inside of upper radiator hose.
13. Clutch Cable

17-38 APPENDIX

Cable, Wire, and Hose Routing

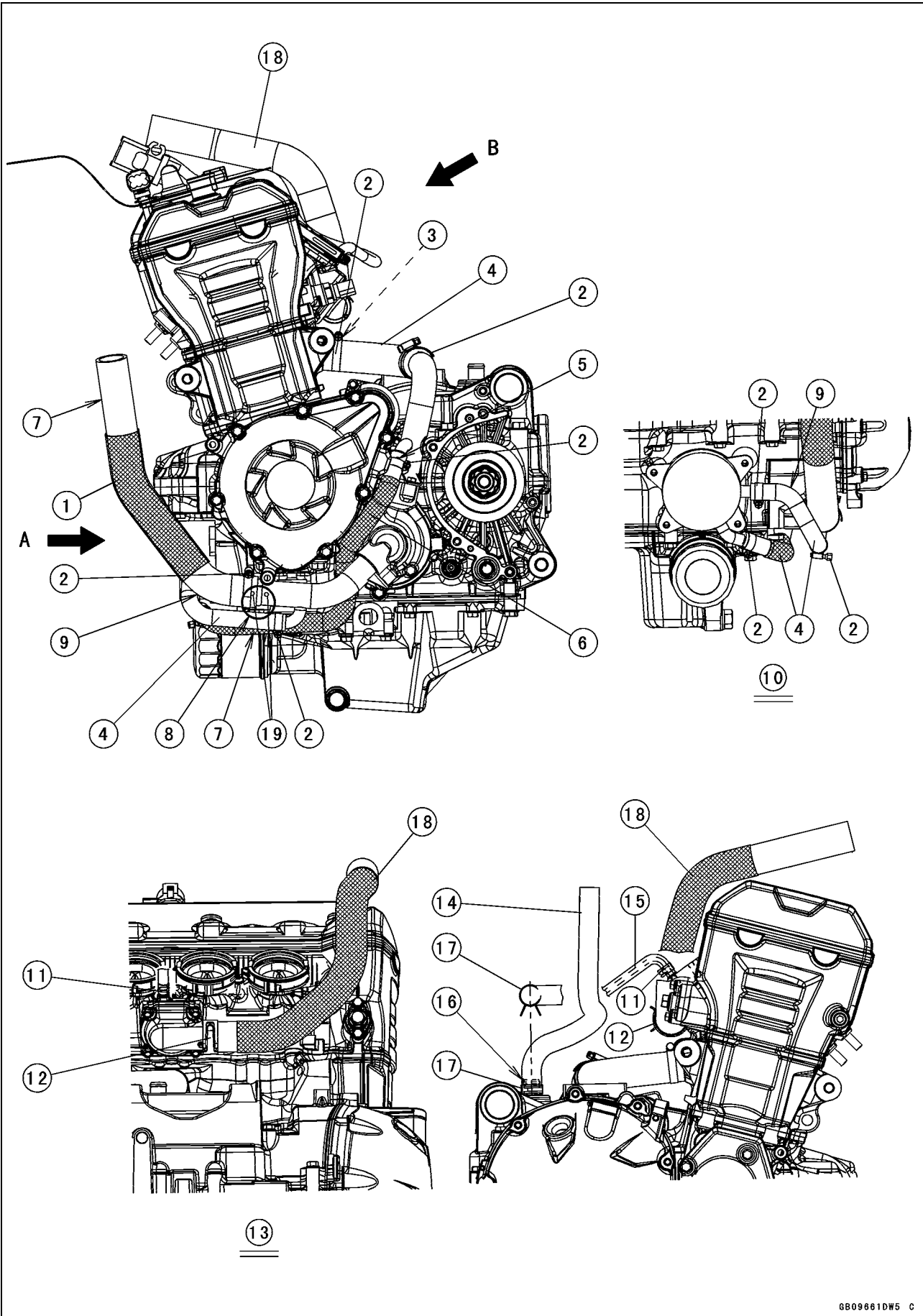

Cable, Wire, and Hose Routing

1. Radiator Hose
2. Install the clamps as shown, noting its screw head direction.
3. White Paint Mark (Install the water hose so that the white paint mark faces upside of the engine.)
4. Water Hose
5. White Paint Mark (Install the water hose so that the white paint mark faces outside of the engine.)
6. Water Hose
7. Straight Side
8. Install the radiator hose until the rised portion of the water pipe.
9. Curve Side
10. Viewed from A
11. Install the clamp so that the tab of the clamp faces rear side of the engine.
12. Install the clamp at the thermostat housing so that the tab of the clamp faces rear side of the engine.
13. Viewed from B
14. Breather Hose
15. Water Hose
16. White Paint Mark
17. Install the clamp so that the tab of the clamp faces right side of the engine.
18. Water Hose
19. White Paint Mark (Install the water hose and water pipe so that the white paint mark faces outside of the engine.)

17-40 APPENDIX

Cable, Wire, and Hose Routing

ABS Equipped Models

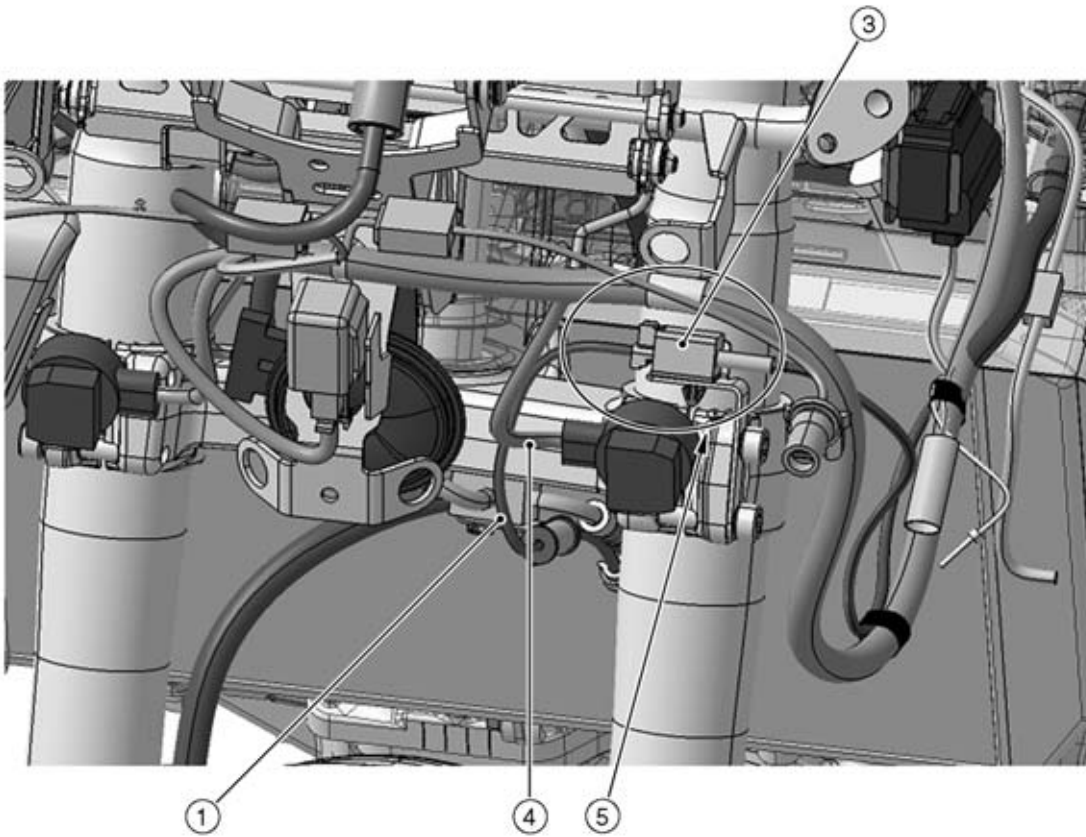
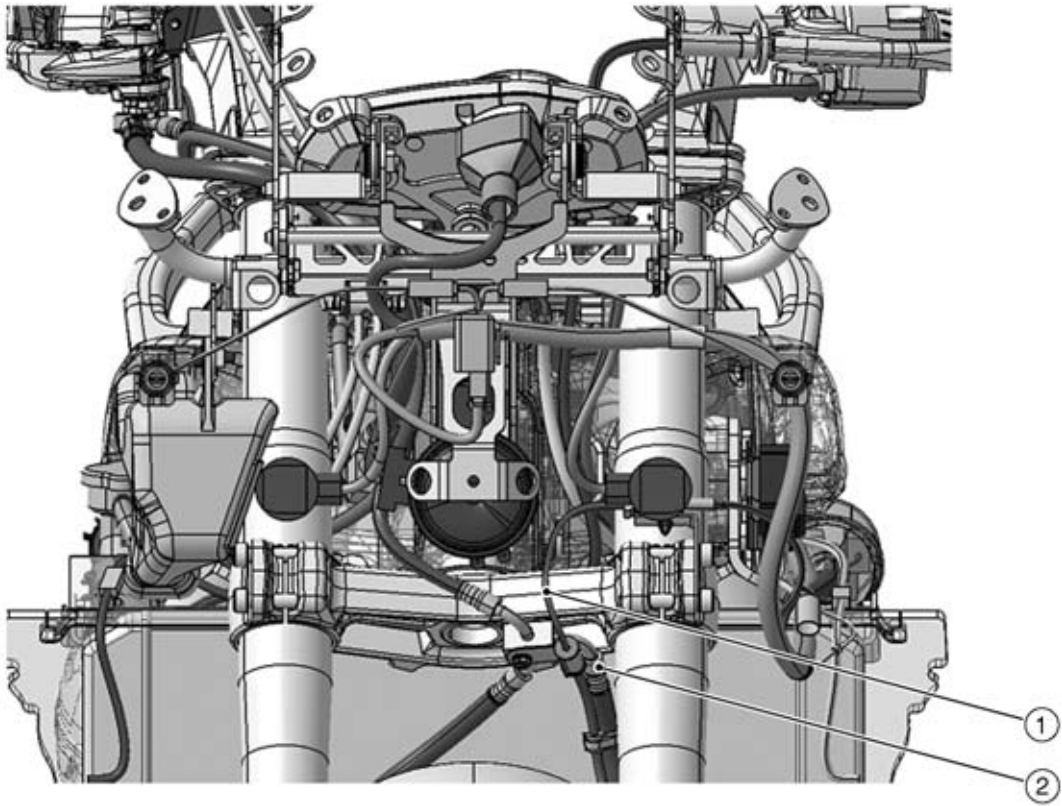

Cable, Wire, and Hose Routing

1. Front Wheel Rotation Sensor Lead
2. Clamps (for Brake Hose and Front Wheel Rotation Sensor Lead)
3. Front Wheel Rotation Sensor Connector
4. Headlight Lead
5. Run the front wheel rotation sensor lead to the outside of the headlight lead, and connect the front wheel rotation sensor connector at the front fork bracket.

17-42 APPENDIX

Cable, Wire, and Hose Routing

ABS Equipped Models

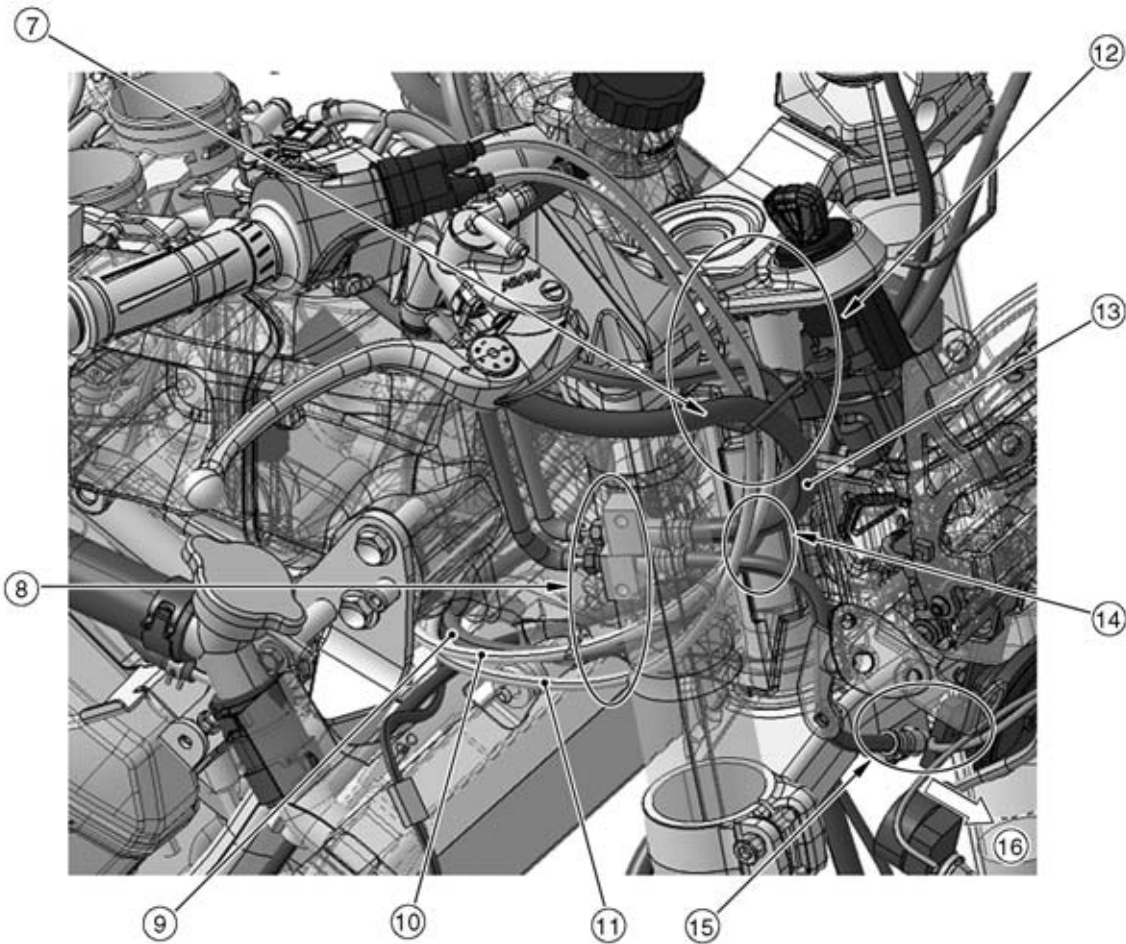
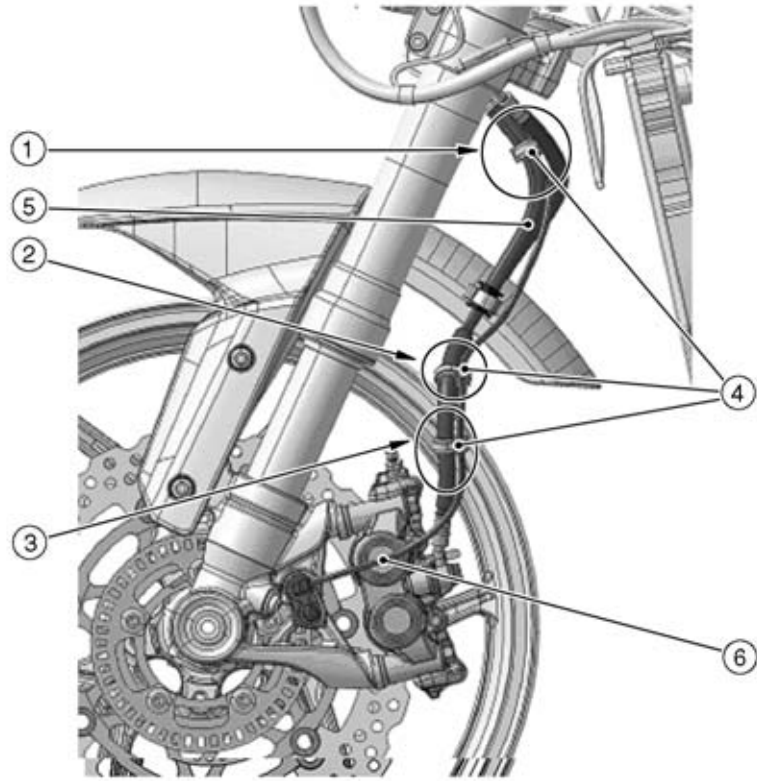

Cable, Wire, and Hose Routing

1. Hold the brake hose inside the front wheel rotation sensor lead with clamp. Install the clamp with its closed side facing forward.
2. Hold the brake hose at the rubber portions with the clamp.
3. Run the front wheel rotation sensor lead to the rear side of the brake hose. Install the clamp with its closed side facing outside.
4. Clamp (for Front Wheel Rotation Sensor Lead and Brake Hose)
5. Brake Hose
6. Front Wheel Rotation Sensor Lead
7. Run the brake hose to the most forward side, and the right switch housing lead to the most behind of the other leads and run them into the clamp.
8. Run the brake hose, right switch housing lead, throttle cable (accelerator) and throttle cable (decelerator) in order from the outside of frame.
9. Right Switch Housing Lead
10. Throttle Cable (Accelerator)
11. Throttle Cable (Decelerator)
12. Run the brake hose, throttle cable (decelerator), throttle cable (accelerator) and right switch housing lead in order from the outside of frame.
13. Brake Hose
14. Run the right switch housing lead to the inside of brake hose.
15. Run the brake hose to the most outside of the other lead.
16. Front

17-44 APPENDIX

Cable, Wire, and Hose Routing

ABS Equipped Models

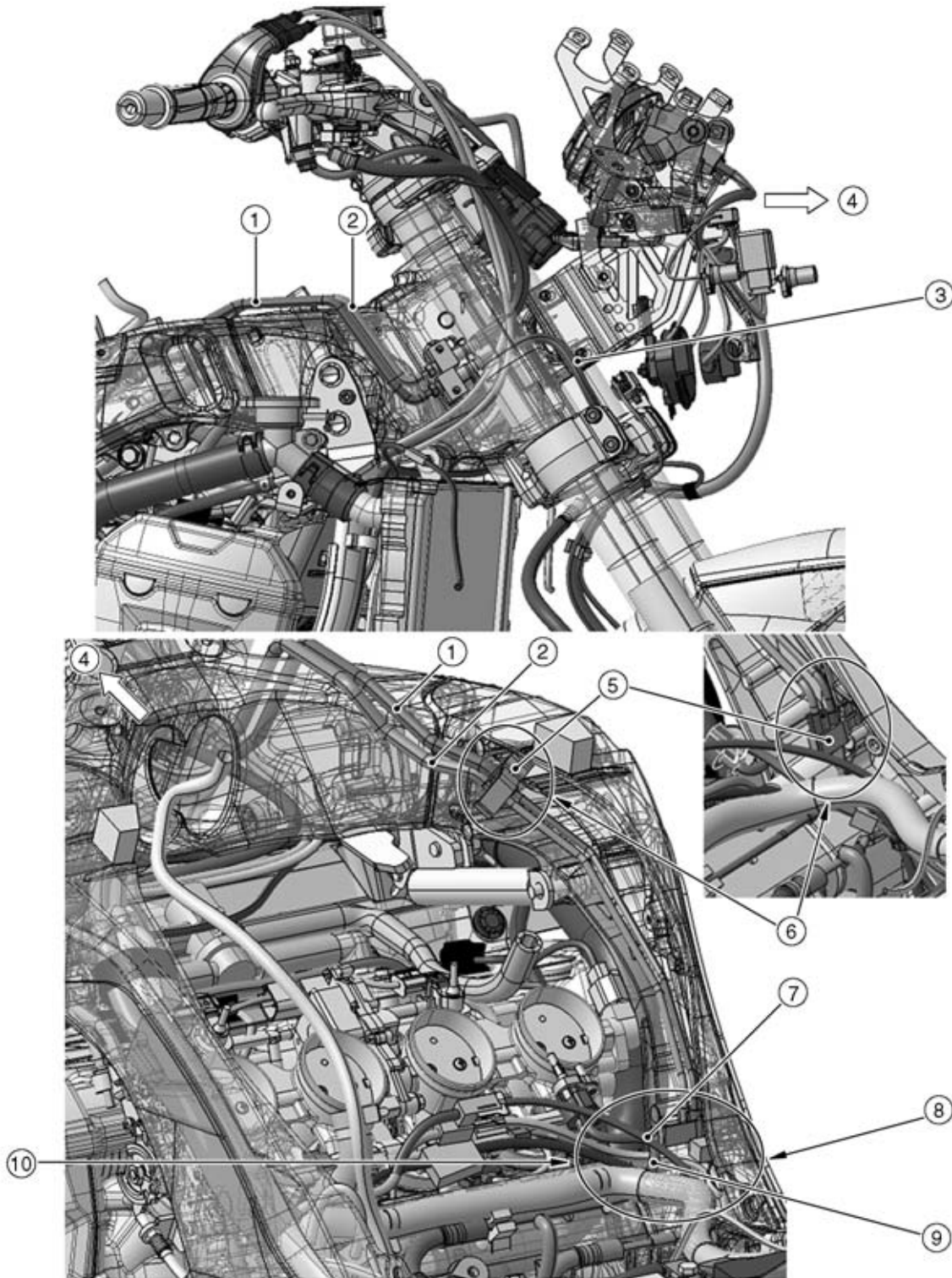

Cable, Wire, and Hose Routing

1. Brake Pipe
2. Brake Pipe
3. Brake Hose
4. Front
5. Clamp (Hold the brake pipes)
6. Hold the brake pipes at the rubber portions with the clamps.
7. Rear Wheel Rotation Sensor Lead
8. Run the rear wheel rotation sensor lead to the outside of the main harness and upper the intake air temperature sensor lead.
9. Intake Air Temperature Sensor Lead
10. Run the brake pipes under the harnesses.

17-46 APPENDIX

Cable, Wire, and Hose Routing

ABS Equipped Models

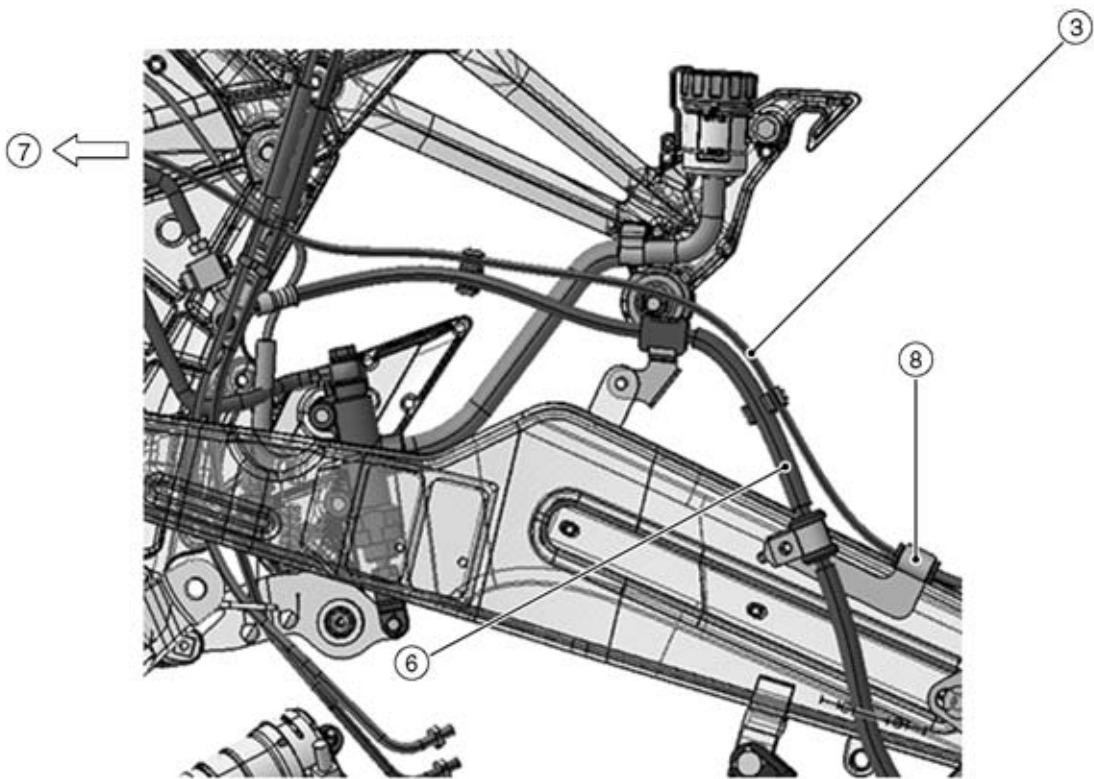
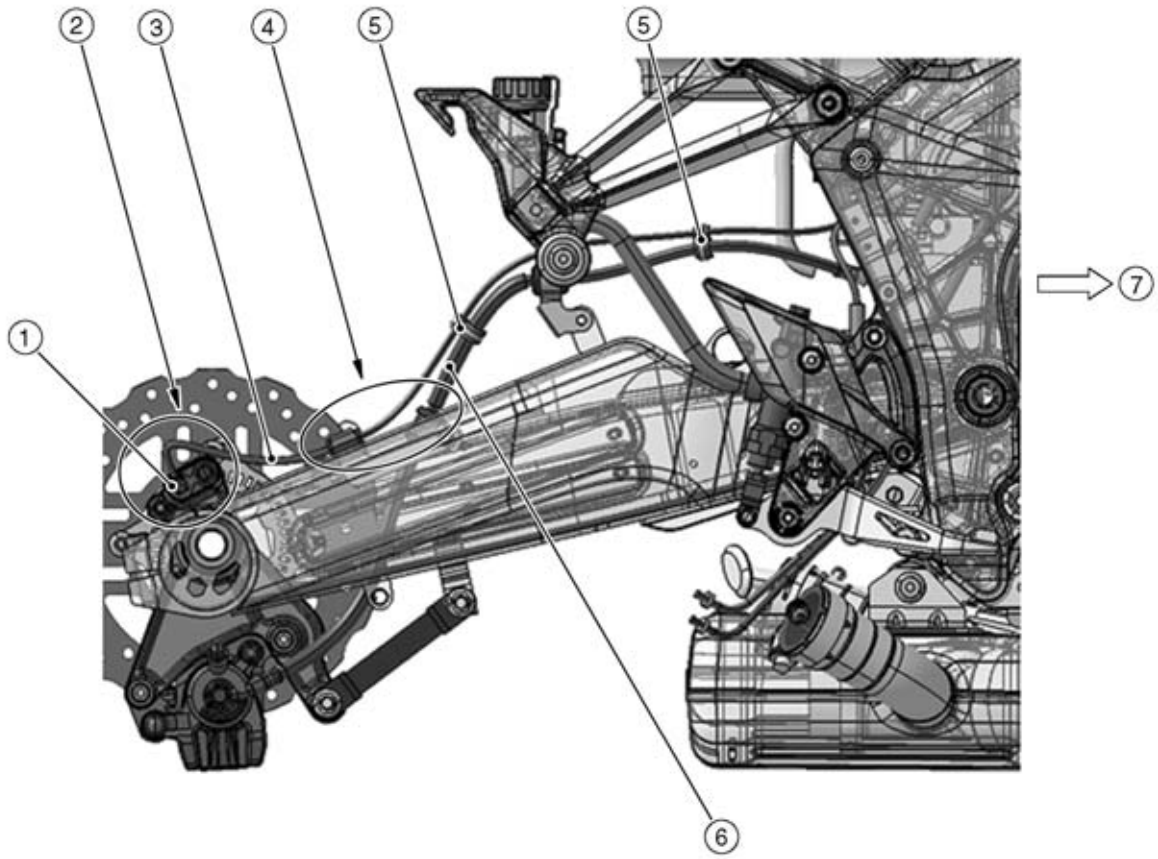

Cable, Wire, and Hose Routing

1. Rear Wheel Rotation Sensor
2. Run the rear wheel rotation sensor lead into the clamp.
3. Rear Wheel Rotation Sensor Lead
4. Run the rear wheel rotation sensor lead upper the brake hose, and hold the brake hose at the attaching mark with the clamp.
5. Clamp (for Brake Hose and Rear Wheel Rotation Sensor Lead)
6. Brake Hose
7. Front
8. Clamp (for Rear Wheel Rotation Sensor Lead)

17-48 APPENDIX

Cable, Wire, and Hose Routing

ABS Equipped Models

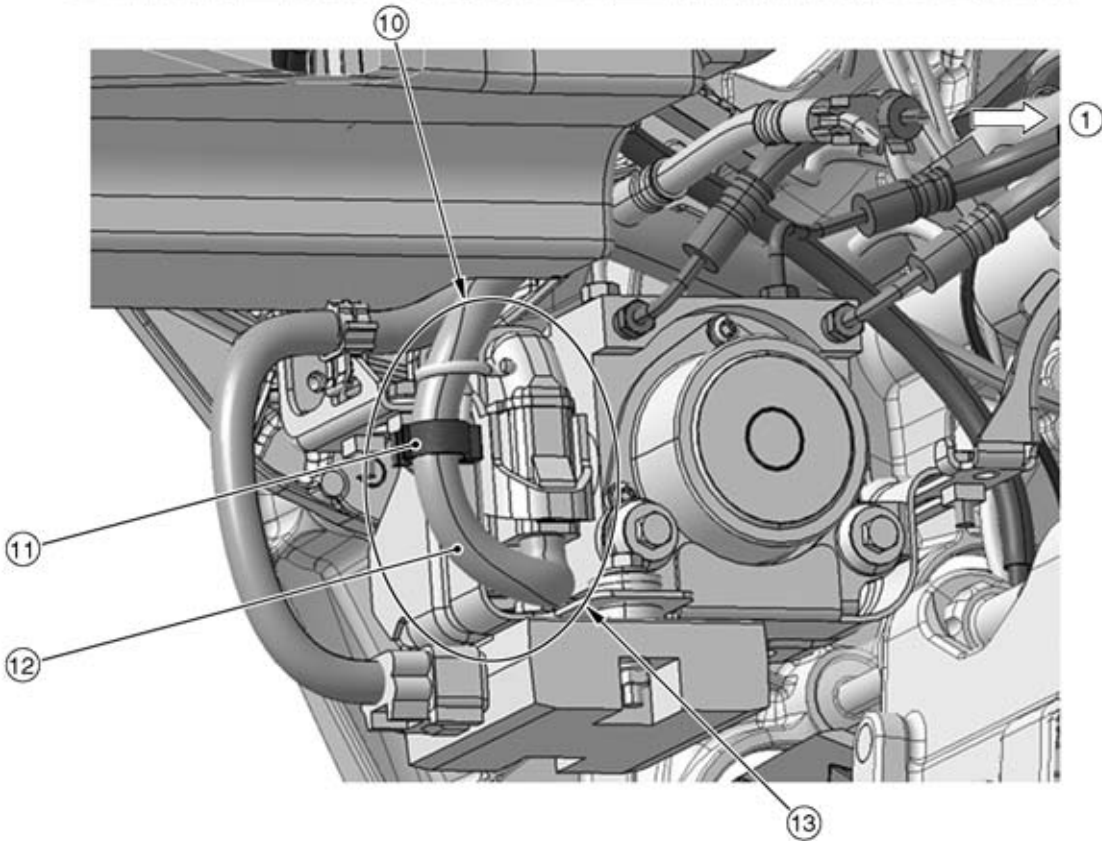
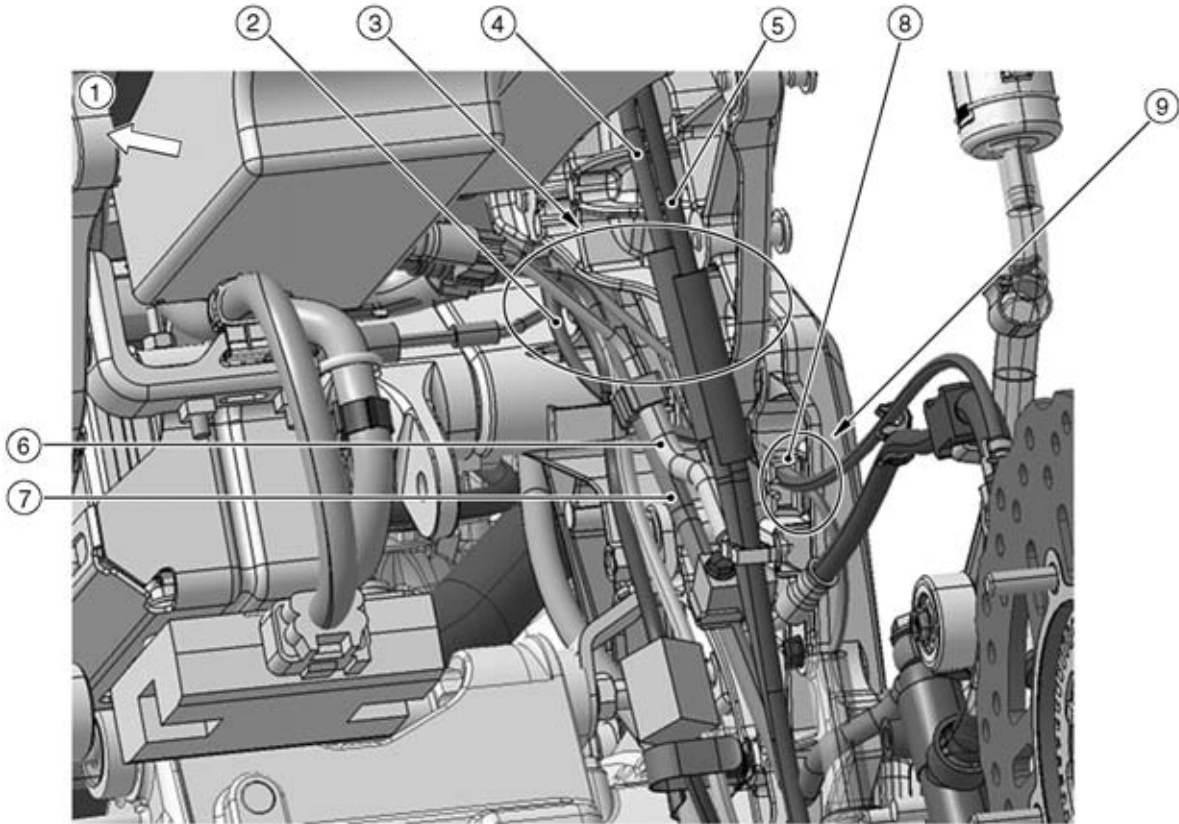

Cable, Wire, and Hose Routing

1. Front
2. Rear Wheel Rotation Sensor Lead
3. Run the exhaust butterfly valve close cable, exhaust butterfly valve open cable, brake hose, brake light switch lead, rear wheel rotation sensor lead in order from the inside of frame.
4. Exhaust Butterfly Valve Open Cable
5. Exhaust Butterfly Valve Close Cable
6. Brake Hose
7. Brake Hose
8. Clamp
9. Hold the brake light switch lead and rear wheel rotation sensor lead with clamp.
10. Run the ABS hydraulic unit harness under the battery case so that the harness has no play in this position (Run the under the battery case).
11. Clamp (for ABS Hydraulic Unit Harness)
12. ABS Hydraulic Unit Harness
13. Run the ABS hydraulic unit harness as shown.

17-50 APPENDIX

Cable, Wire, and Hose Routing

ABS Equipped Models

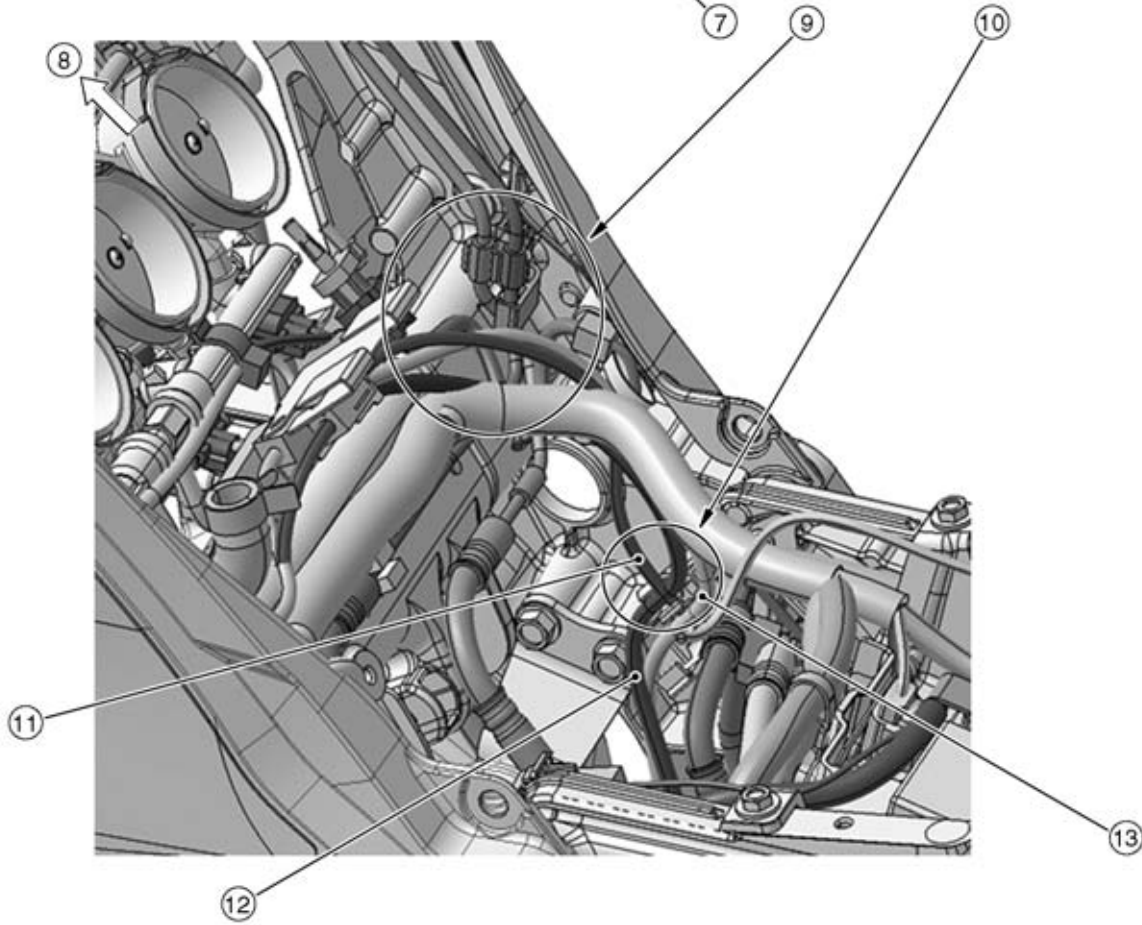
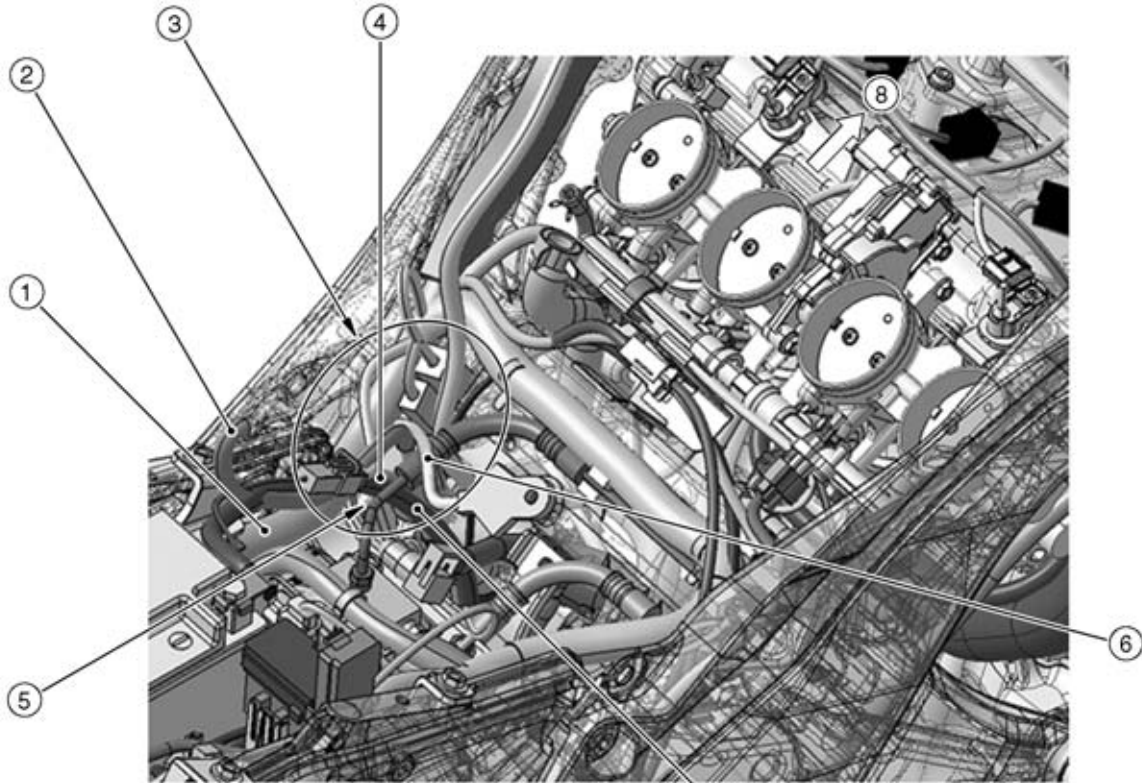

Cable, Wire, and Hose Routing

1. Air Cleaner Drain Hose
2. Breather Hose
3. Run the breather hose and air cleaner drain hose through the front side of frame ground lead and outside of the starter motor cable.
4. Starter motor (+) Cable
5. Run the brake pipe through the inside of the starter motor (+) cable and battery negative (-) cable and under the frame ground lead.
6. Frame Ground Lead
7. Battery Negative (-) Cable
8. Front
9. Run the brake hoses under the other harnesses.
10. Run the wheel rotation sensor lead and rear brake light switch lead to the outside of the oxygen sensor lead and crankshaft sensor lead.
11. Wheel Rotation Sensor Lead
12. Oxygen Sensor Lead
13. Crankshaft Sensor Lead

17-52 APPENDIX

Cable, Wire, and Hose Routing

ABS Equipped Models

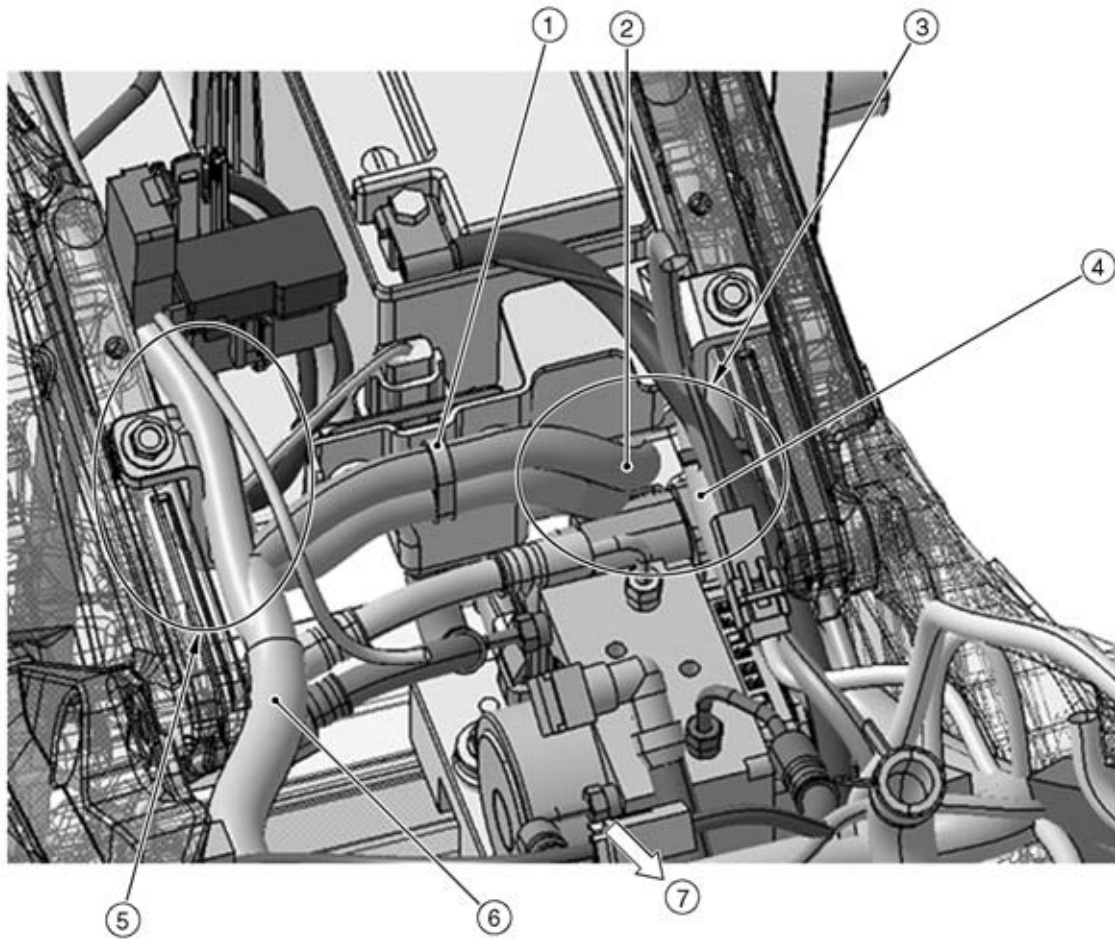

Cable, Wire, and Hose Routing

1. Clamp (Hold the each harness.)
2. Regulator/Rectifier Harness
3. Run the regulator/rectifier harness from the cutout on the battery case to underside of the battery case.
4. ABS Hydraulic Unit Harness
5. Run the rear of main harness to upside of the battery case, to rear of the battery case mount portion, and to outside of the battery case.
6. Main Harness
7. Front

17-54 APPENDIX

Cable, Wire, and Hose Routing

ABS Equipped Models

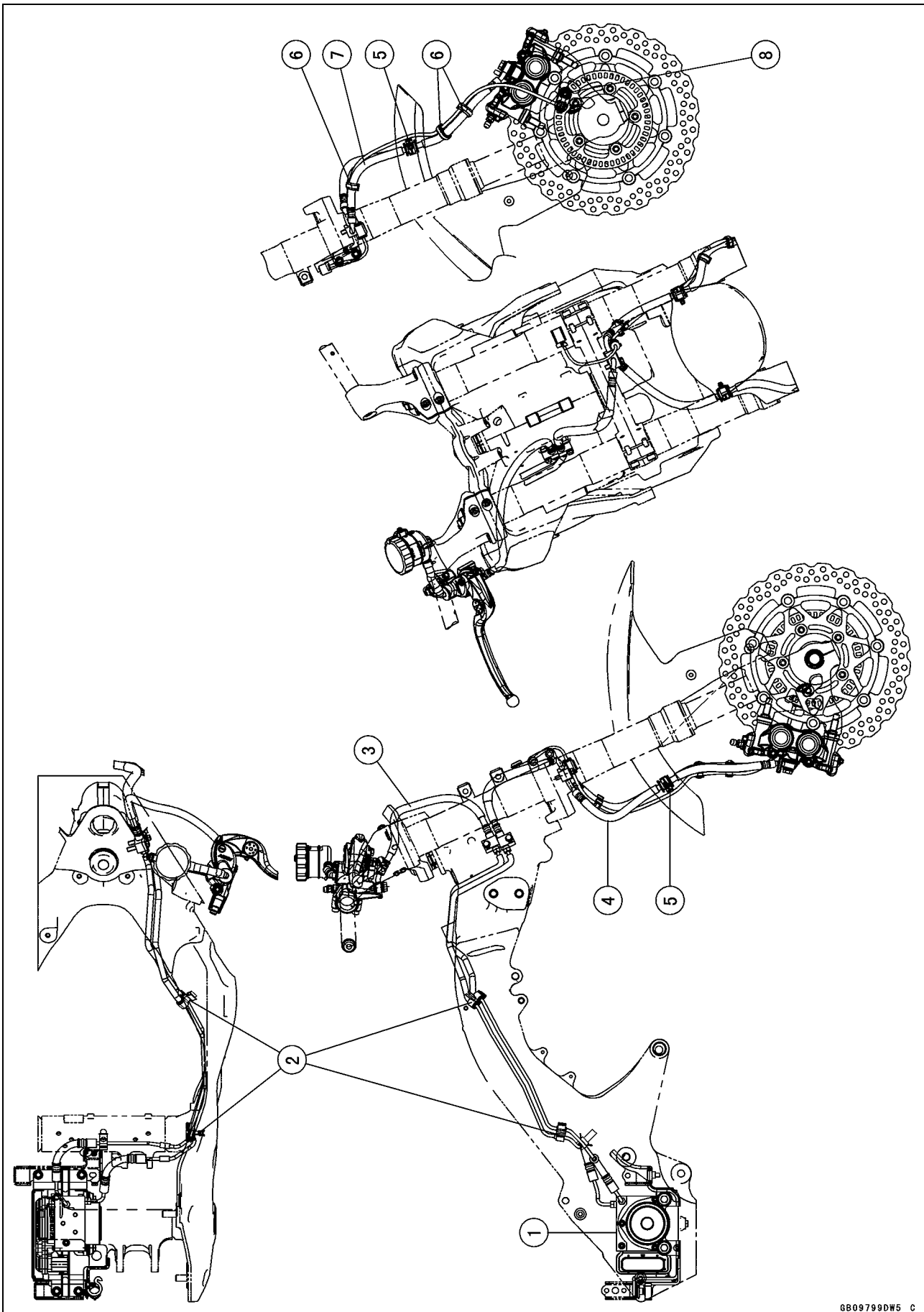

Cable, Wire, and Hose Routing

1. ABS Hydraulic Unit
2. Clamps
3. Brake Hose (between Front Master Cylinder and ABS Hydraulic Unit)
4. Brake Hose (between ABS Hydraulic Unit and Right Front Caliper)
5. Clamp (Hold the grommet of the brake hose only. For ZX1000HB late model ~, face the lock portion of the clamp backward.)
6. Hold the front brake hose and the front wheel rotation sensor lead with the clamp at the white painted portion of the sensor lead.
7. Brake Hose (between ABS Hydraulic Unit and Left Front Caliper)
8. Front Wheel Rotation Sensor

17-56 APPENDIX

Cable, Wire, and Hose Routing

ABS Equipped Models

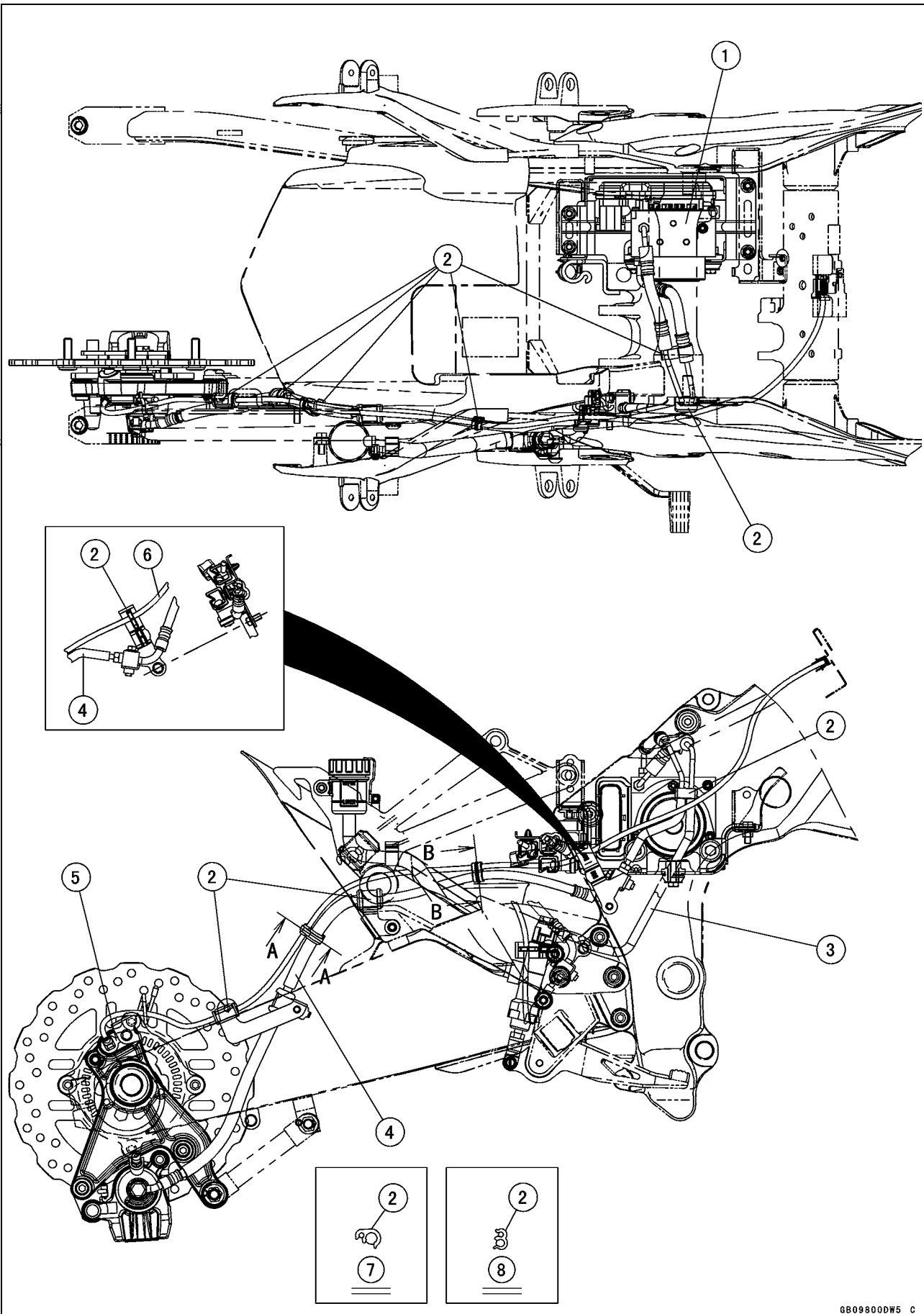

Cable, Wire, and Hose Routing

1. ABS Hydraulic Unit
2. Clamps
3. Brake Hose (between Rear Master Cylinder and ABS Hydraulic Unit)
4. Brake Hose (between ABS Hydraulic Unit and Rear Caliper)
5. Rear Wheel Rotation Sensor
6. Rear Wheel Rotation Sensor Lead
7. Section A-A
8. Section B-B

17-58 APPENDIX

Cable, Wire, and Hose Routing

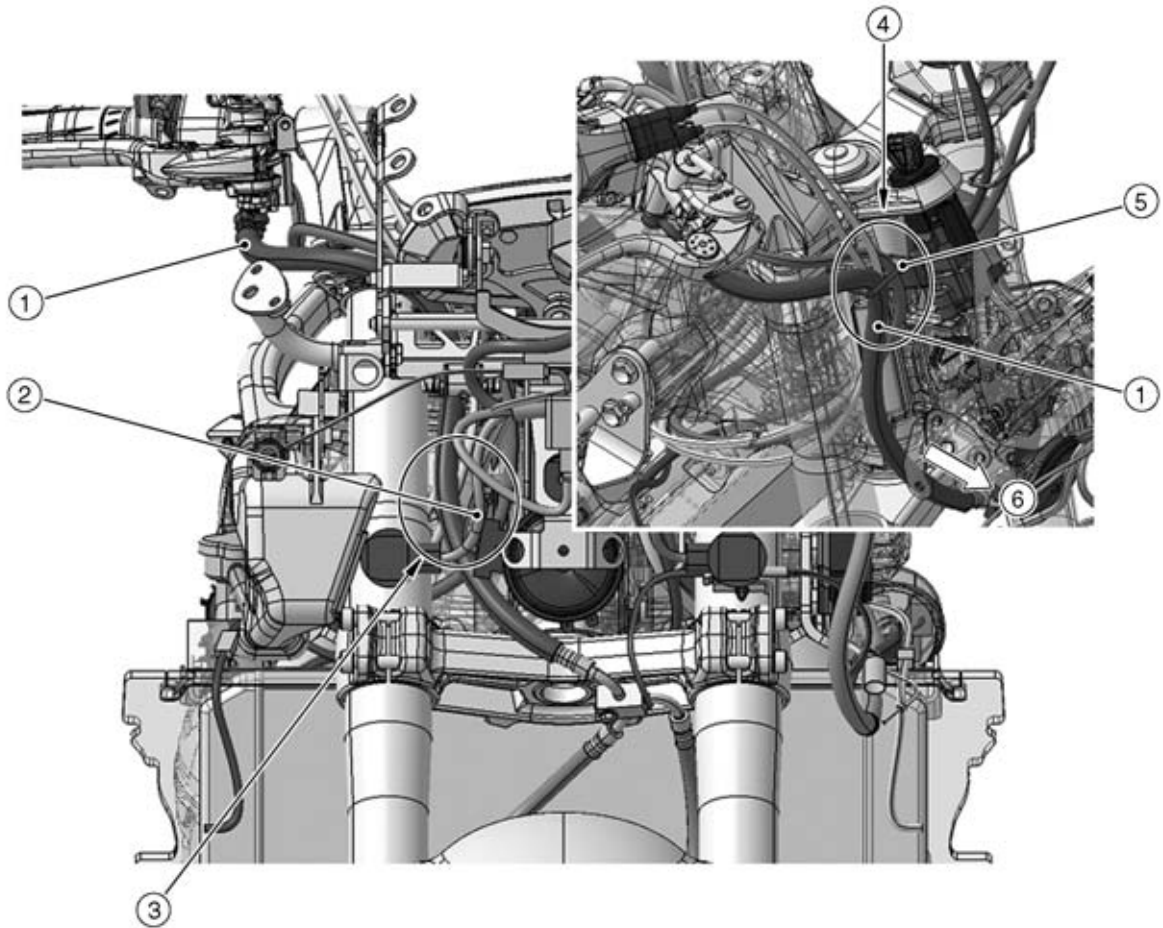

Cable, Wire, and Hose Routing

1. Brake Hose
2. Headlight Lead
3. Run the brake hose to the rear side of the headlight lead.
4. Run the brake hose to the most front side of the other leads and cables, and through it to the clamp.
5. Clamp
6. Front

17-60 APPENDIX

Cable, Wire, and Hose Routing

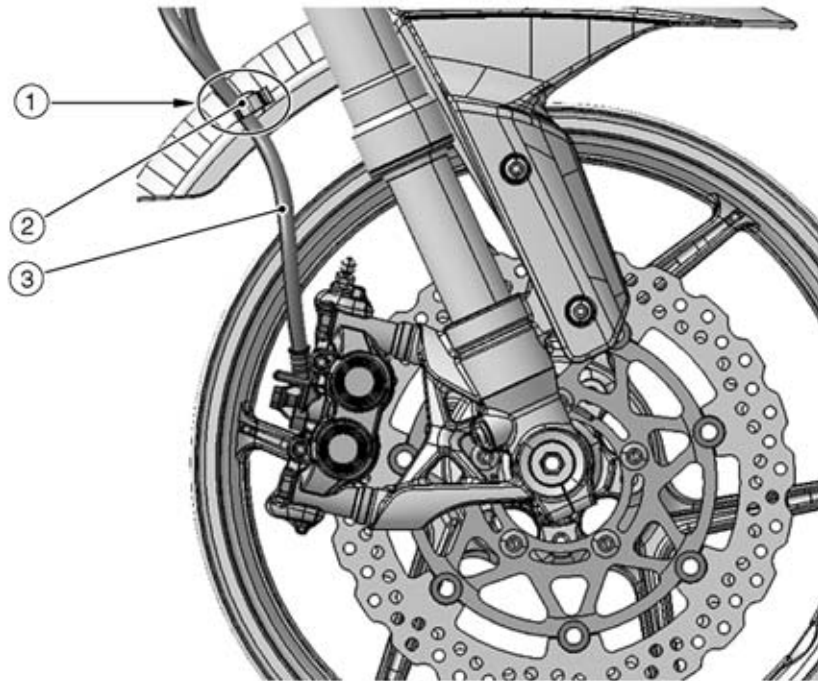
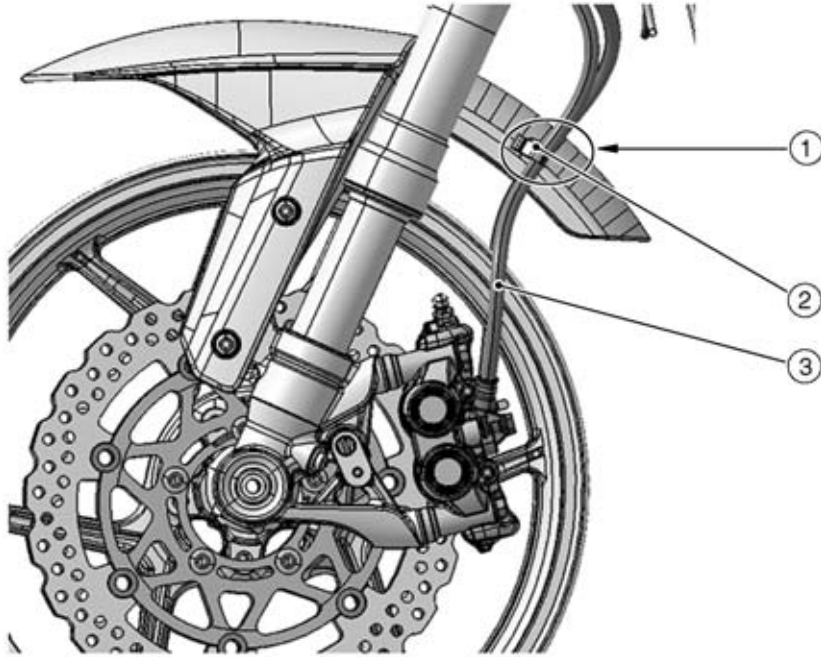

Cable, Wire, and Hose Routing

1. (ZX1000GB Early Model) Hold the brake hose with the clamp at the grommet of the brake hose, and insert it to the front fender.
(ZX1000GB Late Model ~) Hold the brake hose with the clamp at the grommet of the brake hose. Face the lock portion of the clamp backward.
2. Clamp (for Brake Hose)
3. Brake Hose

17-62 APPENDIX

Cable, Wire, and Hose Routing

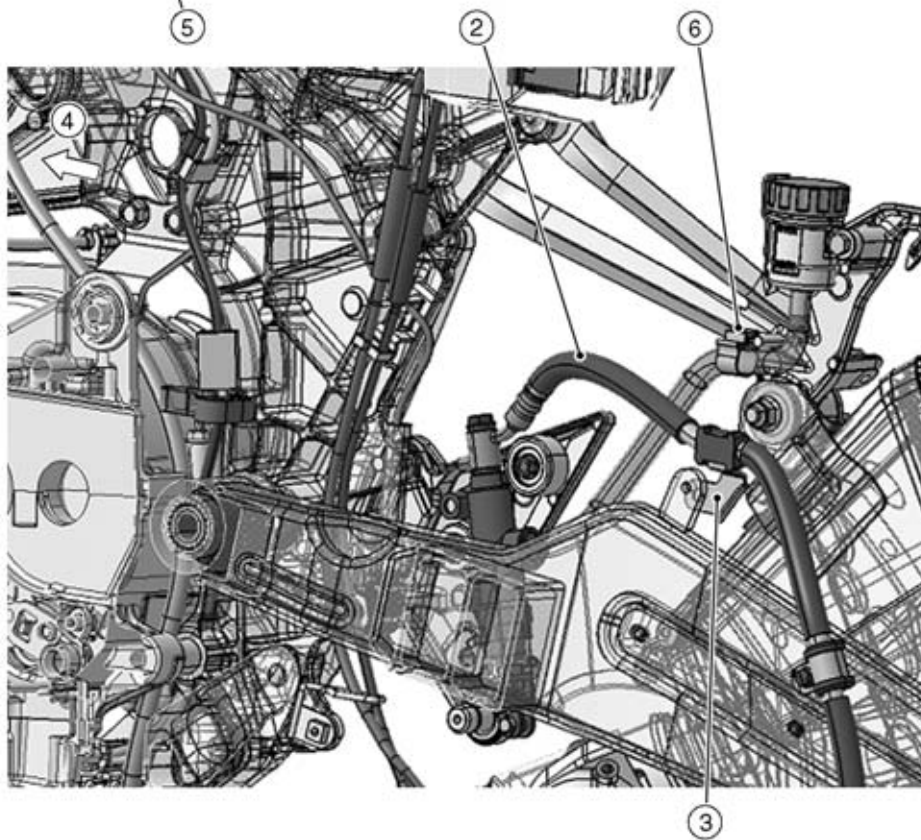
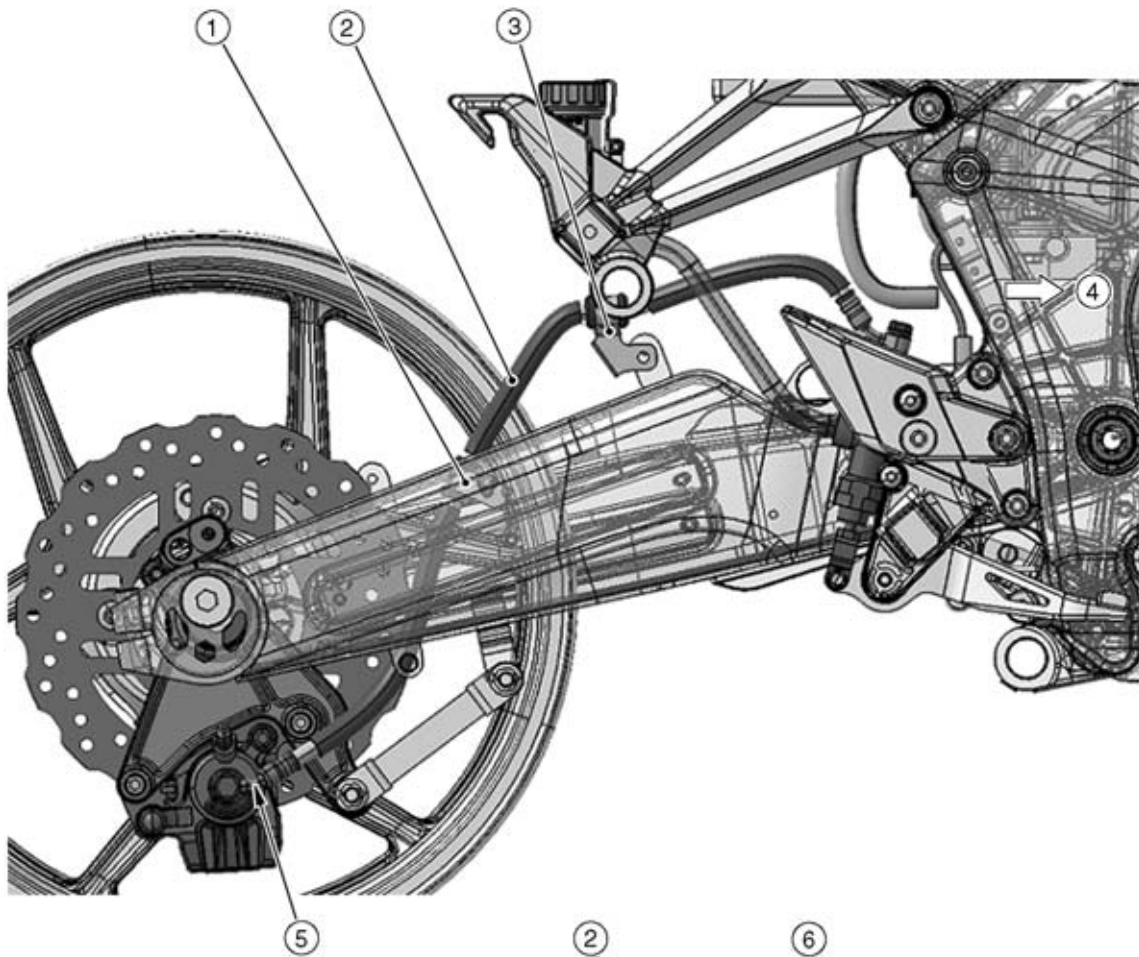

Cable, Wire, and Hose Routing

1. Clamp (for Brake Hose)
2. Brake Hose
3. Clamp (for Brake Hose)
4. Front
5. Fit the brake pipe to the stopper of the caliper as shown, and tighten the brake hose banjo bolt to the specified torque.
6. Clamp (for Brake Hose)

17-64 APPENDIX

Cable, Wire, and Hose Routing

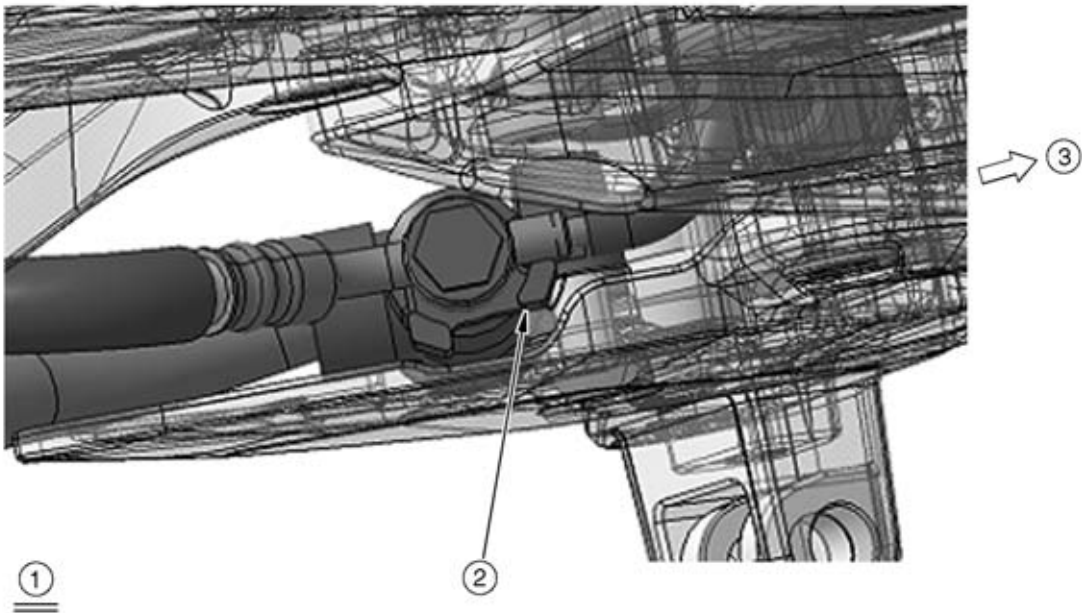
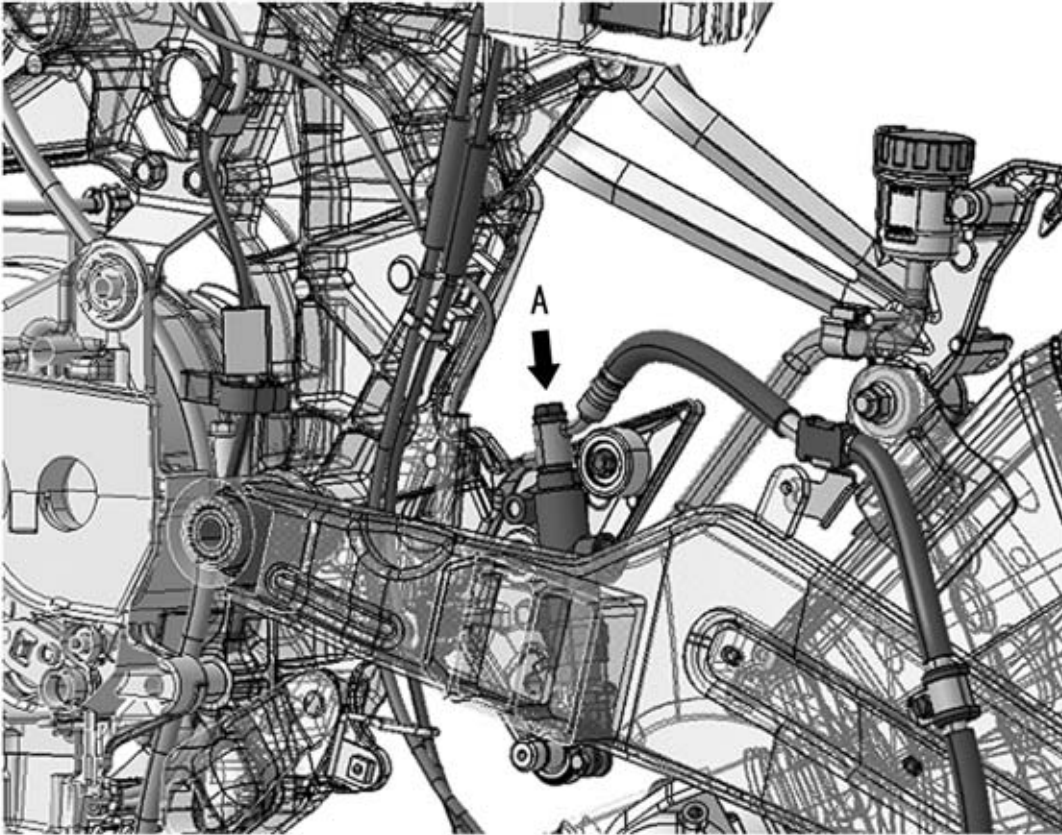

Cable, Wire, and Hose Routing

1. Viewed From A
2. Fit the projection of the brake hose end to the stopper as shown, and tighten the brake hose banjo bolt to the specified torque.
3. Front

17-66 APPENDIX

Cable, Wire, and Hose Routing

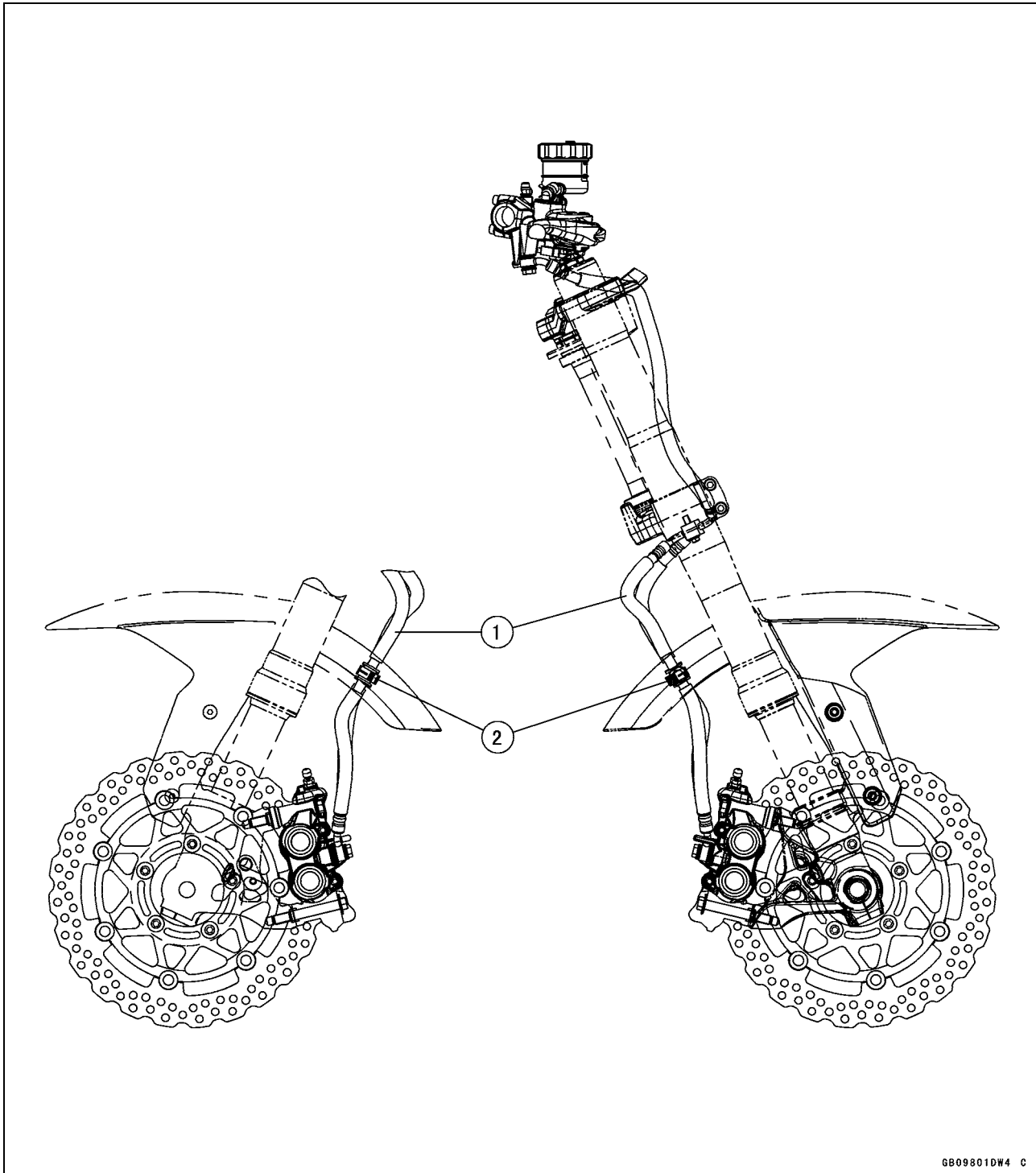

1. Brake Hoses

2. Clamps (Hold the grommet of the brake hose only. For ZX1000GB late model ~, face the lock portion of the clamp backward.)

Cable, Wire, and Hose Routing

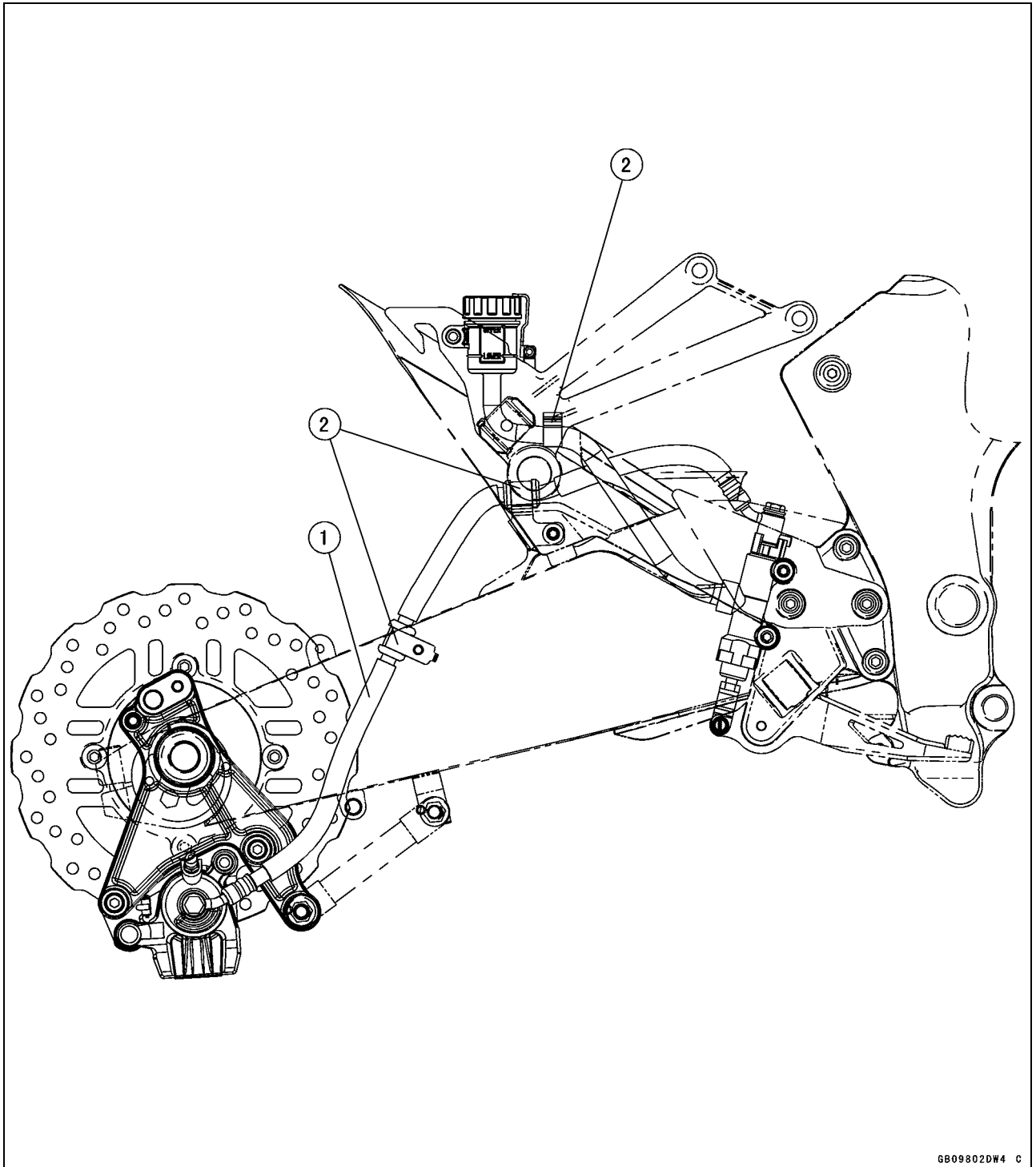

1. Brake Hose
2. Clamps

17-68 APPENDIX

Cable, Wire, and Hose Routing

CAL and SEA-B1 Models

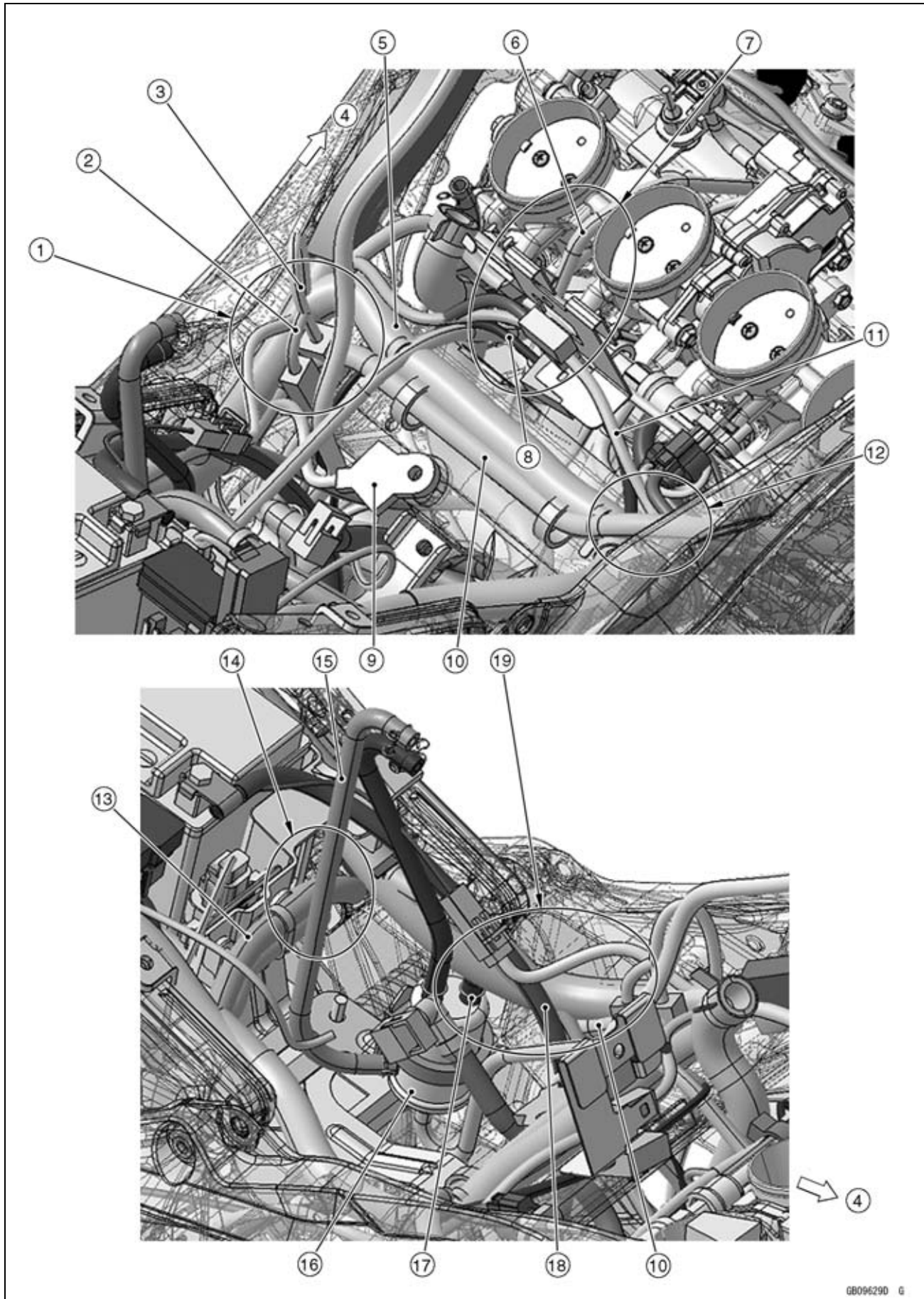

Cable, Wire, and Hose Routing

1. Run the purge hose to the inside of the sidestand switch lead and speed sensor lead, upside of the main harness and frame ground lead.
2. Sidestand Switch Lead
3. Speed Sensor Lead
4. Front
5. Main Harness
6. Vacuum Hose (between Separator and Throttle Body)
7. Run the vacuum hose to the under the delivery pipe of the throttle body assy. Crankshaft sensor lead and alternator lead. And run to the vacuum hose to upside of the main harness.
8. Alternator Lead
9. Frame Ground
10. Purge Hose (between Canister and Fitting for Air Switching Valve)
11. Crankshaft Sensor Lead
12. Run the purge hose to the upside of the other lead.
13. Regulator/Rectifier Harness
14. Run the return hose to the front side of the regulator/rectifier harness.
15. Return Hose (between Separator and Fuel Tank)
16. Separator
17. Breather Hose (between Separator and Canister)
18. Battery Negative (-) Lead
19. Run the Battery Negative (-) Lead to the upside of the breather hose and inside of the purge hose.

17-70 APPENDIX

Cable, Wire, and Hose Routing

CAL and SEA-B1 Models

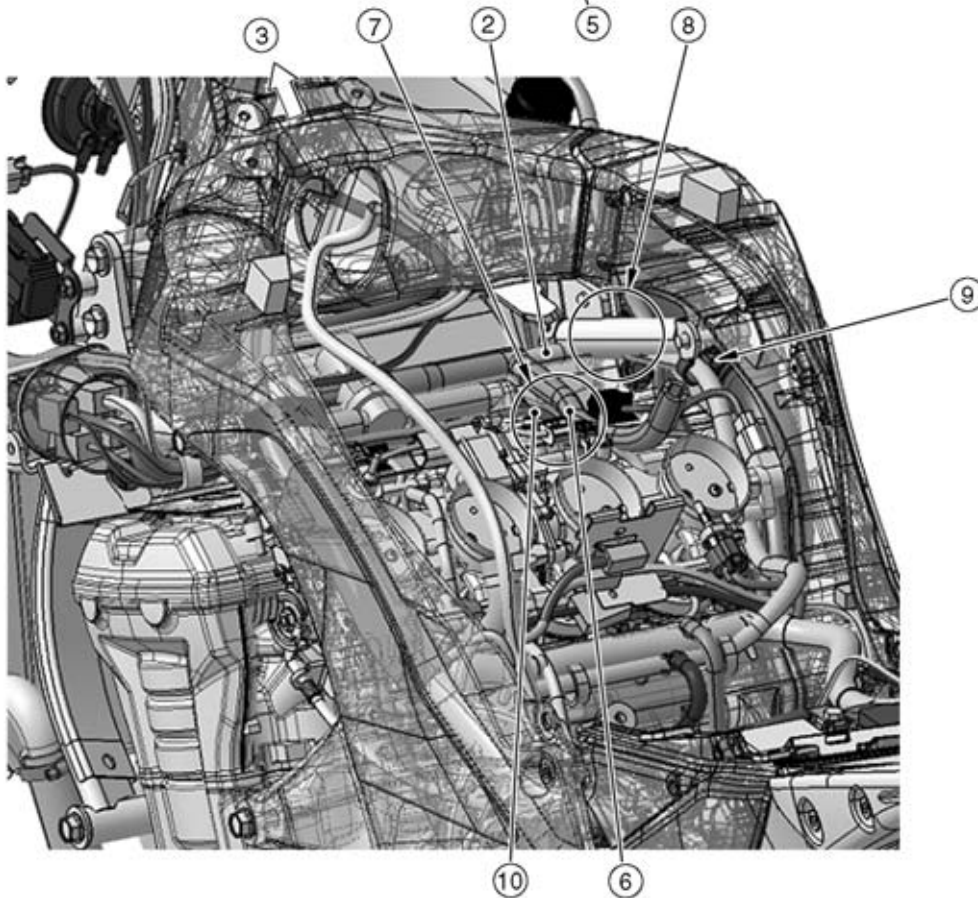
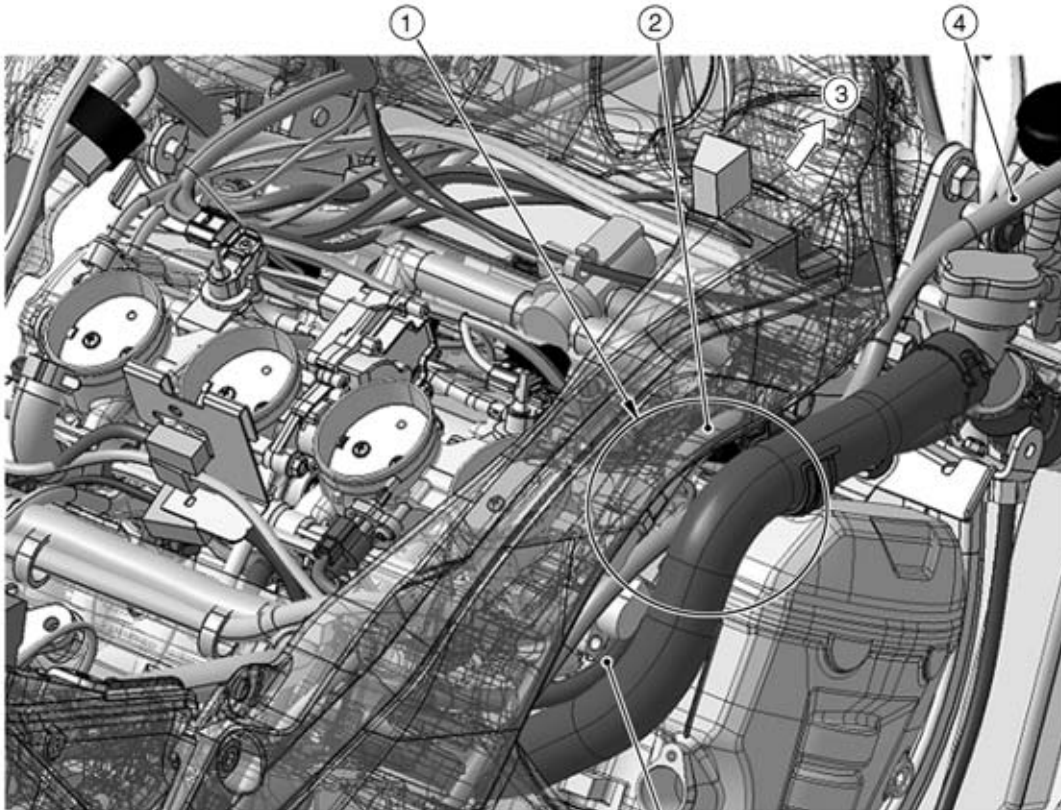

Cable, Wire, and Hose Routing

1. Run the water hose, reserve tank overflow hose, purge hose in order from the outside of frame.
2. Purge Hose (between Canister and Fitting for Air Switching Valve)
3. Front
4. Reserve Tank Overflow Hose
5. Water Hose
6. Air Switching Valve Hose (between Air Cleaner and Fitting for Air Switching Valve)
7. Run the air switching valve hose to the upside of the stick coil lead.
8. Run the purge hose under the engine mount bracket.
9. Hold the water hose, purge hose in order the outside of frame with clamp.
10. Stick Coil Lead

17-72 APPENDIX

Cable, Wire, and Hose Routing

CAL and SEA-B1 Models

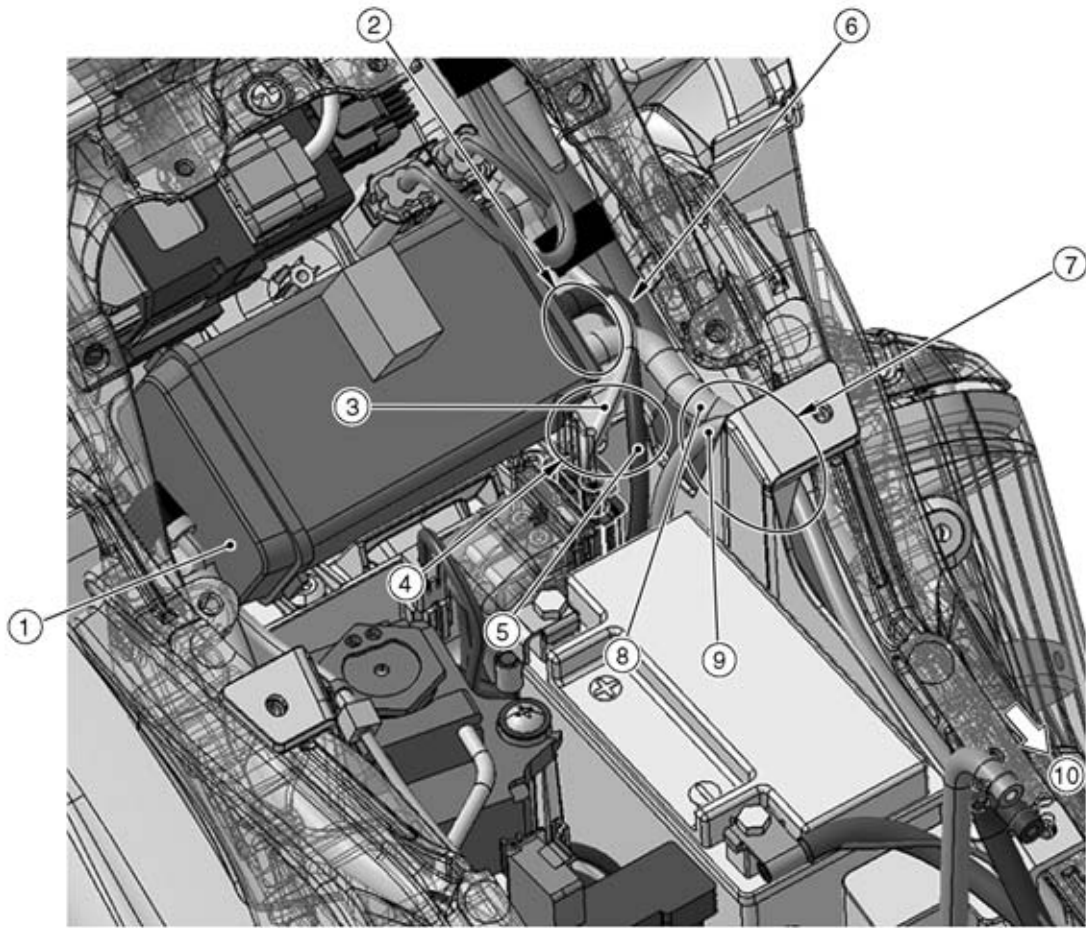

Cable, Wire, and Hose Routing

1. Canister
2. Install the canister hose clamps with its tabs facing upward.
3. Main Relay Lead
4. Run the breather hose and purge hose to the under the main relay lead.
5. Breather Hose (between Canister and Separator)
6. Run the breather hose under the purge hose.
7. Run the breather hose and purge to the upside of the main harness and to the outside of the starter motor cable.
8. Purge Hose (between Canister and Fitting for Air Switching Valve)
9. Starter Motor (+) Cable
10. Front

17-74 APPENDIX

Cable, Wire, and Hose Routing

CAL and SEA-B1 Models

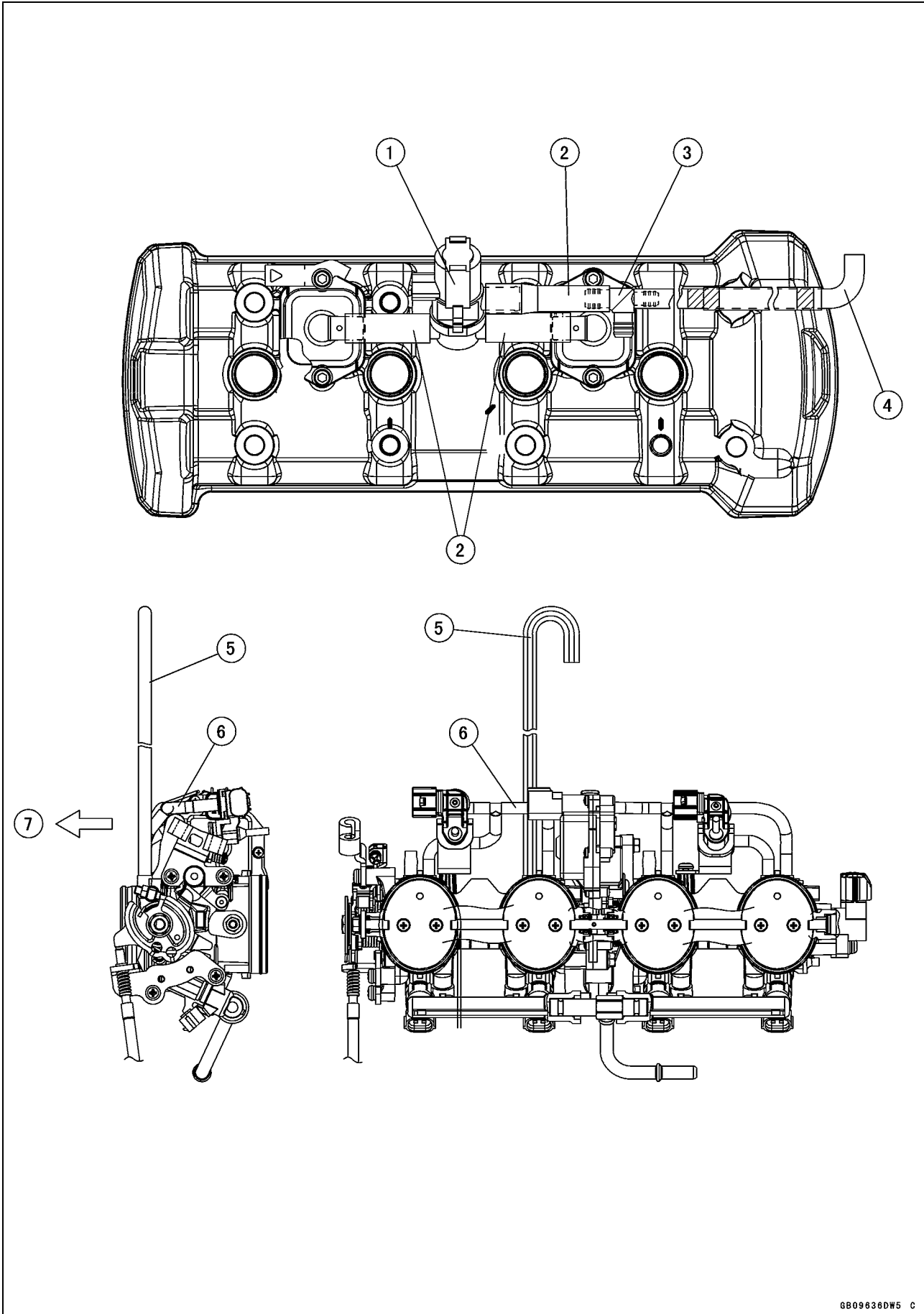

Cable, Wire, and Hose Routing

1. Air Switching Valve
2. Hoses
3. Fitting
4. Install the purge hose as shown in the direction.
5. Run the vacuum hose to the front side of the vacuum hose.
6. Vacuum Hose
7. Front

Troubleshooting Guide

NOTE

- Refer to the *Fuel System* chapter for most of DFI trouble shooting guide.
- This is not an exhaustive list, giving every possible cause for each problem listed. It is meant simply as a rough guide to assist the troubleshooting for some of the more common difficulties.

Engine Doesn't Start, Starting Difficulty:

Starter motor not rotating:

- Ignition and engine stop switch not ON
- Starter lockout switch or neutral switch trouble
- Starter motor trouble
- Battery voltage low
- Starter relay not contacting or operating
- Starter button not contacting
- Starter system wiring shorted or open
- Ignition switch trouble
- Engine stop switch trouble
- Main 30 A or ignition fuse blown

Starter motor rotating but engine doesn't turn over:

- Vehicle-down sensor (DFI) coming off
- Immobilizer system trouble (Equipped Models)
- Starter clutch trouble
- Starter idle gear trouble

Engine won't turn over:

- Valve seizure
- Valve lifter seizure
- Cylinder, piston seizure
- Crankshaft seizure
- Connecting rod small end seizure
- Connecting rod big end seizure
- Transmission gear or bearing seizure
- Camshaft seizure
- Starter idle gear seizure
- Balancer bearing seizure

No fuel flow:

- No fuel in tank
- Fuel pump trouble
- Fuel tank air vent obstructed
- Fuel filter clogged
- Fuel line clogged

No spark; spark weak:

- Vehicle-down sensor (DFI) coming off
- Ignition switch not ON
- Engine stop switch turned OFF
- Clutch lever not pulled in or gear not in neutral
- Battery voltage low
- Immobilizer system trouble (Equipped Models)

- Spark plug dirty, broken, or gap maladjusted
- Spark plug incorrect
- Stick coil shorted or not in good contact
- Stick coil trouble
- ECU trouble
- Neutral, starter lockout, or sidestand switch trouble
- Crankshaft sensor trouble
- Ignition switch or engine stop switch shorted
- Starter system wiring shorted or open
- Main 30 A or ignition fuse blown

Fuel/air mixture incorrect:

- Bypass screw and/or idle adjusting screw maladjusted
- Air passage clogged
- Air cleaner clogged, poorly sealed, or missing
- Leak from oil filler cap, crankcase breather hose or air cleaner drain hose.

Compression Low:

- Spark plug loose
- Cylinder head not sufficiently tightened down
- Cylinder, piston worn
- Piston ring bad (worn, weak, broken, or sticking)
- Piston ring/groove clearance excessive
- Cylinder head gasket damaged
- Cylinder head warped
- Valve spring broken or weak
- No valve clearance
- Valve not seating properly (valve bent, worn, or carbon accumulation on the seating surface)

Poor Running at Low Speed:

Spark weak:

- Battery voltage low
- Immobilizer system trouble (Equipped Models)
- Stick coil trouble
- Stick coil shorted or not in good contact
- Spark plug dirty, broken, or maladjusted
- Spark plug incorrect
- ECU trouble
- Crankshaft sensor trouble

Fuel/air mixture incorrect:

- Bypass screw maladjusted
- Air passage clogged
- Air bleed pipe bleed holes clogged
- Pilot passage clogged
- Air cleaner clogged, poorly sealed, or missing
- Fuel tank air vent obstructed
- Fuel pump trouble

Troubleshooting Guide

Throttle body assy holder loose

Air cleaner duct loose

Compression low:

Spark plug loose

Cylinder head not sufficiently tightened down

No valve clearance

Cylinder, piston worn

Piston ring bad (worn, weak, broken, or sticking)

Piston ring/groove clearance excessive

Cylinder head gasket damaged

Cylinder head warped

Valve spring broken or weak

Valve not seating properly (valve bent, worn, or carbon accumulation on the seating surface)

Camshaft cam worm

Run-on (dieseling):

Ignition switch trouble

Engine stop switch trouble

Fuel injector trouble

Loosen terminal of battery (-) cable or ECU ground lead

Carbon accumulating on valve seating surface

Engine overheating

Other:

ECU trouble

Throttle body assy not synchronizing

Engine oil viscosity too high

Drive train trouble

Brake dragging

Clutch slipping

Engine overheating

Air suction valve trouble

Air switching valve trouble

Poor Running or No Power at High Speed:

Firing incorrect:

Spark plug dirty, broken, or maladjusted

Spark plug incorrect

Stick coil shorted or not in good contact trouble

Stick coil trouble

ECU trouble

Fuel/air mixture incorrect:

Air cleaner clogged, poorly sealed, or missing

Air cleaner duct loose

Water or foreign matter in fuel

Throttle body assy holder loose

Fuel to injector insufficient

Fuel tank air vent obstructed

Fuel line clogged

Fuel pump trouble

Compression low:

Spark plug loose

Cylinder head not sufficiently tightened down

No valve clearance

Cylinder, piston worn

Piston ring bad (worn, weak, broken, or sticking)

Piston ring/groove clearance excessive

Cylinder head gasket damaged

Cylinder head warped

Valve spring broken or weak

Valve not seating properly (valve bent, worn, or carbon accumulation on the seating surface.)

Knocking:

Carbon built up in combustion chamber

Fuel poor quality or incorrect

Spark plug incorrect

ECU trouble

Miscellaneous:

Throttle valve won't fully open

Brake dragging

Clutch slipping

Engine overheating

Engine oil level too high

Engine oil viscosity too high

Drive train trouble

Camshaft cam worm

Air suction valve trouble

Air switching valve trouble

Catalytic converter melt down due to muffler overheating (KLEEN)

Overheating:

Firing incorrect:

Spark plug dirty, broken, or maladjusted

Spark plug incorrect

ECU trouble

Muffler overheating:

For KLEEN, do not run the engine even if with only one cylinder misfiring or poor running (Request the nearest service facility to correct it)

For KLEEN, do not push-start with a dead battery (Connect another full-charged battery with jumper cables, and start the engine using the electric starter)

For KLEEN, do not start the engine under misfire due to spark plug fouling or poor connection of the stick coil

For KLEEN, do not coast the motorcycle with the ignition switch off (Turn the ignition switch ON and run the engine)

ECU trouble

Fuel/air mixture incorrect:

Throttle body assy holder loose

17-78 APPENDIX

Troubleshooting Guide

- Air cleaner duct loose
- Air cleaner poorly sealed, or missing
- Air cleaner clogged

Compression high:

- Carbon built up in combustion chamber

Engine load faulty:

- Clutch slipping
- Engine oil level too high
- Engine oil viscosity too high
- Drive train trouble
- Brake dragging

Lubrication inadequate:

- Engine oil level too low
- Engine oil poor quality or incorrect

Oil cooler incorrect:

- Oil cooler clogged

Gauge incorrect:

- Water temperature gauge broken
- Water temperature sensor broken

Coolant incorrect:

- Coolant level too low
- Coolant deteriorated
- Wrong coolant mixed ratio

Cooling system component incorrect:

- Radiator fin damaged
- Radiator clogged
- Thermostat trouble
- Radiator cap trouble
- Radiator fan relay trouble
- Fan motor broken
- Fan blade damaged
- Water pump not turning
- Water pump impeller damaged

Over Cooling:

Gauge incorrect:

- Water temperature gauge broken
- Water temperature sensor broken

Cooling system component incorrect:

- Thermostat trouble

Clutch Operation Faulty:

Clutch slipping:

- Friction plate worn or warped
- Steel plate worn or warped
- Clutch spring broken or weak
- Clutch hub or housing unevenly worn
- No clutch lever play
- Clutch inner cable trouble
- Clutch release mechanism trouble

Clutch not disengaging properly:

- Clutch plate warped or too rough
- Clutch spring compression uneven
- Engine oil deteriorated
- Engine oil viscosity too high
- Engine oil level too high
- Clutch housing frozen on drive shaft

- Clutch hub nut loose
- Clutch hub spline damaged
- Clutch friction plate installed wrong
- Clutch lever play excessive
- Clutch release mechanism trouble

Gear Shifting Faulty:

Doesn't go into gear; shift pedal doesn't return:

- Clutch not disengaging
- Shift fork bent or seized
- Gear stuck on the shaft
- Gear positioning lever binding
- Shift return spring weak or broken
- Shift return spring pin loose
- Shift mechanism arm spring broken
- Shift mechanism arm broken
- Shift pawl broken

Jumps out of gear:

- Shift fork ear worn, bent
- Gear groove worn
- Gear dogs and/or dog holes worn
- Shift drum groove worn
- Gear positioning lever spring weak or broken
- Shift fork guide pin worn
- Drive shaft, output shaft, and/or gear splines worn

Overshifts:

- Gear positioning lever spring weak or broken
- Shift mechanism arm spring broken

Abnormal Engine Noise:

Knocking:

- ECU trouble
- Carbon built up in combustion chamber
- Fuel poor quality or incorrect
- Spark plug incorrect
- Overheating

Piston slap:

- Cylinder/piston clearance excessive
- Cylinder, piston worn
- Connecting rod bent
- Piston pin, piston pin hole worn

Valve noise:

- Valve clearance incorrect
- Valve spring broken or weak
- Camshaft bearing worn
- Valve lifter worn

Other noise:

- Connecting rod small end clearance excessive
- Connecting rod big end clearance excessive
- Piston ring/groove clearance excessive
- Piston ring worn, broken, or stuck

Troubleshooting Guide

Piston ring groove worn
 Piston seizure, damage
 Cylinder head gasket leaking
 Exhaust pipe leaking at cylinder head connection
 Crankshaft runout excessive
 Engine mount loose
 Crankshaft bearing worn
 Primary gear worn or chipped
 Camshaft chain tensioner trouble
 Camshaft chain, sprocket, guide worn
 Air suction valve damaged
 Air switching valve damaged
 Alternator rotor loose
 Catalytic converter melt down due to muffler overheating (KLEEN)
 Exhaust butterfly valve cable loose
 Balancer gear worn or chipped
 Balancer shaft position maladjusted
 Balancer bearing worn
 Balancer rubber damper damaged

Abnormal Drive Train Noise:

Clutch noise:

Clutch damper weak or damaged
 Clutch housing/friction plate clearance excessive
 Clutch housing gear worn
 Wrong installation of outside friction plate

Transmission noise:

Bearings worn
 Transmission gear worn or chipped
 Metal chips jammed in gear teeth
 Engine oil insufficient

Drive line noise:

Drive chain adjusted improperly
 Drive chain worn
 Rear and/or engine sprocket worn
 Chain lubrication insufficient
 Rear wheel misaligned

Abnormal Frame Noise:

Front fork noise:

Oil insufficient or too thin
 Spring weak or broken

Rear shock absorber noise:

Shock absorber damaged

Disc brake noise:

Pad installed incorrectly
 Pad surface glazed
 Disc warped
 Caliper trouble

Other noise:

Bracket, nut, bolt, etc. not properly mounted or tightened

Oil Pressure Warning Indicator Light (LED) Goes On:

Engine oil pump damaged
 Engine oil screen clogged
 Engine oil filter clogged
 Engine oil level too low
 Engine oil viscosity too low
 Camshaft bearing worn
 Crankshaft bearing worn
 Oil pressure switch damaged
 Wiring faulty
 Relief valve stuck open
 O-ring at the oil passage in the crankcase damaged

Exhaust Smokes Excessively:

White smoke:

Piston oil ring worn
 Cylinder worn
 Valve oil seal damaged
 Valve guide worn
 Engine oil level too high

Black smoke:

Air cleaner clogged

Brown smoke:

Air cleaner duct loose
 Air cleaner poorly sealed or missing

Handling and/or Stability Unsatisfactory:

Handlebar hard to turn:

Cable routing incorrect
 Hose routing incorrect
 Wiring routing incorrect
 Steering stem nut too tight
 Steering stem bearing damaged
 Steering stem bearing lubrication inadequate
 Steering stem bent
 Tire air pressure too low

Handlebar shakes or excessively vibrates:

Tire worn
 Swingarm pivot bearing worn
 Rim warped, or not balanced
 Wheel bearing worn
 Handlebar holder bolt loose
 Steering stem nut loose
 Front, rear axle runout excessive
 Engine mounting bolt loose

Handlebar pulls to one side:

Frame bent
 Wheel misalignment
 Swingarm bent or twisted
 Swingarm pivot shaft runout excessive
 Steering maladjusted
 Front fork bent
 Right and left front fork oil level uneven

17-80 APPENDIX

Troubleshooting Guide

Shock absorption unsatisfactory:

(Too hard)
Front fork oil excessive
Front fork oil viscosity too high
Rear shock absorber adjustment too hard
Tire air pressure too high
Front fork bent
(Too soft)
Tire air pressure too low
Front fork oil insufficient and/or leaking
Front fork oil viscosity too low
Rear shock adjustment too soft
Front fork, rear shock absorber spring weak
Rear shock absorber oil leaking

Brake Doesn't Hold:

Air in the brake line
Pad or disc worn
Brake fluid leakage
Disc warped
Contaminated pad

Brake fluid deteriorated
Primary or secondary cup damaged in master cylinder
Master cylinder scratched inside

Battery Trouble:

Battery discharged:

Charge insufficient
Battery faulty (too low terminal voltage)
Battery cable making poor contact
Load excessive (e.g., bulb of excessive wattage)
Ignition switch trouble
Alternator trouble
Wiring faulty
Regulator/rectifier trouble

Battery overcharged:

Alternator trouble
Regulator/rectifier trouble
Battery faulty

MODEL APPLICATION

Year	Model	Beginning Frame No.
2011	ZX1000GB	JKAZXCG1□BA000001 JKAZXT00GGA000001
2011	ZX1000HB	JKAZXCH1□BA000001 JKAZXT00GHA000001
2012	ZX1000GC	JKAZXCG1□CA013001 JKAZXT00GGA013001
2012	ZX1000HC	JKAZXCH1□CA003001 JKAZXT00GHA013001

□:This digit in the frame number changes from one machine to another.



KAWASAKI HEAVY INDUSTRIES, LTD.
Motorcycle & Engine Company

Part No.99924-1442-02

Printed in Japan